



**INTEGRATED CIRCUITS, SILICON MONOLITHIC, PULSE  
WIDTH MODULATOR**

**BASED ON TYPE ST1843**

**Detail Specification No. 9108/020**

Issue 2	June 2016
---------	-----------



### **LEGAL DISCLAIMER AND COPYRIGHT**

European Space Agency, Copyright © 2016. All rights reserved.

The European Space Agency disclaims any liability or responsibility, to any person or entity, with respect to any loss or damage caused, or alleged to be caused, directly or indirectly by the use and application of this ESCC publication.

This publication, without the prior permission of the European Space Agency and provided that it is not used for a commercial purpose, may be:

- copied in whole, in any medium, without alteration or modification.
- copied in part, in any medium, provided that the ESCC document identification, comprising the ESCC symbol, document number and document issue, is removed.

**DOCUMENTATION CHANGE NOTICE**

(Refer to <https://escies.org> for ESCC DCR content)

DCR No.	CHANGE DESCRIPTION
997, 998, 1001	Specification updated to incorporate changes per DCRs.

**TABLE OF CONTENTS**

1	GENERAL	5
1.1	SCOPE	5
1.2	APPLICABLE DOCUMENTS	5
1.3	TERMS, DEFINITIONS, ABBREVIATIONS, SYMBOLS AND UNITS	5
1.4	THE ESCC COMPONENT NUMBER AND COMPONENT TYPE VARIANTS	5
1.4.1	The ESCC Component Number	5
1.4.2	Component Type Variants	5
1.5	MAXIMUM RATINGS	6
1.6	HANDLING PRECAUTIONS	6
1.7	PHYSICAL DIMENSIONS AND TERMINAL IDENTIFICATION	7
1.8	FUNCTIONAL DIAGRAM	8
1.9	PIN ASSIGNMENT	8
2	REQUIREMENTS	9
2.1	GENERAL	9
2.1.1	Deviations from the Generic Specification	9
2.2	MARKING	9
2.3	ELECTRICAL MEASUREMENTS AT ROOM, HIGH AND LOW TEMPERATURES	9
2.3.1	Room Temperature Electrical Measurements	9
2.3.2	High and Low Temperatures Electrical Measurements	12
2.3.3	Notes to Electrical Measurement Tables	15
2.4	PARAMETER DRIFT VALUES	15
2.5	INTERMEDIATE AND END-POINT ELECTRICAL MEASUREMENTS	15
2.6	HIGH TEMPERATURE REVERSE BIAS BURN-IN CONDITIONS	16
2.7	POWER BURN-IN CONDITIONS	16
2.8	OPERATING LIFE CONDITIONS	17
2.9	TOTAL DOSE RADIATION TESTING	18
2.9.1	Bias Conditions and Total Dose Level for Total Dose Radiation Testing	18
2.9.2	Electrical Measurements for Total Dose Radiation Testing	18
	APPENDIX 'A'	21

## 1 GENERAL

### 1.1 SCOPE

This specification details the ratings, physical and electrical characteristics and test and inspection data for the component type variants and/or the range of components specified below. It supplements the requirements of, and shall be read in conjunction with, the ESCC Generic Specification listed under Applicable Documents.

### 1.2 APPLICABLE DOCUMENTS

The following documents form part of this specification and shall be read in conjunction with it:

- (a) ESCC Generic Specification No. 9000.
- (b) MIL-STD-883, Test Methods and Procedures for Microelectronics.

### 1.3 TERMS, DEFINITIONS, ABBREVIATIONS, SYMBOLS AND UNITS

For the purpose of this specification, the terms, definitions, abbreviations, symbols and units specified in ESCC Basic Specification No. 21300 shall apply.

### 1.4 THE ESCC COMPONENT NUMBER AND COMPONENT TYPE VARIANTS

#### 1.4.1 The ESCC Component Number

The ESCC Component Number shall be constituted as follows:

Example: 910802001F

- Detail Specification Reference: 9108020
- Component Type Variant Number: 01 (as required)
- Total Dose Radiation Level Letter: F (as required)

#### 1.4.2 Component Type Variants

The component type variants applicable to this specification are as follows:

Variant Number	Based on Type	Case	Terminal Material and Finish	Weight max g	Total Dose Radiation Level Letter
01	ST1843	FP	G2	0.45	F [50krad(Si)]
02	ST1843	FP	G4	0.45	F [50krad(Si)]

The terminal material and finish shall be in accordance with the requirements of ESCC Basic Specification No. 23500.

Total dose radiation level letters are defined in ESCC Basic Specification No. 22900. If an alternative radiation test level is specified in the Purchase Order the letter shall be changed accordingly.

### 1.5 MAXIMUM RATINGS

The maximum ratings shall not be exceeded at any time during use or storage.

Maximum ratings shall only be exceeded during testing to the extent specified in this specification and when stipulated in Test Methods and Procedures of the ESCC Generic Specification.

Characteristics	Symbols	Maximum Ratings	Units	Remarks
Supply Voltage (low impedance source)	$V_i$	30	V	Note 1
Supply Current	$I_i$	30	mA	Notes 1, 2
Output Current	$I_o$	$\pm 1$	A	Note 1
Output Energy (capacitive load)	$E_o$	5	$\mu\text{J}$	
Analogue Inputs	-	-0.3 to 5.5	V	Pins 2, 3
Error Amplifier Output Sink Current	$I_{o-SINK}$	10	mA	Note 1
Operating Temperature Range	$T_{op}$	-55 to +125	$^{\circ}\text{C}$	$T_{amb}$
Storage Temperature Range	$T_{stg}$	-65 to +150	$^{\circ}\text{C}$	
Junction Temperature	$T_j$	+150	$^{\circ}\text{C}$	
Soldering Temperature	$T_{sol}$	+265	$^{\circ}\text{C}$	Note 3

#### **NOTES:**

1. All voltages are with respect to Ground, all currents are positive into the specified terminal.
2. Supply voltage is self-limited by Zener clamp.
3. Duration 10 seconds maximum at a distance of not less than 1.5mm from the device body and the same terminal shall not be resoldered until 3 minutes have elapsed.

### 1.6 HANDLING PRECAUTIONS

These devices are susceptible to damage by electrostatic discharge. Therefore, suitable precautions shall be employed for protection during all phases of manufacture, testing, packaging, shipment and any handling.

These components are categorised as Class 2 per ESCC Basic Specification No. 23800 with a Minimum Critical Path Failure Voltage of 2000 Volts.

1.7 PHYSICAL DIMENSIONS AND TERMINAL IDENTIFICATION  
Flat Package (FP) - 8 Pin

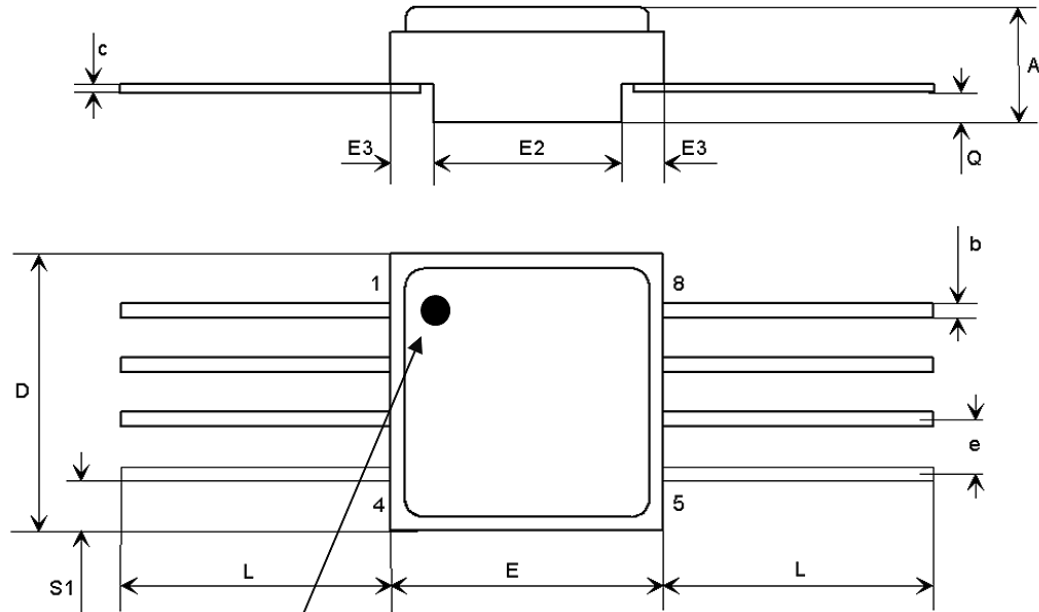

Note 1

Symbols	Dimensions mm		Notes
	Min	Max	
A	2.24	2.64	
b	0.38	0.48	2
c	0.1	0.16	2
D	6.35	6.61	
E	6.35	6.61	
E2	4.32	4.58	
E3	0.88	1.14	
e	1.27 BSC		3
L	6.51	7.38	2
Q	0.66	0.92	
S1	0.92	1.32	4

**NOTES:**

1. Terminal identification shall be by means of a notch or a dot located adjacent to Pin 1.
2. Applies to all pins.
3. 6 places.
4. 4 places.

1.8 FUNCTIONAL DIAGRAM

Note: For the ST1843 the toggle flip-flop is unused.

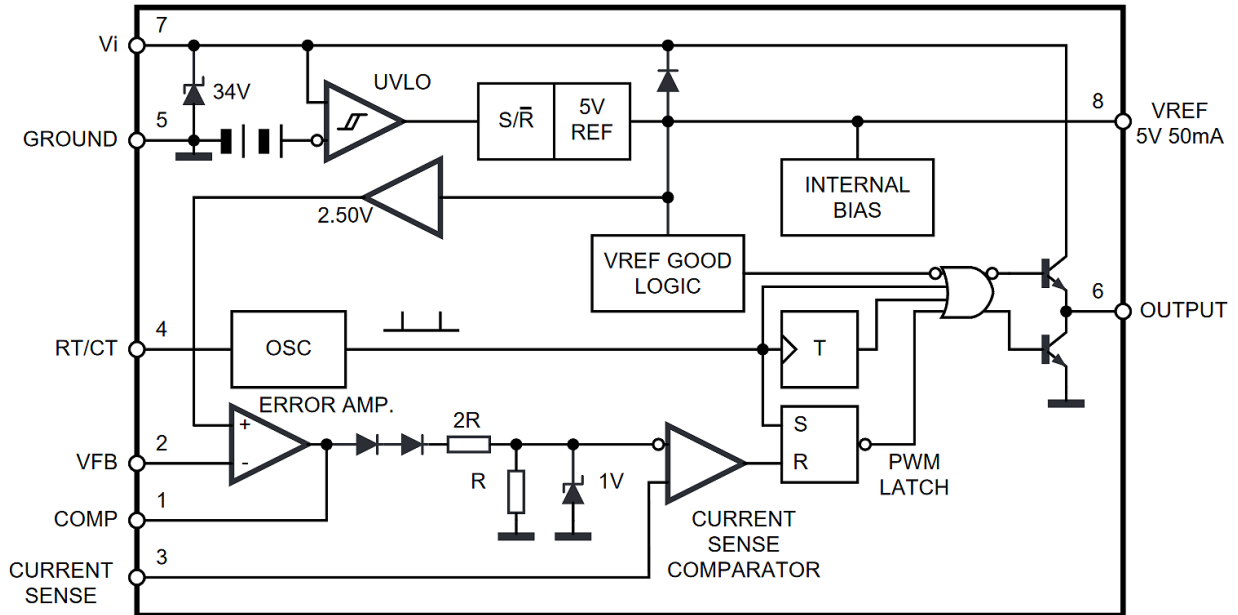

1.9 PIN ASSIGNMENT

Pin	Name	Description
1	COMP	This pin is the Error Amplifier output and is made available for loop compensation.
2	V <sub>FB</sub>	This is the inverting input of the Error Amplifier. It is normally connected to the switching power supply output through a resistor divider.
3	I <sub>SENSE</sub>	A voltage proportional to inductor current is connected to this input. The PWM uses this information to terminate the output switch conduction.
4	R <sub>T</sub> /C <sub>T</sub>	The oscillator frequency and maximum Output duty cycle are programmed by connecting resistor R <sub>T</sub> to V <sub>ref</sub> and capacitor C <sub>T</sub> to ground. Operation to 500kHz is possible.
5	GROUND	This pin is the combined control circuitry and power ground.
6	OUTPUT	This output directly drives the gate of a power MOSFET. Peak currents up to 1A are sourced and sunk by this pin.
7	V <sub>i</sub>	This pin is the positive supply of the control IC.
8	V <sub>ref</sub>	This is the reference output. It provides charging current for capacitor C <sub>T</sub> through resistor R <sub>T</sub> .



**2 REQUIREMENTS**

**2.1 GENERAL**

The complete requirements for procurement of the components specified herein are as stated in this specification and the ESCC Generic Specification. Permitted deviations from the Generic Specification, applicable to this specification only, are listed below.

Permitted deviations from the Generic Specification and this Detail Specification, formally agreed with specific Manufacturers on the basis that the alternative requirements are equivalent to the ESCC requirement and do not affect the component's reliability, are listed in the appendices attached to this specification.

**2.1.1 Deviations from the Generic Specification**

None.

**2.2 MARKING**

The marking shall be in accordance with the requirements of ESCC Basic Specification No. 21700 and as follows.

The information to be marked on the component shall be:

- (a) Terminal identification.
- (b) The ESCC qualified components symbol (for ESCC qualified components only).
- (c) The ESCC Component Number.
- (d) Traceability information.

**2.3 ELECTRICAL MEASUREMENTS AT ROOM, HIGH AND LOW TEMPERATURES**

Electrical measurements shall be performed at room, high and low temperatures. Consolidated Notes are given after the tables.

**2.3.1 Room Temperature Electrical Measurements**

The measurements shall be performed at  $T_{amb} = +22 \pm 3^{\circ}C$ .

Characteristics	Symbols	MIL-STD-883 Test Method	Test Conditions	Limits		Units
				Min	Max	
<b>REFERENCE SECTION</b>						
Output Voltage	$V_{REF}$	-	$V_i = 15V$ $R_T = 10k\Omega, C_T = 3.3nF$ $I_o = 1mA$	4.95	5.05	V
Line regulation	$\Delta V_{REF\_LINE}$	-	$12V \leq V_i \leq 25V$ $R_T = 10k\Omega, C_T = 3.3nF$	-	20	mV
Load Regulation	$\Delta V_{REF\_LOAD}$	-	$V_i = 15V$ $R_T = 10k\Omega, C_T = 3.3nF$ $1mA \leq I_o \leq 20mA$	-	19	mV
Output Short Circuit Current	$I_{SC}$	3011	$V_i = 15V$ $R_T = 10k\Omega, C_T = 3.3nF$	-180	-30	mA

Characteristics	Symbols	MIL-STD-883 Test Method	Test Conditions	Limits		Units
				Min	Max	
<b>OSCILLATOR SECTION</b>						
Frequency	$f_{OSC}$	-	$V_i = 15V$ $R_T = 10k\Omega, C_T = 3.3nF$	49	55	kHz
Frequency Change with Voltage	$\Delta f_{OSC}/\Delta V$	-	$12V \leq V_i \leq 25V$ $R_T = 10k\Omega, C_T = 3.3nF$	-1	1	%
Discharge Current	$I_{DISCHG}$	-	$V_i = 15V$ $R_T = 10k\Omega, C_T = 3.3nF$ $V_{OSC} = 2V$	8.1	8.8	mA
<b>ERROR AMP SECTION</b>						
Input Voltage	$V_2$	-	$V_i = 15V$ $R_T = 10k\Omega, C_T = 3.3nF$ $V_{PIN1} = 2.5V$	2.45	2.55	V
Input Bias Current	$I_b$	4001	$V_i = 15V$ $R_T = 10k\Omega, C_T = 3.3nF$ $V_{FB} = 5V$	-1	1	$\mu A$
Open Loop Voltage Gain	$A_{VOL}$	-	$V_i = 15V$ $R_T = 10k\Omega, C_T = 3.3nF$ $2V \leq V_O \leq 4V$	65	-	dB
Power Supply Rejection Ratio	PSRR	4003	$12V \leq V_i \leq 25V$ $R_T = 10k\Omega, C_T = 3.3nF$	67	-	dB
Output Sink Current	$I_{O\_SINK}$	-	$V_i = 15V$ $R_T = 10k\Omega, C_T = 3.3nF$ $V_{PIN2} = 2.7V$ $V_{PIN1} = 1.1V$	6	-	mA
Output Source Current	$I_{O\_SOURCE}$	-	$V_i = 15V$ $R_T = 10k\Omega, C_T = 3.3nF$ $V_{PIN2} = 2.3V$ $V_{PIN1} = 5V$	-	-1	mA
$V_{OUT}$ High	$V_{OH}$	-	$V_i = 15V$ $R_T = 10k\Omega, C_T = 3.3nF$ $V_{PIN2} = 2.3V$ $R_L = 15k\Omega$ to GROUND	6.2	-	V
$V_{OUT}$ Low	$V_{OL}$	-	$V_i = 15V$ $R_T = 10k\Omega, C_T = 3.3nF$ $V_{PIN2} = 2.3V$ $R_L = 15k\Omega$ to $V_{ref}$	-	950	mV

Characteristics	Symbols	MIL-STD-883 Test Method	Test Conditions	Limits		Units
				Min	Max	
<b>CURRENT SENSE SECTION</b>						
Gain	$G_V$	4004	$V_i = 15V$ $R_T = 10k\Omega$ , $C_T = 3.3nF$ Notes 1, 2	2.85	3.15	V/V
Maximum Input Signal	$V_3$	-	$V_i = 15V$ $R_T = 10k\Omega$ , $C_T = 3.3nF$ $V_{PIN1} = 2.3V$ Note 1	0.9	1.05	V
Supply Voltage Rejection	SVR	-	$12V \leq V_i \leq 25V$ $R_T = 10k\Omega$ , $C_T = 3.3nF$ Note 1	74	-	dB
Input Bias Current	$I_b$	4001	$V_i = 15V$ $R_T = 10k\Omega$ , $C_T = 3.3nF$	-10	10	$\mu A$
Delay to output	$d_o$	3003	$V_i = 15V$ $R_T = 10k\Omega$ , $C_T = 3.3nF$	-	300	ns
<b>OUTPUT SECTION</b>						
Output Low Level	$V_{OL1}$	3007	$V_i = 15V$ $R_T = 10k\Omega$ , $C_T = 3.3nF$ $I_{SINK} = 20mA$	-	260	mV
Output Low Level	$V_{OL2}$	3007	$V_i = 15V$ $R_T = 10k\Omega$ , $C_T = 3.3nF$ $I_{SINK} = 200mA$	-	2.2	V
Output High level	$V_{OH1}$	3006	$V_i = 15V$ $R_T = 10k\Omega$ , $C_T = 3.3nF$ $I_{SOURCE} = 20mA$	13	-	V
Output High Level	$V_{OH2}$	3006	$V_i = 15V$ $R_T = 10k\Omega$ , $C_T = 3.3nF$ $I_{SOURCE} = 200mA$	12	-	V
UVLO Saturation	$V_{OLS}$	-	$V_i = 6V$ $R_T = 10k\Omega$ , $C_T = 3.3nF$ $I_{SINK} = 1mA$	-	1.1	V
Rise Time	$t_r$	3004	$V_i = 15V$ $R_T = 10k\Omega$ , $C_T = 3.3nF$ $C_L = 1nF$	-	150	ns
Fall Time	$t_f$	3004	$V_i = 15V$ $R_T = 10k\Omega$ , $C_T = 3.3nF$ $C_L = 1nF$	-	150	ns

Characteristics	Symbols	MIL-STD-883 Test Method	Test Conditions	Limits		Units
				Min	Max	
<b>UNDER-VOLTAGE LOCKOUT SECTION</b>						
Start Threshold	$V_{TH}$	-	$V_i = 15V$ $R_T = 10k\Omega, C_T = 3.3nF$	7.8	9	V
Min Operating Voltage after Turn-on	$V_{MIN}$	-	$V_i = 15V$ $R_T = 10k\Omega, C_T = 3.3nF$	7	8.2	V
Max Duty Cycle	$DC_{MAX}$	-	$V_i = 15V$ $R_T = 10k\Omega, C_T = 3.3nF$	94	100	%
Min Duty Cycle	$DC_{MIN}$	-	$V_i = 15V$ $R_T = 10k\Omega, C_T = 3.3nF$	-	0	%
<b>TOTAL STAND-BY CURRENT</b>						
Start-up current	$I_{ST}$	-	$V_i = 6.5V$ $R_T = 10k\Omega, C_T = 3.3nF$	-	500	$\mu A$
Operating Supply Current	$I_i$	3005	$V_i = 15V$ $R_T = 10k\Omega, C_T = 3.3nF$ $V_{PIN2} = V_{PIN3} = 0V$	-	17	mA
Zener Voltage	$V_{iz}$	-	$V_i = 15V$ $R_T = 10k\Omega, C_T = 3.3nF$ $I_i = 25mA$	30	-	V

### 2.3.2 High and Low Temperatures Electrical Measurements

The measurements shall be performed at  $T_{amb} = +125 (+0 -5)^{\circ}C$  and  $T_{amb} = -55 (+5 -0)^{\circ}C$ .

Characteristics	Symbols	MIL-STD-883 Test Method	Test Conditions	Limits		Units
				Min	Max	
<b>REFERENCE SECTION</b>						
Output Voltage	$V_{REF}$	-	$V_i = 15V$ $R_T = 10k\Omega, C_T = 3.3nF$ $I_o = 1mA$	4.9	5.05	V
Line regulation	$\Delta V_{REF\_LINE}$	-	$12V \leq V_i \leq 25V$ $R_T = 10k\Omega, C_T = 3.3nF$	-	50	mV
Load Regulation	$\Delta V_{REF\_LOAD}$	-	$V_i = 15V$ $R_T = 10k\Omega, C_T = 3.3nF$ $1mA \leq I_o \leq 20mA$	-	25	mV
Output Short Circuit Current	$I_{SC}$	3011	$V_i = 15V$ $R_T = 10k\Omega, C_T = 3.3nF$	-180	-30	mA
<b>OSCILLATOR SECTION</b>						
Frequency	$f_{OSC}$	-	$V_i = 15V$ $R_T = 10k\Omega, C_T = 3.3nF$	49	56	kHz
Frequency Change with Voltage	$\Delta f_{OSC}/\Delta V$	-	$12V \leq V_i \leq 25V$ $R_T = 10k\Omega, C_T = 3.3nF$	-5	5	%
Discharge Current	$I_{DISCHG}$	-	$V_i = 15V$ $R_T = 10k\Omega, C_T = 3.3nF$ $V_{OSC} = 2V$	7.2	8.8	mA

Characteristics	Symbols	MIL-STD-883 Test Method	Test Conditions	Limits		Units
				Min	Max	
<b>ERROR AMP SECTION</b>						
Input Voltage	$V_2$	-	$V_i = 15V$ $R_T = 10k\Omega, C_T = 3.3nF$ $V_{PIN1} = 2.5V$	2.4	2.55	V
Input Bias Current	$I_b$	4001	$V_i = 15V$ $R_T = 10k\Omega, C_T = 3.3nF$ $V_{FB} = 5V$	-1	1	$\mu A$
Open Loop Voltage Gain	$A_{VOL}$	-	$V_i = 15V$ $R_T = 10k\Omega, C_T = 3.3nF$ $2V \leq V_O \leq 4V$	65	-	dB
Power Supply Rejection Ratio	PSRR	4003	$12V \leq V_i \leq 25V$ $R_T = 10k\Omega, C_T = 3.3nF$	50	-	dB
Output Sink Current	$I_{O\_SINK}$	-	$V_i = 15V$ $R_T = 10k\Omega, C_T = 3.3nF$ $V_{PIN2} = 2.7V$ $V_{PIN1} = 1.1V$	2	-	mA
Output Source Current	$I_{O\_SOURCE}$	-	$V_i = 15V$ $R_T = 10k\Omega, C_T = 3.3nF$ $V_{PIN2} = 2.3V$ $V_{PIN1} = 5V$	-	-500	$\mu A$
$V_{OUT}$ High	$V_{OH}$	-	$V_i = 15V$ $R_T = 10k\Omega, C_T = 3.3nF$ $V_{PIN2} = 2.3V$ $R_L = 15k\Omega$ to GROUND	5	-	V
$V_{OUT}$ Low	$V_{OL}$	-	$V_i = 15V$ $R_T = 10k\Omega, C_T = 3.3nF$ $V_{PIN2} = 2.3V$ $R_L = 15k\Omega$ to $V_{ref}$	-	1.1	V
<b>CURRENT SENSE SECTION</b>						
Gain	$G_V$	4004	$V_i = 15V$ $R_T = 10k\Omega, C_T = 3.3nF$ Notes 1, 2	2.85	3.15	V/V
Maximum Input Signal	$V_3$	-	$V_i = 15V$ $R_T = 10k\Omega, C_T = 3.3nF$ $V_{PIN1} = 2.3V$ Note 1	0.9	1.1	V
Supply Voltage Rejection	SVR	-	$12V \leq V_i \leq 25V$ $R_T = 10k\Omega, C_T = 3.3nF$ Note 1	50	-	dB
Input Bias Current	$I_b$	4001	$V_i = 15V$ $R_T = 10k\Omega, C_T = 3.3nF$	-10	10	$\mu A$
Delay to output	$d_o$	3003	$V_i = 15V$ $R_T = 10k\Omega, C_T = 3.3nF$	-	300	ns

Characteristics	Symbols	MIL-STD-883 Test Method	Test Conditions	Limits		Units
				Min	Max	
<b>OUTPUT SECTION</b>						
Output Low Level	$V_{OL1}$	3007	$V_i = 15V$ $R_T = 10k\Omega$ , $C_T = 3.3nF$ $I_{SINK} = 20mA$	-	400	mV
Output Low Level	$V_{OL2}$	3007	$V_i = 15V$ $R_T = 10k\Omega$ , $C_T = 3.3nF$ $I_{SINK} = 200mA$	-	2.2	V
Output High level	$V_{OH1}$	3006	$V_i = 15V$ $R_T = 10k\Omega$ , $C_T = 3.3nF$ $I_{SOURCE} = 20mA$	13	-	V
Output High Level	$V_{OH2}$	3006	$V_i = 15V$ $R_T = 10k\Omega$ , $C_T = 3.3nF$ $I_{SOURCE} = 200mA$	12	-	V
UVLO Saturation	$V_{OLS}$	-	$V_i = 6V$ $R_T = 10k\Omega$ , $C_T = 3.3nF$ $I_{SINK} = 1mA$	-	1.1	V
Rise Time	$t_r$	3004	$V_i = 15V$ $R_T = 10k\Omega$ , $C_T = 3.3nF$ $C_L = 1nF$	-	150	ns
Fall Time	$t_f$	3004	$V_i = 15V$ $R_T = 10k\Omega$ , $C_T = 3.3nF$ $C_L = 1nF$	-	150	ns
<b>UNDER-VOLTAGE LOCKOUT SECTION</b>						
Start Threshold	$V_{TH}$	-	$V_i = 15V$ $R_T = 10k\Omega$ , $C_T = 3.3nF$	7.8	9	V
Min Operating Voltage after Turn-on	$V_{MIN}$	-	$V_i = 15V$ $R_T = 10k\Omega$ , $C_T = 3.3nF$	7	8.2	V
Max Duty Cycle	$DC_{MAX}$	-	$V_i = 15V$ $R_T = 10k\Omega$ , $C_T = 3.3nF$	94	100	%
Min Duty Cycle	$DC_{MIN}$	-	$V_i = 15V$ $R_T = 10k\Omega$ , $C_T = 3.3nF$	-	0	%
<b>TOTAL STAND-BY CURRENT</b>						
Start-up current	$I_{ST}$	-	$V_i = 6.5V$ $R_T = 10k\Omega$ , $C_T = 3.3nF$	-	500	$\mu A$
Operating Supply Current	$I_i$	3005	$V_i = 15V$ $R_T = 10k\Omega$ , $C_T = 3.3nF$ $V_{PIN2} = V_{PIN3} = 0V$	-	17	mA
Zener Voltage	$V_{IZ}$	-	$V_i = 15V$ $R_T = 10k\Omega$ , $C_T = 3.3nF$ $I_i = 25mA$	30	-	V

2.3.3 Notes to Electrical Measurement Tables

1. This parameter shall be measured at trip point of latch with  $V_{PIN2} = 0V$ .
2. The gain, A, is defined as follows:

$$A = \frac{\Delta V_{PIN1}}{\Delta V_{PIN3}} \cdot 0V \leq V_{PIN3} \leq 0.8V.$$

2.4 PARAMETER DRIFT VALUES

Unless otherwise specified, the measurements shall be performed at  $T_{amb} = +22 \pm 3^{\circ}C$ .

The test methods and test conditions shall be as per the corresponding test defined in Room Temperature Electrical Measurements.

The drift values ( $\Delta$ ) shall not be exceeded for each characteristic specified. The corresponding absolute limit values for each characteristic shall not be exceeded.

Characteristics	Symbols	Limits			Units
		Drift Value $\Delta$	Absolute		
			Min	Max	
Operating Supply Current	$I_i$	$\pm 0.25$	-	17	mA
Output Voltage	$V_{REF}$	$\pm 0.025$	4.95	5.05	V
Output Low Level	$V_{OL2}$	$\pm 0.05$	-	2.2	V
Output High Level	$V_{OH2}$	$\pm 0.05$	12	-	V

2.5 INTERMEDIATE AND END-POINT ELECTRICAL MEASUREMENTS

Unless otherwise specified, the measurements shall be performed at  $T_{amb} = +22 \pm 3^{\circ}C$ .

The test methods and test conditions shall be as per the corresponding test defined in Room Temperature Electrical Measurements.

The drift values ( $\Delta$ ) shall not be exceeded for each characteristic where specified. The corresponding absolute limit values for each characteristic shall not be exceeded.

Characteristics	Symbols	Limits			Units
		Drift Value $\Delta$	Absolute		
			Min	Max	
Operating Supply Current	$I_i$	$\pm 0.25$	-	17	mA
Output Voltage	$V_{REF}$	$\pm 0.025$	4.95	5.05	V
Output Low Level	$V_{OL2}$	$\pm 0.05$	-	2.2	V
Output High Level	$V_{OH2}$	$\pm 0.05$	12	-	V

2.6 HIGH TEMPERATURE REVERSE BIAS BURN-IN CONDITIONS

Characteristics	Symbols	Test Conditions	Units
Ambient Temperature	$T_{amb}$	+100 (+0 -5)	°C
Supply Voltage	$V_i$	30	V
Junction Temperature	$T_j$	+150 (+0 -5)	°C
Duration	t	≥ 168	Hours

**NOTES:**

- High Temperature Reverse Bias Burn-in may be carried out using the following test circuit:

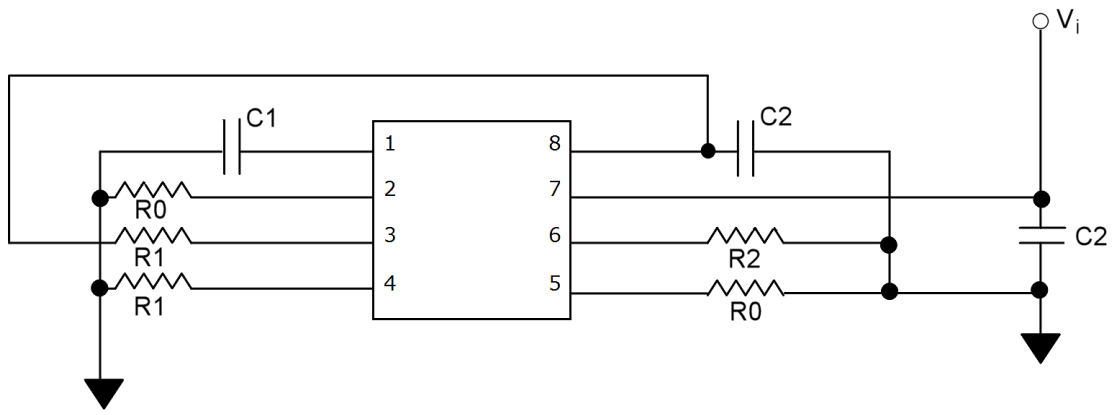

$R0 = 0\Omega$        $C1 = 1nF$   
 $R1 = 10k\Omega$      $C2 = 100nF$   
 $R2 = 1k\Omega$

2.7 POWER BURN-IN CONDITIONS

Characteristics	Symbols	Test Conditions	Units
Ambient Temperature	$T_{amb}$	+125 (+0 -5)	°C
Supply Voltage	$V_i$	18	V
Frequency	f	350	kHz
Junction Temperature	$T_j$	+150 (+0 -5)	°C

**NOTES:**

- Power Burn-in may be carried out using the following test circuit:



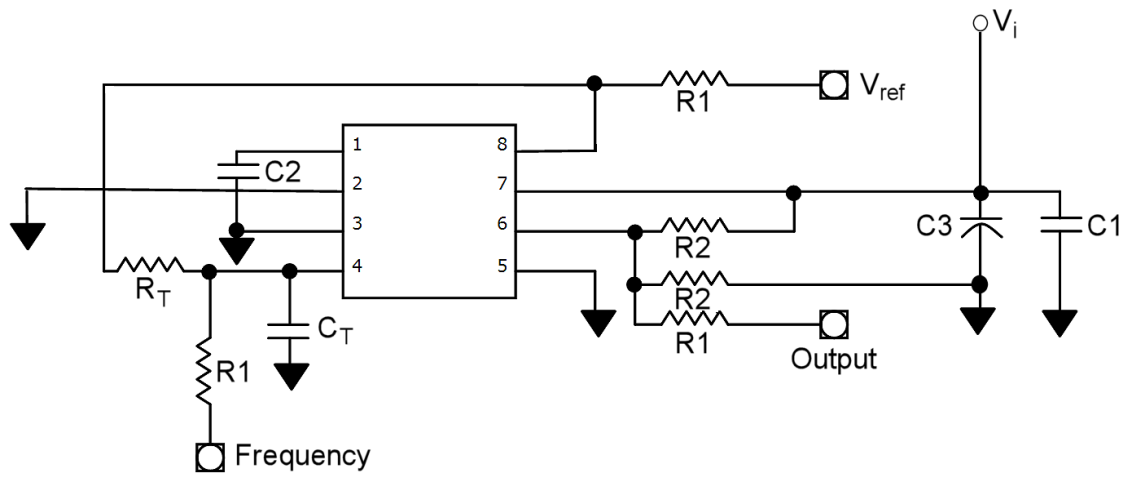

- $R_T = 10k\Omega$
- $C_T = 470pF$
- $R_1 = 1k\Omega$
- $C_1 = 100nF$
- $R_2 = 100k\Omega$
- $C_2 = 1\mu F$
- $C_3 = 470\mu F$

2.8 OPERATING LIFE CONDITIONS  
 The conditions shall be as specified for Power Burn-in.

2.9 TOTAL DOSE RADIATION TESTING

2.9.1 Bias Conditions and Total Dose Level for Total Dose Radiation Testing

Irradiation testing shall be carried out at Dose Rate Window 2 ("Low Rate"): 36 to 360 rad hr<sup>-1</sup>.

No bias shall be applied during irradiation testing (all pins connected to Ground).

The total dose level applied shall be as specified in the component type variant information herein or in the Purchase Order.

2.9.2 Electrical Measurements for Total Dose Radiation Testing

Prior to irradiation testing the devices shall have successfully met Room Temperature Electrical Measurements specified herein.

Unless otherwise stated the measurements shall be performed at T<sub>amb</sub> = +22 ±3°C.

The test methods and test conditions shall be as per the corresponding test defined in Room Temperature Electrical Measurements.

The parameters to be measured during and on completion of irradiation testing are shown below.

Characteristics	Symbols	MIL-STD-883 Test Method	Test Conditions	Limits		Units
				Min	Max	
<b>REFERENCE SECTION</b>						
Output Voltage	V <sub>REF</sub>	-	V <sub>i</sub> = 15V R <sub>T</sub> = 10kΩ, C <sub>T</sub> = 3.3nF I <sub>O</sub> = 1mA	4.85	5.15	V
Line regulation	ΔV <sub>REF_LINE</sub>	-	12V ≤ V <sub>i</sub> ≤ 25V R <sub>T</sub> = 10kΩ, C <sub>T</sub> = 3.3nF	-	20	mV
Load Regulation	ΔV <sub>REF_LOAD</sub>	-	V <sub>i</sub> = 15V R <sub>T</sub> = 10kΩ, C <sub>T</sub> = 3.3nF 1mA ≤ I <sub>O</sub> ≤ 20mA	-	25	mV
Output Short Circuit Current	I <sub>SC</sub>	3011	V <sub>i</sub> = 15V R <sub>T</sub> = 10kΩ, C <sub>T</sub> = 3.3nF	-180	-30	mA
<b>OSCILLATOR SECTION</b>						
Frequency	f <sub>OSC</sub>	-	V <sub>i</sub> = 15V R <sub>T</sub> = 10kΩ, C <sub>T</sub> = 3.3nF	49	65	kHz
Frequency Change with Voltage	Δf <sub>OSC</sub> /ΔV	-	12V ≤ V <sub>i</sub> ≤ 25V R <sub>T</sub> = 10kΩ, C <sub>T</sub> = 3.3nF	-1	1	%
Discharge Current	I <sub>DISCHG</sub>	-	V <sub>i</sub> = 15V R <sub>T</sub> = 10kΩ, C <sub>T</sub> = 3.3nF V <sub>OSC</sub> = 2V	7.8	8.8	mA

Characteristics	Symbols	MIL-STD-883 Test Method	Test Conditions	Limits		Units
				Min	Max	
<b>ERROR AMP SECTION</b>						
Input Voltage	$V_2$	-	$V_i = 15V$ $R_T = 10k\Omega, C_T = 3.3nF$ $V_{PIN1} = 2.5V$	2.45	2.6	V
Input Bias Current	$I_b$	4001	$V_i = 15V$ $R_T = 10k\Omega, C_T = 3.3nF$ $V_{FB} = 5V$	-2.75	2.75	$\mu A$
Open Loop Voltage Gain	$A_{VOL}$	-	$V_i = 15V$ $R_T = 10k\Omega, C_T = 3.3nF$ $2V \leq V_O \leq 4V$	60	-	dB
Power Supply Rejection Ratio	PSRR	4003	$12V \leq V_i \leq 25V$ $R_T = 10k\Omega, C_T = 3.3nF$	60	-	dB
Output Sink Current	$I_{O\_SINK}$	-	$V_i = 15V$ $R_T = 10k\Omega, C_T = 3.3nF$ $V_{PIN2} = 2.7V$ $V_{PIN1} = 1.1V$	2	-	mA
Output Source Current	$I_{O\_SOURCE}$	-	$V_i = 15V$ $R_T = 10k\Omega, C_T = 3.3nF$ $V_{PIN2} = 2.3V$ $V_{PIN1} = 5V$	-	-500	$\mu A$
$V_{OUT}$ High	$V_{OH}$	-	$V_i = 15V$ $R_T = 10k\Omega, C_T = 3.3nF$ $V_{PIN2} = 2.3V$ $R_L = 15k\Omega$ to GROUND	5	-	V
$V_{OUT}$ Low	$V_{OL}$	-	$V_i = 15V$ $R_T = 10k\Omega, C_T = 3.3nF$ $V_{PIN2} = 2.3V$ $R_L = 15k\Omega$ to $V_{ref}$	-	1.1	V
<b>CURRENT SENSE SECTION</b>						
Gain	$G_V$	4004	$V_i = 15V$ $R_T = 10k\Omega, C_T = 3.3nF$ Notes 1, 2	2.85	3.15	V/V
Maximum Input Signal	$V_3$	-	$V_i = 15V$ $R_T = 10k\Omega, C_T = 3.3nF$ $V_{PIN1} = 2.3V$ Note 1	0.9	1.1	V
Supply Voltage Rejection	SVR	-	$12V \leq V_i \leq 25V$ $R_T = 10k\Omega, C_T = 3.3nF$ Note 1	60	-	dB
Input Bias Current	$I_b$	4001	$V_i = 15V$ $R_T = 10k\Omega, C_T = 3.3nF$	-50	50	$\mu A$
Delay to output	$d_o$	3003	$V_i = 15V$ $R_T = 10k\Omega, C_T = 3.3nF$	-	300	ns

Characteristics	Symbols	MIL-STD-883 Test Method	Test Conditions	Limits		Units
				Min	Max	
<b>OUTPUT SECTION</b>						
Output Low Level	$V_{OL1}$	3007	$V_i = 15V$ $R_T = 10k\Omega$ , $C_T = 3.3nF$ $I_{SINK} = 20mA$	-	400	mV
Output Low Level	$V_{OL2}$	3007	$V_i = 15V$ $R_T = 10k\Omega$ , $C_T = 3.3nF$ $I_{SINK} = 200mA$	-	2.2	V
Output High level	$V_{OH1}$	3006	$V_i = 15V$ $R_T = 10k\Omega$ , $C_T = 3.3nF$ $I_{SOURCE} = 20mA$	13	-	V
Output High Level	$V_{OH2}$	3006	$V_i = 15V$ $R_T = 10k\Omega$ , $C_T = 3.3nF$ $I_{SOURCE} = 200mA$	12	-	V
UVLO Saturation	$V_{OLS}$	-	$V_i = 6V$ $R_T = 10k\Omega$ , $C_T = 3.3nF$ $I_{SINK} = 1mA$	-	1.1	V
Rise Time	$t_r$	3004	$V_i = 15V$ $R_T = 10k\Omega$ , $C_T = 3.3nF$ $C_L = 1nF$	-	180	ns
Fall Time	$t_f$	3004	$V_i = 15V$ $R_T = 10k\Omega$ , $C_T = 3.3nF$ $C_L = 1nF$	-	180	ns
<b>UNDER-VOLTAGE LOCKOUT SECTION</b>						
Start Threshold	$V_{TH}$	-	$V_i = 15V$ $R_T = 10k\Omega$ , $C_T = 3.3nF$	7.8	9.5	V
Min Operating Voltage after Turn-on	$V_{MIN}$	-	$V_i = 15V$ $R_T = 10k\Omega$ , $C_T = 3.3nF$	7	8.6	V
Max Duty Cycle	$DC_{MAX}$	-	$V_i = 15V$ $R_T = 10k\Omega$ , $C_T = 3.3nF$	94	100	%
Min Duty Cycle	$DC_{MIN}$	-	$V_i = 15V$ $R_T = 10k\Omega$ , $C_T = 3.3nF$	-	0	%
<b>TOTAL STAND-BY CURRENT</b>						
Start-up current	$I_{ST}$	-	$V_i = 6.5V$ $R_T = 10k\Omega$ , $C_T = 3.3nF$	-	500	$\mu A$
Operating Supply Current	$I_i$	3005	$V_i = 15V$ $R_T = 10k\Omega$ , $C_T = 3.3nF$ $V_{PIN2} = V_{PIN3} = 0V$	-	17	mA
Zener Voltage	$V_{IZ}$	-	$V_i = 15V$ $R_T = 10k\Omega$ , $C_T = 3.3nF$ $I_i = 25mA$	30	-	V

**APPENDIX 'A'**  
**AGREED DEVIATIONS FOR STMICROELECTRONICS (F)**

ITEMS AFFECTED	DESCRIPTION OF DEVIATIONS
Deviations from Screening Tests - Chart F3	External Visual Inspection: The criteria applicable to chip-outs are those described in MIL-STD-883, Test Method 2009, Paras 3.3.6(b) and 3.3.7(a).
Deviations from Qualification and Periodic Tests - Chart F4	External Visual Inspection: The criteria applicable to chip-outs are those described in MIL-STD-883, Test Method 2009, Paras 3.3.6(b) and 3.3.7(a). Operating Life: The temperature limits of MIL-STD-883, Para. 4.5.8(c) may be used.