



**DIODES, MICROWAVE, SILICON, PIN, FAST SWITCHING**  
**BASED ON TYPES DH50151 TO DH50157 AND EH50151 TO**  
**EH50157**

**ESCC Detail Specification No. 5513/031**

Issue 5	November 2016
---------	---------------



**LEGAL DISCLAIMER AND COPYRIGHT**

European Space Agency, Copyright © 2016. All rights reserved.

The European Space Agency disclaims any liability or responsibility, to any person or entity, with respect to any loss or damage caused, or alleged to be caused, directly or indirectly by the use and application of this ESCC publication.

This publication, without the prior permission of the European Space Agency and provided that it is not used for a commercial purpose, may be:

- copied in whole, in any medium, without alteration or modification.
- copied in part, in any medium, provided that the ESCC document identification, comprising the ESCC symbol, document number and document issue, is removed.

**DOCUMENTATION CHANGE NOTICE**

(Refer to <https://escies.org> for ESCC DCR content)

DCR No.	CHANGE DESCRIPTION
1043	Specification upissued to incorporate changes per DCR.

**TABLE OF CONTENTS**

1	GENERAL	6
1.1	SCOPE	6
1.2	APPLICABLE DOCUMENTS	6
1.3	TERMS, DEFINITIONS, ABBREVIATIONS, SYMBOLS AND UNITS	6
1.4	THE ESCC COMPONENT NUMBER AND COMPONENT TYPE VARIANTS	6
1.4.1	The ESCC Component Number	6
1.4.2	Component Type Variants	6
1.5	MAXIMUM RATINGS	9
1.6	HANDLING PRECAUTIONS	9
1.7	PHYSICAL DIMENSIONS AND TERMINAL IDENTIFICATION	10
1.7.1	Ceramic Pill A (2 Leads) - Variants 01, 08, 15, 22, 29, 36, 43	10
1.7.2	Ceramic Pill B - Variants 02, 09, 16, 23, 30, 37, 44	11
1.7.3	Ceramic Pill C (Cathode Lead) - Variants 03, 10, 17, 24, 31, 38, 45	12
1.7.4	Ceramic Pill D (Anode Lead) - Variants 04, 11, 18, 25, 32, 39, 46	13
1.7.5	Ceramic Pill E (2 Leads) - Variants 05, 12, 19, 26, 33, 40, 47	14
1.7.6	Ceramic Pill F (Anode Lead) - Variants 06, 13, 20, 27, 34, 41, 48	15
1.7.7	Ceramic Pill G - Variants 07, 14, 21, 28, 35, 42, 49	16
1.7.8	Ceramic Stripline - Variants 50 to 56	17
1.7.9	Naked Die – Variants 57 to 63	18
1.8	FUNCTIONAL DIAGRAM	18
1.9	MATERIALS AND FINISHES	19
1.9.1	Materials and Finishes of Packaged Components	19
1.9.2	Materials and Finishes of Naked Die Components	19
2	REQUIREMENTS	19
2.1	GENERAL	19
2.1.1	Deviations from the Generic Specification	19
2.1.1.1	Deviations from Qualification and Periodic Tests (Chart F4)	19
2.2	MARKING	19
2.3	DIE SHEAR	20
2.4	TERMINAL STRENGTH	20
2.5	ELECTRICAL MEASUREMENTS AT ROOM, HIGH AND LOW TEMPERATURES	20
2.5.1	Room Temperature Electrical Measurements	20
2.5.2	High and Low Temperatures Electrical Measurements	21
2.6	PARAMETER DRIFT VALUES	22
2.7	INTERMEDIATE AND END-POINT ELECTRICAL MEASUREMENTS	22
2.8	BURN-IN 1 CONDITIONS	23



2.9	BURN-IN 2 CONDITIONS	23
2.10	OPERATING LIFE CONDITIONS	23
APPENDIX 'A'		24

**1 GENERAL**

**1.1 SCOPE**

This specification details the ratings, physical and electrical characteristics and test and inspection data for the component type variants and/or the range of components specified below. It supplements the requirements of, and shall be read in conjunction with, the ESCC Generic Specification listed under Applicable Documents.

**1.2 APPLICABLE DOCUMENTS**

The following documents form part of this specification and shall be read in conjunction with it:

- (a) ESCC Generic Specification No. [5010](#)
- (b) MIL-STD-750, Test Methods and Procedures for Semiconductor Devices

**1.3 TERMS, DEFINITIONS, ABBREVIATIONS, SYMBOLS AND UNITS**

For the purpose of this specification, the terms, definitions, abbreviations, symbols and units specified in ESCC Basic Specification No. [21300](#) shall apply.

**1.4 THE ESCC COMPONENT NUMBER AND COMPONENT TYPE VARIANTS**

**1.4.1 The ESCC Component Number**

The ESCC Component Number shall be constituted as follows:

Example: 551303101

- Detail Specification Reference: 5513031
- Component Type Variant Number: 01 (as required)

**1.4.2 Component Type Variants**

The component type variants applicable to this specification are as follows:

Packaged Components

Variant Number	Based On Type	Package Type / Description	Total Capacitance C <sub>T</sub> (pF) Max	Lead/Terminal Material and Finish (Note 1)		Weight Max (g)
				Anode	Cathode	
01	DH50151	Ceramic Pill A (2 Leads)	0.19	E2	E2	0.02
02	DH50151	Ceramic Pill B	0.19	D7	D7	0.02
03	DH50151	Ceramic Pill C (Cathode Lead)	0.19	D7	E2	0.02
04	DH50151	Ceramic Pill D (Anode Lead)	0.19	E2	D7	0.02
05	DH50151	Ceramic Pill E (2 Leads)	0.19	E2	E2	0.02
06	DH50151	Ceramic Pill F (Anode Lead)	0.19	E2	D7	0.02
07	DH50151	Ceramic Pill G	0.26	D7	A7	0.15
08	DH50152	Ceramic Pill A (2 Leads)	0.21	E2	E2	0.02
09	DH50152	Ceramic Pill B	0.21	D7	D7	0.02
10	DH50152	Ceramic Pill C (Cathode Lead)	0.21	D7	E2	0.02

Variant Number	Based On Type	Package Type / Description	Total Capacitance $C_T$ (pF) Max	Lead/Terminal Material and Finish (Note 1)		Weight Max (g)
				Anode	Cathode	
11	DH50152	Ceramic Pill D (Anode Lead)	0.21	E2	D7	0.02
12	DH50152	Ceramic Pill E (2 Leads)	0.21	E2	E2	0.02
13	DH50152	Ceramic Pill F (Anode Lead)	0.21	E2	D7	0.02
14	DH50152	Ceramic Pill G	0.28	D7	A7	0.15
15	DH50153	Ceramic Pill A (2 Leads)	0.25	E2	E2	0.02
16	DH50153	Ceramic Pill B	0.25	D7	D7	0.02
17	DH50153	Ceramic Pill C (Cathode Lead)	0.25	D7	E2	0.02
18	DH50153	Ceramic Pill D (Anode Lead)	0.25	E2	D7	0.02
19	DH50153	Ceramic Pill E (2 Leads)	0.25	E2	E2	0.02
20	DH50153	Ceramic Pill F (Anode Lead)	0.25	E2	D7	0.02
21	DH50153	Ceramic Pill G	0.32	D7	A7	0.15
22	DH50154	Ceramic Pill A (2 Leads)	0.3	E2	E2	0.02
23	DH50154	Ceramic Pill B	0.3	D7	D7	0.02
24	DH50154	Ceramic Pill C (Cathode Lead)	0.3	D7	E2	0.02
25	DH50154	Ceramic Pill D (Anode Lead)	0.3	E2	D7	0.02
26	DH50154	Ceramic Pill E (2 Leads)	0.3	E2	E2	0.02
27	DH50154	Ceramic Pill F (Anode Lead)	0.3	E2	D7	0.02
28	DH50154	Ceramic Pill G	0.37	D7	A7	0.15
29	DH50155	Ceramic Pill A (2 Leads)	0.36	E2	E2	0.02
30	DH50155	Ceramic Pill B	0.36	D7	D7	0.02
31	DH50155	Ceramic Pill C (Cathode Lead)	0.36	D7	E2	0.02
32	DH50155	Ceramic Pill D (Anode Lead)	0.36	E2	D7	0.02
33	DH50155	Ceramic Pill E (2 Leads)	0.36	E2	E2	0.02
34	DH50155	Ceramic Pill F (Anode Lead)	0.36	E2	D7	0.02
35	DH50155	Ceramic Pill G	0.43	D7	A7	0.15
36	DH50156	Ceramic Pill A (2 Leads)	0.53	E2	E2	0.02
37	DH50156	Ceramic Pill B	0.53	D7	D7	0.02
38	DH50156	Ceramic Pill C (Cathode Lead)	0.53	D7	E2	0.02
39	DH50156	Ceramic Pill D (Anode Lead)	0.53	E2	D7	0.02
40	DH50156	Ceramic Pill E (2 Leads)	0.53	E2	E2	0.02
41	DH50156	Ceramic Pill F (Anode Lead)	0.53	E2	D7	0.02
42	DH50156	Ceramic Pill G	0.6	D7	A7	0.15
43	DH50157	Ceramic Pill A (2 Leads)	0.73	E2	E2	0.02
44	DH50157	Ceramic Pill B	0.73	D7	D7	0.02
45	DH50157	Ceramic Pill C (Cathode Lead)	0.73	D7	E2	0.02

Variant Number	Based On Type	Package Type / Description	Total Capacitance $C_T$ (pF) Max	Lead/Terminal Material and Finish (Note 1)		Weight Max (g)
				Anode	Cathode	
46	DH50157	Ceramic Pill D (Anode Lead)	0.73	E2	D7	0.02
47	DH50157	Ceramic Pill E (2 Leads)	0.73	E2	E2	0.02
48	DH50157	Ceramic Pill F (Anode Lead)	0.73	E2	D7	0.02
49	DH50157	Ceramic Pill G	0.8	D7	A7	0.15
50	DH50151	Ceramic Stripline	0.2	D7	D7	0.02
51	DH50152	Ceramic Stripline	0.22	D7	D7	0.02
52	DH50153	Ceramic Stripline	0.26	D7	D7	0.02
53	DH50154	Ceramic Stripline	0.31	D7	D7	0.02
54	DH50155	Ceramic Stripline	0.37	D7	D7	0.02
55	DH50156	Ceramic Stripline	0.6	D7	D7	0.02
56	DH50157	Ceramic Stripline	0.74	D7	D7	0.02

Naked Die Components (Note 2)

Variant Number	Based On Type	Junction Capacitance $C_J$ (pF) Max	Total Capacitance $C_T$ (pF) Max (Note 3)
57	EH50151	0.06	0.26
58	EH50152	0.08	0.28
59	EH50153	0.12	0.32
60	EH50154	0.17	0.37
61	EH50155	0.23	0.43
62	EH50156	0.4	0.6
63	EH50157	0.6	0.8

**NOTES:**

1. The lead/terminal material and finish shall be in accordance with the requirements of ESCC Basic Specification No. [23500](#).
2. For Naked Die Components, Variants 57 to 63, the default package selected for assembly of the Packaged Test Sublot shall be Ceramic Pill G. At the Manufacturer's option, any of the other packages specified herein with a Variant for the same die may be selected. The die applicable to each Variant is indicated by the based on type number.
3. In cases where the default package is not selected for the Packaged Test Sublot, the Total Capacitance limit of the selected package shall apply.



1.5 MAXIMUM RATINGS

The maximum ratings shall not be exceeded at any time during use or storage.

Maximum ratings shall only be exceeded during testing to the extent specified in this specification and when stipulated in Test Methods and Procedures of the ESCC Generic Specification.

Characteristics	Symbols	Maximum Ratings	Unit	Remarks
DC Reverse Voltage	$V_{Rmax}$	-150	V	$I_R = 10\mu A$
DC Forward Current (Continuous) Variants 01 to 06, 08 to 13, 15 to 20, 22 to 27: Variants 07, 14, 21, 28: Variants 29 to 34, 36 to 41, 43 to 48: Variants 35, 42, 49: Variants 50 to 56:	$I_{Fmax}$	150 240 180 300 90	mA	Note 1
RF Power Dissipation Variants 01 to 06, 08 to 13, 15 to 20, 22 to 27: Variants 07, 14, 21, 28: Variants 29 to 34, 36 to 41, 43 to 48: Variants 35, 42, 49: Variants 50 to 56:	$P_{tot}$	0.5 0.83 0.62 1.25 0.3	W	Note 2
Operating Temperature Range	$T_{op}$	-55 to +150	°C	$T_{case}$
Storage Temperature Range	$T_{stg}$	-65 to +175	°C	
Junction Temperature	$T_j$	+150	°C	
Thermal Resistance, Junction-to-Case Variants 01 to 06, 08 to 13, 15 to 20, 22 to 27: Variants 07, 14, 21, 28, 57 to 60: Variants 29 to 34, 36 to 41, 43 to 48: Variants 35, 42, 49, 61 to 63: Variants 50 to 56:	$R_{th(j-c)}$	150 90 120 60 250	°C/W	Note 3
Soldering Temperature	$T_{sol}$	+230	°C	Note 4

**NOTES:**

- At  $T_{case} \leq +75^\circ C$ . For  $T_{case} > +75^\circ C$ , derate linearly to 0A at  $T_{case} = +150^\circ C$ .
- At  $T_{case} \leq +75^\circ C$ . For  $T_{case} > +75^\circ C$ , derate linearly to 0W at  $T_{case} = +150^\circ C$ .
- Thermal Resistance ratings for Naked Die Components, Variants 57 to 63, refer to the Packaged Test Sublot assembled in the default Ceramic Pill G package. In cases where the default package is not used, the Thermal Resistance rating associated with the package used and the same die shall apply.
- Duration 5 seconds maximum and the same terminal shall not be resoldered until 3 minutes have elapsed. Only applicable to Variants 01 to 56 (Packaged Components).

1.6 HANDLING PRECAUTIONS

These devices are susceptible to damage by electrostatic discharge. Therefore, suitable precautions shall be employed for protection during all phases of manufacture, testing, packaging, shipment and any handling.

These components are categorised as Class 2 per ESCC Basic Specification No. [23800](#) with a Minimum Critical Path Failure Voltage of 1400V.

1.7 PHYSICAL DIMENSIONS AND TERMINAL IDENTIFICATION

1.7.1 Ceramic Pill A (2 Leads) - Variants 01, 08, 15, 22, 29, 36, 43

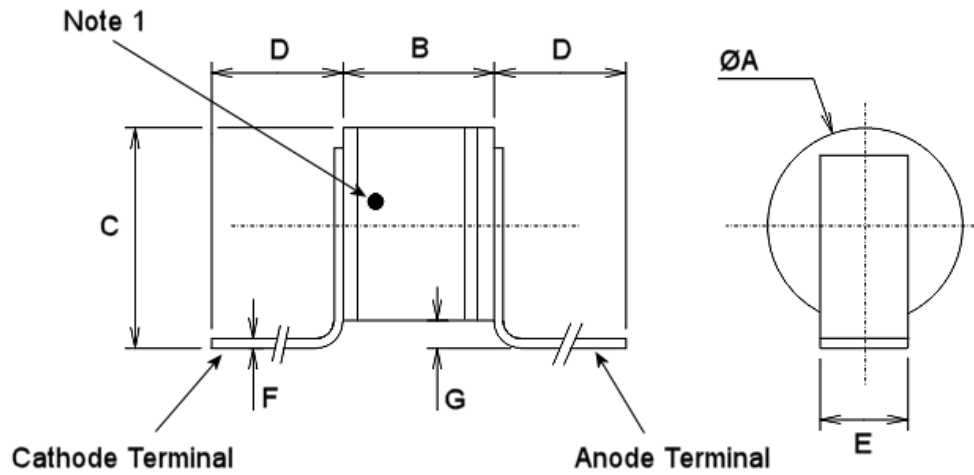

Symbols	Dimensions mm		Remarks
	Min	Max	
ØA	1.07	1.47	
B	0.95	1.35	
C	1.3	1.9	Both terminals
D	2.5	-	
E	0.55	0.65	Both terminals
F	0.06	0.1	Both terminals
G	0.1	0.5	Both terminals

**NOTES:**

- Terminal identification: The body shall be marked at a suitable location near the cathode terminal with a black dot.

1.7.2 Ceramic Pill B - Variants 02, 09, 16, 23, 30, 37, 44

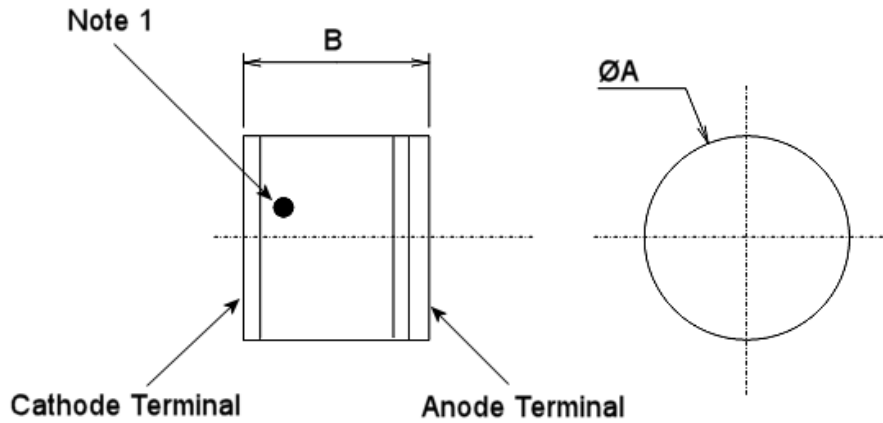

Symbols	Dimensions mm	
	Min	Max
$\text{Ø}A$	1.07	1.47
B	0.95	1.35

**NOTES:**

1. Terminal identification: The body shall be marked at a suitable location near the cathode terminal with a black dot.

1.7.3 Ceramic Pill C (Cathode Lead) - Variants 03, 10, 17, 24, 31, 38, 45

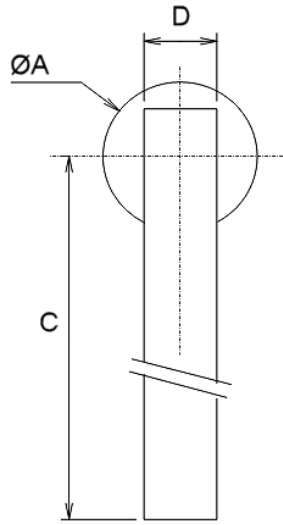
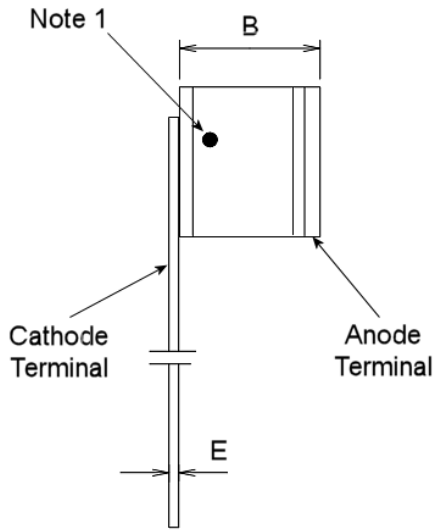

Symbols	Dimensions mm	
	Min	Max
ØA	1.07	1.47
B	0.95	1.35
C	5	-
D	0.55	0.65
E	0.06	0.1

**NOTES:**

- Terminal identification: The body shall be marked at a suitable location near the cathode terminal with a black dot.

1.7.4 Ceramic Pill D (Anode Lead) - Variants 04, 11, 18, 25, 32, 39, 46

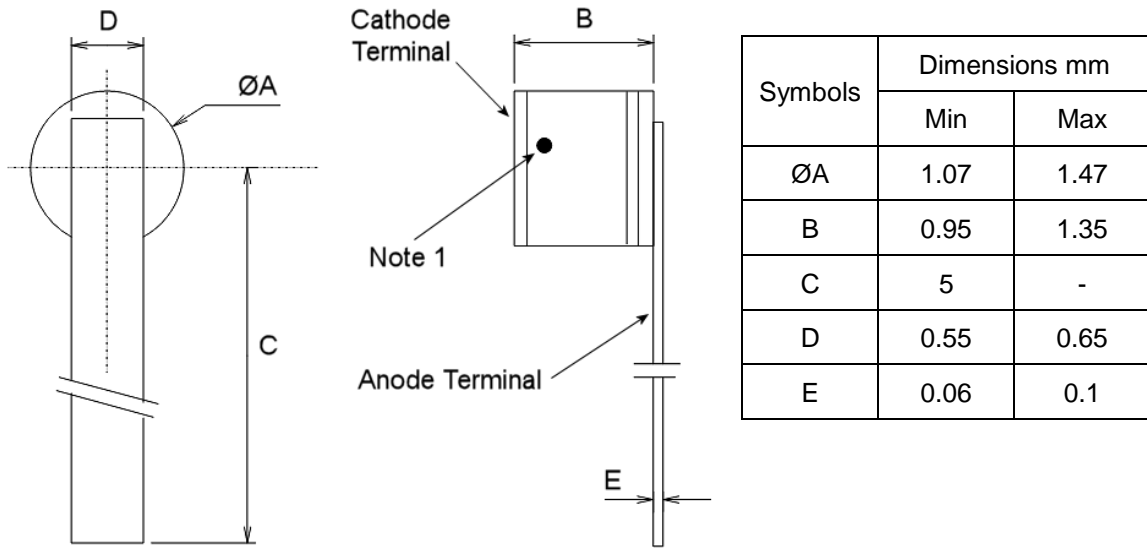

**NOTES:**

1. Terminal identification: The body shall be marked at a suitable location near the cathode terminal with a black dot.

1.7.5 Ceramic Pill E (2 Leads) - Variants 05, 12, 19, 26, 33, 40, 47

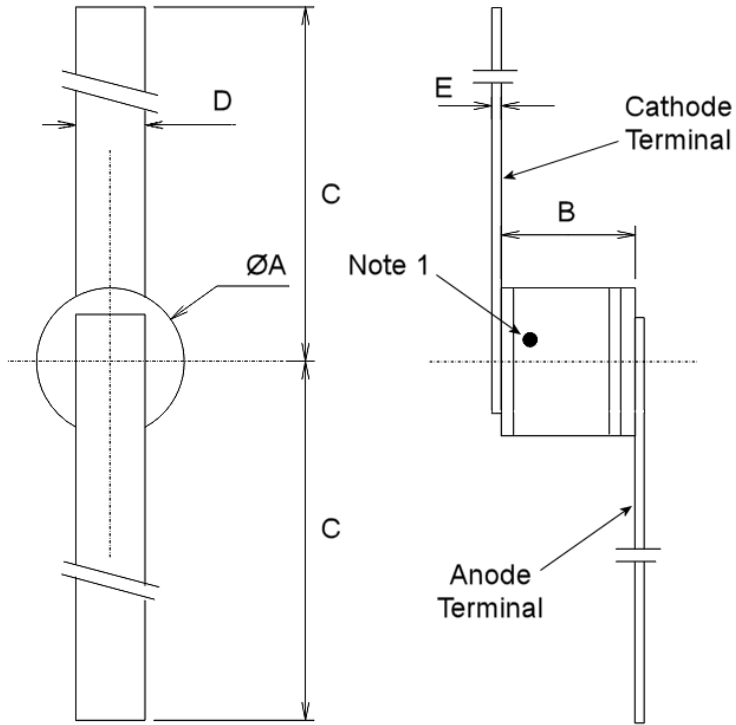

Symbols	Dimensions mm		Remarks
	Min	Max	
$\varnothing A$	1.07	1.47	
B	0.95	1.35	
C	5	-	
D	0.55	0.65	Both terminals
E	0.06	0.1	Both terminals

**NOTES:**

1. Terminal identification: The body shall be marked at a suitable location near the cathode terminal with a black dot.

1.7.6 Ceramic Pill F (Anode Lead) - Variants 06, 13, 20, 27, 34, 41, 48

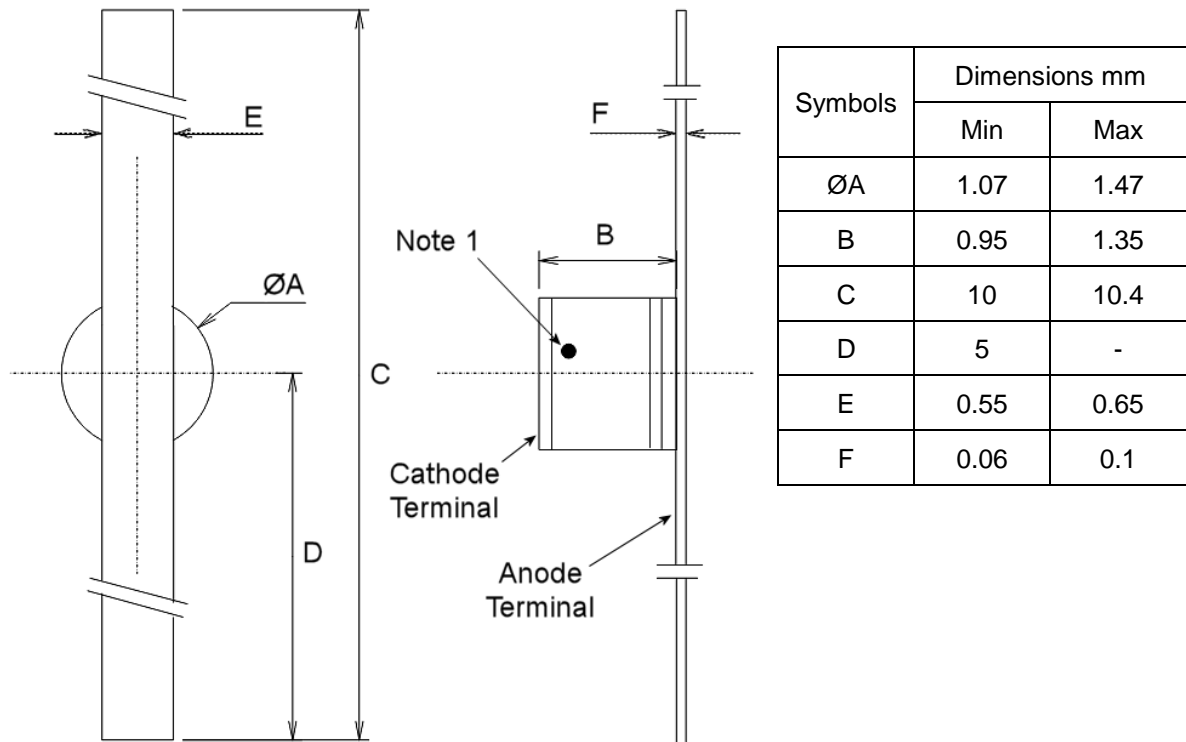

**NOTES:**

1. Terminal identification: The body shall be marked at a suitable location near the cathode terminal with a black dot.

1.7.7 Ceramic Pill G - Variants 07, 14, 21, 28, 35, 42, 49

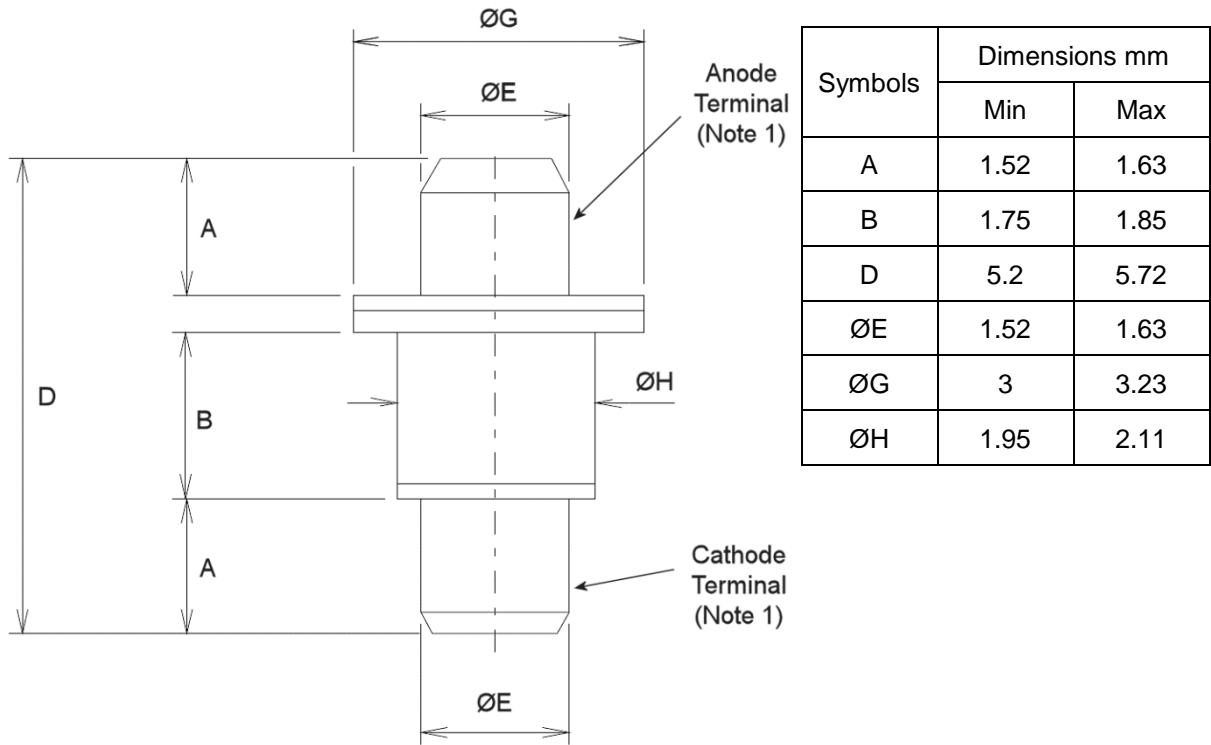

**NOTES:**

- Terminal identification shall be by means of the physical configuration of the package.



1.7.8 Ceramic Stripline - Variants 50 to 56

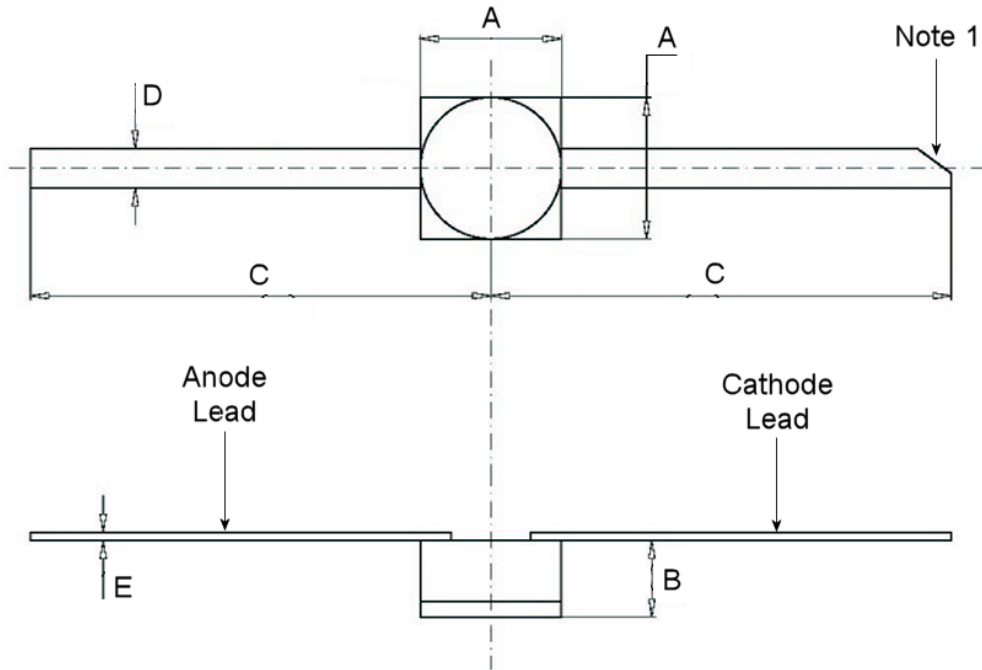

Symbols	Dimensions mm		Remarks
	Min	Max	
A	1.68	1.88	
B	0.91	1.01	
C	6.15	6.55	
D	0.45	0.55	Both leads
E	0.08	0.12	Both leads

**NOTES:**

1. Terminal identification: The end of the cathode lead shall have a 45° chamfer.

1.7.9 Naked Die – Variants 57 to 63

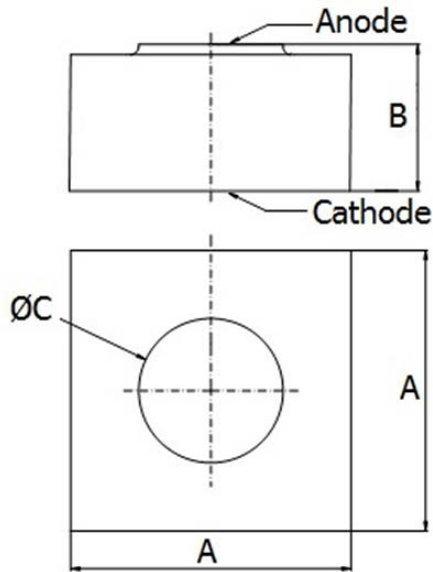

Symbols	Dimensions mm		Remarks
	Min	Max	
A	0.34	0.4	
B	0.16	0.26	
ØC	0.06	0.1	Variant 57
	0.08	0.12	Variant 58
	0.09	0.15	Variant 59
	0.11	0.18	Variant 60
	0.14	0.2	Variant 61
	0.19	0.25	Variant 62
	0.24	0.31	Variant 63

**NOTES:**

- Terminal identification shall be by means of the physical configuration.

1.8 FUNCTIONAL DIAGRAM

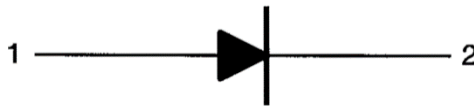

- Anode
- Cathode

**NOTES:**

- For Variants 50 to 56, the lid is isolated from the terminals.

## 1.9 MATERIALS AND FINISHES

### 1.9.1 Materials and Finishes of Packaged Components

For Variants 01 to 56, the materials and finishes shall be as follows:

- (a) Case  
The case shall be hermetically sealed and have a ceramic body with a metal base and lid.
- (b) Leads/Terminals  
As specified in Component Type Variants.

### 1.9.2 Materials and Finishes of Naked Die Components

For Variants 57 to 63, the materials and finishes shall be as follows:

- (a) Bond pad  
The bond pad metallisation shall be TiPtAu with a layer of vacuum-deposited gold of thickness 0.7µm minimum.
- (b) Die backface  
The die backface metallisation shall be TiPtAu with a layer of gold of thickness 0.7µm minimum.

## 2 REQUIREMENTS

### 2.1 GENERAL

The complete requirements for procurement of the components specified herein are as stated in this specification and the ESCC Generic Specification. Permitted deviations from the Generic Specification, applicable to this specification only, are listed below.

Permitted deviations from the Generic Specification and this Detail Specification, formally agreed with specific Manufacturers on the basis that the alternative requirements are equivalent to the ESCC requirement and do not affect the component's reliability, are listed in the appendices attached to this specification.

#### 2.1.1 Deviations from the Generic Specification

##### 2.1.1.1 *Deviations from Qualification and Periodic Tests (Chart F4)*

- (a) Mechanical Shock: Shall not be performed.
- (b) Vibration: Shall not be performed.
- (c) Constant Acceleration: Shall not be performed.

### 2.2 MARKING

The marking shall be in accordance with the requirements of ESCC Basic Specification No. [21700](#) and as follows.

The information to be marked on the component shall be:

- (a) Terminal identification, as specified in Physical Dimensions and Terminal Identification.
- (b) The ESCC qualified components symbol (for ESCC qualified components only).
- (c) The ESCC Component Number.
- (d) Traceability information.

2.3 DIE SHEAR

In those cases where package clearances are such that a die shear test is not practicable, the die shall be pushed away with a suitable tool. The force required to remove the die need not be recorded. The die attachment area shall be inspected and the component shall be considered acceptable if more than 50% of the semiconductor material remains.

2.4 TERMINAL STRENGTH

The test conditions for terminal strength, tested as specified in the ESCC Generic Specification, shall be as follows:

- For Variants 01, 03 to 06, 08, 10 to 13, 15, 17 to 20, 22, 24 to 27, 29, 31 to 34, 36, 38 to 41, 43, 45 to 48, 50 to 56: Test Condition A, tension, with a force of 1.25N for duration 10s.
- For Variants 02, 07, 09, 14, 16, 21, 23, 28, 30, 35, 37, 42, 44, 49, 57 to 63: shall not be performed.

2.5 ELECTRICAL MEASUREMENTS AT ROOM, HIGH AND LOW TEMPERATURES

2.5.1 Room Temperature Electrical Measurements

The measurements shall be performed at  $T_{amb} = +22 \pm 3^{\circ}C$ .

Characteristics	Symbols	MIL-STD-750 Test Method	Test Conditions	Limits		Units
				Min	Max	
Reverse Current 1 (Note 1)	$I_{R1}$	4016	$V_R = -150V$	-	10	$\mu A$
Reverse Current 2 (Note 1)	$I_{R2}$	4016	$V_R = -75V$	-	500	nA
Forward Voltage (Note 1)	$V_F$	4011	$I_F = 10mA$	-	1.1	V
Thermal Resistance, Junction-to-Case (Note 2) Variants 01 to 06, 08 to 13, 15 to 20, 22 to 27, 50 to 56: Variants 07, 14, 21, 28 to 34, 36 to 41, 43 to 48, 57 to 61: Variants 35, 42, 49, 62, 63:	$R_{th(j-c)}$	3101	Note 3  $P = 0.25W$  $P = 0.5W$  $P = 1W$	-	Note 4	$^{\circ}C/W$
Total Capacitance (Note 2)	$C_T$	4001	$V_R = -50V$ $f = 1MHz$	-	Note 5	pF
Junction Capacitance (Note 6)	$C_J$	4001	$V_R = -50V$ $f = 1MHz$	-	Note 5	pF
Forward Series Resistance (Note 1) Variants 01 to 07, 50, 57: Variants 08 to 14, 51, 58: Variants 15 to 21, 52, 59: Variants 22 to 28, 53, 60: Variants 29 to 35, 54, 61: Variants 36 to 42, 55, 62: Variants 43 to 49, 56, 63:	$R_{SF}$	4056	$I_F = 10mA$ $f = 120MHz$	- - - - - - -	2 1.7 1.5 1.4 1 0.8 0.6	$\Omega$

Characteristics	Symbols	MIL-STD-750 Test Method	Test Conditions	Limits		Units
				Min	Max	
Minority Carrier Lifetime (Note 7)	$\tau_L$	4031	$I_F = 10\text{mA}$ $I_R = 6\text{mA}$			ns
Variants 01 to 07, 50, 57:				160	-	
Variants 08 to 14, 51, 58:				185	-	
Variants 15 to 21, 52, 59:				240	-	
Variants 22 to 28, 53, 60:				400	-	
Variants 29 to 35, 54, 61:				440	-	
Variants 36 to 42, 55, 62:				640	-	
Variants 43 to 49, 56, 63:				760	-	

**NOTES:**

1. This characteristic applies to all Variants tested during Charts F2 and F3 of the Generic Specification.
2. 5. This characteristic applies to Variants 01 to 56 (Packaged Components) and Variants 57 to 63 (Packaged Test Sublot samples for Naked Die Components), tested only during Chart F3 of the Generic Specification.
3. Pulsed measurement, pulse width = 10ms.
4. See Maximum Ratings for the applicable limits.
5. See Component Type Variants for the applicable limits.
6. This characteristic applies only to Variants 57 to 63 (Naked Die Components), tested only during Chart F2 of the Generic Specification.
7. Only performed during Chart F2 of the Generic Specification, on a sample of 27 dice per wafer. In the event of any failure, a 100% inspection shall be performed and all failures shall be clearly identified.

2.5.2 High and Low Temperatures Electrical Measurements

The measurements shall be performed only at  $T_{amb} = +150 (+0 -3)^\circ\text{C}$ .

Characteristics	Symbols	MIL-STD-750 Test Method	Test Conditions Note 1	Limits		Units
				Min	Max	
Reverse Current 2 (Note 2)	$I_{R2}$	4016	$V_R = -75\text{V}$	-	50	$\mu\text{A}$

**NOTES:**

1. Measurements shall be performed on a sample basis as specified in the Generic Specification.
2. This characteristic applies to all Variants tested during Charts F2 and F3 of the Generic Specification.

2.6 PARAMETER DRIFT VALUES

Unless otherwise specified, the measurements shall be performed at  $T_{amb} = +22 \pm 3^{\circ}C$ .

The test methods and test conditions shall be as per the corresponding test defined in Room Temperature Electrical Measurements.

The drift values ( $\Delta$ ) shall not be exceeded for each characteristic specified. The corresponding absolute limit values for each characteristic shall not be exceeded.

Characteristics	Symbols	Limits			Units
		Drift Value (1) $\Delta$	Absolute		
			Min	Max	
Reverse Current 2	$I_{R2}$	$\pm 50$ or (2) $\pm 100\%$	-	500	nA
Forward Voltage	$V_F$	$\pm 5\%$	-	1.1	V
Total Capacitance (Note 3)	$C_T$	$\pm 5\%$ (4) or $\pm 10\%$ (5)	-	Note 6	pF

**NOTES:**

- $\Delta 1 = \Delta 2$ .
- Whichever is the greater referred to the initial value.
- This characteristic applies to Variants 01 to 56 (Packaged Components) and Variants 57 to 63 (Packaged Test Sublot samples for Naked Die Components).
- Applicable drift value for  $C_T > 0.5pF$  and rounded upwards to the nearest 0.01pF.
- Applicable drift value for  $C_T \leq 0.5pF$  and rounded upwards to the nearest 0.01pF.
- See Component Type Variants for the applicable limits.

2.7 INTERMEDIATE AND END-POINT ELECTRICAL MEASUREMENTS

Unless otherwise specified, the measurements shall be performed at  $T_{amb} = +22 \pm 3^{\circ}C$ .

The test methods and test conditions shall be as per the corresponding test defined in Room Temperature Electrical Measurements.

The limit values for each characteristic shall not be exceeded.

Characteristics	Symbols	Limits		Units
		Min	Max	
Reverse Current 1	$I_{R1}$	-	10	$\mu A$
Reverse Current 2	$I_{R2}$	-	500	nA
Forward Voltage	$V_F$	-	1.1	V
Total Capacitance (Note 1)	$C_T$	-	Note 2	pF

**NOTES:**

- This characteristic applies to Variants 01 to 56 (Packaged Components) and Variants 57 to 63 (Packaged Test Sublot samples for Naked Die Components).
- See Component Type Variants for the applicable limits.

2.8 BURN-IN 1 CONDITIONS

Characteristics	Symbols	Test Conditions	Units
Ambient Temperature	T <sub>amb</sub>	+150 (+0 -3)	°C
Reverse Voltage (Note 1)	V <sub>R</sub>	-112.5	V

**NOTES:**

1. Upon completion of Burn-in 1, the test voltage shall be maintained until T<sub>amb</sub> < +35°C.

2.9 BURN-IN 2 CONDITIONS

Characteristics	Symbols	Test Conditions	Units
Case Temperature	T <sub>case</sub>	+125 (+0 -3)	°C
Forward Current	I <sub>F</sub>		mA
Variants 01 to 06, 08 to 13, 15 to 20, 22 to 27:		50	
Variants 07, 14, 21, 28, 57 to 60:		80	
Variants 29 to 34, 36 to 41, 43 to 48:		60	
Variants 35, 42, 49, 61 to 63:		100	
Variants 50 to 56:		30	

2.10 OPERATING LIFE CONDITIONS

The conditions shall be as specified for Burn-in 2.

**APPENDIX 'A'**  
**AGREED DEVIATIONS FOR COBHAM MICROWAVE (F)**

Items Affected	Description of Deviations
Deviations from Generic Specification: Special In-Process Controls (Chart F2)	<p>SEM Inspection: From each wafer selected for SEM Inspection, the sample of three dice shall be selected after die separation.</p> <p>Bond Strength: The following pre-seal bond strength shall apply:</p> <ul style="list-style-type: none"> <li>• 0.03N minimum</li> </ul>
Deviations from Generic Specification: Screening Tests (Chart F3)	<p>Radiographic Inspection:</p> <ul style="list-style-type: none"> <li>• Shall not be performed on Packaged Test Sublot samples for Naked Die Components.</li> <li>• May be performed without serialisation and at any point during Chart F3. Any components found to fail Radiographic Inspection shall be removed from the lot.</li> <li>• May be performed in the X and Z axes only.</li> </ul>
Deviations from Generic Specification: Qualification and Periodic Tests for Packaged Components and Naked Die Components (Charts F4A and F4B)	<p>For the De-encapsulation Subgroup, the Internal Visual Inspection, Bond Strength and Die Shear tests may be replaced by measurements verifying the die solder integrity and wire integrity, as follows:</p> <ul style="list-style-type: none"> <li>• Thermal Impedance test in accordance with MIL-STD-750, Test Method <a href="#">3101</a>. <ul style="list-style-type: none"> <li>• For Variants 01 to 06, 08 to 13, 15 to 20, 22 to 27, 50 to 56: <math>P_D = 0.25W</math>.</li> <li>• For Variants 07, 14, 21, 28 to 34, 36 to 41, 43 to 48, 57 to 61: <math>P_D = 0.5W</math>.</li> <li>• For Variants 35, 42, 49, 62, 63: <math>P_D = 1W</math>.</li> </ul> </li> </ul> <p>The Thermal Impedance shall be measured and shall not exceed the applicable value of Thermal Resistance, Junction-to-Case specified in Maximum Ratings.</p> <ul style="list-style-type: none"> <li>• Forward Voltage test in accordance with MIL-STD-750, Test Method <a href="#">4011</a>. <ul style="list-style-type: none"> <li>• For Variants 01 to 49 and 57 to 63: <math>I_F = 100mA</math></li> <li>• For Variants 50 to 56: <math>I_F = 90mA</math>.</li> </ul> </li> </ul> <p>The Forward Voltage shall be measured and shall not exceed 1.2V.</p>