



**CONNECTORS, ELECTRICAL, SINGLE-IN-LINE,
MICROMINIATURE**

BASED ON TYPE MTB 1

ESCC Detail Specification No. 3401/031

| | |
|---------|---------------|
| Issue 8 | November 2017 |
|---------|---------------|



LEGAL DISCLAIMER AND COPYRIGHT

European Space Agency, Copyright © 2017. All rights reserved.

The European Space Agency disclaims any liability or responsibility, to any person or entity, with respect to any loss or damage caused, or alleged to be caused, directly or indirectly by the use and application of this ESCC publication.

This publication, without the prior permission of the European Space Agency and provided that it is not used for a commercial purpose, may be:

- copied in whole, in any medium, without alteration or modification.
- copied in part, in any medium, provided that the ESCC document identification, comprising the ESCC symbol, document number and document issue, is removed.

DOCUMENTATION CHANGE NOTICE

(Refer to <https://escies.org> for ESCC DCR content)

| DCR No. | CHANGE DESCRIPTION |
|---------|--|
| 1097 | Specification upissued to incorporate changes per DCR. |

TABLE OF CONTENTS

| | | |
|--------|---|----|
| 1 | GENERAL | 6 |
| 1.1 | SCOPE | 6 |
| 1.2 | COMPONENT TYPE VARIANTS / RANGE OF COMPONENTS | 6 |
| 1.2.1 | Insert Sizes for Variant 01 | 6 |
| 1.2.2 | Insert Sizes for Variant 02 | 6 |
| 1.3 | MAXIMUM RATINGS | 6 |
| 1.4 | PARAMETER DERATING INFORMATION | 6 |
| 1.5 | PHYSICAL DIMENSIONS | 6 |
| 2 | APPLICABLE DOCUMENTS | 7 |
| 3 | TERMS, DEFINITIONS, ABBREVIATIONS, SYMBOLS AND UNITS | 17 |
| 4 | REQUIREMENTS | 17 |
| 4.1 | GENERAL | 17 |
| 4.2 | DEVIATIONS FROM GENERIC SPECIFICATION | 17 |
| 4.2.1 | Deviations from Special In-process Controls | 17 |
| 4.2.2 | Deviations from Final Production Tests (Chart II) | 17 |
| 4.2.3 | Deviations from Burn-in and Electrical Measurements (Chart III) | 17 |
| 4.2.4 | Deviations from Qualification Tests (Chart IV) | 17 |
| 4.2.5 | Deviations from Lot Acceptance Tests (Chart V) | 18 |
| 4.3 | MECHANICAL REQUIREMENTS | 18 |
| 4.3.1 | Dimension Check | 18 |
| 4.3.2 | Weight | 18 |
| 4.3.3 | Contact Capability | 18 |
| 4.3.4 | Contact Retention (In Insert) | 18 |
| 4.3.5 | Mating and Unmating Forces | 18 |
| 4.3.6 | Insert Retention (In Shell) | 18 |
| 4.3.7 | Jackscrew Retention | 18 |
| 4.3.8 | Contact Insertion and Withdrawal Forces | 18 |
| 4.3.9 | Engagement and Separation Forces | 19 |
| 4.3.10 | Oversize Pin Exclusion | 19 |
| 4.3.11 | Probe Damage | 19 |
| 4.3.12 | Solderability | 19 |
| 4.3.13 | Latching | 19 |
| 4.4 | MATERIALS AND FINISHES | 19 |
| 4.4.1 | Inserts | 19 |
| 4.4.2 | Contacts | 19 |
| 4.4.3 | Guide Posts | 20 |

| | | |
|------------|--|----|
| 4.4.4 | Latching | 20 |
| 4.4.5 | Insulated Wires | 20 |
| 4.4.6 | Uninsulated Solid Wires | 20 |
| 4.4.7 | Rear Potting | 20 |
| 4.5 | MARKING | 20 |
| 4.5.1 | General | 20 |
| 4.5.2 | Contact Identification | 20 |
| 4.5.3 | The ESCC Component Number | 20 |
| 4.5.4 | Characteristics | 21 |
| 4.5.5 | Traceability Information | 22 |
| 4.6 | ELECTRICAL MEASUREMENTS | 22 |
| 4.6.1 | Electrical Measurements at Room Temperature | 22 |
| 4.6.2 | Electrical Measurements at High and Low Temperatures | 22 |
| 4.6.3 | Circuits for Electrical Measurements (Figure 4) | 22 |
| 4.7 | BURN-IN AND ELECTRICAL MEASUREMENTS | 22 |
| 4.8 | ENVIRONMENTAL AND ENDURANCE TESTS (CHARTS IV AND V OF ESCC GENERIC SPECIFICATION NO. 3401) | 24 |
| 4.8.1 | Measurements and Inspections on Completion of Environmental Tests | 24 |
| 4.8.2 | Measurements and Inspections at Intermediate Points during Endurance Tests | 24 |
| 4.8.3 | Measurements and Inspections on Completion of Endurance Tests | 24 |
| 4.8.4 | Conditions for Operating Life Test (Part of Endurance Testing) | 24 |
| 4.8.5 | Electrical Circuits for Operating Life Test (Figure 5) | 24 |
| 4.8.6 | Conditions for High Temperature Storage Test (Part of Endurance Testing) | 24 |
| APPENDIX A | | 27 |

1 GENERAL

1.1 SCOPE

This specification details the ratings, physical and electrical characteristics, test and inspection data for Connectors, Electrical, Single-in-Line, Microminiature, with non-removable crimp-type contacts and their associated insulated wires and uninsulated solid wires and Solder Bucket based on Type MTB 1.

It shall be read in conjunction with:

- (a) ESCC Generic Specification No. [3401](#), Connectors, Electrical, Non-Filtered, Circular and Rectangular

the requirements of which are supplemented herein.

1.2 COMPONENT TYPE VARIANTS / RANGE OF COMPONENTS

The single-in-line connectors specified herein are scheduled in Table 1(a). Alignment is effected by 2 guide posts; the posts are located at either end of the receptacle.

1.2.1 Insert Sizes for Variant 01

These range from 5 to 50. Since 4 cavities are used (2 guide posts and 2 epoxy-filled cavities at either end) the number of available contact positions ranges from 1 to 46.

1.2.2 Insert Sizes for Variant 02

These range from 6 to 50. Since 5 cavities are used (2 guide posts and 2 epoxy-filled cavities at either end plus 1 cavity for latching) the number of available contact positions ranges from 1 to 45.

Polarisation may be achieved by means of additional guide posts (according to Customer requirements). The different sizes of associated insulated wires and uninsulated solid wires are given in Figure 2.

1.3 MAXIMUM RATINGS

The maximum ratings, which shall not be exceeded at any time during use or storage, applicable to the connectors specified herein, are as scheduled in Table 1(b).

1.4 PARAMETER DERATING INFORMATION

The applicable derating information for the connectors specified herein is shown in Figure 1(a).

1.5 PHYSICAL DIMENSIONS

The physical dimensions of the connectors, insulated wires and uninsulated solid wires specified herein are shown in Figure 2.

2 APPLICABLE DOCUMENTS

The following documents form part of this specification and shall be read in conjunction with it:

- (a) ESCC Generic Specification No. 3401 for Connectors, Electrical, Non-Filtered, Circular and Rectangular.
- (b) ESCC Detail Specification No. 3901/013, PTFE Insulated Wires and Cables, 600V, -100 to +200°C.
- (c) QQ-W-343, Wires, Electrical, Uninsulated.
- (d) MIL-DTL-45204, Gold-Plating, Electro-deposited.
- (e) SAE-AMS 2418, Copper-Plating.

TABLE 1(a) - TYPE VARIANTS

| Variant | Latching Option |
|---------|------------------|
| 01 | Without latching |
| 02 | With latching |

TABLE 1(b) - MAXIMUM WEIGHTS

| Description | | Weight (g) |
|---|---------------------|------------|
| Contact | Male | 0.02 |
| | Female | 0.02 |
| | Male Solder | 0.04 |
| | Female Solder | 0.04 |
| Body (per contact cavity) | Plug | 0.21 |
| | Receptacle | 0.006 |
| Guide Post, Stainless Steel (2 per connector) | - | 0.035 |
| Wire | Figures 2.2 and 2.3 | |

TABLE 1(c) - MATING AND UNMATING FORCES

| Description | Mating | | Unmating | |
|-------------|--------|------|----------|------|
| | Min | Max | Min | Max |
| Per contact | - | 2.2N | 0.14N | 2.2N |

TABLE 1(d) - MAXIMUM RATINGS

| No. | Characteristics | Symbol | Maximum Rating | Unit |
|-----|--|-----------|----------------|------|
| 1 | Working Voltage (Sea Level) | U_R | 150 | Vrms |
| 2 | Rated Current (AWG26 and Uninsulated Solid Wire) | I_R | 2.5 | A |
| 3 | Rated Current (AWG28) | I_R | 1.5 | A |
| 4 | Operating Temperature Range | T_{op} | -55 to +125 | °C |
| 5 | Storage Temperature Range | T_{stg} | -55 to +125 | °C |
| 6 | Soldering Temperature | T_{sol} | +260 (1) | °C |

NOTES:

- Duration 10s maximum and the same contact shall not be resoldered until 3 minutes have elapsed.

FIGURE 1 - PARAMETER DERATING INFORMATION

FIGURE 1(a) - WORKING VOLTAGE VERSUS ALTITUDE

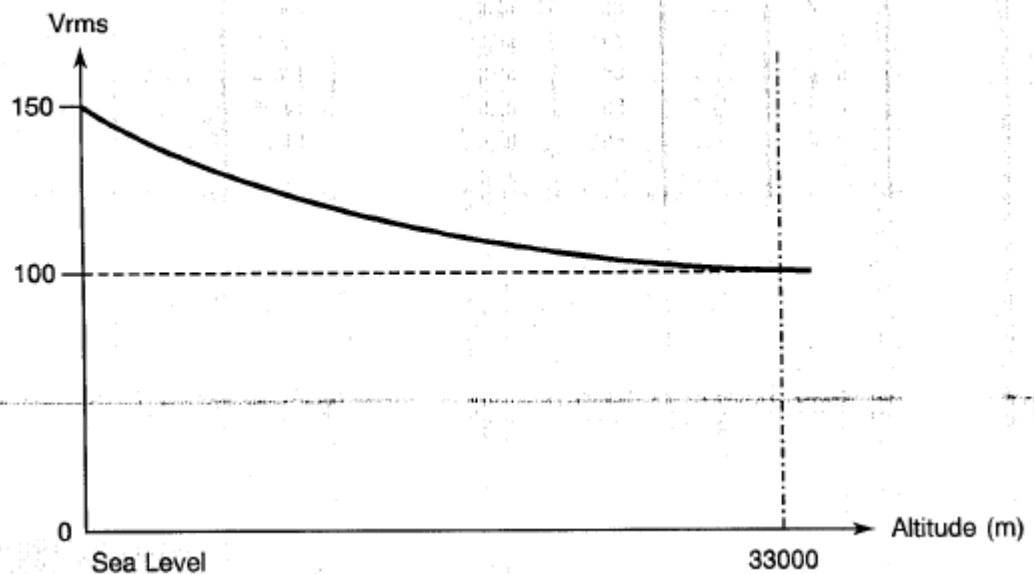
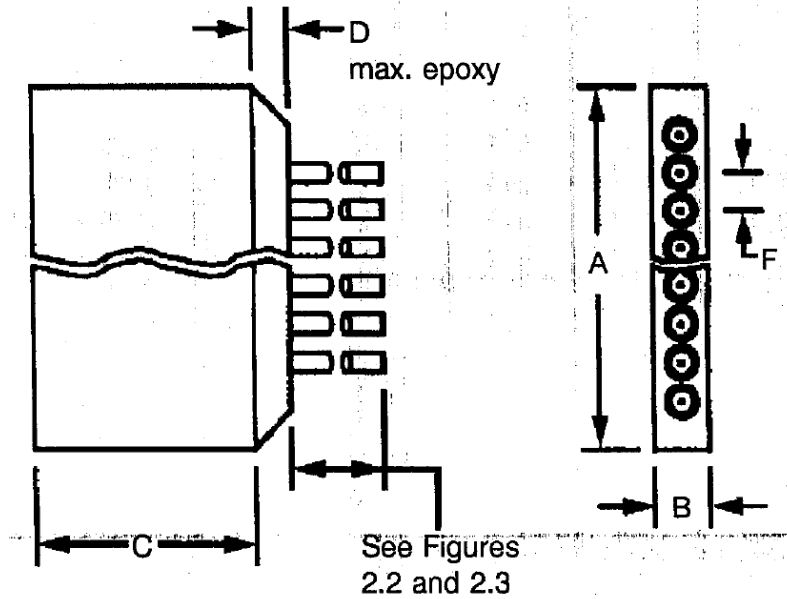

FIGURE 1(b) - MAXIMUM CURRENT VERSUS NUMBER OF CONTACTS

| Number of Contacts per Connector | Maximum Current per Contact (A) | |
|----------------------------------|----------------------------------|-------|
| | Wire Size | |
| | AWG26 and Uninsulated Solid Wire | AWG28 |
| 2 - 4 | 2 | 1.4 |
| 5 - 14 | 1.8 | 1.2 |
| 15 and over | 1.4 | 0.9 |

FIGURE 2 – PHYSICAL DIMENSIONS

FIGURE 2.1(a) - CONNECTORS PLUG - MALE CONTACTS



| Insert Size | A | | B | | C | | D | F |
|-------------|-------|-------|-----|------|------|------|------|---------|
| | Min | Max | Min | Max | Min | Max | Max | Typical |
| 5 | 6.47 | 7.23 | 1.9 | 2.16 | 7.06 | 7.32 | 3.18 | 1.27 |
| 6 | 7.75 | 8.51 | 1.9 | 2.16 | 7.06 | 7.32 | 3.18 | 1.27 |
| 7 | 9.02 | 9.78 | 1.9 | 2.16 | 7.06 | 7.32 | 3.18 | 1.27 |
| 8 | 10.29 | 11.05 | 1.9 | 2.16 | 7.06 | 7.32 | 3.18 | 1.27 |
| 9 | 11.56 | 12.32 | 1.9 | 2.16 | 7.06 | 7.32 | 3.18 | 1.27 |
| 10 | 12.82 | 13.58 | 1.9 | 2.16 | 7.06 | 7.32 | 3.18 | 1.27 |
| 11 | 14.1 | 14.86 | 1.9 | 2.16 | 7.06 | 7.32 | 3.18 | 1.27 |
| 12 | 15.37 | 16.13 | 1.9 | 2.16 | 7.06 | 7.32 | 3.18 | 1.27 |
| 13 | 16.64 | 17.4 | 1.9 | 2.16 | 7.06 | 7.32 | 3.18 | 1.27 |
| 14 | 17.91 | 18.67 | 1.9 | 2.16 | 7.06 | 7.32 | 3.18 | 1.27 |
| 15 | 19.18 | 20.04 | 1.9 | 2.16 | 7.06 | 7.32 | 3.18 | 1.27 |
| 16 | 20.45 | 21.21 | 1.9 | 2.16 | 7.06 | 7.32 | 3.18 | 1.27 |
| 17 | 21.72 | 22.48 | 1.9 | 2.16 | 7.06 | 7.32 | 3.18 | 1.27 |
| 18 | 22.99 | 23.75 | 1.9 | 2.16 | 7.06 | 7.32 | 3.18 | 1.27 |
| 19 | 24.26 | 25.02 | 1.9 | 2.16 | 7.06 | 7.32 | 3.18 | 1.27 |
| 20 | 25.53 | 26.29 | 1.9 | 2.16 | 7.06 | 7.32 | 3.18 | 1.27 |
| 21 | 26.8 | 27.56 | 1.9 | 2.16 | 7.06 | 7.32 | 3.18 | 1.27 |
| 22 | 28.07 | 28.83 | 1.9 | 2.16 | 7.06 | 7.32 | 3.18 | 1.27 |
| 23 | 29.34 | 30.1 | 1.9 | 2.16 | 7.06 | 7.32 | 3.18 | 1.27 |
| 24 | 30.61 | 31.47 | 1.9 | 2.16 | 7.06 | 7.32 | 3.18 | 1.27 |
| 25 | 31.88 | 32.64 | 1.9 | 2.16 | 7.06 | 7.32 | 3.18 | 1.27 |
| 26 | 33.15 | 33.91 | 1.9 | 2.16 | 7.06 | 7.32 | 3.18 | 1.27 |
| 27 | 34.42 | 35.18 | 1.9 | 2.16 | 7.06 | 7.32 | 3.18 | 1.27 |
| 28 | 35.69 | 46.45 | 1.9 | 2.16 | 7.06 | 7.32 | 3.18 | 1.27 |
| 29 | 36.96 | 37.72 | 1.9 | 2.16 | 7.06 | 7.32 | 3.18 | 1.27 |
| 30 | 38.23 | 38.99 | 1.9 | 2.16 | 7.06 | 7.32 | 3.18 | 1.27 |

| Insert Size | A | | B | | C | | D | F |
|-------------|-------|-------|-----|------|------|------|------|---------|
| | Min | Max | Min | Max | Min | Max | Max | Typical |
| 31 | 39.5 | 40.26 | 1.9 | 2.16 | 7.06 | 7.32 | 3.18 | 1.27 |
| 32 | 40.77 | 41.53 | 1.9 | 2.16 | 7.06 | 7.32 | 3.18 | 1.27 |
| 33 | 42.04 | 42.8 | 1.9 | 2.16 | 7.06 | 7.32 | 3.18 | 1.27 |
| 34 | 43.31 | 44.07 | 1.9 | 2.16 | 7.06 | 7.32 | 3.18 | 1.27 |
| 35 | 44.58 | 45.34 | 1.9 | 2.16 | 7.06 | 7.32 | 3.18 | 1.27 |
| 36 | 45.85 | 46.61 | 1.9 | 2.16 | 7.06 | 7.32 | 3.18 | 1.27 |
| 37 | 47.12 | 47.88 | 1.9 | 2.16 | 7.06 | 7.32 | 3.18 | 1.27 |
| 38 | 48.39 | 49.15 | 1.9 | 2.16 | 7.06 | 7.32 | 3.18 | 1.27 |
| 39 | 49.66 | 50.42 | 1.9 | 2.16 | 7.06 | 7.32 | 3.18 | 1.27 |
| 40 | 50.93 | 51.69 | 1.9 | 2.16 | 7.06 | 7.32 | 3.18 | 1.27 |
| 41 | 52.2 | 52.96 | 1.9 | 2.16 | 7.06 | 7.32 | 3.18 | 1.27 |
| 42 | 53.47 | 54.23 | 1.9 | 2.16 | 7.06 | 7.32 | 3.18 | 1.27 |
| 43 | 54.74 | 55.5 | 1.9 | 2.16 | 7.06 | 7.32 | 3.18 | 1.27 |
| 44 | 56.01 | 56.77 | 1.9 | 2.16 | 7.06 | 7.32 | 3.18 | 1.27 |
| 45 | 57.28 | 58.04 | 1.9 | 2.16 | 7.06 | 7.32 | 3.18 | 1.27 |
| 46 | 58.55 | 59.31 | 1.9 | 2.16 | 7.06 | 7.32 | 3.18 | 1.27 |
| 47 | 59.82 | 60.58 | 1.9 | 2.16 | 7.06 | 7.32 | 3.18 | 1.27 |
| 48 | 61.09 | 61.85 | 1.9 | 2.16 | 7.06 | 7.32 | 3.18 | 1.27 |
| 49 | 62.36 | 63.12 | 1.9 | 2.16 | 7.06 | 7.32 | 3.18 | 1.27 |
| 50 | 63.63 | 64.39 | 1.9 | 2.16 | 7.06 | 7.32 | 3.18 | 1.27 |

NOTES:

1. All dimensions are in millimetres.

FIGURE 2.1(b) - CONNECTORS RECEPTACLE - FEMALE CONTACT

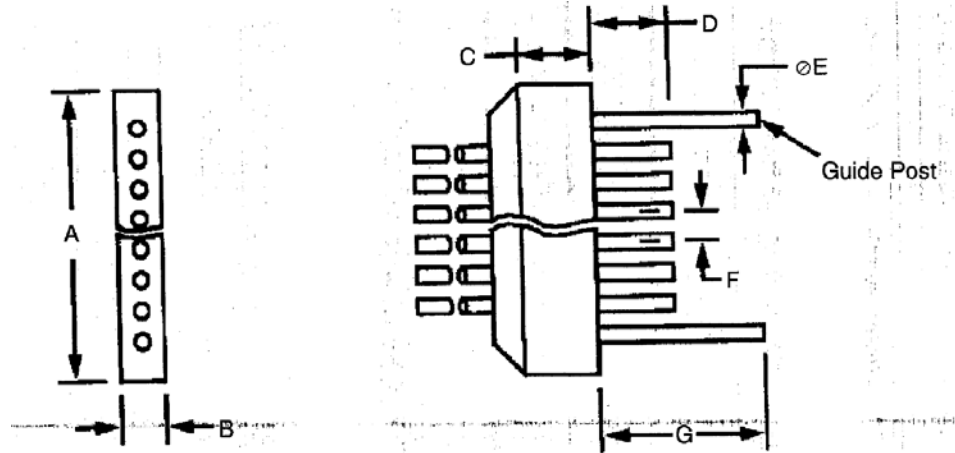

| Insert Size | A | | B | | C | | D | | ØE | | F | G | |
|-------------|-------|-------|-----|------|------|------|------|------|------|------|---------|------|------|
| | Min | Max | Min | Max | Min | Max | Min | Max | Min | Max | Typical | Min | Max |
| 5 | 6.47 | 7.23 | 1.9 | 2.16 | 2.41 | 2.67 | 3.07 | 3.33 | 0.78 | 0.84 | 1.27 | 4.83 | 5.33 |
| 6 | 7.75 | 8.51 | 1.9 | 2.16 | 2.41 | 2.67 | 3.07 | 3.33 | 0.78 | 0.84 | 1.27 | 4.83 | 5.33 |
| 7 | 9.02 | 9.78 | 1.9 | 2.16 | 2.41 | 2.67 | 3.07 | 3.33 | 0.78 | 0.84 | 1.27 | 4.83 | 5.33 |
| 8 | 10.29 | 11.05 | 1.9 | 2.16 | 2.41 | 2.67 | 3.07 | 3.33 | 0.78 | 0.84 | 1.27 | 4.83 | 5.33 |
| 9 | 11.56 | 12.32 | 1.9 | 2.16 | 2.41 | 2.67 | 3.07 | 3.33 | 0.78 | 0.84 | 1.27 | 4.83 | 5.33 |
| 10 | 12.82 | 13.58 | 1.9 | 2.16 | 2.41 | 2.67 | 3.07 | 3.33 | 0.78 | 0.84 | 1.27 | 4.83 | 5.33 |
| 11 | 14.1 | 14.86 | 1.9 | 2.16 | 2.41 | 2.67 | 3.07 | 3.33 | 0.78 | 0.84 | 1.27 | 4.83 | 5.33 |
| 12 | 15.37 | 16.13 | 1.9 | 2.16 | 2.41 | 2.67 | 3.07 | 3.33 | 0.78 | 0.84 | 1.27 | 4.83 | 5.33 |
| 13 | 16.64 | 17.4 | 1.9 | 2.16 | 2.41 | 2.67 | 3.07 | 3.33 | 0.78 | 0.84 | 1.27 | 4.83 | 5.33 |
| 14 | 17.91 | 18.67 | 1.9 | 2.16 | 2.41 | 2.67 | 3.07 | 3.33 | 0.78 | 0.84 | 1.27 | 4.83 | 5.33 |
| 15 | 19.18 | 20.04 | 1.9 | 2.16 | 2.41 | 2.67 | 3.07 | 3.33 | 0.78 | 0.84 | 1.27 | 4.83 | 5.33 |
| 16 | 20.45 | 21.21 | 1.9 | 2.16 | 2.41 | 2.67 | 3.07 | 3.33 | 0.78 | 0.84 | 1.27 | 4.83 | 5.33 |
| 17 | 21.72 | 22.48 | 1.9 | 2.16 | 2.41 | 2.67 | 3.07 | 3.33 | 0.78 | 0.84 | 1.27 | 4.83 | 5.33 |
| 18 | 22.99 | 23.75 | 1.9 | 2.16 | 2.41 | 2.67 | 3.07 | 3.33 | 0.78 | 0.84 | 1.27 | 4.83 | 5.33 |
| 19 | 24.26 | 25.02 | 1.9 | 2.16 | 2.41 | 2.67 | 3.07 | 3.33 | 0.78 | 0.84 | 1.27 | 4.83 | 5.33 |
| 20 | 25.53 | 26.29 | 1.9 | 2.16 | 2.41 | 2.67 | 3.07 | 3.33 | 0.78 | 0.84 | 1.27 | 4.83 | 5.33 |
| 21 | 26.8 | 27.56 | 1.9 | 2.16 | 2.41 | 2.67 | 3.07 | 3.33 | 0.78 | 0.84 | 1.27 | 4.83 | 5.33 |
| 22 | 28.07 | 28.83 | 1.9 | 2.16 | 2.41 | 2.67 | 3.07 | 3.33 | 0.78 | 0.84 | 1.27 | 4.83 | 5.33 |
| 23 | 29.34 | 30.1 | 1.9 | 2.16 | 2.41 | 2.67 | 3.07 | 3.33 | 0.78 | 0.84 | 1.27 | 4.83 | 5.33 |
| 24 | 30.61 | 31.47 | 1.9 | 2.16 | 2.41 | 2.67 | 3.07 | 3.33 | 0.78 | 0.84 | 1.27 | 4.83 | 5.33 |
| 25 | 31.88 | 32.64 | 1.9 | 2.16 | 2.41 | 2.67 | 3.07 | 3.33 | 0.78 | 0.84 | 1.27 | 4.83 | 5.33 |
| 26 | 33.15 | 33.91 | 1.9 | 2.16 | 2.41 | 2.67 | 3.07 | 3.33 | 0.78 | 0.84 | 1.27 | 4.83 | 5.33 |
| 27 | 34.42 | 35.18 | 1.9 | 2.16 | 2.41 | 2.67 | 3.07 | 3.33 | 0.78 | 0.84 | 1.27 | 4.83 | 5.33 |
| 28 | 35.69 | 46.45 | 1.9 | 2.16 | 2.41 | 2.67 | 3.07 | 3.33 | 0.78 | 0.84 | 1.27 | 4.83 | 5.33 |
| 29 | 36.96 | 37.72 | 1.9 | 2.16 | 2.41 | 2.67 | 3.07 | 3.33 | 0.78 | 0.84 | 1.27 | 4.83 | 5.33 |
| 30 | 38.23 | 38.99 | 1.9 | 2.16 | 2.41 | 2.67 | 3.07 | 3.33 | 0.78 | 0.84 | 1.27 | 4.83 | 5.33 |
| 31 | 39.5 | 40.26 | 1.9 | 2.16 | 2.41 | 2.67 | 3.07 | 3.33 | 0.78 | 0.84 | 1.27 | 4.83 | 5.33 |
| 32 | 40.77 | 41.53 | 1.9 | 2.16 | 2.41 | 2.67 | 3.07 | 3.33 | 0.78 | 0.84 | 1.27 | 4.83 | 5.33 |
| 33 | 42.04 | 42.8 | 1.9 | 2.16 | 2.41 | 2.67 | 3.07 | 3.33 | 0.78 | 0.84 | 1.27 | 4.83 | 5.33 |
| 34 | 43.31 | 44.07 | 1.9 | 2.16 | 2.41 | 2.67 | 3.07 | 3.33 | 0.78 | 0.84 | 1.27 | 4.83 | 5.33 |
| 35 | 44.58 | 45.34 | 1.9 | 2.16 | 2.41 | 2.67 | 3.07 | 3.33 | 0.78 | 0.84 | 1.27 | 4.83 | 5.33 |

| Insert Size | A | | B | | C | | D | | ØE | | F | G | |
|-------------|-------|-------|-----|------|------|------|------|------|------|------|---------|------|------|
| | Min | Max | Min | Max | Min | Max | Min | Max | Min | Max | Typical | Min | Max |
| 36 | 45.85 | 46.61 | 1.9 | 2.16 | 2.41 | 2.67 | 3.07 | 3.33 | 0.78 | 0.84 | 1.27 | 4.83 | 5.33 |
| 37 | 47.12 | 47.88 | 1.9 | 2.16 | 2.41 | 2.67 | 3.07 | 3.33 | 0.78 | 0.84 | 1.27 | 4.83 | 5.33 |
| 38 | 48.39 | 49.15 | 1.9 | 2.16 | 2.41 | 2.67 | 3.07 | 3.33 | 0.78 | 0.84 | 1.27 | 4.83 | 5.33 |
| 39 | 49.66 | 50.42 | 1.9 | 2.16 | 2.41 | 2.67 | 3.07 | 3.33 | 0.78 | 0.84 | 1.27 | 4.83 | 5.33 |
| 40 | 50.93 | 51.69 | 1.9 | 2.16 | 2.41 | 2.67 | 3.07 | 3.33 | 0.78 | 0.84 | 1.27 | 4.83 | 5.33 |
| 41 | 52.2 | 52.96 | 1.9 | 2.16 | 2.41 | 2.67 | 3.07 | 3.33 | 0.78 | 0.84 | 1.27 | 4.83 | 5.33 |
| 42 | 53.47 | 54.23 | 1.9 | 2.16 | 2.41 | 2.67 | 3.07 | 3.33 | 0.78 | 0.84 | 1.27 | 4.83 | 5.33 |
| 43 | 54.74 | 55.5 | 1.9 | 2.16 | 2.41 | 2.67 | 3.07 | 3.33 | 0.78 | 0.84 | 1.27 | 4.83 | 5.33 |
| 44 | 56.01 | 56.77 | 1.9 | 2.16 | 2.41 | 2.67 | 3.07 | 3.33 | 0.78 | 0.84 | 1.27 | 4.83 | 5.33 |
| 45 | 57.28 | 58.04 | 1.9 | 2.16 | 2.41 | 2.67 | 3.07 | 3.33 | 0.78 | 0.84 | 1.27 | 4.83 | 5.33 |
| 46 | 58.55 | 59.31 | 1.9 | 2.16 | 2.41 | 2.67 | 3.07 | 3.33 | 0.78 | 0.84 | 1.27 | 4.83 | 5.33 |
| 47 | 59.82 | 60.58 | 1.9 | 2.16 | 2.41 | 2.67 | 3.07 | 3.33 | 0.78 | 0.84 | 1.27 | 4.83 | 5.33 |
| 48 | 61.09 | 61.85 | 1.9 | 2.16 | 2.41 | 2.67 | 3.07 | 3.33 | 0.78 | 0.84 | 1.27 | 4.83 | 5.33 |
| 49 | 62.36 | 63.12 | 1.9 | 2.16 | 2.41 | 2.67 | 3.07 | 3.33 | 0.78 | 0.84 | 1.27 | 4.83 | 5.33 |
| 50 | 63.63 | 64.39 | 1.9 | 2.16 | 2.41 | 2.67 | 3.07 | 3.33 | 0.78 | 0.84 | 1.27 | 4.83 | 5.33 |

NOTES:

1. All dimensions are in millimetres.

FIGURE 2.2 - UNINSULATED SOLID WIRES

FR116 – Plug (pin contacts)

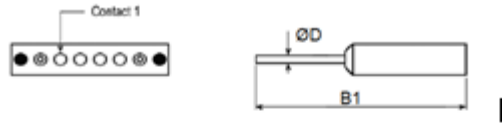

FR116 – Receptacle (socket contact)

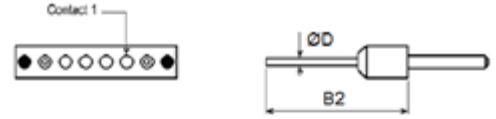

FR116 C – Plug (pin contacts)

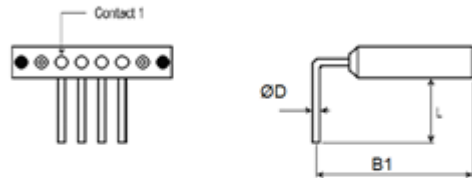

FR116 C – Receptacle (socket contact)

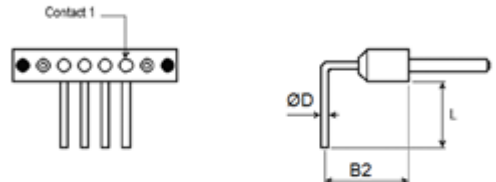

FR116 D1 – Plug (pin contacts)

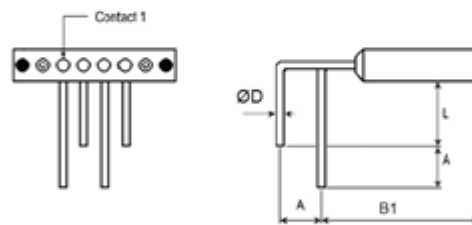

FR116 D1 – Receptacle (socket contact)

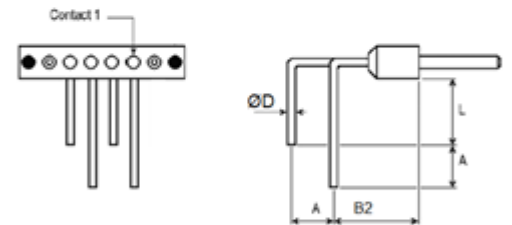

FR116 D2 – Plug (pin contacts)

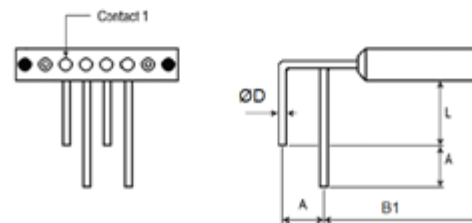

FR116 D2 – Receptacle (socket contact)

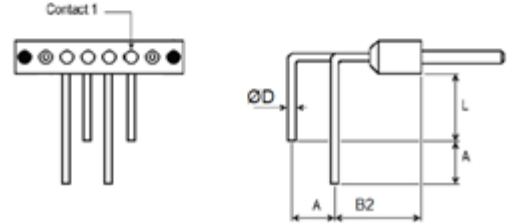

| Terminations Code | FR116 | FR116 C | FR116 D1 | FR116 D2 |
|-----------------------|----------|-----------|-----------|-----------|
| Wire Size (AWG) | 25 | 25 | 25 | 25 |
| Max Diameter 'D' (mm) | 0.51 | 0.51 | 0.51 | 0.51 |
| Min Diameter 'D' (mm) | 0.4 | 0.4 | 0.4 | 0.4 |
| Max Weight (g/m) | 1.6 | 1.6 | 1.6 | 1.6 |
| L (mm) | - | 6 | 6 | 6 |
| A (mm) | - | - | 2.54 Typ. | 2.54 Typ. |
| B1 (mm) | 32.6 min | 9.73 Typ. | 9.73 Typ. | 9.73 Typ. |
| B2 (mm) | 28 min | 5.08 Typ. | 5.08 Typ. | 5.08 Typ. |

FIGURE 2.3 - INSULATED WIRES



Minimum length and maximum wire weight: see Para. 4.5.4.3.

FIGURE 2.4 – SOLDER BUCKET

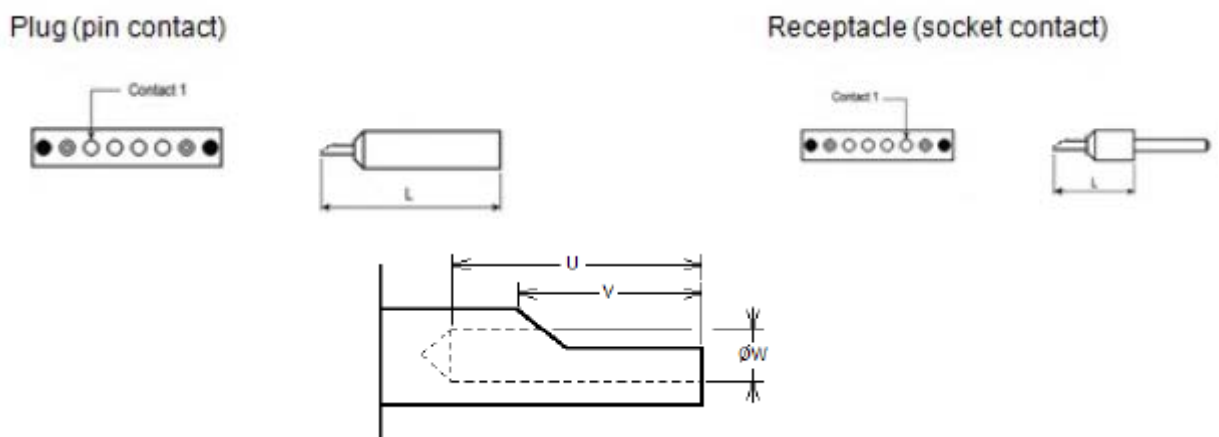

| | L | | U | | V | | $\varnothing W$ | |
|------------|------|-----|-----|-----|-----|------|-----------------|-----|
| | Max | Min | Min | Max | Min | Max | Min | Max |
| Plug | 11.2 | 1.8 | 2.2 | 1.5 | 1.8 | 0.55 | 0.61 | |
| Receptacle | 6.55 | 2 | 2.4 | 1.5 | 1.8 | 0.55 | 0.61 | |

NOTES

1. All dimensions are in millimetres.
2. Maximum wire accepted in the solder cup: AWG 26.

FIGURE 2.5 – LATCHING

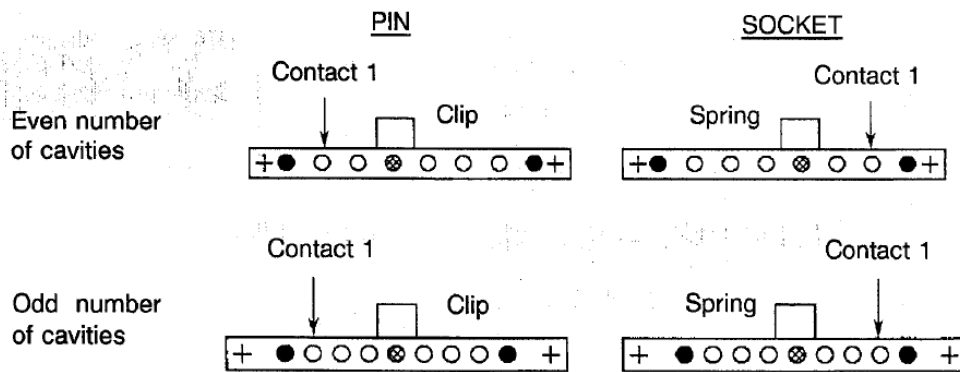
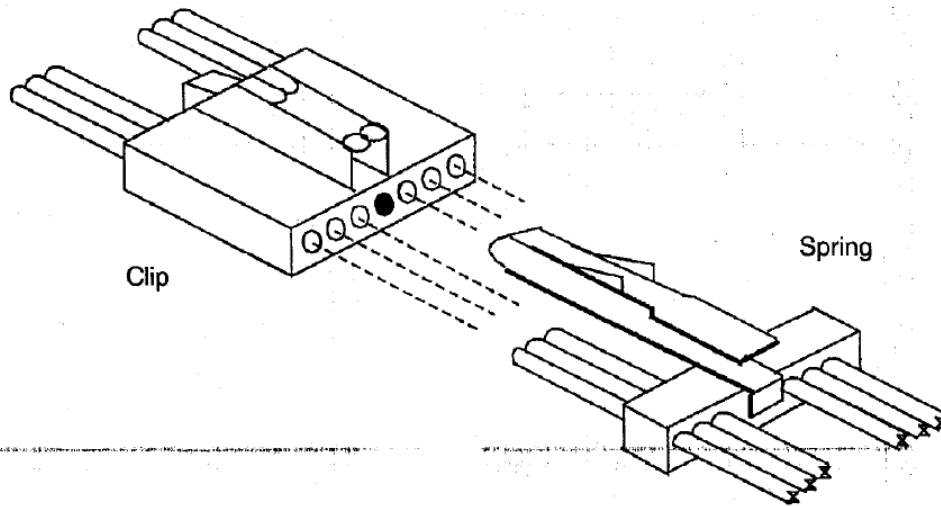

(Seen from contact side)

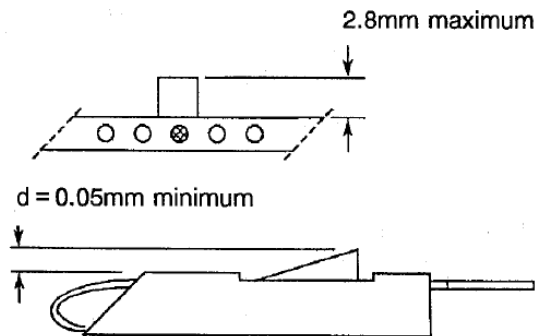

Latching force = 10N maximum

FIGURE 2.6 - CONTACT POSITION

FIGURE 2.6.1 - MOUNTING CONDITION

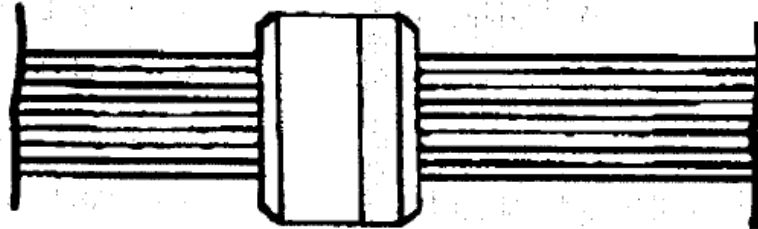

FIGURE 2.6.2 - PLUG MALE CONTACT

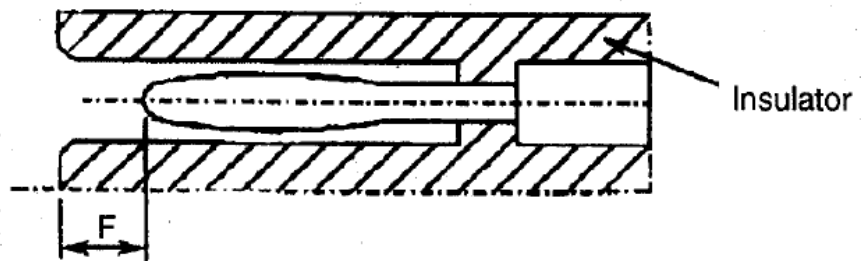
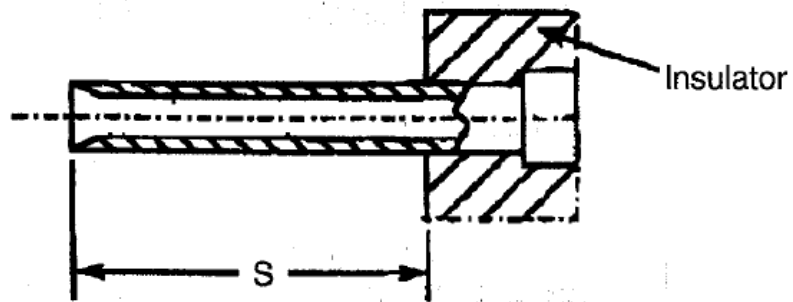

FIGURE 2.6.3 - RECEPTACLE FEMALE CONTACT



| F | | S | |
|------|------|------|------|
| Min | Max | Min | Max |
| 0.25 | 0.91 | 3.07 | 3.33 |

NOTES

1. All dimensions are in millimetres.

3 TERMS, DEFINITIONS, ABBREVIATIONS, SYMBOLS AND UNITS

For the purpose of this specification, the terms, definitions, abbreviations, symbols and units specified in ESCC Basic Specification No. 21300 shall apply.

4 REQUIREMENTS

4.1 GENERAL

The complete requirements for procurement of the connectors specified herein are stated in this specification and ESCC Generic Specification No. 3401. Deviations from the Generic Specification, applicable to this specification only, are listed in Para. 4.2.

Deviations from the applicable Generic Specification and this Detail Specification, formally agreed with specific Manufacturers on the basis that the alternative requirements are equivalent to the ESCC requirements and do not affect the components' reliability, are listed in the appendices attached to this specification.

4.2 DEVIATIONS FROM GENERIC SPECIFICATION

4.2.1 Deviations from Special In-process Controls

- (a) Para. 9.15, Joint Strength: The contacts shall be crimped to insulated stranded wire AWG26 and AWG28 and to uninsulated solid wire AWG25. The value of failure shall be recorded together with the information as to whether the failure was "pull-out", "break in crimp" or "break in wire". The minimum tensile strength shall be as follows.

| Wire | Male And Female Contacts | | |
|----------------------|--------------------------|-------|---------------------------|
| | AWG26 | AWG28 | AWG25 - Solid Uninsulated |
| Tensile Strength (N) | 22 | 13 | 22 |

4.2.2 Deviations from Final Production Tests (Chart II)

- (a) Para. 9.1.1.4, Mated Shell Conductivity: Not applicable.
- (b) Para. 9.3, Contact Retainer Test: Not applicable.
- (c) Para. 9.4, Contact Capability: This test shall be performed on male contacts. For details see Para. 4.3.3 of this specification.
- (d) Para. 9.5, Magnetism Level: Not applicable.

4.2.3 Deviations from Burn-in and Electrical Measurements (Chart III)

Not applicable.

4.2.4 Deviations from Qualification Tests (Chart IV)

- (a) Para. 9.1.1.4, Mated Shell Conductivity: Not applicable.
- (b) Para. 9.9, Seal Test: Not applicable.
- (c) Para. 9.15, Joint Strength: Not applicable.
- (d) Para. 9.17, Contact Retention (In Insert): Not applicable with male contact.
- (e) Para. 9.27, Maintenance Ageing: Not applicable.
- (f) Para. 9.29, Oversize Pin Exclusion: Not applicable.
- (g) Para. 9.30, Probe Damage: Not applicable.
- (h) Latching shall be performed as specified in Para. 4.3.13 of this specification.
- (i) Para. 9.31, Solderability: Only applicable to FR164 termination.

4.2.5 Deviations from Lot Acceptance Tests (Chart V)

- (a) Para. 9.1.1.4, Mated Shell Conductivity: Not applicable.
- (b) Para. 9.9, Seal Test: Not applicable.
- (c) Para. 9.15, Joint Strength: Not applicable.
- (d) Para. 9.17, Contact Retention (In Insert): Not applicable with male contact.
- (e) Para. 9.27, Maintenance Ageing: Not applicable.
- (f) Para. 9.29, Oversize Pin Exclusion: Not applicable.
- (g) Para. 9.30, Probe Damage: Not applicable.
- (h) Latching shall be performed as specified in Para. 4.3.13 of this specification.

4.3 MECHANICAL REQUIREMENTS

4.3.1 Dimension Check

The dimensions of the connectors specified herein shall be verified in accordance with the requirements set out in Para. 9.6 of ESCC Generic Specification No. 3401 and shall conform to those shown in Figure 2 of this specification. Only the underlined dimensions shall be checked during procurement.

4.3.2 Weight

The maximum weight of the connectors specified herein shall be calculated on the basis of, and be in accordance with, the values given in Table 1(b) and in Figures 2.2 and 2.3 of this specification.

4.3.3 Contact Capability

For the purpose of this test, the pick-up and drop weights shall be as follows.

| Measurements | Pick-Up Weight | Drop Weight |
|-------------------------------|----------------|---------------|
| Weight (g) | 14 | 170 |
| Inner Gauge Diameter (mm) (1) | 0.582 - 0.587 | 0.559 - 0.564 |
| Insertion Depth (mm) | 1.5 | 1.5 |

NOTES:

1. See Figure 3 for ØA.

4.3.4 Contact Retention (In Insert)

Contact retention within the insert shall be 22.25N. There shall be no displacement of the contact. Not applicable to male contacts.

4.3.5 Mating and Unmating Forces

The forces applied for mating and unmating of the connectors shall conform to the values specified in Table 1(c).

4.3.6 Insert Retention (In Shell)

Not applicable.

4.3.7 Jackscrew Retention

Not applicable.

4.3.8 Contact Insertion and Withdrawal Forces

Not applicable.

4.3.9 Engagement and Separation Forces

The contact engagement and separation forces of the male contacts shall be tested to a depth of 1.5mm with the applicable test gauge fixture specified in Figure 3 of this specification, and shall not exceed the values of the table hereunder.

| Measurements | Inner Diameter (mm) | | Separation Force Min (N) | Engagement Force Max (N) |
|-------------------|---------------------|-------|--------------------------|--------------------------|
| | Min | Max | | |
| Max Gauge Fixture | 0.559 | 0.564 | - | 1.667 |
| Min Gauge Fixture | 0.582 | 0.587 | 0.137 | - |

4.3.10 Oversize Pin Exclusion

Not applicable.

4.3.11 Probe Damage

Not applicable.

4.3.12 Solderability

Only applicable on FR164 termination. Size A soldering iron shall be used.

4.3.13 Latching

Unlocking is achieved by applying a force of 3N minimum, perpendicular to the connector at the end of the spring.

The endurance test (10 cycles of mating/unmating) shall be performed with the force, applied at the end of the spring, necessary to achieve a travel of 1mm (unlocking travel = 0.5mm, total travel = 1.15mm). The requirement after the endurance test is that dimension d = 0.05mm, minimum.

4.4 MATERIALS AND FINISHES

The materials and finishes shall be as specified herein. Where a definite material is not specified, a material which will enable the connectors specified herein to meet the performance requirements of this specification shall be used. Acceptance or approval of any constituent material does not guarantee acceptance of the finished product.

4.4.1 Inserts

Inserts shall be made of glass-fibre filled diallylphthalate resin or a suitable thermoplastic material.

4.4.2 Contacts

4.4.2.1 *Female Contacts*

The contact body material and finish shall either be copper alloy with an underplate of 1µm minimum of copper to SAE-AMS 2418, gold plated with 1.27µm minimum of gold Type 2, Grade C of MIL-DTL-45204. Measurement of thickness shall be performed at a distance of 1.5mm from the engagement end.

4.4.2.2 *Male Contacts*

The contact body and the bundle material and finish shall either be copper alloy with an underplate of 1µm minimum of copper to SAE-AMS 2418, gold plated with 1.27µm minimum of gold, Type 2, Grade C of MIL-DTL-45204. Measurement of thickness shall be performed at a distance of 1.5mm from the engagement end.

4.4.3 Guide Posts

Guide posts shall be made from passivated stainless steel, Type 303.

4.4.4 Latching

Clip and spring shall be made of passivated stainless steel.

4.4.5 Insulated Wires

Wire materials and finishes shall be in accordance with the requirements specified in Para. 4.4 of ESCC Detail Specification No. [3901/013](#).

4.4.6 Uninsulated Solid Wires

Uninsulated solid wire material and finish shall either be copper alloy in accordance with Type 'S' as specified in QQ-W-343, gold-plated in accordance with Class ØØ, Grade C or D, as specified in MIL-DTL-45204.

4.4.7 Rear Potting

Rear potting shall be made of epoxy resin.

4.5 MARKING

4.5.1 General

The marking of components delivered to this specification shall be in accordance with the requirements of ESCC Basic Specification No. [21700](#) and the following paragraphs. When the component is too small to accommodate all of the marking specified, as much as space permits shall be marked and the marking information, in full, shall accompany the component in its primary package.

The information to be marked and the order of precedence, shall be as follows:

- (a) The ESCC Component Number.
- (b) Characteristics.
- (c) Traceability Information.

4.5.2 Contact Identification

Not applicable.

4.5.3 The ESCC Component Number

ESCC Component Number shall be constituted and marked as follows:

Example: 340103101B

- Detail Specification Number: 3401031
- Type Variant (see Table 1(a)): 01
- Testing level: B

4.5.4 Characteristics

The characteristics to be marked in the following order of precedence are:

- (a) Insert size
- (b) Contact Type
- (c) Termination Type
- (d) Polarisation (optional)

The information shall be constituted and marked as follows:

Example: 50P FR112 *

- Insert Size: 50
- Contact Type: P
- Termination Type: FR112
- Polarisation: *

4.5.4.1 *Insert Size*

The Insert size shall be designated by 2 digits representing the number of available cavities plus 4 additional cavities plus (see Para. 1.2):

- (a) 4 additional cavities for Variant 01.
The specified numbers range from 05 through to 50 maximum.
- (b) 5 additional cavities for Variant 02.
The specified numbers range from 06 through to 50 maximum.

4.5.4.2 *Contact Types*

Contact types shall be indicated by the following code letters.

| Code Letter | Contact Type |
|-------------|--------------|
| P | Male |
| S | Female |

4.5.4.3 *Termination Types*

Termination types define length and weight of insulated wire or uninsulated solid wire according to Figures 2.2 and 2.3 or solder type according to Figure 2.4 as follows:

| Code | Type (see Figure 2) | Min Length (mm) | Max. Weight |
|----------|---|-----------------|------------------------------|
| FR112 | Wire AWG 26 | 508 | See 3901/013 |
| FR113 | Wire AWG 26 | 914 | See 3901/013 |
| FR114 | Wire AWG 28 | 508 | See 3901/013 |
| FR115 | Wire AWG 28 | 914 | See 3901/013 |
| FR116 | Uninsulated Solid Wire | See Figure 2.2 | See Figure 2.2 |
| FR116 C | Uninsulated Solid 90°C Formed Wire | See Figure 2.2 | See Figure 2.2 |
| FR116 D1 | Uninsulated Solid 90°C Formed Wire (Long Terminations on Odd Contacts) | See Figure 2.2 | See Figure 2.2 |
| FR116 D2 | Uninsulated Solid 90°C Formed Wire (Long Terminations on Even Contacts) | See Figure 2.2 | See Figure 2.2 |
| FR164 | Solder Bucket | N/A | See Table 1(b) |

4.5.4.4 Polarisation

The marking of the cavity number used for the polarisation is optional and is used only in case the Orderer wishes to specify his own polarisation means by epoxy-filled cavities or guide posts (see Para. 1.2). There is no mandatory requirement for this part of the marking.

4.5.5 Traceability Information

Traceability information shall be marked in accordance with the requirements of ESCC Basic Specification No. 21700.

4.6 ELECTRICAL MEASUREMENTS

4.6.1 Electrical Measurements at Room Temperature

The parameters to be measured in respect of electrical characteristics are scheduled in Table 2. Unless otherwise specified, these measurements shall be performed at $T_{amb} = +22 \pm 3^{\circ}C$.

4.6.2 Electrical Measurements at High and Low Temperatures

Not applicable.

4.6.3 Circuits for Electrical Measurements (Figure 4)

Not applicable.

4.7 BURN-IN AND ELECTRICAL MEASUREMENTS

Not applicable.

TABLE 2 - ELECTRICAL MEASUREMENTS AT ROOM TEMPERATURE

| No. | Characteristics | Symbol | ESCC 3401 Test Method | Test Conditions | Limits | | Unit |
|-----|--|---------------------|-----------------------|-----------------|--------|-----|------|
| | | | | | Min | Max | |
| 1 | Insulation Resistance | R _i | Para. 9.1.1.1 | Para. 9.1.1.1 | 5000 | - | MΩ |
| 2 | Voltage Proof Leakage Current | I _L | Para. 9.1.1.2 | 600Vrms | - | 2 | mA |
| 4 | Contact Resistance (Low Level Current) | R _{cl} max | Para. 9.1.1.3 | Para. 9.1.1.3 | - | 6 | mΩ |
| 5 | Contact Resistance (Rated Current) | R _{cr} max | Para. 9.1.1.3 | Table 1(d) | - | 5 | mΩ |

TABLES 3, 4, 5

Not applicable.

FIGURE 3 – GAUGE FIXTURE

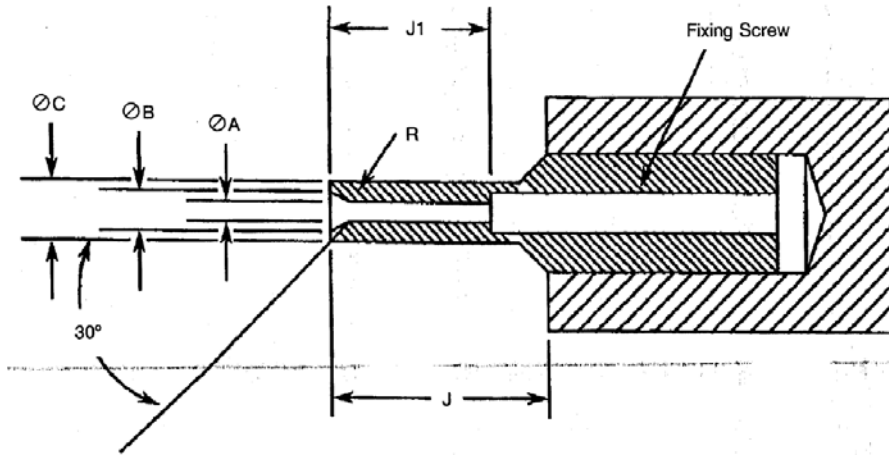

Maximum Gauge

| Weight (g) | 170 | | Remarks |
|----------------|--------|-------|---------|
| Dimension (mm) | Limits | | |
| | Min | Max | |
| ØA | 0.559 | 0.564 | - |
| ØB | 0.749 | 0.775 | - |
| ØC | 0.813 | 0.825 | - |
| J | 4 | - | - |
| J1 | 3.13 | 3.23 | - |
| R | 0.381 | 0.483 | Note 1 |

Minimum Gauge

| Weight (g) | 14 | | Remarks |
|----------------|--------|-------|---------|
| Dimension (mm) | Limits | | |
| | Min | Max | |
| ØA | 0.582 | 0.587 | - |
| ØB | 0.749 | 0.775 | - |
| ØC | 0.813 | 0.825 | - |
| J | 4 | - | - |
| J1 | 3.13 | 3.23 | - |
| R | 0.381 | 0.483 | Note 1 |

NOTES

1. Radius 'R' must be tangent to entry chamfer and ØA.

ØA and entry chamfer must be polished to. 

4.8 ENVIRONMENTAL AND ENDURANCE TESTS (CHARTS IV AND V OF ESCC GENERIC SPECIFICATION No. 3401)

4.8.1 Measurements and Inspections on Completion of Environmental Tests

The parameters to be measured and inspections to be performed on completion of environmental testing shall be those specified in Table 6. Unless otherwise stated, the measurements shall be performed at $T_{amb} = +22 \pm 3^{\circ}\text{C}$.

4.8.2 Measurements and Inspections at Intermediate Points during Endurance Tests

Not applicable.

4.8.3 Measurements and Inspections on Completion of Endurance Tests

The parameters to be measured and inspections to be performed on completion of endurance tests shall be those specified in Table 6. Unless otherwise stated, the measurements shall be performed at $T_{amb} = +22 \pm 3^{\circ}\text{C}$.

4.8.4 Conditions for Operating Life Test (Part of Endurance Testing)

Not applicable.

4.8.5 Electrical Circuits for Operating Life Test (Figure 5)

Not applicable.

4.8.6 Conditions for High Temperature Storage Test (Part of Endurance Testing)

The requirements for the high temperature storage test are specified in Section 9 of ESCC Generic Specification No. 3401. The temperature to be applied shall be the maximum storage temperature specified in Table 1(b) of this specification.

TABLE 6 – MEASUREMENTS AND INSPECTIONS ON COMPLETION OF ENVIRONMENTAL AND ENDURANCE TESTING

| No. | ESCC Generic Spec. No. 3401 | | Measurements and Inspections | | Symbol | Limits | | Unit |
|-----|---------------------------------------|---|--|----------------|--------|----------------|-----|------|
| | Environmental and Endurance Tests (1) | Test Method and Conditions | Identification | Conditions | | Min | Max | |
| 01 | Seal Test | Para. 9.9 | ESCC 3401 Para. 9.9 | - | - | Not applicable | | |
| 02 | Wiring | Para. 9.10 and Table 1(d) of this specification | Low Level Contact Resistance | Table 2 Item 4 | Rcl | Table 2 Item 4 | | |
| 03 | Vibration | Para. 9.11 | Final Measurements Full Engagement Visual Examination | - | - | - | - | |
| 04 | Shock or Bump | Para. 9.12 | Full Engagement Visual Examination | - | - | - | - | |

| No. | ESCC Generic Spec. No. 3401 | | Measurements and Inspections | | Symbol | Limits | | Unit |
|-----|---|-----------------------------------|--|---|----------------------|----------------------------------|---------------------------|------|
| | Environmental and Endurance Tests (1) | Test Method and Conditions | Identification | Conditions | | Min | Max | |
| 05 | Climatic Sequence | Para. 9.13 | Dry Heat Insulation Resistance | At High Temperature Table 2 Item 1 | Ri | 10 | - | MΩ |
| | | | Low Air Pressure Voltage Proof Leakage Current | Figure 1 | I _L | ESCC 3401 Para. 9.13.5 | | - |
| | | | Damp Heat Insulation Resistance | Immediately after test Table 2 Item 1 | Ri | 100 | - | MΩ |
| | | | Final Measurements External Visual Inspection | After 1-24 hrs Recovery ESCC 3401 Para. 9.7 | - | ESCC 3401 Para. 9.7 | | |
| | | | Insulation Resistance Voltage Proof Leakage Current | Table 2 Item 1 Table 2 Item 2 | Ri I _L | Table 2 Item 1 Table 2 Item 2 | | |
| 06 | Plating Thickness | Para. 9.14 | Thickness | - | - | Para. 4.4.2 of this spec. | | |
| 07 | Joint Strength (N/A to solder contacts) | Para. 9.15 | ESCC 3401 Para. 9.15 | - | - | Not applicable | | |
| 08 | Rapid Change of Temperature | Para. 9.16 | Visual Examination | - | - | - | - | |
| | | | Insulation Resistance Voltage Proof Leakage Current | Table 2 Item 1 Table 2 Item 2 | Ri I _L | Table 2 Item 1 Table 2 Item 2 | | |
| 09 | Contact Retention (in Insert) | Para. 9.17 & Para. 4.3.4 of spec. | Contact Displacement | Not applicable for male contacts | - | ESCC 3401 Para. 9.17 | | |
| 10 | Endurance | Para. 9.18 | Initial Measurements Mating/Unmating Forces | - | F | Para. 4.3.5 of this spec. | | |
| | | | Low Level Contact Resistance | Table 2 Item 4 | Rcl | Record Values | | |
| | | | Final Measurements Visual Examination | - | - | - | - | |
| | | | Mating/Unmating Forces Low Level Contact Resistance Drift | - Table 2 Item 4 | F ΔRcl | - 3 | Para. 4.3.5 of this spec. | mΩ |
| | | | Insulation Resistance Voltage Proof Leakage Current | Table 2 Item 1 Table 2 Item 2 | Ri I _L | Table 2 Item 1 Table 2 Item 2 | | |
| 11 | Permanence of Marking | Para. 9.19 | - | - | - | - | | |
| 12 | Mating/Unmating Forces | Para. 9.20 | Force | - | F | Para. 4.3.5 of this spec. | | |

| No. | ESCC Generic Spec. No. 3401 | | Measurements and Inspections | | Symbol | Limits | | Unit |
|-----|---------------------------------------|---|---|---|---|--|-----|------|
| | Environmental and Endurance Tests (1) | Test Method and Conditions | Identification | Conditions | | Min | Max | |
| 13 | High Temperature Storage | Para. 9.21 | Initial Measurements Low Level Contact Resistance Final Measurements Visual Examination Mating/Unmating Forces Low Level Contact Resistance Drift Rated Current Contact Resistance Insulation Resistance Voltage Proof Leakage Current Contact Retention (In Insert) | Table 2 Item 4 - - Table 2 Item 4 Table 2 Item 5 Table 2 Item 1 Table 2 Item 2 Para. 4.3.4 of this spec. | Rcl - F ΔRcl Rcr Ri I _L - | Record Values - Para. 4.3.5 of this spec. - 3 Table 2 Item 5 Table 2 Item 1 Table 2 Item 2 ESCC 3401 Para. 9.17 | m∅ | |
| 14 | Corrosion | Para. 9.22 | Visual Examination | - | - | - | - | |
| 15 | Insert Retention (In Shell) | Para. 9.23 & Para. 4.3.6 of this spec. | Visual Examination | - | - | Not applicable | | |
| 16 | Jackscrew Retention | Para. 9.24 & Para. 4.3.7 of this spec. | Visual Examination | - | - | Not applicable | | |
| 17 | High Temperature Measurements | Para. 9.25 | Insulation Resistance | Table 2 Item 1 | Ri | 5000 | - | MΩ |
| 18 | Overload Test | Para. 9.26 | Internal Temperature Rated Current Contact Resistance Insulation Resistance Voltage Proof Leakage Current | - Table 2 Item 5 Table 2 Item 1 Table 2 Item 2 | T Rcr Ri I _L | - +100 Table 2 Item 5 Table 2 Item 1 Table 2 Item 2 | °C | |
| 19 | Maintenance Ageing | Para. 9.27 & Paras. 4.2.4 and 4.2.5 of this spec. | Visual Examination Contact Retention (In Insert) | - | - | Not applicable Not applicable | | |
| 20 | Engagement/Separation Forces | Para. 9.28 & Para. 4.3.9 of this spec. | Force | - | F | Para. 4.3.9 of this spec. | | |
| 21 | Oversize Pin Exclusion | Para. 9.29 & Para. 4.3.10 of this spec. | - | - | - | Not applicable | | |
| 22 | Probe Damage | Para. 9.30 & Para. 4.3.11 of this spec. | Contact Separation Force | - | - | Not applicable | | |
| 23 | Solderability | Para. 9.31 & Para. 4.3.12 of this spec. | - | - | - | ESCC 3401 Para. 9.31 | | |

NOTES

1. The tests in this Table refer to either Chart IV or V and shall be used as applicable.

APPENDIX A**AGREED DEVIATIONS FOR C&K COMPONENTS (F)**

| ITEMS AFFECTED | DESCRIPTION OF DEVIATIONS |
|---|--|
| Paras. 4.2.2, Deviations from Final Production Tests (Chart II) | Para. 9.2, Mating Verification may be omitted if proper mating has already been verified by use of the dedicated electrical test equipment as defined in the C&K PID. |
| | Para. 9.4, Contact Capability: 100% Contact Capability Test may be omitted provided that a 100% visual inspection of the contacts is performed on each batch submitted to tests defined in the C&K PID requirements. |