



**CAPACITORS, FIXED, CERAMIC DIELECTRIC,
TYPE I, HIGH VOLTAGE, 1kV TO 5kV**

BASED ON TYPES VR, CV AND CH

ESCC Detail Specification No. 3001/033

Issue 5	November 2017
---------	---------------



LEGAL DISCLAIMER AND COPYRIGHT

European Space Agency, Copyright © 2017. All rights reserved.

The European Space Agency disclaims any liability or responsibility, to any person or entity, with respect to any loss or damage caused, or alleged to be caused, directly or indirectly by the use and application of this ESCC publication.

This publication, without prior the permission of the European Space Agency and provided that it is not used for a commercial purpose, may be:

- copied in whole, in any medium, without alteration or modification.
- copied in part, in any medium, provided that the ESCC document identification, comprising the ESCC symbol, document number and document issue, is removed.

DOCUMENTATION CHANGE NOTICE

(Refer to <https://escies.org> for ESCC DCR content)

DCR No.	CHANGE DESCRIPTION
1028	Specification updated to incorporate changes per DCR.

TABLE OF CONTENTS

1	GENERAL	5
1.1	SCOPE	5
1.2	APPLICABLE DOCUMENTS	5
1.3	TERMS, DEFINITIONS, ABBREVIATIONS, SYMBOLS AND UNITS	5
1.4	THE ESCC COMPONENT NUMBER AND COMPONENT TYPE VARIANTS	5
1.4.1	The ESCC Component Number	5
1.4.2	Component Type Variants and Range of Components	7
1.5	MAXIMUM RATINGS	8
1.6	PHYSICAL DIMENSIONS	9
1.6.1	Case Type VR with Radial Leads	9
1.6.2	Case Type CV with Radial Leads	10
1.6.3	Case Type CH with Straight DIL Leads	11
1.6.4	Case Type CH with L DIL Leads	12
1.7	FUNCTIONAL DIAGRAM	12
2	REQUIREMENTS	13
2.1	GENERAL	13
2.1.1	Deviations from the Generic Specification	13
2.2	MARKING	13
2.3	ROBUSTNESS OF TERMINATIONS	14
2.4	ELECTRICAL MEASUREMENTS AT ROOM, HIGH AND LOW TEMPERATURES	15
2.4.1	Room Temperature Electrical Measurements	15
2.4.2	High and Low Temperatures Electrical Measurements	16
2.5	INTERMEDIATE AND END-POINT ELECTRICAL MEASUREMENTS	17
2.6	BURN-IN	19
	APPENDIX A	20

1 GENERAL

1.1 SCOPE

This specification details the ratings, physical and electrical characteristics, and test and inspection data for the component type variants and/or the range of components specified below. It supplements the requirements of, and shall be read in conjunction with, the ESCC Generic Specification listed under Applicable Documents.

1.2 APPLICABLE DOCUMENTS

The following documents form part of this specification and shall be read in conjunction with it:

- (a) ESCC Generic Specification No. [3001](#).

1.3 TERMS, DEFINITIONS, ABBREVIATIONS, SYMBOLS AND UNITS

For the purpose of this specification, the terms, definitions, abbreviations, symbols and units specified in ESCC Basic Specification No. [21300](#) shall apply.

1.4 THE ESCC COMPONENT NUMBER AND COMPONENT TYPE VARIANTS

1.4.1 The ESCC Component Number

The ESCC Component Number shall be constituted as follows:

Example: 300103301470K1R

- Detail Specification Reference: 3001033
- Component Type Variant Number: 01 (as required)
- Characteristic code: Capacitance Value (47pF): 470 (as required)
- Characteristic code: Capacitance Tolerance ($\pm 10\%$): K (as required)
- Characteristic code: Temperature Coefficient ($\pm 30 \times 10^{-6}/^{\circ}\text{C}$): 1
- Rating code: Rated Voltage (3kV): R (as required)

1.4.1.1 *Characteristics and Ratings Codes*

Characteristics and ratings to be codified as part of the ESCC Component Number shall be as follows:

- (a) Rated Capacitance Value, C_n , expressed by means of the following codes in accordance with ESCC Basic Specification No. [21700](#). The unit quantity shall be picofarad (pF).

Capacitance Value C_n (pF)	Code
XX 10 ⁰	XX0
XX 10 ¹	XX1
XX 10 ²	XX2
XX 10 ³	XX3
XX 10 ⁴	XX4

- (b) Capacitance Tolerance expressed by the following codes in accordance with ESCC Basic Specification No. [21700](#):

Tolerance (\pm %)	Code Letter
5	J
10	K
20	M

- (c) Temperature Coefficient expressed by the following code:

Temperature Coefficient ($\pm 10^{-6}/^{\circ}\text{C}$)	Code
30	1

- (d) Rated Voltage, U_R , expressed by the following codes:

Rated Voltage U_R (kV)	Code Letter
1	M
2	P
3	R
4	S
5	Z

1.4.2 Component Type Variants and Range of Components

The component type variants and range of components applicable to this specification are as follows:

Variant Number	Package Details (Note 1)				Capacitance Range C _n (pF) (Note 4)					Weight Max (g)
	Case Type (Note 2)	Lead Type	No. of Leads	Lead Mat. & Finish (Note 3)	Rated Voltage U _R = 1kV	Rated Voltage U _R = 2kV	Rated Voltage U _R = 3kV	Rated Voltage U _R = 4kV	Rated Voltage U _R = 5kV	
01	VR30S	Radial	2	A3	390 to 2200	56 to 470	33 to 330	-	-	1
02	VR30	Radial	2	A3	2700 to 5600	560 to 1800	390 to 680	-	-	1
03	VR40	Radial	2	A3	6800 to 15000	2200 to 4700	820 to 1500	390 to 820	330 to 560	2
04	VR50	Radial	2	A3	18000 to 33000	5600 to 10000	1800 to 2700	1000 to 1800	680 to 1200	3
05	VR66	Radial	2	A3	39000 to 68000	12000 to 18000	3300 to 5600	2200 to 3300	1500 to 2200	5
06	VR84	Radial	2	A3	82000 to 100000	22000 to 39000	6800 to 12000	3900 to 6800	2700 to 4700	8
07	VR90	Radial	2	A3	120000 to 330000	47000 to 100000	15000 to 33000	8200 to 18000	5600 to 12000	19
08	CV41	Radial	2	A3	6800 to 15000	2200 to 4700	820 to 1500	390 to 820	330 to 560	2
09	CH41	Straight DIL	6	N9	6800 to 15000	2200 to 4700	820 to 1500	390 to 820	330 to 560	2
10	CH41	L DIL	6	N9	6800 to 15000	2200 to 4700	820 to 1500	390 to 820	330 to 560	2
11	CV51	Radial	2	A3	18000 to 33000	5600 to 10000	1800 to 2700	1000 to 1800	680 to 1200	3
12	CH51	Straight DIL	8	N9	18000 to 33000	5600 to 10000	1800 to 2700	1000 to 1800	680 to 1200	3
13	CH51	L DIL	8	N9	18000 to 33000	5600 to 10000	1800 to 2700	1000 to 1800	680 to 1200	3
14	CV61	Radial	2	A3	39000 to 68000	12000 to 18000	3300 to 5600	2200 to 3300	1500 to 2200	5
15	CH61	Straight DIL	10	N9	39000 to 68000	12000 to 18000	3300 to 5600	2200 to 3300	1500 to 2200	5
16	CH61	L DIL	10	N9	39000 to 68000	12000 to 18000	3300 to 5600	2200 to 3300	1500 to 2200	5
17	CV76	Radial	2	A3	82000 to 100000	22000 to 39000	6800 to 12000	3900 to 6800	2700 to 4700	8
18	CH76	Straight DIL	12	N9	82000 to 100000	22000 to 39000	6800 to 12000	3900 to 6800	2700 to 4700	8
19	CH76	L DIL	12	N9	82000 to 100000	22000 to 39000	6800 to 12000	3900 to 6800	2700 to 4700	8
20	CV91	Radial	2	A3	120000 to 330000	47000 to 100000	15000 to 33000	8200 to 18000	5600 to 12000	19

Variant Number	Package Details (Note 1)				Capacitance Range C _n (pF) (Note 4)					Weight Max (g)
	Case Type (Note 2)	Lead Type	No. of Leads	Lead Mat. & Finish (Note 3)	Rated Voltage U _R = 1kV	Rated Voltage U _R = 2kV	Rated Voltage U _R = 3kV	Rated Voltage U _R = 4kV	Rated Voltage U _R = 5kV	
21	CH91	Straight DIL	28	N9	120000 to 330000	47000 to 100000	15000 to 33000	8200 to 18000	5600 to 12000	19
22	CH91	L DIL	28	N9	120000 to 330000	47000 to 100000	15000 to 33000	8200 to 18000	5600 to 12000	19

NOTES:

1. See Para. 1.6.
2. For Variants 01 to 07 (case type VR) the body shall be coated with epoxy resin. Variants 08 to 22 (case types CV & CH) are classified as non-insulated.
3. The lead materials and finishes shall be in accordance with the requirements of ESCC Basic Specification No. [23500](#).
4. Available capacitance values and tolerances are as follows:
 - Tolerance: ±5%; value series: E12
 - Tolerance: ±10%; value series: E12
 - Tolerance: ±20%; value series: E12

1.5 **MAXIMUM RATINGS**

The maximum ratings shall not be exceeded at any time during use or storage.

Maximum ratings shall only be exceeded during testing to the extent specified in this specification and when stipulated in Test Methods and Procedures of the ESCC Generic Specification.

Characteristics	Symbols	Maximum Ratings	Units	Remarks
Rated Voltage	U _R	1, 2, 3, 4, 5	kV	Note 1
Operating Temperature Range	T _{op}	-55 to +125	°C	Without derating. T _{amb}
Storage Temperature Range	T _{stg}	-55 to +125	°C	
Soldering Temperature	T _{sol}	+260	°C	Note 2

NOTES:

1. As required; See Para. 1.4.2.
2. Duration 5 seconds maximum at a distance of not less than 1.5mm from the body and the same lead shall not be resoldered until 3 minutes have elapsed.

1.6 PHYSICAL DIMENSIONS

1.6.1 Case Type VR with Radial Leads

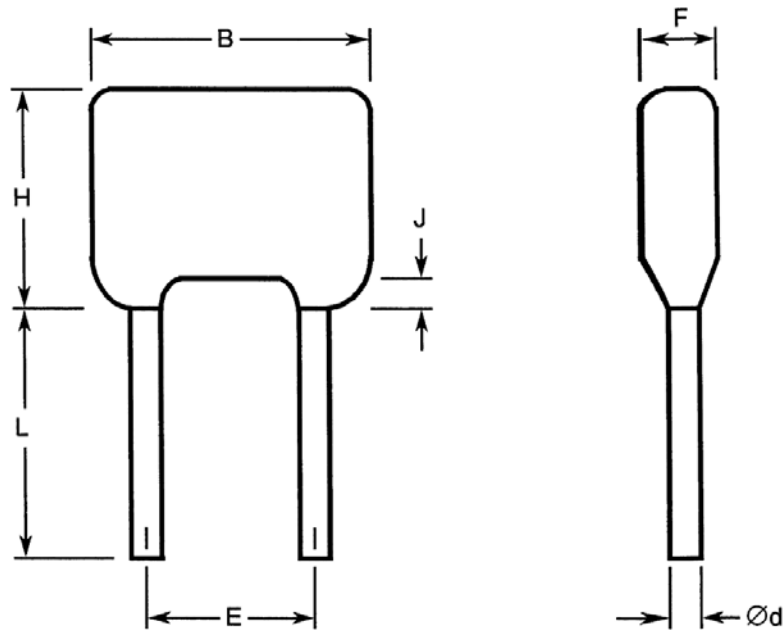

Variant Number	Case Type	Dimensions (mm)								
		B Max	Ød (Note 1)		E		F Max	H Max	J Max	L Min (Note 1)
			Min	Max	Min	Max				
01	VR30S	7.62	0.46	0.56	4.58	5.58	5	6.1	1.5	31.7
02	VR30	7.62	0.46	0.56	4.58	5.58	5	9.62	1.5	31.7
03	VR40	10.16	0.46	0.56	4.58	5.58	5	11.7	1.5	31.7
04	VR50	12.7	0.59	0.69	9.66	10.66	5.1	14.2	1.5	31.7
05	VR66	17.5	0.86	0.96	14.2	15.2	6.4	16.5	1.5	31.7
06	VR84	23.62	0.86	0.96	20.4	22	6.4	19.78	1.5	31.7
07	VR90	23.5	0.86	0.96	20.4	22	6.4	42	1.5	31.7

NOTES:

- Both leads.

1.6.2 Case Type CV with Radial Leads

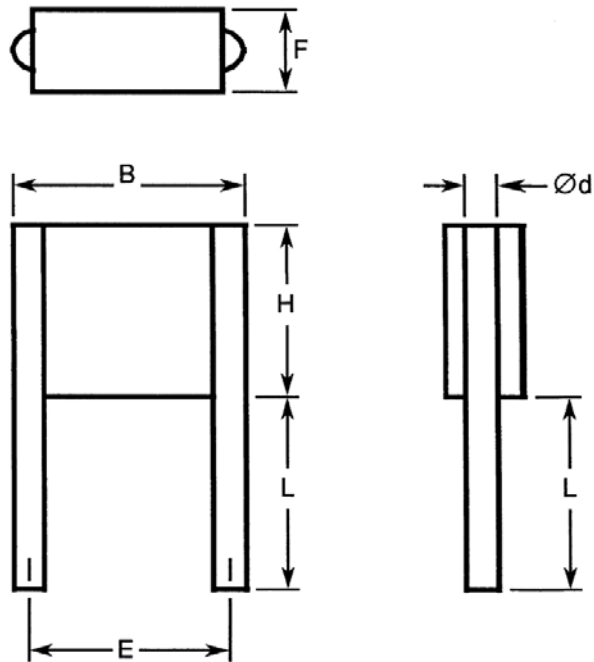

Variant Number	Case Type	Dimensions (mm)								
		B Max	$\text{Ø}d$ (Note 1)		E		F Max	H Max	L (Note 1)	
			Min	Max	Min	Max			Min	Max
08	CV41	10.6	0.65	0.75	7.7	8.7	3.8	8.7	22	28
11	CV51	11.9	0.85	0.95	9.66	10.66	3.8	10.7	22	28
14	CV61	16.5	0.85	0.95	14.74	15.74	3.8	13.6	22	28
17	CV76	22.7	0.85	0.95	20.4	22	3.8	16.6	22	28
20	CV91	22.7	1.15	1.25	20.4	22	3.8	40.6	22	28

NOTES:

- Both leads.

1.6.3 Case Type CH with Straight DIL Leads

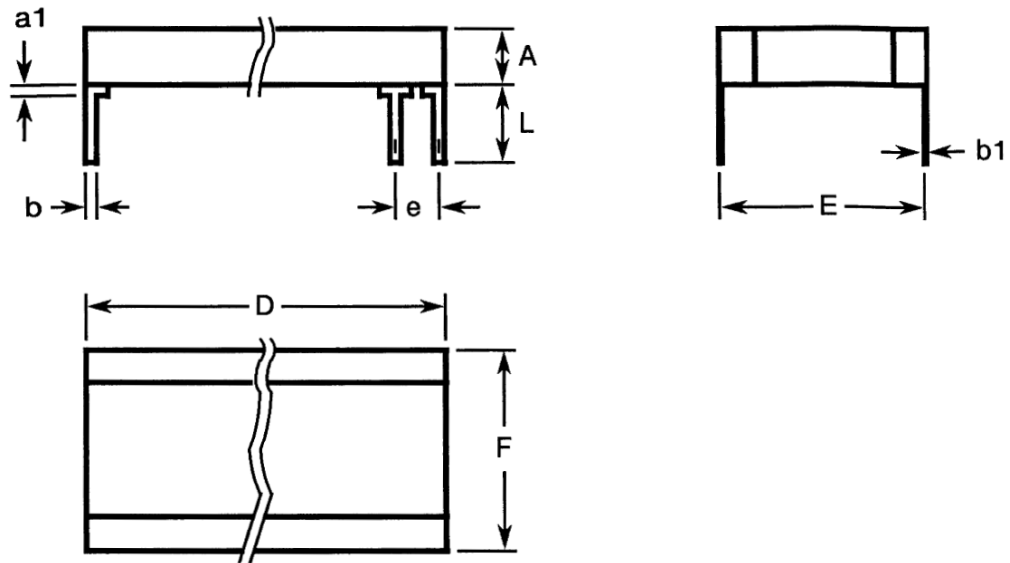

Variant Number	Case Type	Dimensions (mm)													
		A Max	a1 Max (Note 1)	b (Note 1)		b1 (Note 1)		D Max	E (Note 1)		e (Note 1)		F Max	L (Note 1)	
				Min	Max	Min	Max		Min	Max	Min	Max			
09	CH41	3.8	2	0.45	0.55	0.204	0.304	8.7	7.7	8.7	2.49	2.59	9.2	12	14
12	CH51	3.8	2	0.45	0.55	0.204	0.304	10.7	9.66	10.66	2.49	2.59	10.7	12	14
15	CH61	3.8	2	0.45	0.55	0.204	0.304	13.6	13.5	14.5	2.49	2.59	14.9	12	14
18	CH76	3.8	2	0.45	0.55	0.204	0.304	16.6	19.52	21.12	2.49	2.59	21.6	12	14
21	CH91	3.8	2	0.45	0.55	0.204	0.304	40.6	19.52	21.12	2.49	2.59	24	12	14

NOTES:

1. All leads.

1.6.4 Case Type CH with L DIL Leads

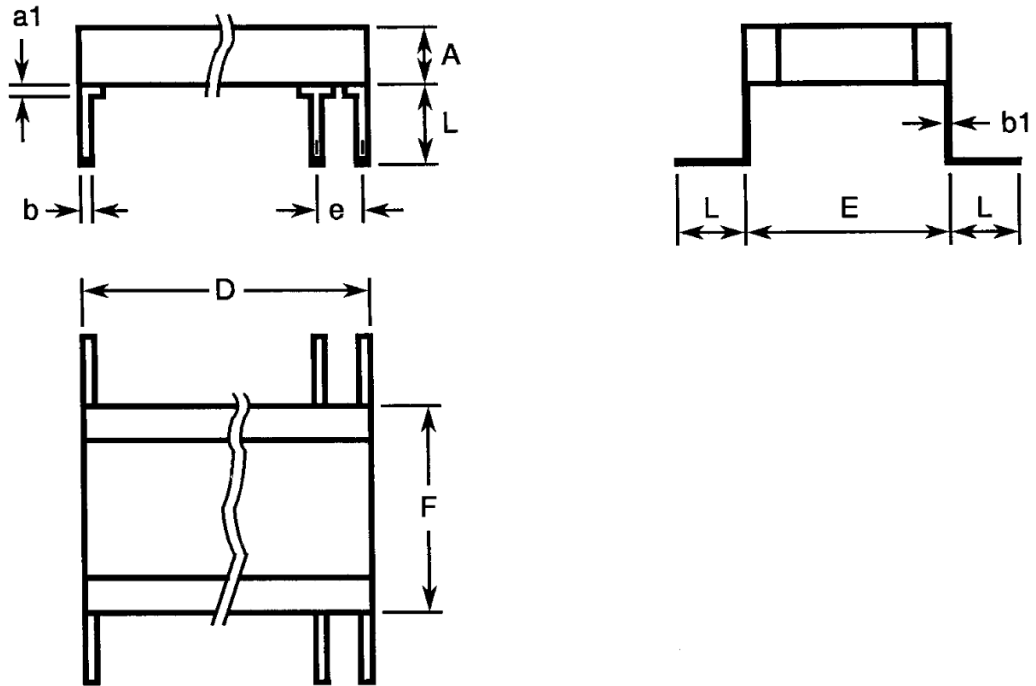

Variant Number	Case Type	Dimensions (mm)													
		A Max	a1 Max (Note 1)	b (Note 1)		b1 (Note 1)		D Max	E (Note 1)		e (Note 1)		F Max	L (Note 1)	
				Min	Max	Min	Max		Min	Max	Min	Max			
10	CH41	3.8	2	0.45	0.55	0.204	0.304	8.7	7.7	8.7	2.49	2.59	9.2	2.04	3.04
13	CH51	3.8	2	0.45	0.55	0.204	0.304	10.7	9.66	10.66	2.49	2.59	10.7	2.04	3.04
16	CH61	3.8	2	0.45	0.55	0.204	0.304	13.6	13.5	14.5	2.49	2.59	14.9	2.04	3.04
19	CH76	3.8	2	0.45	0.55	0.204	0.304	16.6	19.52	21.12	2.49	2.59	21.6	2.04	3.04
22	CH91	3.8	2	0.45	0.55	0.204	0.304	40.6	19.52	21.12	2.49	2.59	24	2.04	3.04

NOTES:

1. All leads.

1.7 FUNCTIONAL DIAGRAM



NOTES:

1. For case type CH, all leads on each side of the component are connected to the same capacitor terminal.

2 REQUIREMENTS

2.1 GENERAL

The complete requirements for procurement of the components specified herein are as stated in this specification and the ESCC Generic Specification. Permitted deviations from the Generic Specification, applicable to this specification only, are listed below.

Permitted deviations from the Generic Specification and this Detail Specification, formally agreed with specific Manufacturers on the basis that the alternative requirements are equivalent to the ESCC requirement and do not affect the component's reliability, are listed in the appendices attached to this specification.

2.1.1 Deviations from the Generic Specification

2.1.1.1 *Deviations from Special In-Process Controls - Chart F2*

(a) Robustness of Terminations: Shall be replaced with a lead peel test as specified in Para. 2.3 herein.

2.1.1.2 *Deviations from Qualification and Periodic Tests - Chart F4*

(a) Steady State Humidity (85/85): Not applicable and shall be replaced in Chart F4 Subgroup 1A of the Generic Specification by a Damp Heat Steady State test as follows:

Components shall be subjected to Test Cab of IEC Publication No. 60068-2-78. The following details shall apply:

- Test Conditions:
 - (a) Temperature: $40 \pm 2^{\circ}\text{C}$
 - (b) Relative humidity: $93 \pm 3\%$
 - (c) Duration: 56 days
 - (d) Bias during test: Half the samples shall have no voltage applied; the remaining half shall have 100V applied.
- Data Points:

Prior to the test, Capacitance shall be measured as specified in Para. 2.5 Intermediate and End-Point Electrical Measurements.

On completion of testing, the components shall be subjected to standard atmospheric conditions for recovery for 6 to 24 hours.

After recovery, the components shall be visually examined. There shall be no evidence of damage. Capacitance, Change in Capacitance, Tangent of Loss Angle, Insulation Resistance and Voltage Proof (Body Insulation) shall be measured as specified in Para. 2.5 Intermediate and End-Point Electrical Measurements. Change in Capacitance shall be related to the initial measurements.

2.2 MARKING

The marking shall be in accordance with the requirements of ESCC Basic Specification No. [21700](#) and as follows.

The information to be marked on the component shall be:

- (a) The ESCC qualified components symbol (for ESCC qualified components only).
- (b) The ESCC Component Number (see Para. 1.4.1).
- (c) Traceability information.

2.3 ROBUSTNESS OF TERMINATIONS

The terminations of these devices are classified as rigid.

Robustness of Terminations shall be performed as a lead peel test on a sample of 5 components from each manufacturing lot with 0 failures allowed. The sample components shall be leaded but not encapsulated or coated. Where necessary, the leads of the component under test shall be bent through 90° in the plane of the joint such that a tensile force applied to the leads will result in a peeling force being applied to the leads' joint.

A tensile force shall be applied evenly across the length, on the capacitor terminal, to all leads on that side of the component together, until the lead joint peels. All leads shall be tested.

The minimum peeling force shall be as follows:

- For case types VR & CV: 8.9N
- For case type CH: 22.25N

2.4 ELECTRICAL MEASUREMENTS AT ROOM, HIGH AND LOW TEMPERATURES

Electrical measurements shall be performed at room, high and low temperatures.

2.4.1 Room Temperature Electrical Measurements

The measurements shall be performed at $T_{amb} = +22 \pm 3^{\circ}C$.

Characteristics	Symbols	Test Method and Conditions	Tolerance (\pm %)	Limits		Units
				Min	Max	
Capacitance	C _A	ESCC No. 3001	5	0.95C _n	1.05C _n	pF
			10	0.9C _n	1.1C _n	
			20	0.8C _n	1.2C _n	
Tangent of Loss Angle	tg δ	ESCC No. 3001	All	-	10 $\times 10^{-4}$	-
Insulation Resistance (Dielectric)	R _{ID}	ESCC No. 3001 C _n \leq 10000pF C _n > 10000pF	All	100	-	G Ω
				1000	-	G Ω .nF
Insulation Resistance (Body Insulation)	R _{IB}	ESCC No. 3001 Case type VR only Note 1 C _n \leq 10000pF C _n > 10000pF	All	100	-	G Ω
				1000	-	G Ω .nF
Voltage Proof (Dielectric)	VP _D	ESCC No. 3001 For U _R = 1000V For U _R \geq 2000V	All	1.5U _R	-	V
				1.3U _R	-	
Voltage Proof (Body Insulation)	VP _B	ESCC No. 3001 Case type VR only Note 1 For U _R = 1000V For U _R \geq 2000V	All	1.5U _R	-	V
				1.3U _R	-	

NOTES:

- The measurements shall be performed on a sample of 5 components from each manufacturing lot with 0 failures allowed. In the event of any failure a 100% inspection may be performed. In the case of a 100% inspection, a 1% total percent defective is allowed.

2.4.2 High and Low Temperatures Electrical Measurements

Characteristics	Symbols	Test Method and Conditions (Note 1)	Limits		Units
			Min	Max	
Insulation Resistance (Dielectric)	R _{ID}	ESCC No. 3001 T _{amb} = +125 ±2°C Note 2 C _n ≤ 10000pF C _n > 10000pF	10	-	GΩ
			100	-	GΩ.nF
Insulation Resistance (Body Insulation)	R _{IB}	ESCC No. 3001 T _{amb} = +125 ±2°C Case type VR only Note 2 C _n ≤ 10000pF C _n > 10000pF	10	-	GΩ
			100	-	GΩ.nF
Temperature Coefficient	TC	ESCC No. 3001 T _{amb} = -55 ±2°C, +20 ±2°C, +125 ±2°C Note 3	-30	+30	10 ⁻⁶ /°C

NOTES:

1. The measurements shall be performed on a sample of 5 components from each manufacturing lot with 0 failures allowed. In the event of any failure a 100% inspection may be performed.
2. Guaranteed but not tested during Chart F3 of the Generic Specification; only tested in Temperature Characterisation during Chart F4 of the Generic Specification.
3. In the case of a 100% inspection, a 1% total percent defective is allowed.

2.5 INTERMEDIATE AND END-POINT ELECTRICAL MEASUREMENTS

Unless otherwise specified, the measurements shall be performed at $T_{amb} = +22 \pm 3^{\circ}\text{C}$.

Unless otherwise specified the test methods and test conditions shall be as per the corresponding test defined in Para. 2.4.1 Room Temperature Electrical Measurements.

Test Reference per ESCC No. 3001	Characteristics	Symbols	Limits		Units	
			Min	Max		
Rapid Change of Temperature Initial Measurements Final Measurements	Capacitance	C_A	Note 1			
	Capacitance	C_A	Note 1			
	Change in Capacitance	$\Delta C_A/C_A$	-1	+1	%	
	Tangent of Loss Angle	$\text{tg}\delta$	-	20×10^{-4}	-	
Damp Heat Steady State Initial Measurements Final Measurements	Capacitance	C_A	Note 1			
	Capacitance	C_A	Note 1			
	Change in Capacitance	$\Delta C_A/C_A$	-2	+2	%	
	Tangent of Loss Angle	$\text{tg}\delta$	-	20×10^{-4}	-	
	Insulation Resistance (Dielectric):	$C_n \leq 10000\text{pF}$	R_{ID}	10	-	GΩ
				100	-	GΩ.nF
	Insulation Resistance (Body Insulation) (Note 2):	$C_n \leq 10000\text{pF}$	R_{IB}	10	-	GΩ
				100	-	GΩ.nF
	Voltage Proof (Body Insulation) (Note 2)		V_{PB}	Note 1		

Test Reference per ESCC No. 3001	Characteristics	Symbols	Limits		Units	
			Min	Max		
Operating Life						
Initial Measurements	Capacitance	C_A	Note 1			
Intermediate Measurements (1000 hours) (Note 3)	Capacitance	C_A	Note 1			
	Change in Capacitance	$\Delta C_A/C_A$	-3	+3	%	
	Insulation Resistance (Dielectric):	R_{ID}				
	$C_n \leq 10000\text{pF}$		10	-	$G\Omega$	
	$C_n > 10000\text{pF}$		100	-	$G\Omega.nF$	
	Insulation Resistance (Body Insulation) (Note 2):	R_{IB}				
	$C_n \leq 10000\text{pF}$		10	-	$G\Omega$	
	$C_n > 10000\text{pF}$		100	-	$G\Omega.nF$	
	Final Measurements (1000 or 2000 hours) (Note 4)	Capacitance	C_A	Note 1		
		Change in Capacitance	$\Delta C_A/C_A$	-3	+3	%
Tangent of Loss Angle		$\text{tg}\delta$	-	20×10^{-4}	-	
Insulation Resistance (Dielectric):		R_{ID}				
$C_n \leq 10000\text{pF}$			10	-	$G\Omega$	
$C_n > 10000\text{pF}$			100	-	$G\Omega.nF$	
Insulation Resistance (Body Insulation) (Note 2):		R_{IB}				
$C_n \leq 10000\text{pF}$			10	-	$G\Omega$	
$C_n > 10000\text{pF}$			100	-	$G\Omega.nF$	
Voltage Proof (Dielectric)		V_{PD}	Note 1			
Voltage Proof (Body Insulation) (Note 2)	V_{PB}	Note 1				
Temperature Characterisation	Insulation Resistance (Dielectric) at $T_{amb} = +125 \pm 2^\circ\text{C}$	R_{ID}	Note 5			
	Insulation Resistance (Body Insulation) at $T_{amb} = +125 \pm 2^\circ\text{C}$ (Note 2)	R_{IB}	Note 5			
	Temperature Coefficient	TC	Note 5			

Test Reference per ESCC No. 3001	Characteristics	Symbols	Limits		Units
			Min	Max	
Resistance to Soldering Heat Initial Measurements Final Measurements	Capacitance	C_A	Note 1		%
	Capacitance	C_A	Note 1		
	Change in Capacitance	$\Delta C_A / C_A$	-1	+1	
	Insulation Resistance (Dielectric)	R_{ID}	Note 1		
	Insulation Resistance (Body Insulation) (Note 2)	R_{IB}	Note 1		

NOTES:

1. As specified in Para. 2.4.1 Room Temperature Electrical Measurements.
2. Case type VR only.
3. Intermediate measurements are optional at the Manufacturer's discretion.
4. 1000 hours is applicable to Periodic Testing for extension of qualification. 2000 hours is applicable to Qualification Testing, and to Periodic Testing for renewal of qualification after lapse.
5. As specified in Para. 2.4.2 High and Low Temperatures Electrical Measurements.

2.6

BURN-IN

The requirements for Burn-in are specified in the ESCC Generic Specification. The following conditions shall also apply:

- After Burn-in, the components shall be removed from the chamber and allowed to cool under normal atmospheric conditions for recovery for 24 hours minimum.

APPENDIX A
AGREED DEVIATIONS FOR AVX LTD (GB)

Items Affected	Description of Deviations
Para. 2.1.1.1 Deviations from Special In-Process Controls - Chart F2	Microsection Inspection: may be performed using AVX inspection document as per PID.
	Internal Visual Inspection: may be performed using AVX inspection document as per PID.
Para. 2.1.1 Deviations from the Generic Specification: Screening Test - Chart F3	External Visual Inspection: may be performed using AVX inspection document as per PID.
Para. 2.1.1 Deviations from Generic Specification: Qualification and Periodic Tests - Chart F4	External Visual Inspection: may be performed using AVX inspection document as per PID.