



**RF COAXIAL CONNECTORS, TYPE SMA,
50 OHMS, ADAPTORS AND
CONNECTING PIECES**

ESCC Detail Specification No. 3402/003

Issue 4	March 2018
---------	------------



LEGAL DISCLAIMER AND COPYRIGHT

European Space Agency, Copyright © 2018. All rights reserved.

The European Space Agency disclaims any liability or responsibility, to any person or entity, with respect to any loss or damage caused, or alleged to be caused, directly or indirectly by the use and application of this ESCC publication.

This publication, without the prior permission of the European Space Agency and provided that it is not used for a commercial purpose, may be:

- copied in whole, in any medium, without alteration or modification.
- copied in part, in any medium, provided that the ESCC document identification, comprising the ESCC symbol, document number and document issue, is removed.

DOCUMENTATION CHANGE NOTICE

(Refer to <https://escies.org> for ESCC DCR content)

DCR No.	CHANGE DESCRIPTION
1100	Specification upissued to incorporate changes per DCR.

TABLE OF CONTENTS

1	GENERAL	6
1.1	SCOPE	6
1.2	TYPE VARIANTS	6
1.3	MAXIMUM RATINGS	6
1.4	PARAMETER DERATING INFORMATION (FIGURE 1)	6
1.5	PHYSICAL DIMENSIONS	6
1.6	STANDARD TEST CONNECTOR INTERFACE	6
2	APPLICABLE DOCUMENTS	14
3	TERMS, DEFINITIONS, ABBREVIATIONS, SYMBOLS AND UNITS	14
4	REQUIREMENTS	14
4.1	GENERAL	14
4.2	DEVIATIONS FROM GENERIC SPECIFICATION	14
4.2.1	Deviations from Special In-process Controls	14
4.2.2	Deviations from Final Production Tests (Chart II)	14
4.2.3	Deviations from Burn-in Tests (Chart III)	14
4.2.4	Deviations from Qualification Tests (Chart IV)	14
4.2.5	Deviations from Lot Acceptance Tests (Chart V)	14
4.3	MECHANICAL REQUIREMENTS	14
4.3.1	Dimension Check	14
4.3.2	Weight	15
4.3.3	Coupling Proof Torque	15
4.3.4	Cable Retention Force	15
4.3.5	Mating and Unmating Forces	15
4.3.6	Endurance	15
4.3.7	Residual Magnetism	15
4.3.7.1	Beryllium copper, copper underplate, gold-plated connectors.	15
4.3.7.2	Beryllium copper, nickel underplate, gold-plated connectors.	15
4.3.7.3	Stainless steel connectors	15
4.3.8	Contact Engagement and Separation Forces	16
4.3.9	Contact Retention	16
4.4	MATERIALS AND FINISHES	16
4.4.1	Beryllium Copper Version Gold Plated	17
4.4.2	Stainless Steel Version Electro-passivated	17
4.4.3	Stainless Steel Version Gold Plated	18
4.4.4	Iron Nickel Gold Plated Hermetic Type	19

4.5	MARKING	19
4.5.1	General	19
4.5.2	The ESCC Component Number	19
4.5.3	Characteristics	19
4.5.3.1	Variants of Fixed Configuration	19
4.5.3.2	Variants where Dimensions A and B of Figure 2(b) are indicated by a Maximum Only	20
4.5.3.3	Type of Plating/Material	20
4.5.3.4	Length Values	20
4.5.3.5	Tolerance	20
4.5.4	Traceability Information	21
4.5.5	Marking of Small Components	21
4.6	ELECTRICAL MEASUREMENTS	21
4.6.1	Electrical Measurements at Room Temperature	21
4.6.2	Electrical Measurements at High and Low Temperatures (Table 3)	21
4.6.3	Circuits for Electrical Measurements	21
4.7	BURN-IN TESTS (TABLES 4 AND 5)	21
4.8	ENVIRONMENTAL AND ENDURANCE TESTS (CHARTS IV AND V OF ESCC GENERIC SPECIFICATION NO. 3402)	21
4.8.1	Measurements and Inspections on Completion of Environmental Tests	21
4.8.2	Measurements and Inspections at Intermediate Points during Endurance Tests	21
4.8.3	Measurements and Inspections on Completion of Endurance Tests	22
4.8.4	Conditions for Operating Life Tests (Part of Endurance Testing)	22
4.8.5	Electrical Circuits for Operating Life Tests	22
4.8.6	Conditions for High Temperature Storage Test (Part of Endurance Testing)	22

1 GENERAL

1.1 SCOPE

This specification details the ratings, physical and electrical characteristics, test and inspection data for RF Coaxial Connectors, Type SMA, 50 Ohms, Adaptors and Connecting Pieces. It shall be read in conjunction with ESCC Generic Specification No. 3402, the requirements of which are supplemented herein.

1.2 TYPE VARIANTS

A list of the type variants of the connectors specified herein, which are also covered by this specification, is given in Table 1(a).

For each type variant, the full and electrical and physical characteristics are given in individual Figures 2(b) at the end of this specification.

1.3 MAXIMUM RATINGS

The maximum ratings, which shall not be exceeded at any time during use or storage, applicable to the connectors specified herein, are as scheduled in Table 1(b).

1.4 PARAMETER DERATING INFORMATION (FIGURE 1)

The derating information applicable to the connectors specified herein is shown in Figure 1.

1.5 PHYSICAL DIMENSIONS

The physical dimensions of the connectors specified herein are shown in Figures 2(a) and 2(b).

1.6 STANDARD TEST CONNECTOR INTERFACE

Whenever gauges are required for mating with the connectors under test, their physical dimensions shall be in accordance with those specified in Figure 3.

TABLE 1(a) – TYPE VARIANTS

Variant	Description
01	Straight Adaptor, Male - Male (Note 3)
02	Straight Adaptor, Male - Female (Note 3)
03	Straight Adaptor, Female - Female (Note 3)
04	Straight Bulkhead Adaptor, Female - Female (Note 3)
05	Elbow Adaptor, Male - Female
06	T-Adaptor, Female - Female/Male
07	Hermetic Adaptor, Female - Female
08	T-Adaptor, Female - Female/Female
09	Straight Flange Adaptor, Male - Female
10	Straight Flange Adaptor, Female - Female
11	Straight Adaptor, Male - Male, Maximum Operating Temperature = +165°C (Note 3)
12	Straight Adaptor, Male - Female, Maximum Operating Temperature = +165°C (Note 3)
13	Straight Adaptor, Female - Female, Maximum Operating Temperature = +165°C (Note 3)
14	Straight Bulkhead Adaptor Female – Female, Maximum Operating Temperature = +165°C (Note 3)

NOTES

1. The Variants are described in Figure 2(b).
2. For finishes, see Para. 4.4.
3. Variants 11, 12, 13 and 14 are High Temperature Capability versions of Variants 01, 02, 03 and 04 respectively.

TABLE 1(b) - MAXIMUM RATINGS

No.	Characteristics	Symbol	Maximum Ratings	Unit	Remarks
1	Peak Power at +25°C	P _{max}	20	kW	1μs
2	Power	P	2	kW	See Figures 1(a) and 1(b)
3	Nominal Impedance	Z	50	Ω	-
4	Frequency Range	f	See Figure 2(b)	GHz	-
5	Operating Voltage	V _{op}	335	V _{rms}	-
6	Operating Temperature Range	T _{op}	See Figure 2(b)	°C	-
7	Storage Temperature Range	T _{stg}	As per Operating Temperature Range	°C	-

FIGURE 1 - PARAMETER DERATING INFORMATION

FIGURE 1(a) - POWER VERSUS TEMPERATURE

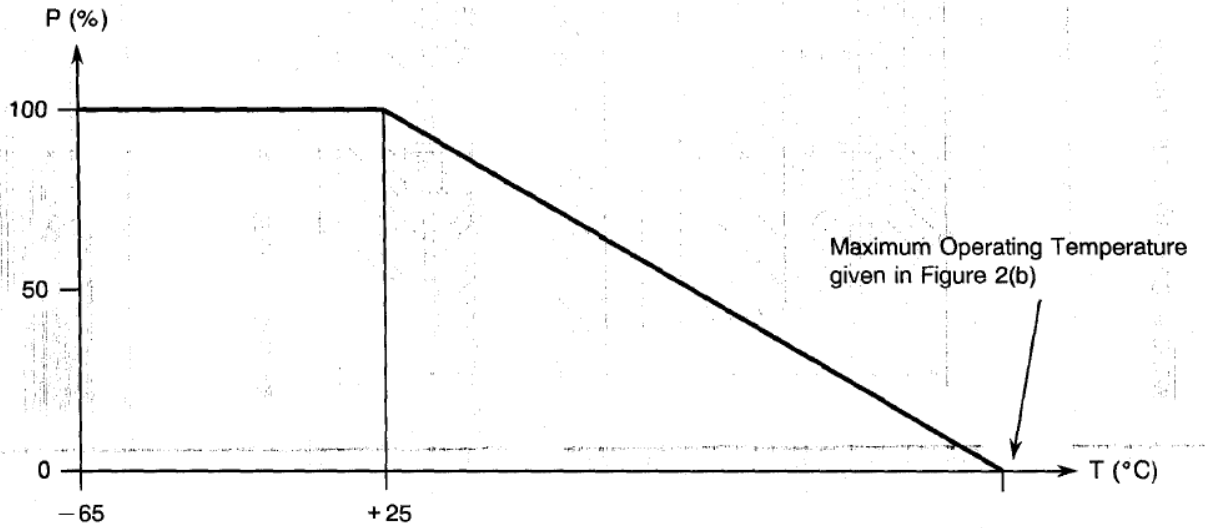

FIGURE 1(b) - POWER VERSUS FREQUENCY

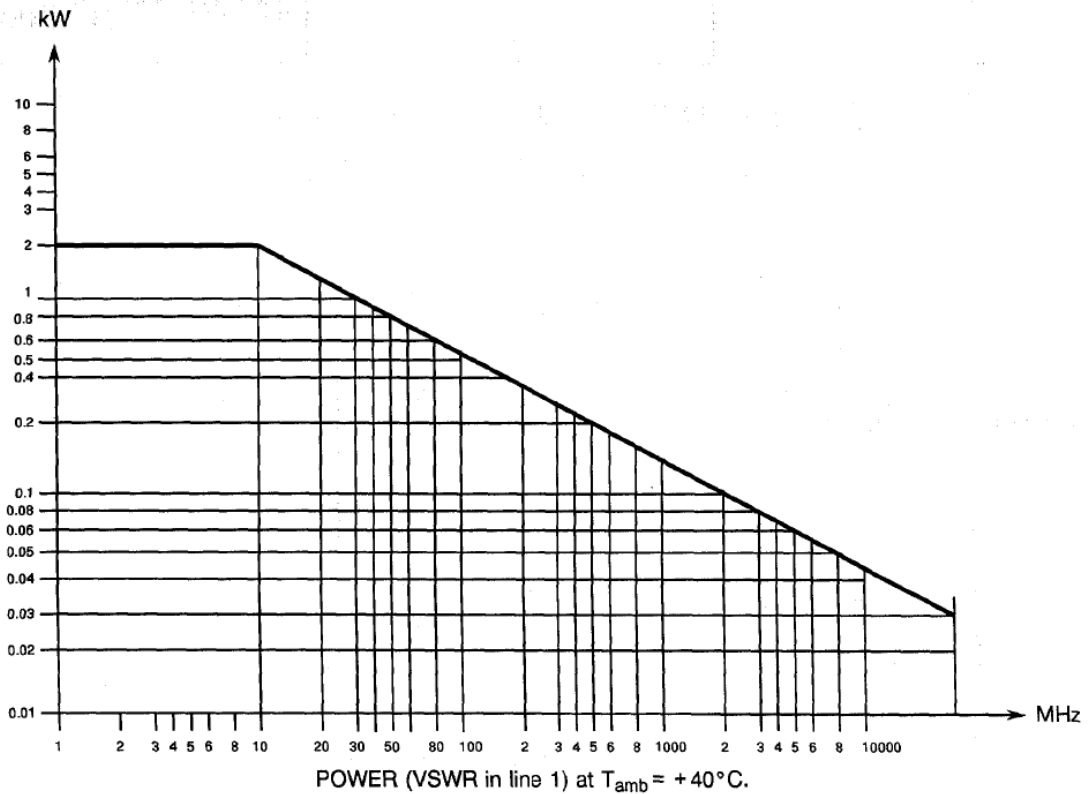

FIGURE 2 - PHYSICAL DIMENSIONS
FIGURE 2(a) - CONNECTOR INTERFACE - MALE CONTACT

FIGURE 2(a) - CONNECTOR INTERFACE - MALE CONTACT (CONTINUED)

Symbol	Millimetres		Notes
	Min.	Max.	
a	-	3.43	
b	2.54	-	
c	0.38	1.14	
Ød	-	4.592	
Øe	6.35	-	
f	-	0.08	Radius or 45° chamfer
g	0	0.2	
h	0	0.25	
j	-	2.54	
k	0.38	-	
Øl	0.9	0.94	
m	1.27	-	
Øn	-	0.38	
p	3.17	-	
Øq			
r	7.84	8	Hexagonal on flat
s	-	9.2	

FIGURE 2 - PHYSICAL DIMENSIONS (CONTINUED)

FIGURE 2(a) - CONNECTOR INTERFACE (CONTINUED) - FEMALE CONTACT

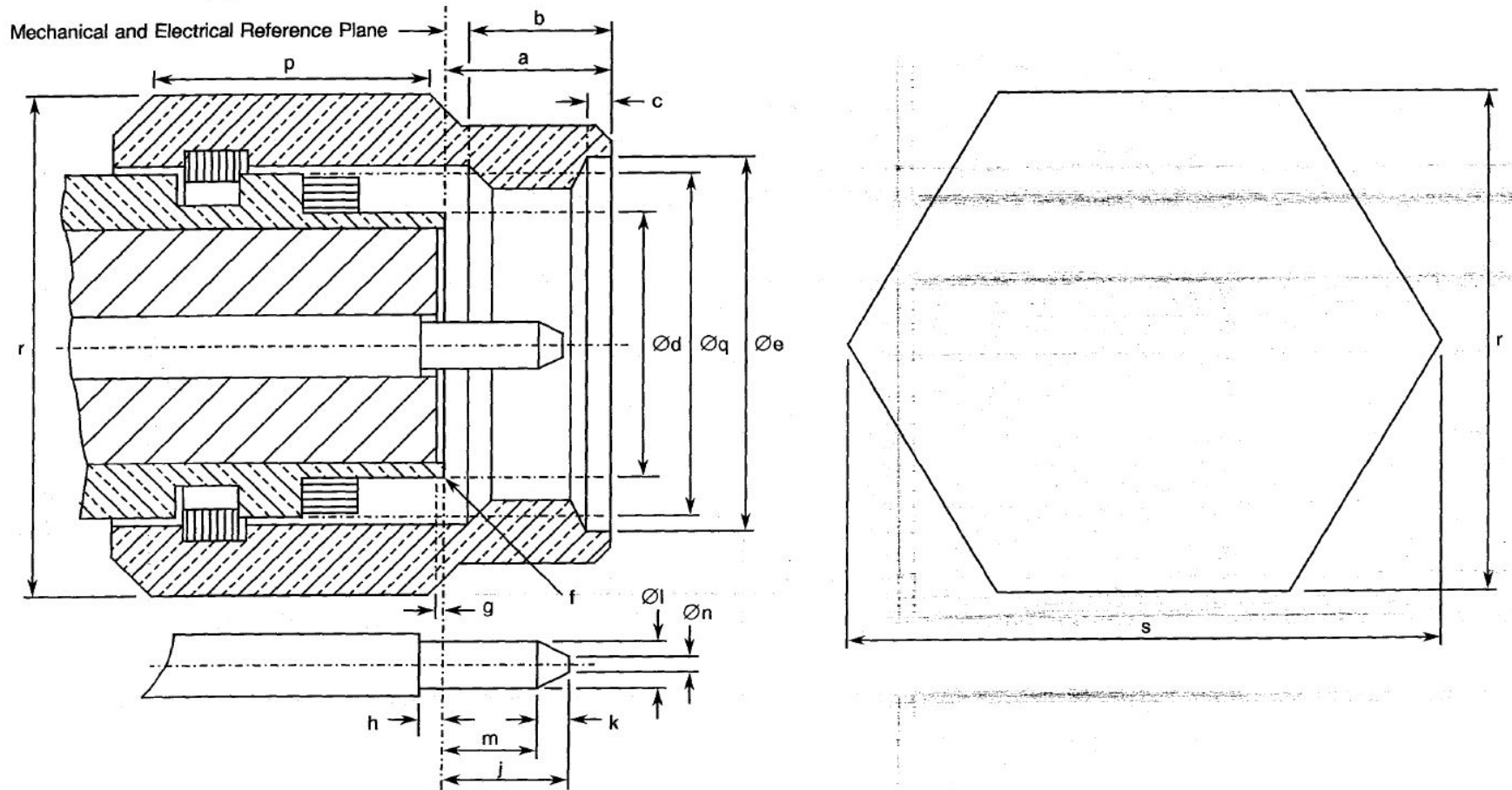
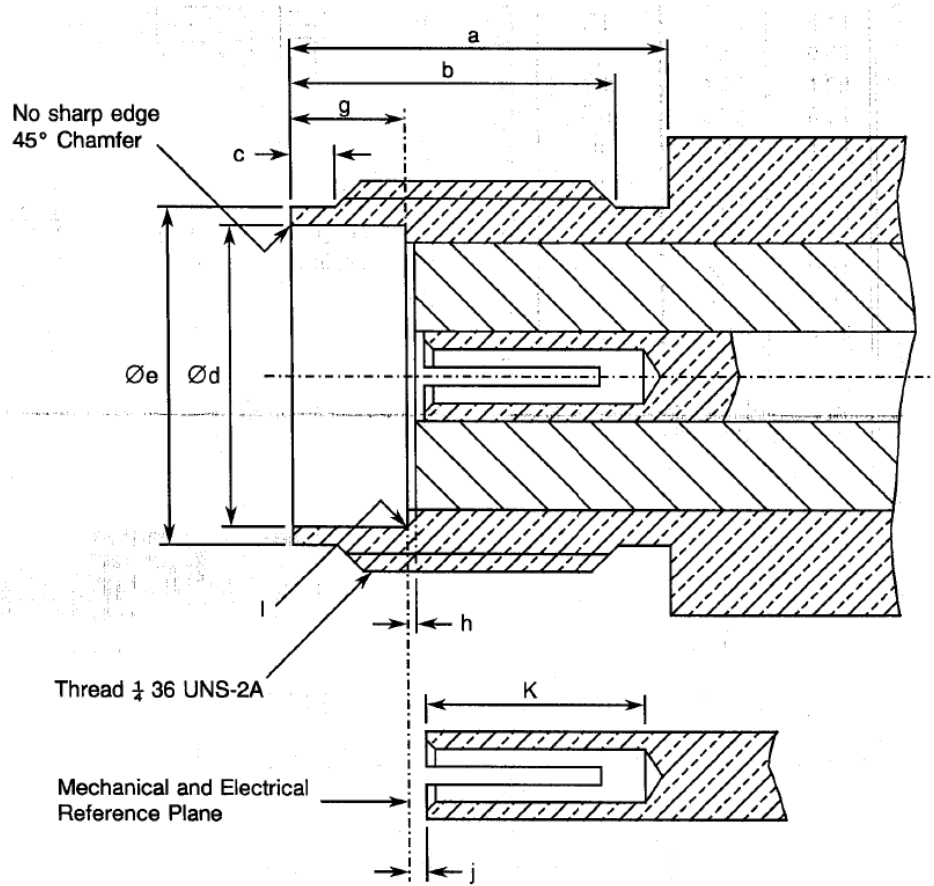

Symbol	Millimetres		Notes
	Min.	Max.	
a	5.54	-	
b	4.32	-	
c	0.38	1.14	
Ød	4.597	4.67	
Øe	5.28	5.49	
g	1.88	1.98	
h	0	0.2	
j	0	0.25	
K	2.92	-	
l	-	0.04	Radius

FIGURE 3 - STANDARD TEST CONNECTOR INTERFACE - FEMALE CONTACT

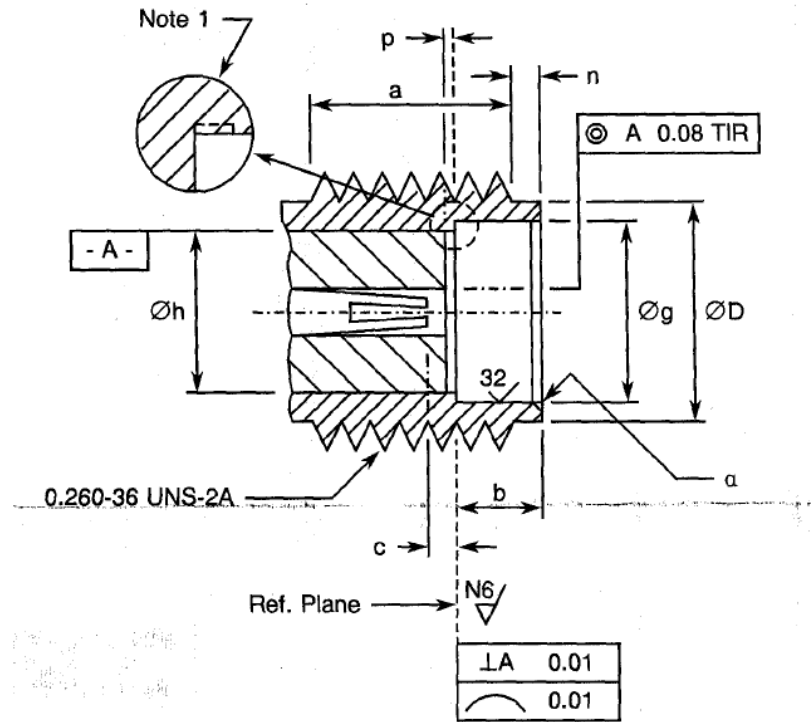

DETAIL OF INNER CONTACT

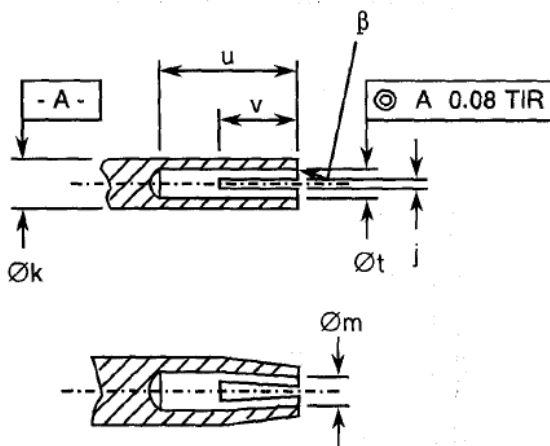

NOTES

1. No fillet permitted. Radial undercut 0.2 (max.) deep x 0.89 (max.) long permitted.

Symbol	Millimetres		Notes
	Min	Max	
a	3.81	-	
b	1.88	1.98	
c	0	0.08	Contact recess
ØD	5.28	5.49	
Øg	4.6	4.67	
Øh	4.1	4.13	
j	0.13	0.23	2 or more slots
Øk	1.27	1.29	
Øm	0.72	0.84	After closing
n	0.38	1.14	
p	0	0.05	Insert recess
u	2.54	-	
Øt	0.94	0.99	
v	1.91	2.41	
α	-	0.25	45° Chamfer
β	0.99	1.19	45° Chamfer

FIGURE 3 - STANDARD TEST CONNECTOR INTERFACE (CONTINUED) - MALE CONTACT

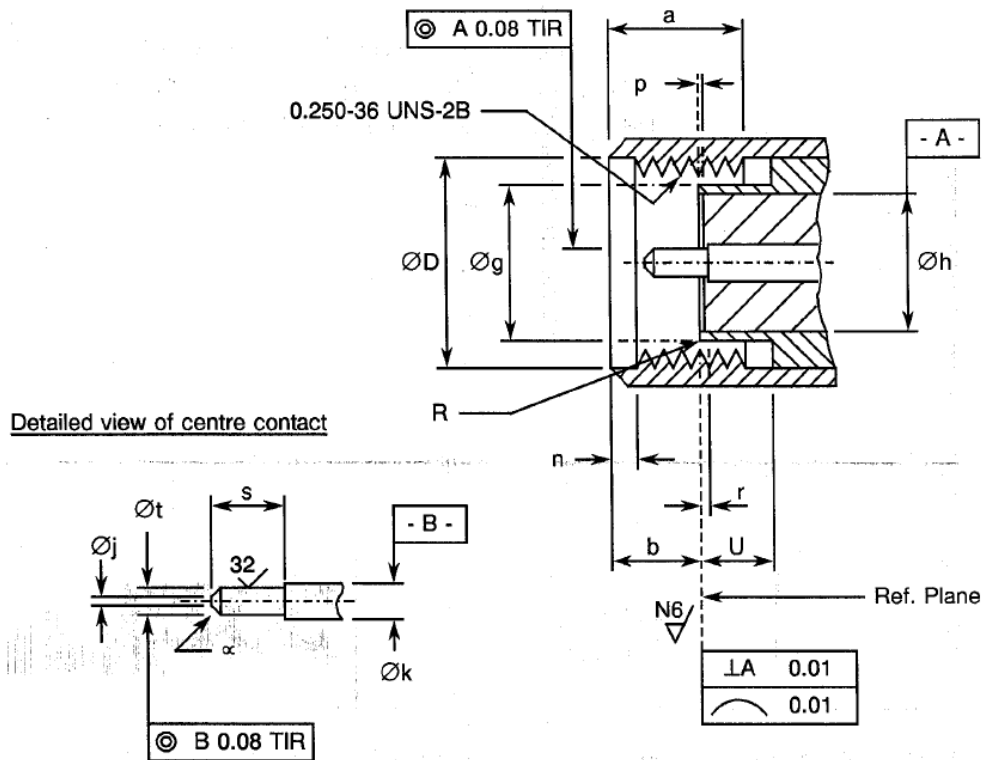

Symbol	Millimetres		Notes
	Min	Max	
a	3.71	4.32	
b	2.59	3.35	
ØD	6.48	6.73	
Øg	4.34	4.59	
Øh	4.1	4.13	
Øj	-	0.38	Flat
Øk	1.27	1.29	
n	0.64	1.14	
p	0	0.05	Insert recess
r	0	0.08	Contact recessed
R	-	0.08	Radius
s	2.03	2.29	
Øt	0.9	0.93	
U	2.03	-	
α	-	-	45 ±3° Chamfer

2 APPLICABLE DOCUMENTS

The following documents form part of this specification and shall be read in conjunction with it:

- (a) ESCC Generic Specification No. [3402](#) for RF Coaxial Connectors.
- (b) MIL-G-45204, Gold Plating, Electrodeposited.

3 TERMS, DEFINITIONS, ABBREVIATIONS, SYMBOLS AND UNITS

For the purpose of this specification, the terms, definitions, abbreviations, symbols and units specified in ESCC Basic Specification No. [21300](#) shall apply.

4 REQUIREMENTS

4.1 GENERAL

The complete requirements for procurement of the connectors specified herein are stated in this specification and ESCC Generic Specification No. [3402](#). Deviations from the Generic Specification applicable to this specification only, are listed in Para. 4.2.

Deviations from the applicable Generic Specification and this Detail Specification, formally agreed with specific Manufacturers on the basis that the alternative requirements are equivalent to the ESCC requirements and do not affect the components' reliability, are listed in the appendices attached to this specification.

4.2 DEVIATIONS FROM GENERIC SPECIFICATION

4.2.1 Deviations from Special In-process Controls

None.

4.2.2 Deviations from Final Production Tests (Chart II)

- (a) Para. 9.4, Coupling Proof Torque: shall not be performed on connectors with a female contact (only during Chart II).

4.2.3 Deviations from Burn-in Tests (Chart III)

- (a) Chart III is not applicable.

4.2.4 Deviations from Qualification Tests (Chart IV)

- (a) Para. 9.14, Cable Retention Force: Not applicable.
- (b) Para. 9.15, Cabling and Crimping Capability: Not applicable.
- (c) Para. 9.22, Soldering Proof: Not applicable.

4.2.5 Deviations from Lot Acceptance Tests (Chart V)

- (a) Para. 9.14, Cable Retention Force: Not applicable.
- (b) Para. 9.15, Cabling and Crimping Capability: Not applicable.

4.3 MECHANICAL REQUIREMENTS

4.3.1 Dimension Check

The dimensions of the connectors specified herein shall be verified in accordance with the requirements set out in Para. 9.25 of ESCC Generic Specification No. [3402](#) and shall conform to those shown in Figures 2(a) and 2(b) of this specification.

4.3.2 Weight

The maximum weight of the connectors specified herein shall be as specified in Figure 2(b).

4.3.3 Coupling Proof Torque

The requirements for testing of the coupling proof torque are specified in Section 9 of ESCC Generic Specification No. 3402. The applied torque shall be 170N.cm.

4.3.4 Cable Retention Force

Not applicable

4.3.5 Mating and Unmating Forces

The applicable measurement requirements are specified in Section 9 of ESCC Generic Specification No. 3402. The maximum torque during mating and unmating shall not exceed 24N.cm.

Whenever a test is performed on mated pairs of connectors, the pairs shall be torqued at 80-120N.cm.

4.3.6 Endurance

The applicable test requirements are specified in Section 9 of ESCC Generic Specification No. 3402. The test conditions shall be as follows:

- (a) Number of cycles: 500 for qualification; 100 for lot acceptance.
- (b) Rate: 12 cycles maximum/minute.

4.3.7 Residual Magnetism

The applicable measurement requirements are specified in Section 9 of ESCC Generic Specification No. 3402.

4.3.7.1 *Beryllium copper, copper underplate, gold-plated connectors.*

The maximum allowable value shall not exceed 20 gammas.

4.3.7.2 *Beryllium copper, nickel underplate, gold-plated connectors.*

There are no requirements in respect of residual magnetism. This version is made such that the residual magnetism does not exceed 2000 gammas.

4.3.7.3 *Stainless steel connectors*

Residual magnetism is not applicable to stainless steel versions.

4.3.8 Contact Engagement and Separation Forces

The requirements for these measurements are specified in Section 9 of ESCC Generic Specification No. 3402 and apply to female contacts only.

- (a) **Oversize Pin**
 - Steel test pin diameter : 0.9525/0.955 mm.
 - Insertion depth : 0.76/1.14 mm.
 - Number of insertions : 3.

- (b) **Engagement Force Test (Maximum Diameter Test Pin)**
 - Steel test pin diameter : 0.94/0.942 mm.
 - Engagement depth : 1.27/1.91mm.
 - Engagement force : 1360g max.

- (c) **Separation Force Test (Minimum Diameter Test Pin)**
 - Steel test pin diameter : 0.902/0.904 mm.
 - Separation depth : 1.27/1.91 mm.
 - Separation force : 28.4g min.

FIGURE 4 - TEST PIN CONFIGURATION

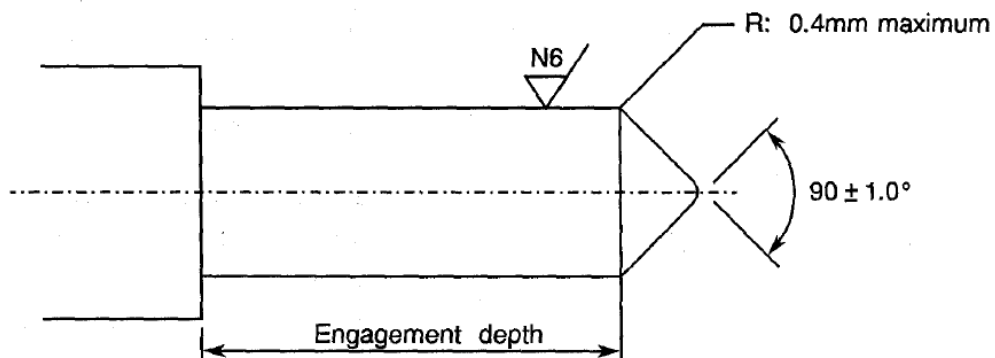

4.3.9 Contact Retention

The requirements for this test are specified in Section 9 of ESCC Generic Specification No. 3402. The test conditions are given in Figure 2(b). After testing, the connector interface dimensions shall be within the limits of Figure 2(a).

4.4 MATERIALS AND FINISHES

The materials and finishes shall be as specified herein. Where a definite material is not specified, a material which will enable the connectors specified herein to meet the performance requirements of this specification shall be used. Acceptance or approval of any constituent material does not guarantee acceptance of the finished product.

4.4.1 Beryllium Copper Version Gold Plated

(a) Shell, Coupling Nut, Centre Contact

Material : Beryllium copper (or brass for male contact only).

(i) Plating for standard version

Underplate : Nickel, 2 μ m minimum.

Plating : Gold, 1.27 μ m minimum, Type 2 Grade C of MIL-G-45204.

(ii) Plating for amagnetic version

Underplate : Copper, 2.5 μ m minimum.

Plating : Gold, 2.5 μ m minimum, Type 2 Grade C of MIL-G-45204.

(b) Inserts

Material : PTFE.

(c) Gaskets

Material : Silicone rubber.

(d) Accessories (ferrule, crimping or solder sleeves and nut)

Material : Brass or copper.

(i) Plating for standard version

Underplate : Nickel, 2 μ m minimum.

Plating : Gold, 0.5 μ m minimum, Type 2 Grade C of MIL-G-45204.

(ii) Plating for amagnetic version

Underplate : Copper, 2.5 μ m minimum.

Plating : Gold, 2.5 μ m minimum, Type 2 Grade C of MIL-G-45204.

4.4.2 Stainless Steel Version Electro-passivated

(a) Shell, Coupling Nut

Material : Stainless steel, electro-passivated.

For solder-type connectors; Rear part of shell shall be protected with:

Underplate : Nickel, 2 μ m minimum.

Plating : Gold, 1.27 μ m minimum, Type 2 Grade C of MIL-G-45204.

(b) Centre Contact

Material : Beryllium copper (or brass for male contact only).

Underplate : Nickel, 2 μ m minimum.

Plating : Gold, 1.27 μ m minimum, Type 2 Grade C of MIL-G-45204.

(c) Inserts

Material : PTFE.

(d) Gaskets

Material : Silicone.

- (e) Accessories
 - Crimping sleeve
 - Material : Brass or copper.
 - Plating : Nickel, 2µm minimum.
 - Solder sleeve
 - Material : Brass or copper.
 - Underplate : Nickel, 2µm minimum.
 - Plating : Gold, 0.5µm minimum, Type 2 Grade C of MIL-G-45204.
 - Nut
 - Material : Stainless steel, electro-passivated.
 - Washers
 - Material : Beryllium copper.
 - Plating : Nickel, 2µm minimum.

4.4.3 Stainless Steel Version Gold Plated

- (a) Shell, Coupling Nut
 - Material : Stainless steel.
 - Underplate : Nickel, 2µm minimum.
 - Plating : Gold, 1.27µm minimum, Type 2 Grade C of MIL-G-45204.
- (b) Centre Contact
 - Material : Beryllium copper (or brass for male contact only).
 - Underplate : Nickel, 2µm minimum.
 - Plating : Gold, 1.27µm minimum, Type 2 Grade C of MIL-G-45204.
- (c) Inserts
 - Material : PTFE.
- (d) Gaskets
 - Material : Silicone.
- (e) Accessories
 - Crimping or solder sleeve
 - Material : Brass or copper.
 - Underplate : Nickel, 2µm minimum.
 - Plating : Gold, 0.5µm minimum, Type 2 Grade C of MIL-G-45204.
 - Nut
 - Material : Stainless steel.
 - Underplate : Nickel, 2µm minimum.
 - Plating : Gold, 0.5µm minimum, Type 2 Grade C of MIL-G-45204.
 - Washers
 - Material : Beryllium copper.
 - Underplate : Nickel, 2µm minimum.
 - Plating : Gold, 0.5µm minimum, Type 2 Grade C of MIL-G-45204.

4.4.4 Iron Nickel Gold Plated Hermetic Type

(a) Shell

Material : Iron.

Underplate : Nickel, 2 μ m minimum.

Plating : Gold, 1.27 μ m minimum, Type 2 Grade C of MIL-G-45204.

(b) Centre Contact

Material : Steel.

Underplate : Nickel, 2 μ m minimum.

Plating : Gold, 1.27 μ m minimum, Type 2 Grade C of MIL-G-45204.

(c) Inserts

Material : Glass.

4.5 MARKING

4.5.1 General

The marking of all components delivered to this specification shall be in accordance with the requirements of ESCC Basic Specification No. 21700 and the following paragraphs. Each component shall be marked in respect of:

(a) The ESCC Component Number.

(b) Characteristics.

(c) Traceability Information.

4.5.2 The ESCC Component Number

Each component shall bear the ESCC Component Number which shall be constituted and marked as follows:

Example: 340200301B

– Detail Specification Number: 3402003

– Type Variant (see Table 1(a)): 01

– Testing Level (B or C, as applicable): B

4.5.3 Characteristics

Characteristics cover the type of plating/material and 2 different dimensional aspects:

(a) Variants of fixed configuration.

(b) Variants where the rear end (length of contact A and length of insert B) may vary within a range limited by a specified maximum value.

4.5.3.1 *Variants of Fixed Configuration*

Each component shall be marked in respect of:

(a) Type of plating/material.

(b) Number.

The information shall be constituted and marked as follows:

Example: 201

– Type of plating/material (see Para. 4.5.3.3): 2

– Number (shall always be 01): 01

4.5.3.2 *Variants where Dimensions A and B of Figure 2(b) are indicated by a Maximum Only*
 Each component shall be marked in respect of:

- (a) Type of plating/material.
- (b) Length and tolerance of centre contact (dimension A) (see Note 4).
- (c) Length and tolerance of insert (dimension B) (see Note 4).

The information shall be constituted and marked as follows:

Example: 213D00W02D50C

- Type of plating/material (see Para. 4.5.3.3): 2
- Contact length A: 13mm (see Para. 4.5.3.4): 13D00
- Tolerance on A: ± 0.05 mm (see Para. 4.5.3.5): W
- Insert length B: 2.5mm (see Para. 4.5.3.4): 02D50
- Tolerance on B: ± 0.25 mm (see Para. 4.5.3.5):C

NOTES

1. Dimension A shall always be greater than B. Both values shall always be positive.
2. When dimension B (insert) is flush with the flange (B = 0), the insert length shall be marked 00D00 with the appropriate tolerance.
3. When applicable, Figure 2(b) makes reference to Para. 4.5.3.
4. The length values of the centre contact and insert shall be marked only on the primary package.

4.5.3.3 *Type of Plating/Material*

The type of plating/material shall be identified by means of the following codes:

Code	Type of Plating/Material	Para.
1	Beryllium copper gold plated, copper underplate (amagnetic version)	4.4.1
2	Beryllium copper gold plated, nickel underplate (standard version)	4.4.1
3	Stainless steel electro-passivated	4.4.2
4	Stainless steel gold plated	4.4.3

For hermetic types (see Para. 4.4.4), only plating code 2 is available.

4.5.3.4 *Length Values*

Length values shall be expressed by means of the following codes. The unit quantity for marking shall be millimetres.

Length Value	Code
XX.XX	XXDXX

4.5.3.5 *Tolerance*

The tolerance on length values shall be indicated by the letter codes specified hereafter:

Tolerance (mm)	Code Letter
± 0.05	W
± 0.1	B
± 0.25	C

4.5.4 Traceability Information

Each component shall be marked in respect of traceability information in accordance with the requirements of ESCC Basic Specification No. [21700](#).

4.5.5 Marking of Small Components

When it is considered that the component: is too small to accommodate the marking as specified above as much as space permits shall be marked. The order of precedence shall be as specified in Para. 4.5.1. The marking information in full shall accompany each component in its primary package.

4.6 ELECTRICAL MEASUREMENTS

4.6.1 Electrical Measurements at Room Temperature

The parameters to be measured in respect of electrical characteristics are scheduled in Table 2. Unless otherwise specified, the measurements shall be performed at $T_{amb} = +22 \pm 3 \text{ }^\circ\text{C}$.

4.6.2 Electrical Measurements at High and Low Temperatures (Table 3)

Not applicable.

4.6.3 Circuits for Electrical Measurements

Not applicable.

4.7 BURN-IN TESTS (TABLES 4 AND 5)

Not applicable.

TABLE 2 - ELECTRICAL MEASUREMENTS AT ROOM TEMPERATURE

No.	Characteristics	Symbol	Spec. and/or test Method	Test Conditions	Limits		Unit
					Min.	Max.	
1	Insulation Resistance	R _i	ESCC 3402 , Para. 9.1	500 Vdc	5000	-	MΩ
2	Voltage Proof Leakage Current	I _L	ESCC 3402 , Para. 9.2	See Figure 2(b)	-	2	mA

TABLES 3, 4 AND 5

Not applicable.

4.8 ENVIRONMENTAL AND ENDURANCE TESTS (CHARTS IV AND V OF ESCC GENERIC SPECIFICATION NO. [3402](#))

4.8.1 Measurements and Inspections on Completion of Environmental Tests

The parameters to be measured on completion of environmental tests are scheduled in Table 6 of this specification. Unless otherwise stated, the measurements shall be performed at $T_{amb} = +22 \pm 3^\circ\text{C}$.

4.8.2 Measurements and Inspections at Intermediate Points during Endurance Tests

Not applicable.

4.8.3 Measurements and Inspections on Completion of Endurance Tests

The parameters to be measured on completion of endurance tests are scheduled in Table 6 of this specification. Unless otherwise stated, the measurements shall be performed at $T_{amb} = +22 \pm 3^{\circ}\text{C}$.

4.8.4 Conditions for Operating Life Tests (Part of Endurance Testing)

Not applicable.

4.8.5 Electrical Circuits for Operating Life Tests

Not applicable.

4.8.6 Conditions for High Temperature Storage Test (Part of Endurance Testing)

The requirements for the high temperature storage test are specified in Section 9 of ESCC Generic Specification No. [3402](#). The conditions for high temperature storage shall be the maximum operating temperature as specified in Figure 2(b).

TABLE 6 - MEASUREMENTS AND INSPECTIONS ON COMPLETION OF ENVIRONMENTAL AND ENDURANCE TESTS

No.	ESCC Generic Spec. No. 3402		Measurements and Inspections		Symbol	Limits		Units
	Environmental and Endurance Tests (1)	Test Method and Conditions	Identification	Conditions		Min.	Max.	
01	Coupling Proof Torque	Para. 9.4	Final Measurements Interface Dimensions Visual Examination	- Para 9.4 of ESCC 3402	- -	Figure 2(a)		- -
02	Mating and Unmating Forces	Para. 9.5	During Test Torque	Para. 4.3.5 of this spec	-	-	24	N.cm
03	Seal Test	Para. 9.7	Hermeticity Leakage	If applicable As applicable	- -	-	1.10 ⁻⁸ No Bubbles	cm ³ /s -
04	External Visual Inspection	Para. 9.8	External Visual Inspection	Para. 9.8 of ESCC 3402	-	-	-	-
05	Contact Resistance	Para. 9.9 6V 10mA	During Test Contact Resistance	Centre Contact Shell Hermetic Centre Contact	- - -	-	3 2 10	mΩ mΩ mΩ
06	Vibration	Para 9.10 Full Engagement	During Test Electrical Measurements Final Measurements Visual Examination Contact Resistance	Last Cycle in each direction No open or short circuits No evidence of damage Centre Contact (6V 10mA)	- - - -	-	- - 3	- - mΩ
07	Shock or Bump	Para. 9.11 Full Engagement	Final Measurements Visual Examination Contact Resistance	No evidence of damage Centre Contact (6V 10mA)	- -	-	- 3	- mΩ
08	Rapid Change of Temperature	Para. 9.12	Final Measurements Contact Resistance Voltage Proof Leakage Current Visual Examination	After a recovery period of 24 ±2hrs Centre Contact (6V 10mA) Table 2 Item 2 -	- I _L -	-	3 Table 2 Item 2 -	mΩ - -
09	Climatic Sequence	Para. 9.13	During Test Voltage Proof Final Measurements External Visual Inspection Insulation Resistance Voltage Proof Leakage Current	At Low Air Pressure 0.1X Value of Figure 2(b) After Final Damp Heat cycle (within 1 to 24 hrs recovery) Para. 9.8 of ESCC 3402 Table 2 Item 1 Table 2 item 2	VP - Ri I _L	No flashover or breakdown -	- -	- MΩ Table 2 item 2
10	Cable Retention Force	Para. 9.14 and Para. 4.3.4 of this spec	Not applicable					

No.	ESCC Generic Spec. No. 3402		Measurements and Inspections		Symbol	Limits		Units
	Environmental and Endurance Tests (1)	Test Method and Conditions	Identification	Conditions		Min.	Max.	
11	Cabling and Crimping Capability	Para. 9.15	Not applicable					
12	VSWR or Reflection Coefficient	Para. 9.16	VSWR	Para. 9.16 of ESCC 3402	-	Figure 2(b)		-
13	Corona Level	Para. 9.17	Corona	Para. 9.17 of ESCC 3402	-	Figure 2(b)		-
14	Endurance	Para 9.18 and Para. 4.3.6 of this spec.	Final Measurements					
			Mating/Unmating Forces	Para. 4.3.5 of this spec.	-	-	24	N.cm
			Contact Resistance	Centre Contact (6V 10mA)	-	-	4	mΩ
				Shell (6V 10mA)	-	-	3	mΩ
				Hermetic Centre Contact (6V 10mA)	-	-	12	mΩ
	Visual Examination	Para. 9.18 of ESCC 3402		-	-	-	-	
15	RF Insertion Loss	Para. 9.19	Insertion Loss	Para. 9.19 of ESCC 3402	-	Figure 2(b)		-
16	Corrosion	Para. 9.20	Visual Examination	Para. 9.20 of ESCC 3402 No exposure of base metal	-	-	-	-
17	Residual Magnetism	Para. 9.21	Magnetism	-	-	Para. 4.3.7		-
18	Soldering Proof	Para. 9.22	Not applicable					
19	RF Leakage	Para. 9.23	Leakage	-	-	Figure 2(b)		-
20	High Temperature Storage	Para. 9.24 and Para. 4.8.6 of this spec.	Final Measurements					
			Mating/Unmating Forces	Para. 4.3.5 of this spec.	-	-	24	N.cm
			Insulation Resistance	Table 2 Item 1	R _i	5000	-	MΩ
			Voltage Proof Leakage Current	Table 2 item 2	I _L	Table 2 item 2		-
			Contact Retention	Para. 4.3.9 of this spec.	-	Para. 4.3.9		-
			Visual Examination	-	-	-	-	-
			Contact Resistance	Centre Contact (6V 10mA)	-	-	8	mΩ
				Shell (6V 10mA)	-	-	7.5	mΩ
	Hermetic Centre Contact (6V 10mA)	-	-	15	mΩ			
	External Visual Inspection	Para. 9.8 of ESCC 3402		-	-	-	-	
21	Permanence of Marking	Para. 9.27	Marking Permanence	Para. 9.27 of ESCC 3402	-	-	-	-
22	Plating Thickness (Hermetic Types Only)	Para. 9.29	Plating Thickness	Para. 5.3.4 of ESCC 3402	-	-	-	-

NOTES

1. The tests in this Table refer to either Chart IV or V and shall be used as applicable.

FIGURE 2(b) – VARIANTS

VARIANT 01 - STRAIGHT ADAPTOR, MALE - MALE

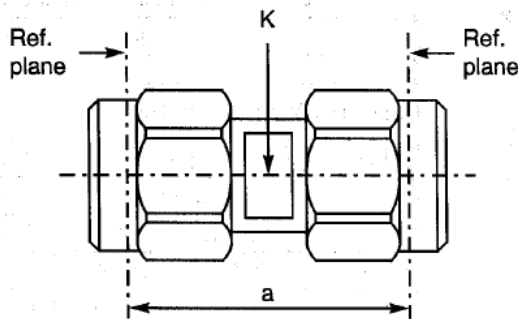

Symbol	Millimetres		Notes
	Min.	Max.	
a	14.9	15.1	
K	-	5.5	2 flats

ELECTRICAL CHARACTERISTICS	VALUES	UNITS
Frequency range	0 to 18	GHz
Maximum voltage standing wave ratio (VSWR)	$1.1 + 0.008 f$ (GHz)	
Maximum reflection coefficient	$0.047 + 0.0034 f$ (GHz)	
Maximum insertion loss	$0.06 \sqrt{f}$ (GHz)	dB
RF leakage	$-[95 - f]$ (GHz)	dB
Voltage proof	1000	Vrms
Corona level	Not applicable	Vrms

MECHANICAL CHARACTERISTICS	VALUES	UNITS
Mini centre contact retention force (axial)	27	N
Mini centre contact retention torque	Not applicable	N.cm
Mini cable retention force	Not applicable	N
Mini cable retention torque value	Not applicable	N.cm
Maximum weight	4.9	g

OTHER CHARACTERISTICS	VALUES	UNITS
Rapid change of temperature - peak value	+115	°C
Operating temperature range	-65 to + 105	°C
Maxi leakage (panel sealed connectors)	Not applicable	
Maxi leakage (hermetic sealed connector)	Not applicable	
Solderability	Not applicable	
Soldering proof	Not applicable	
Cables used	Not applicable	

FIGURE 2(b) – VARIANTS (CONTINUED)

VARIANT 02 - STRAIGHT ADAPTOR, MALE - FEMALE

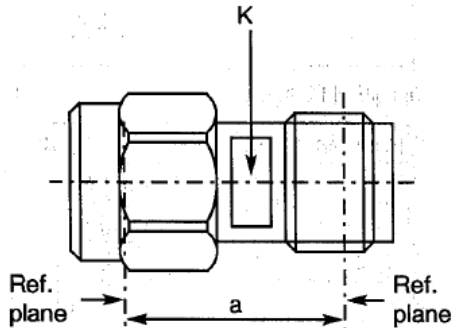

Symbol	Millimetres		Notes
	Min.	Max.	
a	12.4	12.65	
K	5.4	5.5	2 flats

ELECTRICAL CHARACTERISTICS	VALUES	UNITS
Frequency range	0 to 18	GHz
Maximum voltage standing wave ratio (VSWR)	$1.1 + 0.008 f$ (GHz)	
Maximum reflection coefficient	$0.047 + 0.0034 f$ (GHz)	
Maximum insertion loss	$0.06 \sqrt{f}$ (GHz)	dB
RF leakage	$-[95 - f]$ (GHz)	dB
Voltage proof	1000	Vrms
Corona level	Not applicable	Vrms

MECHANICAL CHARACTERISTICS	VALUES	UNITS
Mini centre contact retention force (axial)	27	N
Mini centre contact retention torque	Not applicable	N.cm
Mini cable retention force	Not applicable	N
Mini cable retention torque value	Not applicable	N.cm
Maximum weight	3.5	g

OTHER CHARACTERISTICS	VALUES	UNITS
Rapid change of temperature - peak value	+115	°C
Operating temperature range	-65 to +105	°C
Maxi leakage (panel sealed connectors)	Not applicable	
Maxi leakage (hermetic sealed connector)	Not applicable	
Solderability	Not applicable	
Soldering proof	Not applicable	
Cables used	Not applicable	

FIGURE 2(b) – VARIANTS (CONTINUED)

VARIANT 03 - STRAIGHT ADAPTOR, FEMALE - FEMALE

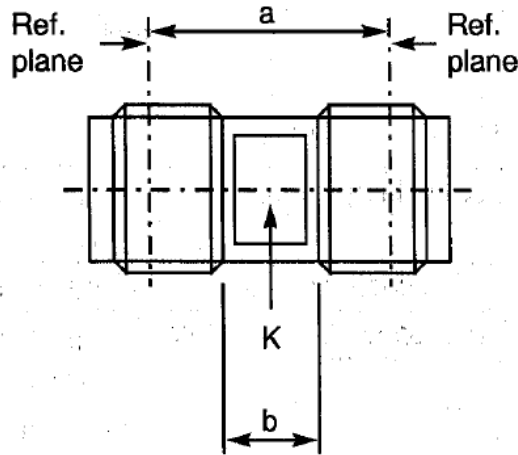

Symbol	Millimetres		Notes
	Min.	Max.	
a	10.1	10.3	
b	4.4	-	
K	5.4	5.5	2 flats

ELECTRICAL CHARACTERISTICS	VALUES	UNITS
Frequency range	0 to 18	GHz
Maximum voltage standing wave ratio (VSWR)	$1.1 + 0.008 f$ (GHz)	
Maximum reflection coefficient	$0.047 + 0.0034 f$ (GHz)	
Maximum insertion loss	$0.06 \sqrt{f}$ (GHz)	dB
RF leakage	$- [95 - f$ (GHz)]	dB
Voltage proof	1000	Vrms
Corona level	Not applicable	Vrms

MECHANICAL CHARACTERISTICS	VALUES	UNITS
Mini centre contact retention force (axial)	27	N
Mini centre contact retention torque	Not applicable	N.cm
Mini cable retention force	Not applicable	N
Mini cable retention torque value	Not applicable	N.cm
Maximum weight	1.9	g

OTHER CHARACTERISTICS	VALUES	UNITS
Rapid change of temperature - peak value	+115	°C
Operating temperature range	-65 to +105	°C
Maxi leakage (panel sealed connectors)	Not applicable	
Maxi leakage (hermetic sealed connector)	Not applicable	
Solderability	Not applicable	
Soldering proof	Not applicable	
Cables used	Not applicable	

FIGURE 2(b) – VARIANTS (CONTINUED)

VARIANT 04 - STRAIGHT BULKHEAD ADAPTOR, FEMALE - FEMALE

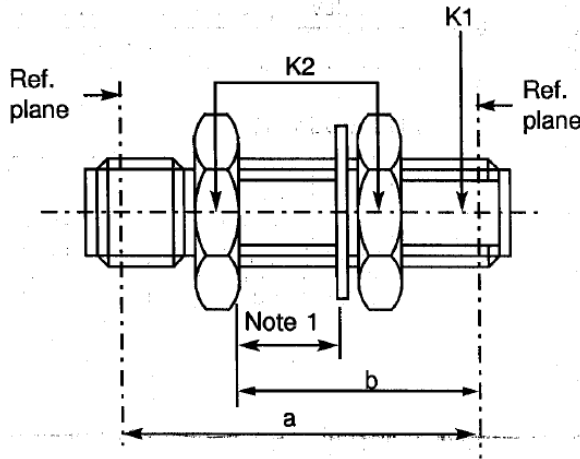

Symbol	Millimetres		Notes
	Min.	Max.	
a	-	18.4	
b	12.5	12.85	
K1	-	6	1 flat
K2	-	8	Hex.

NOTES

1. Maximum panel thickness: 6mm.

ELECTRICAL CHARACTERISTICS	VALUES	UNITS
Frequency range	0 to 18	GHz
Maximum voltage standing wave ratio (VSWR)	$1.1 + 0.008 f$ (GHz)	
Maximum reflection coefficient	$0.047 + 0.0034 f$ (GHz)	
Maximum insertion loss	$0.06 \sqrt{f}$ (GHz)	dB
RF leakage	- [95 - f (GHz)]	dB
Voltage proof	1000	Vrms
Corona level	Not applicable	Vrms

MECHANICAL CHARACTERISTICS	VALUES	UNITS
Mini centre contact retention force (axial)	27	N
Mini centre contact retention torque	Not applicable	N.cm
Mini cable retention force	Not applicable	N
Mini cable retention torque value	Not applicable	N.cm
Maximum weight	3.9	g

OTHER CHARACTERISTICS	VALUES	UNITS
Rapid change of temperature - peak value	+115	°C
Operating temperature range	-65 to +105	°C
Maxi leakage (panel sealed connectors)	Not applicable	
Maxi leakage (hermetic sealed connector)	Not applicable	
Solderability	Not applicable	
Soldering proof	Not applicable	
Cables used	Not applicable	

FIGURE 2(B) – VARIANTS (CONTINUED)
VARIANT 05 – ELBOW ADAPTOR, MALE - FEMALE

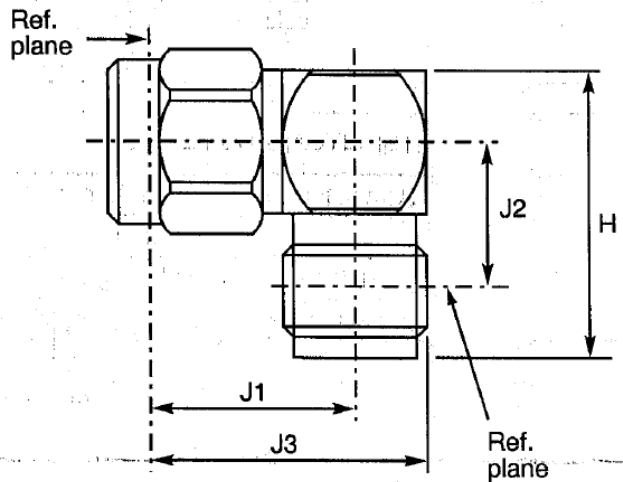

Symbol	Millimetres	
	Min.	Max.
H	14.2	15.9
J1	9.1	9.5
J2	9.1	9.5
J3	12.2	12.95

ELECTRICAL CHARACTERISTICS	VALUES	UNITS
Frequency range	0 to 12.4	GHz
Maximum voltage standing wave ratio (VSWR)	1.05 + 0.01 f (GHz)	
Maximum reflection coefficient	0.024 + 0.004 f (GHz)	
Maximum insertion loss	0.05 √f (GHz)	dB
RF leakage (1)	-[95 - f (GHz)]	dB
Voltage proof	1000	Vrms
Corona level	Not applicable	Vrms

NOTES:

- For information only.

MECHANICAL CHARACTERISTICS	VALUES	UNITS
Mini centre contact retention force (axial)	27	N
Mini centre contact retention torque	2.8	N.cm
Mini cable retention force	Not applicable	N
Mini cable retention torque value	Not applicable	N.cm
Maximum weight	4.9	g

OTHER CHARACTERISTICS	VALUES	UNITS
Rapid change of temperature - peak value	+200	°C
Operating temperature range	-65 to +105	°C
Maxi leakage (panel sealed connectors)	Not applicable	
Maxi leakage (hermetic sealed connector)	Not applicable	
Solderability	Not applicable	
Soldering proof	Not applicable	
Cables used	Not applicable	

FIGURE 2(b) – VARIANTS (CONTINUED)
VARIANT 06 – T-ADAPTOR, FEMALE – FEMALE/MALE

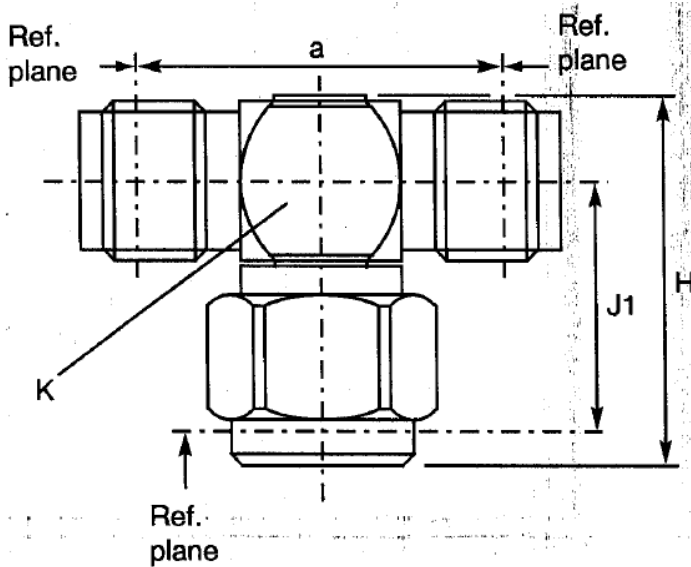

Symbol	Millimetres		Notes
	Min.	Max.	
a	14.09	14.2	
H	15.7	16.75	
J1	9.75	10	
K	-	7	Across flat

ELECTRICAL CHARACTERISTICS	VALUES	UNITS
Frequency range	0 to 12.4	GHZ
Maximum voltage standing wave ratio (VSWR)	Not applicable	
Maximum reflection coefficient	Not applicable	
Maximum insertion loss	Not applicable	dB
RF leakage	Not applicable	dB
Voltage proof	1000	Vrms
Corona level	Not applicable	Vrms

MECHANICAL CHARACTERISTICS	VALUES	UNITS
Mini centre contact retention force (axial)	27	N
Mini centre contact retention torque	2.8	N.cm
Mini cable retention force	Not applicable	N
Mini cable retention torque value	Not applicable	N.cm
Maximum weight	5.9	g

OTHER CHARACTERISTICS	VALUES	UNITS
Rapid change of temperature - peak value	+200	°C
Operating temperature range	-65 to +165	°C
Maxi leakage (panel sealed connectors)	Not applicable	
Maxi leakage (hermetic sealed connector)	Not applicable	
Solderability	Not applicable	
Soldering proof	Not applicable	
Cables used	Not applicable	

FIGURE 2(b) – VARIANTS (CONTINUED)

VARIANT 07 – HERMETIC ADAPTOR, FEMALE - FEMALE

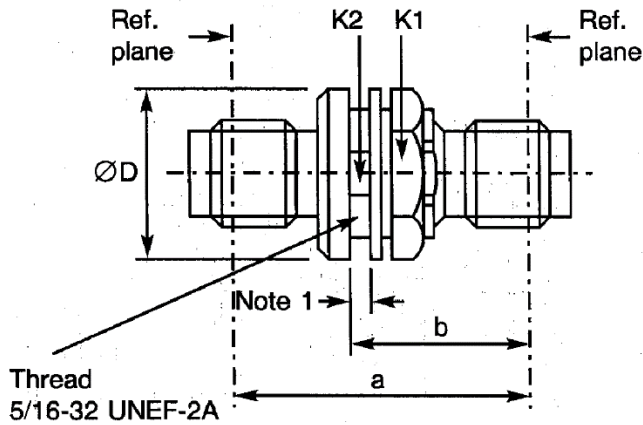

Symbol	Millimetres		Notes
	Min.	Max.	
a	18.5	18.9	
b	11.7	13.2	
ØD	12.9	14.2	
K1	-	10	Hex.
K2	-	7.5	1 flat

NOTES

- Maximum panel thickness: 4.3mm.

ELECTRICAL CHARACTERISTICS	VALUES	UNITS
Frequency range	0 to 12.4	GHz
Maximum voltage standing wave ratio (VSWR)	$1.1 + 0.015 f$ (GHz)	
Maximum reflection coefficient	$0.047 + 0.0063 f$ (GHz)	
Maximum insertion loss	$0.15 \sqrt{f}$ (GHz)	dB
RF leakage	- [95 - f (GHz)]	dB
Voltage proof	1000	Vrms
Corona level	Not applicable	Vrms

MECHANICAL CHARACTERISTICS	VALUES	UNITS
Mini centre contact retention force (axial)	Not applicable	N
Mini centre contact retention torque	Not applicable	N.cm
Mini cable retention force	Not applicable	N
Mini cable retention torque value	Not applicable	N.cm
Maximum weight	6.5	g

OTHER CHARACTERISTICS	VALUES	UNITS
Rapid change of temperature - peak value	+200	°C
Operating temperature range	-40 to +165	°C
Maxi leakage (panel sealed connectors)	Not applicable	
Maxi leakage (hermetic sealed connector)	Applicable	
Solderability	Applicable	
Soldering proof	Not applicable	
Cables used	Not applicable	

FIGURE 2(b) – VARIANTS (CONTINUED)

VARIANT 08 – T-ADAPTOR, FEMALE – FEMALE/FEMALE

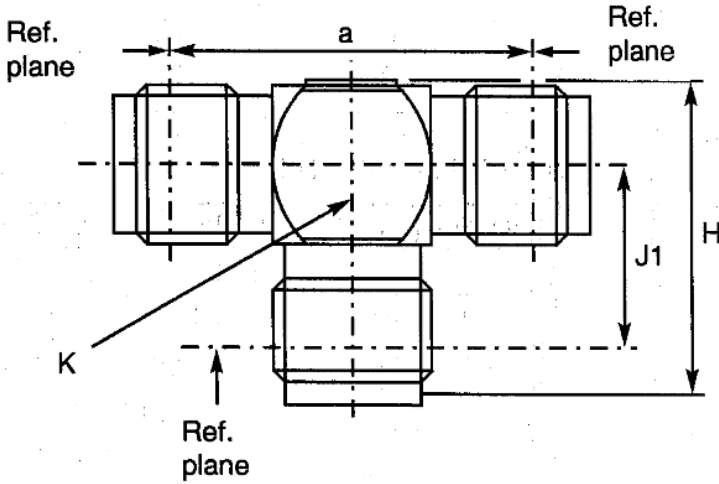

Symbol	Millimetres		Notes
	Min.	Max.	
a	14	14.2	
H	13.25	13.65	
J1	7.9	8.2	
K	-	7	2 flats

ELECTRICAL CHARACTERISTICS	VALUES	UNITS
Frequency range	0 to 12.4	GHz
Maximum voltage standing wave ratio (VSWR)	Not applicable	
Maximum reflection coefficient	Not applicable	
Maximum insertion loss	Not applicable	dB
RF leakage	Not applicable	dB
Voltage proof	1000	Vrms
Corona level	Not applicable	Vrms

MECHANICAL CHARACTERISTICS	VALUES	UNITS
Mini centre contact retention force (axial)	27	N
Mini centre contact retention torque	Not applicable	N.cm
Mini cable retention force	Not applicable	N
Mini cable retention torque value	Not applicable	N.cm
Maximum weight	5.9	g

OTHER CHARACTERISTICS	VALUES	UNITS
Rapid change of temperature - peak value	+200	°C
Operating temperature range	-65 to +165	°C
Maxi leakage (panel sealed connectors)	Not applicable	
Maxi leakage (hermetic sealed connector)	Not applicable	
Solderability	Not applicable	
Soldering proof	Not applicable	
Cables used	Not applicable	

FIGURE 2(b) – VARIANTS (CONTINUED)

VARIANT 09 – STRAIGHT FLANGE ADAPTOR, MALE - FEMALE

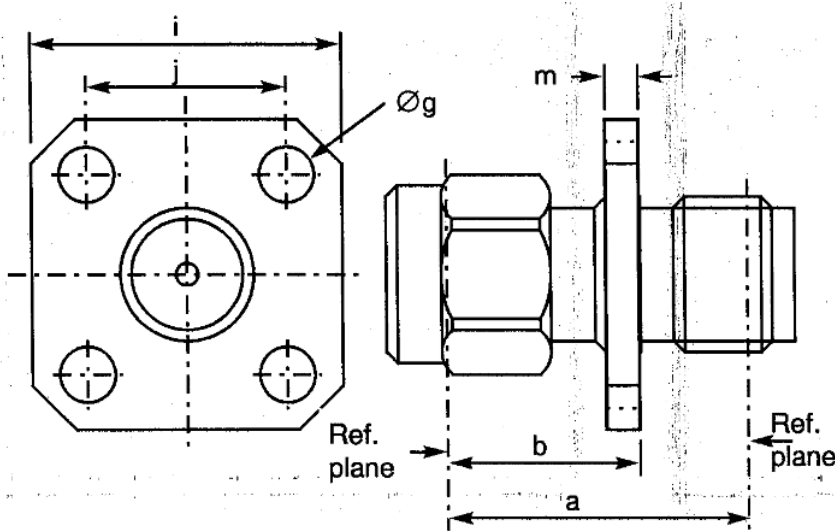

Symbol	Millimetres		Notes
	Min.	Max.	
a	17.05	17.1	
b	9.45	9.55	
Øg	2.55	2.7	4 holes
i	12.6	12.8	
j	8.59	8.69	
m	1.4	1.8	

ELECTRICAL CHARACTERISTICS	VALUES	UNITS
Frequency range	0 to 18	GHz
Maximum voltage standing wave ratio (VSWR)	$1.1 + 0.008 f$ (GHz)	
Maximum reflection coefficient	$0.047 + 0.0034 f$ (GHz)	
Maximum insertion loss	$0.06 \sqrt{f}$ (GHz)	dB
RF leakage	- [95 - f (GHz)]	dB
Voltage proof	1000	Vrms
Corona level	Not applicable	Vrms

MECHANICAL CHARACTERISTICS	VALUES	UNITS
Mini centre contact retention force (axial)	27	N
Mini centre contact retention torque	Not applicable	N.cm
Mini cable retention force	Not applicable	N
Mini cable retention torque value	Not applicable	N.cm
Maximum weight	3.3	g

OTHER CHARACTERISTICS	VALUES	UNITS
Rapid change of temperature - peak value	+115	°C
Operating temperature range	-65 to +105	°C
Maxi leakage (panel sealed connectors)	Not applicable	
Maxi leakage (hermetic sealed connector)	Not applicable	
Solderability	Not applicable	
Soldering proof	Not applicable	
Cables used	Not applicable	

FIGURE 2(b) – VARIANTS (CONTINUED)

VARIANT 10 - STRAIGHT FLANGE ADAPTOR, FEMALE - FEMALE

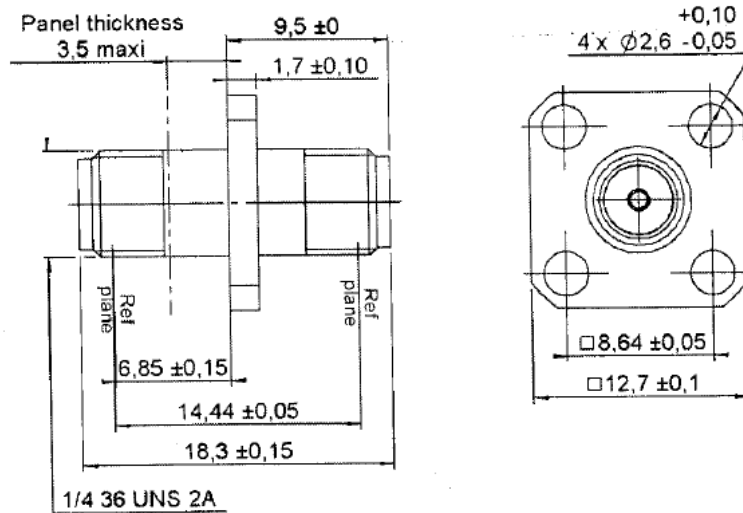

NOTES

1. All dimensions are in millimetres.

ELECTRICAL CHARACTERISTICS	VALUES	UNITS
Frequency range	0 to 12.4	GHz
Maximum voltage standing wave ratio (VSWR)	1.1 + 0.08 f (GHz)	
Maximum reflection coefficient	0.047 + 0.0034 f (GHz)	
Maximum insertion loss	0.06 √f (GHz)	dB
RF leakage	- [95 - f (GHz)]	dB
Voltage proof	1000	Vrms
Corona level	Not applicable	Vrms

MECHANICAL CHARACTERISTICS	VALUES	UNITS
Mini centre contact retention force (axial)	27	N
Mini centre contact retention torque	Not applicable	N.cm
Mini cable retention force	Not applicable	N
Mini cable retention torque value	Not applicable	N.cm
Maximum weight	4.2	g

OTHER CHARACTERISTICS	VALUES	UNITS
Rapid change of temperature - peak value	+180	°C
Operating temperature range	-65 to +165	°C
Maxi leakage (panel sealed connectors)	Not applicable	
Maxi leakage (hermetic sealed connector)	Not applicable	
Solderability	Not applicable	
Soldering proof	Not applicable	
Cables used	Not applicable	

FIGURE 2(b) - VARIANTS (CONTINUED)

VARIANT 11 - STRAIGHT ADAPTOR, MALE - MALE

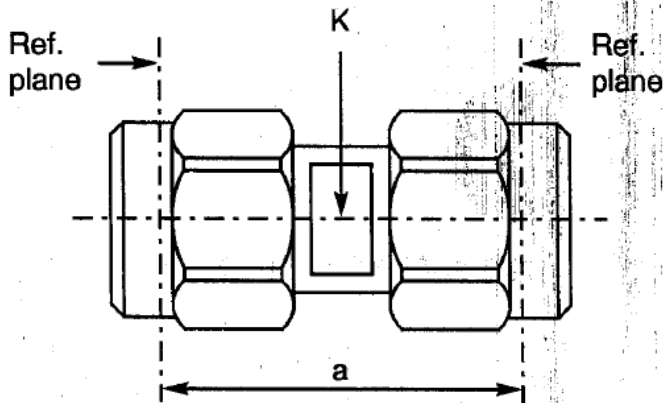

Symbol	Millimetres		Notes
	Min.	Max.	
a	14.9	15.1	
K	-	5.5	2 flats

ELECTRICAL CHARACTERISTICS	VALUES	UNITS
Frequency range	0 to 18	GHz
Maximum voltage standing wave ratio (VSWR)	$1.1 + 0.008 f$ (GHz)	
Maximum reflection coefficient	$0.047 + 0.0034 f$ (GHz)	
Maximum insertion loss	$0.06 \sqrt{f}$ (GHz)	dB
RF leakage	- [95 - f (GHz)]	dB
Voltage proof	1000	Vrms
Corona level	Not applicable	Vrms

MECHANICAL CHARACTERISTICS	VALUES	UNITS
Mini centre contact retention force (axial)	27	N
Mini centre contact retention torque	Not applicable	N.cm
Mini cable retention force	Not applicable	N
Mini cable retention torque value	Not applicable	N.cm
Maximum weight	4.9	g

OTHER CHARACTERISTICS	VALUES	UNITS
Rapid change of temperature - peak value	+180	°C
Operating temperature range	-65 to +165	°C
Maxi leakage (panel sealed connectors)	Not applicable	
Maxi leakage (hermetic sealed connector)	Not applicable	
Solderability	Not applicable	
Soldering proof	Not applicable	
Cables used	Not applicable	

FIGURE 2(b) - VARIANTS (CONTINUED)

VARIANT 12 - STRAIGHT ADAPTOR, MALE - FEMALE

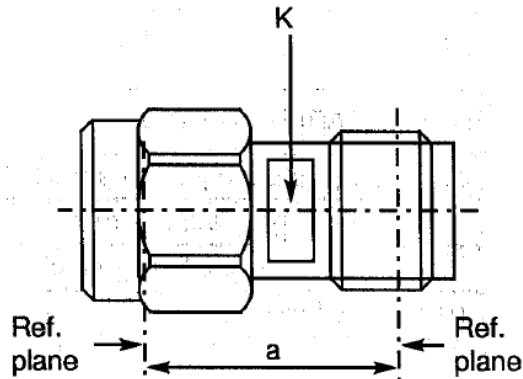

Symbol	Millimetres		Notes
	Min.	Max.	
a	12.4	12.65	
K	5.4	5.5	2 flats

ELECTRICAL CHARACTERISTICS	VALUES	UNITS
Frequency range	0 to 18	GHz
Maximum voltage standing wave ratio (VSWR)	$1.1 + 0.008 f$ (GHz)	
Maximum reflection coefficient	$0.047 + 0.0034 f$ (GHz)	
Maximum insertion loss	$0.06 \sqrt{f}$ (GHz)	dB
RF leakage	$- [95 - f]$ (GHz)	dB
Voltage proof	1000	Vrms
Corona level	Not applicable	Vrms

MECHANICAL CHARACTERISTICS	VALUES	UNITS
Mini centre contact retention force (axial)	27	N
Mini centre contact retention torque	Not applicable	N.cm
Mini cable retention force	Not applicable	N
Mini cable retention torque value	Not applicable	N.cm
Maximum weight	3.5	g

OTHER CHARACTERISTICS	VALUES	UNITS
Rapid change of temperature - peak value	+180	°C
Operating temperature range	-65 to +165	°C
Maxi leakage (panel sealed connectors)	Not applicable	
Maxi leakage (hermetic sealed connector)	Not applicable	
Solderability	Not applicable	
Soldering proof	Not applicable	
Cables used	Not applicable	

FIGURE 2(b) - VARIANTS (CONTINUED)

VARIANT 13 - STRAIGHT ADAPTOR, FEMALE - FEMALE

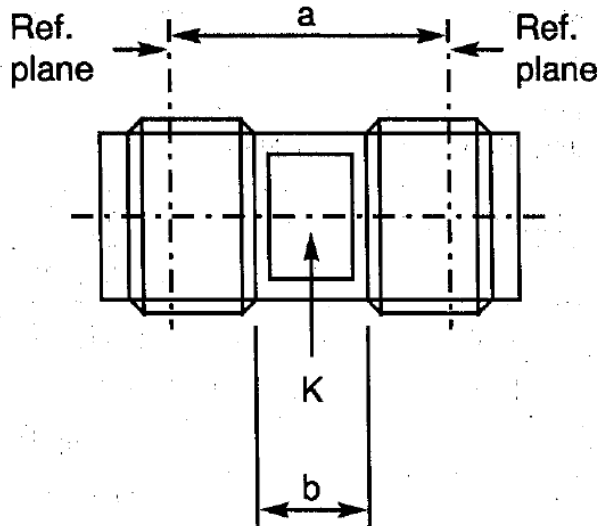

Symbol	Millimetres		Notes
	Min.	Max.	
a	10.1	10.3	
b	4.4	-	
k	5.4	5.5	2 flats

ELECTRICAL CHARACTERISTICS	VALUES	UNITS
Frequency range	0 to 18	GHz
Maximum voltage standing wave ratio (VSWR)	$1.1 + 0.008 f$ (GHz)	
Maximum reflection coefficient	$0.047 + 0.0034 f$ (GHz)	
Maximum insertion loss	$0.06 \sqrt{f}$ (GHz)	dB
RF leakage	- [95 - f (GHz)]	dB
Voltage proof	1000	Vrms
Corona level	Not applicable	Vrms

MECHANICAL CHARACTERISTICS	VALUES	UNITS
Mini centre contact retention force (axial)	27	N
Mini centre contact retention torque	Not applicable	N.cm
Mini cable retention force	Not applicable	N
Mini cable retention torque value	Not applicable	N.cm
Maximum weight	1.9	g

OTHER CHARACTERISTICS	VALUES	UNITS
Rapid change of temperature - peak value	+180	°C
Operating temperature range	-65 to +165	°C
Maxi leakage (panel sealed connectors)	Not applicable	
Maxi leakage (hermetic sealed connector)	Not applicable	
Solderability	Not applicable	
Soldering proof	Not applicable	
Cables used	Not applicable	

FIGURE 2(b) - VARIANTS (CONTINUED)

VARIANT 14 - STRAIGHT BULKHEAD ADAPTOR, FEMALE - FEMALE

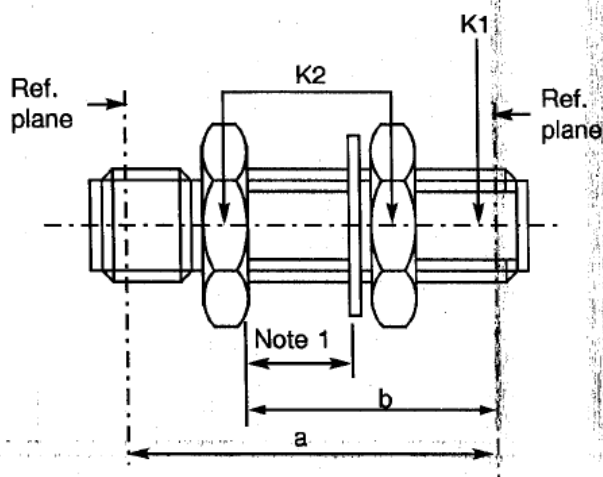

Symbol	Millimetres		Notes
	Min.	Max.	
a	-	18.4	
b	12.5	12.85	
K1	-	6	1 flat
K2	-	8	Hex.

NOTES

1. Maximum panel thickness: 6mm.

ELECTRICAL CHARACTERISTICS	VALUES	UNITS
Frequency range	0 to 18	GHz
Maximum voltage standing wave ratio (VSWR)	$1.1 + 0.008 f$ (GHz)	
Maximum reflection coefficient	$0.047 + 0.0034 f$ (GHz)	
Maximum insertion loss	$0.06 \sqrt{f}$ (GHz)	dB
RF leakage	- [95 - f (GHz)]	dB
Voltage proof	1000	Vrms
Corona level	Not applicable	Vrms

MECHANICAL CHARACTERISTICS	VALUES	UNITS
Mini centre contact retention force (axial)	27	N
Mini centre contact retention torque	Not applicable	N.cm
Mini cable retention force	Not applicable	N
Mini cable retention torque value	Not applicable	N.cm
Maximum weight	3.9	g

OTHER CHARACTERISTICS	VALUES	UNITS
Rapid change of temperature - peak value	+180	°C
Operating temperature range	-65 to +165	°C
Maxi leakage (panel sealed connectors)	Not applicable	
Maxi leakage (hermetic sealed connector)	Not applicable	
Solderability	Not applicable	
Soldering proof	Not applicable	
Cables used	Not applicable	