



**CAPACITORS, VARIABLE, CONCENTRIC
TRIMMER, SAPPHIRE DIELECTRIC, 0.3 TO 1.2pF,
BODY DIAMETER 1.9mm**

ESCC Detail Specification No. 3010/017

Issue 3	July 2018
---------	-----------



LEGAL DISCLAIMER AND COPYRIGHT

European Space Agency, Copyright © 2018. All rights reserved.

The European Space Agency disclaims any liability or responsibility, to any person or entity, with respect to any loss or damage caused, or alleged to be caused, directly or indirectly by the use and application of this ESCC publication.

This publication, without the prior permission of the European Space Agency and provided that it is not used for a commercial purpose, may be:

- copied in whole, in any medium, without alteration or modification.
- copied in part, in any medium, provided that the ESCC document identification, comprising the ESCC symbol, document number and document issue, is removed.

DOCUMENTATION CHANGE NOTICE

(Refer to <https://escies.org> for ESCC DCR content)

DCR No.	CHANGE DESCRIPTION
1165	Specification updated to incorporate changes per DCR.

TABLE OF CONTENTS

1	GENERAL	5
1.1	SCOPE	5
1.2	APPLICABLE DOCUMENTS	5
1.3	TERMS, DEFINITIONS, ABBREVIATIONS, SYMBOLS AND UNITS	5
1.4	THE ESCC COMPONENT NUMBER AND COMPONENT TYPE VARIANTS	5
1.4.1	The ESCC Component Number	5
1.4.2	Component Type Variants	5
1.5	MAXIMUM RATINGS	6
1.6	PHYSICAL DIMENSIONS	7
1.6.1	Component Type Variants 01 and 02	7
1.6.2	Component Type Variants 03 and 04	7
1.6.3	Component Type Variants 05 and 06	8
1.6.4	Component Type Variants 07 and 08	9
1.6.5	Component Type Variants 09 and 10	9
1.6.6	Component Type Variants 11 and 12	10
1.7	FUNCTIONAL DIAGRAM	10
1.8	MATERIALS AND FINISHES	10
1.8.1	Case	10
1.8.2	Terminals	10
2	REQUIREMENTS	11
2.1	GENERAL	11
2.1.1	Deviations from the Generic Specification	11
2.1.1.1	Deviations from Qualification and Periodic Tests – Chart F4	11
2.2	MARKING	11
2.3	ROBUSTNESS OF TERMINATIONS	11
2.4	RESISTANCE TO SOLDERING HEAT	11
2.5	ELECTRICAL AND MECHANICAL MEASUREMENTS AT ROOM, HIGH AND LOW TEMPERATURES	12
2.5.1	Room Temperature Electrical and Mechanical Measurements	12
2.5.2	High and Low Temperatures Electrical Measurements	12
2.6	INTERMEDIATE AND END-POINT ELECTRICAL AND MECHANICAL MEASUREMENTS	13
2.7	BURN-IN CONDITIONS	15
2.8	OPERATING LIFE CONDITIONS	15
	APPENDIX 'A'	16

1 GENERAL

1.1 SCOPE

This specification details the ratings, physical and electrical characteristics, and test and inspection data for the component type variants specified below. It supplements the requirements of, and shall be read in conjunction with, the ESCC Generic Specification listed under Applicable Documents.

1.2 APPLICABLE DOCUMENTS

The following documents form part of this specification and shall be read in conjunction with it:

- (a) ESCC Generic Specification No. [3010](#).

1.3 TERMS, DEFINITIONS, ABBREVIATIONS, SYMBOLS AND UNITS

For the purpose of this specification, the terms, definitions, abbreviations, symbols and units specified in ESCC Basic Specification No. [21300](#) shall apply.

1.4 THE ESCC COMPONENT NUMBER AND COMPONENT TYPE VARIANTS

1.4.1 The ESCC Component Number

The ESCC Component Number shall be constituted as follows:

Example: 301001704

- Detail Specification Reference: 3010017
- Component Type Variant Number: 04 (as required)

1.4.2 Component Type Variants

The Component Type Variants applicable to this specification are as follows:

Type Variant	Minimum and Maximum Specified Capacitance (pF)		Temperature Coefficient (10 ⁻⁶ /°C)	Weight Max (g)
	Cm	CM		
01	0.3	1.2	-75 ±75	0.2
02	0.3	1.2	400 ±100	0.2
03	0.3	1.2	-75 ±75	0.2
04	0.3	1.2	400 ±100	0.2
05	0.3	1.2	-75 ±75	0.2
06	0.3	1.2	400 ±100	0.2
07	0.3	1.2	-75 ±75	0.2
08	0.3	1.2	400 ±100	0.2
09	0.3	1.2	-75 ±75	0.2
10	0.3	1.2	400 ±100	0.2
11	0.4	1.2	-75 ±75	0.2
12	0.4	1.2	400 ±100	0.2

1.5 MAXIMUM RATINGS

The maximum ratings shall not be exceeded at any time during use or storage.

Maximum ratings shall only be exceeded during testing to the extent specified in this specification and when stipulated in Test Methods and Procedures of the ESCC Generic Specification.

Characteristics	Symbols	Maximum Ratings	Units	Remarks
Rated Voltage	U_R	500	V	
Operating Temperature Range	T_{op}	-55 to +125	°C	T_{amb}
Storage Temperature Range	T_{stg}	-55 to +125	°C	
Soldering Temperature	T_{sol}	+185	°C	Note 1
Operating Torque	T_{qm}	0.8	N.cm	Note 2

NOTES:

1. Duration 5 seconds maximum.
2. Handling precautions are as follows:
 - An appropriate turning tool must be used.
 - The rotor shall not be disconnected from the stator.
 - Solvents must not be used for cleaning.

1.6 PHYSICAL DIMENSIONS

1.6.1 Component Type Variants 01 and 02

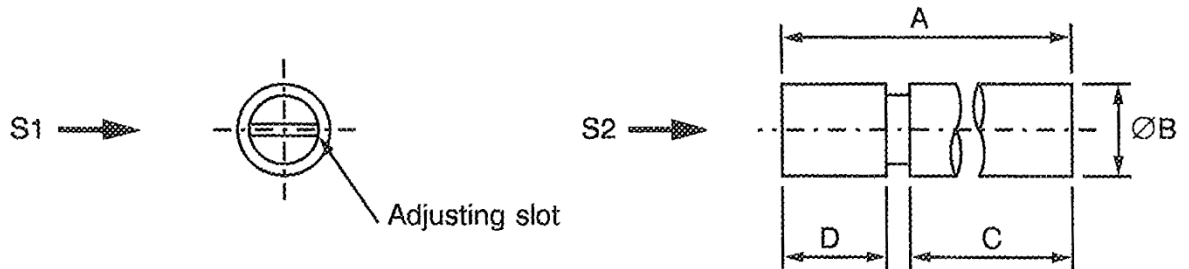

S1, S2 – Vibration and Shock axes

Symbols	Dimensions (mm)	
	Min	Max
A	5.5	6.1
ØB	-	1.9
C	3.91	4.1
D	1.2	1.4

1.6.2 Component Type Variants 03 and 04

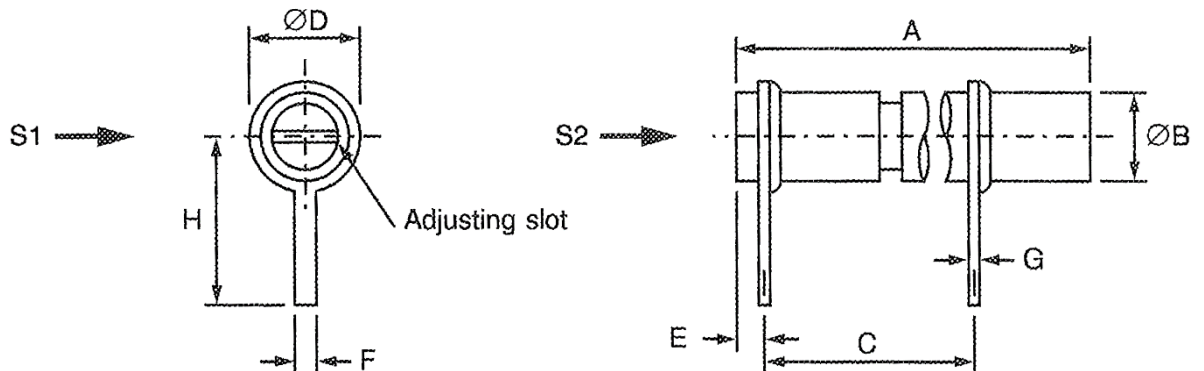

S1, S2 – Vibration and Shock axes

Symbols	Dimensions (mm)	
	Min	Max
A	5.5	6.1
ØB	-	1.9
C	1.9	2.1
ØD	-	2.5
E	0.4	0.6
F	0.95	1.05
G	0.15	0.25
H	5.6	5.8

1.6.3 Component Type Variants 05 and 06

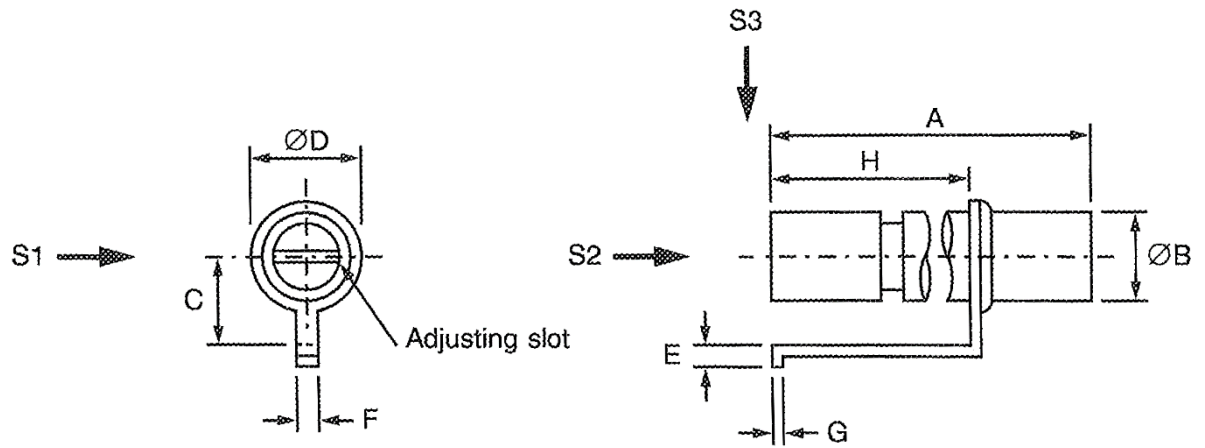

S1, S2, S3 – Vibration and Shock axes

Symbols	Dimensions (mm)	
	Min	Max
A	5.5	6.1
$\varnothing B$	-	1.9
C	1.8	2
$\varnothing D$	-	2.5
E	0.5	0.7
F	0.95	1.05
G	0.15	0.25
H	2.2	2.4

1.6.4 Component Type Variants 07 and 08

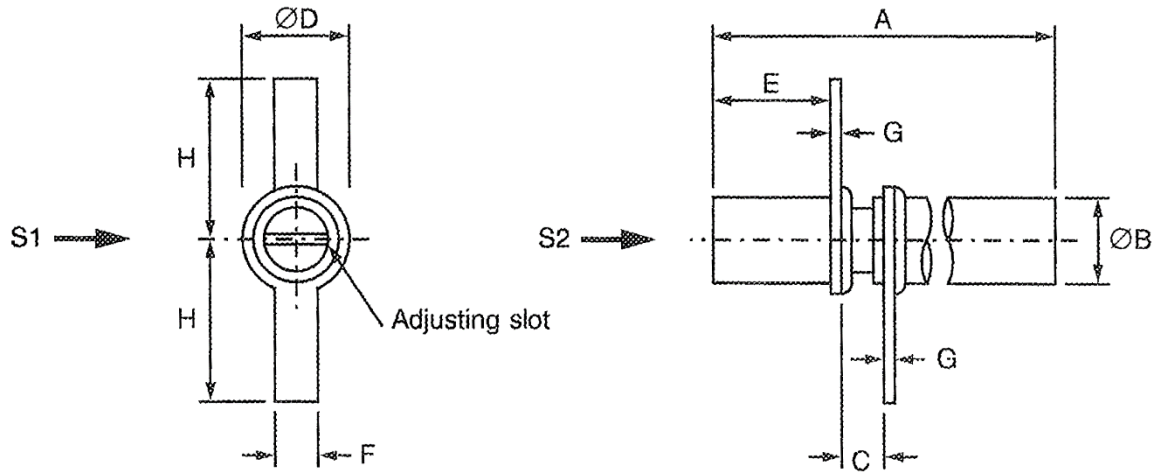

S1, S2 – Vibration and Shock axes

Symbols	Dimensions (mm)	
	Min	Max
A	5.5	6.1
ØB	-	1.9
C	1.5	1.7
ØD	-	2.5
E	0.2	0.4
F	0.95	1.05
G	0.15	0.25
H	5.6	5.8

1.6.5 Component Type Variants 09 and 10

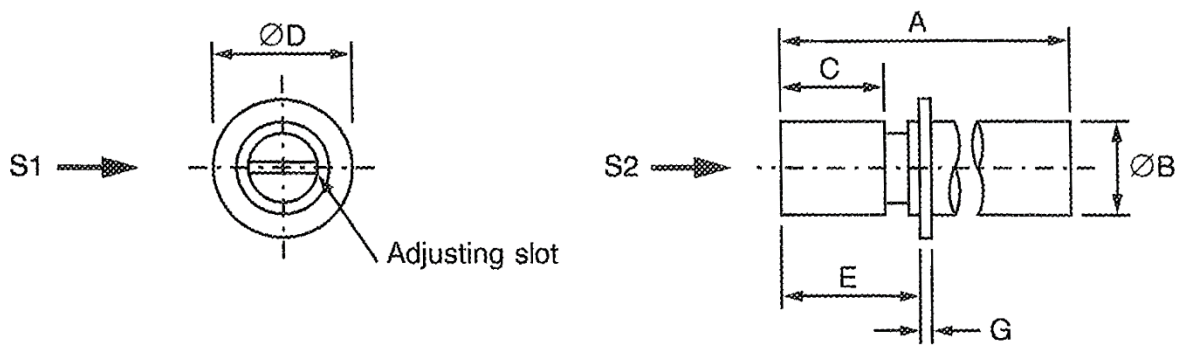

S1, S2 – Vibration and Shock axes

Symbols	Dimensions (mm)	
	Min	Max
A	5.5	6.1
ØB	-	1.9
C	1	1.2

Symbols	Dimensions (mm)	
	Min	Max
∅D	-	4.7
E	2.2	2.4
G	0.15	0.25

1.6.6 Component Type Variants 11 and 12

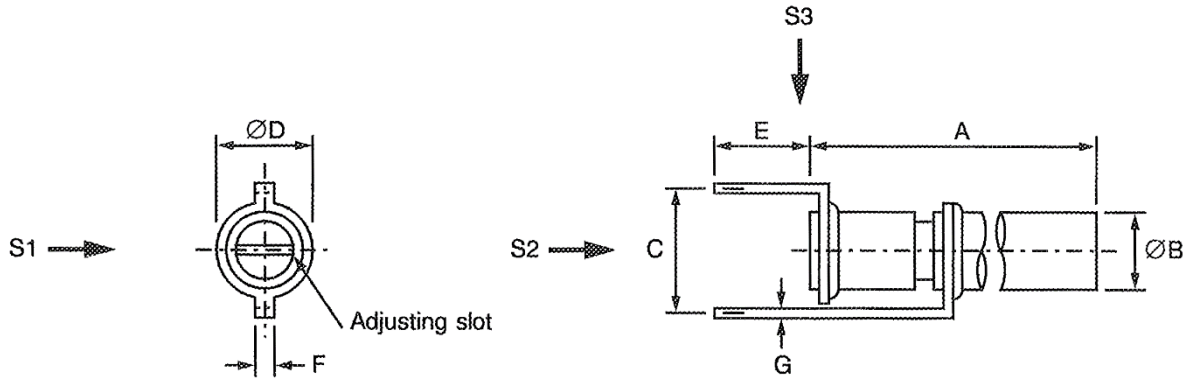

S1, S2, S3 – Vibration and Shock axes

Symbols	Dimensions (mm)	
	Min	Max
A	5.5	6.1
∅B	-	1.9
C	2.8	3.2
∅D	-	2.5
E	3.9	4.1
F	0.95	1.05
G	0.15	0.25

1.7 FUNCTIONAL DIAGRAM

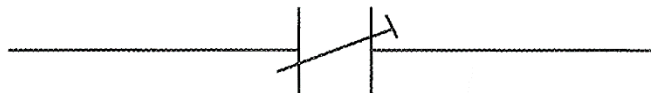

1.8 MATERIALS AND FINISHES

1.8.1 Case

The body of the components shall be sapphire.

1.8.2 Terminals

Terminals shall be gold plated or tinned.

2 REQUIREMENTS

2.1 GENERAL

The complete requirements for procurement of the components specified herein are as stated in this specification and the ESCC Generic Specification. Permitted deviations from the Generic Specification, applicable to this specification only, are listed below.

Permitted deviations from the Generic Specification and this Detail Specification, formally agreed with specific Manufacturers on the basis that the alternative requirements are equivalent to the ESCC requirement and do not affect the component's reliability, are listed in the appendices attached to this specification.

2.1.1 Deviations from the Generic Specification

2.1.1.1 *Deviations from Qualification and Periodic Tests – Chart F4*

- (a) Mechanical Endurance: The 50 cycles shall be divided into 10 groups of 5 cycles. Upon completion of each group of 5 cycles, 1 minute of standing by shall be observed.

2.2 MARKING

The marking shall be in accordance with the requirements of ESCC Basic Specification No. [21700](#) and as follows.

The information to be marked on the component or its primary package shall be:

- (a) The ESCC qualified components symbol (for ESCC qualified components only).
- (b) The ESCC Component Number.
- (c) Traceability information.

2.3 ROBUSTNESS OF TERMINATIONS

Component Type Variants 01, 02, 09 and 10 shall be subjected to Robustness of Terminations as specified in the ESCC Generic Specification.

Not applicable to Component Type Variants 03, 04, 05, 06, 07, 08, 11, 12.

2.4 RESISTANCE TO SOLDERING HEAT

The test conditions for Resistance to Soldering Heat are as follows:

- Immersion depth: To within 1mm from the body.
- Immersion time: 3.5 ±0.5 seconds.

2.5 ELECTRICAL AND MECHANICAL MEASUREMENTS AT ROOM, HIGH AND LOW TEMPERATURES

Electrical and mechanical measurements shall be performed at room, high and low temperatures.

2.5.1 Room Temperature Electrical and Mechanical Measurements

The measurements shall be performed at $T_{amb} = +22 \pm 3^{\circ}\text{C}$.

Characteristics	Symbols	Test Method and Conditions	Limits		Units
			Min	Max	
Minimum Capacitance	Cm	ESCC No. 3010 Frequency: 1 \pm 0.1MHz	-	Note 1	pF
Maximum Capacitance	CM	ESCC No. 3010 Frequency: 1 \pm 0.1MHz	Note 1	-	pF
Change in Capacitance	-	ESCC No. 3010 Frequency: 1 \pm 0.1MHz	Note 2		-
Insulation Resistance	R _i	ESCC No. 3010 Test voltage = 500 \pm 25V	10 ⁴	-	MΩ
Voltage Proof	VP	ESCC No. 3010	1000	-	V
Quality Factor	Q	ESCC No. 3010 Frequency: 250 \pm 5MHz Note 3	5000	-	-
Operating Torque	T _{qo}	ESCC No. 3010 C minimum to maximum	0.07	0.5	N.cm

NOTES:

1. See Para. 1.4.2.
2. The rate of change in capacitance as a function of the change in adjustment shall not change sign over the entire range of adjustment.
3. For Screening Tests, Quality Factor shall be performed on a randomly selected sample of 3 components with no failures allowed.

2.5.2 High and Low Temperatures Electrical Measurements

Characteristics	Symbols	Test Method and Conditions (Note 1)	Limits		Units
			Min	Max	
Insulation Resistance	R _i	ESCC No. 3010 Test voltage = 500 \pm 25V $T_{amb} = +125 (+0 -3)^{\circ}\text{C}$	10 ³	-	MΩ
Temperature Coefficient	TC	ESCC No. 3010 Note 2 Between -55°C and +22°C Between +22°C and +125°C	Note 3 Note 3		10 ⁻⁶ /°C

NOTES:

1. Measurements shall be performed on a sample of 5 components from each manufacturing lot with 0 failures allowed. In the event of any failure a 100% inspection may be performed.
2. Rotor set at approximately 75% of the maximum specified capacitance value and components may be connected in parallel so that a minimum of 7pF is obtained for this test.
3. See Para. 1.4.2.

2.6 INTERMEDIATE AND END-POINT ELECTRICAL AND MECHANICAL MEASUREMENTS

Unless otherwise specified, the measurements shall be performed at $T_{amb} = +22 \pm 3^{\circ}C$.

Unless otherwise specified the test methods and test conditions shall be as per the corresponding test defined in Para. 2.5.1, Room Temperature Electrical and Mechanical Measurements.

Test Reference per ESCC No. 3010	Characteristics	Symbols	Limits		Units
			Min	Max	
Rapid Change of Temperature Initial Measurements	Capacitance	CM & Cm	Note 1		pF
	Final Measurements	CM & Cm	Note 1		pF
	Capacitance Drift	ΔCM & ΔCm	-0.05	+0.05	pF
Vibration Initial Measurements	Capacitance (Note 2)	C	Record Values		pF
	Final Measurements	C	Record Values		pF
	Capacitance Drift	ΔC	-0.05	+0.05	pF
Shock Initial Measurements	Capacitance (Note 2)	C	Record Values		pF
	Final Measurements	C	Record Values		pF
	Capacitance Drift	ΔC	-0.05	+0.05	pF
Resistance to Soldering Heat Initial Measurements	Capacitance (Note 2)	C	Record Values		pF
	Final Measurements	C	Record Values		pF
	Capacitance Drift	ΔC	-0.05	+0.05	pF
	Voltage Proof	VP	Note 3	-	V
	Quality Factor	Q	Note 3	-	-
Climatic Sequence Initial Measurements	Capacitance (Note 2)	C	Record Values		pF
	Final Measurements	C	Record Values		pF
	Capacitance Drift	ΔC	-0.05	+0.05	pF
	Quality Factor	Q	Note 3	-	-
	Insulation Resistance	R_i	10^3	-	M Ω
	Voltage Proof	VP	Note 3	-	V
	Operating Torque	T_{q0}	Note 3		N.cm
Damp Heat, Steady State (Note 4) Initial Measurements	Capacitance	CM & Cm	Note 1		pF

Test Reference per ESCC No. 3010	Characteristics	Symbols	Limits		Units
			Min	Max	
Damp Heat, Steady State Final Measurements	Capacitance	CM & Cm	Note 1		pF
	Capacitance Drift	Δ CM & Δ Cm	-0.05	+0.05	pF
	Quality Factor	Q	Note 3	-	-
	Insulation Resistance	R _i CM & R _i Cm	10 ³	-	MΩ
	Voltage Proof	VP	Note 3	-	V
	Operating Torque	T _{qo}	Note 3		N.cm
Operating Life Initial Measurements Intermediate Measurements (500 hours) (Note 5) (500 and 1000 hours) (Note 6) Final Measurements (1000 or 2000 hours) (Note 7)	Capacitance	CM	Note 1	-	pF
	Capacitance	CM	Note 1	-	pF
	Capacitance Drift	Δ CM	-0.05	+0.05	pF
	Insulation Resistance	R _i CM	Note 3	-	MΩ
	Voltage Proof	VP	Note 3	-	V
	Quality Factor	Q	Note 3	-	-
	Operating Torque	T _{qo}	Note 3		N.cm
	Capacitance	CM	Note 1	-	pF
	Capacitance Drift	Δ CM	-0.05	+0.05	pF
	Insulation Resistance	R _i CM	Note 3	-	MΩ
	Voltage Proof	VP	Note 3	-	V
	Quality Factor	Q	Note 3	-	-
	Operating Torque	T _{qo}	Note 3		N.cm
Axial Thrust (Note 8) Initial Measurements Measurements during Test	Capacitance (Note 2)	C	Record Values		pF
	Capacitance (Note 2)	C	Record Values		pF
	Capacitance Drift	Δ C	-0.05	+0.05	pF
Mechanical Endurance Measurements after Mechanical Endurance Cycling Final Measurements	Voltage Proof	VP	Note 3	-	V
	Change in Capacitance versus Rotation	-	Deviation \pm 10% max. (Note 9)		-
	Operating Torque	T _{qo}	0.03	0.7	N.cm
	Insulation Resistance (between rotor screw and mounting base)	R _i	Note 3	-	MΩ
Quality Factor	Q	Note 3	-	-	

Test Reference per ESCC No. 3010	Characteristics	Symbols	Limits		Units
			Min	Max	
Electrical and Mechanical Measurements	Minimum Capacitance	Cm	-	Note 1	pF
	Maximum Capacitance	CM	Note 1	-	pF
	Change in Capacitance	-	Note 3		-
	Insulation Resistance	R _i	Note 3	-	MΩ
	Voltage Proof	VP	Note 3	-	V
	Quality Factor	Q	Note 3	-	-
	Operating Torque	T _{qo}	Note 3		N.cm
Temperature Coefficient (Note 2)	Between -55°C and +22°C Between +22°C and +125°C	TC	Note 1 Note 1		10 ⁻⁶ /°C
End-Stop Torque (Note 10) Final Measurements	Minimum Capacitance Maximum Capacitance	Cm CM	- Note 1	Note 1 -	pF pF

NOTES:

1. As specified in Para. 1.4.2.
2. Measurements shall be made with the rotor set at approximately 75% of the maximum specified capacitance value.
3. As specified in Para. 2.5.1.
4. Half the sample shall be measured with U_R applied and the remaining components shall be measured with no U_R applied.
5. 500 hours is applicable to Periodic Testing for extension of qualification.
6. 500 and 1000 hours is applicable to Qualification Testing, and to Periodic Testing for renewal of qualification after lapse.
7. 1000 hours is applicable to Periodic Testing for extension of qualification. 2000 hours is applicable to Qualification Testing, and to Periodic Testing for renewal of qualification after lapse.
8. Thrust: 1N
9. No reversals in direction.
10. Torque: 0.8N.cm

2.7 **BURN-IN CONDITIONS**

Characteristics	Symbols	Conditions	Units
Ambient Temperature	T _{amb}	+125 (+0 -3)	°C
Applied Voltage	V _A	750	V

2.8 **OPERATING LIFE CONDITIONS**

The conditions shall be as specified in Para. 2.7.

APPENDIX 'A'
AGREED DEVIATIONS FOR EXXELIA TEMEX (F)

Item Affected	Description of Deviations
<p>Para. 2.1.1, Deviations from the Generic Specification</p>	<p>The following <i>Deviations from Screening Tests – Chart F3</i> shall apply:</p> <ul style="list-style-type: none"> Quality Factor per Electrical and Mechanical Measurements in ESCC Generic Specification No. 3010 and Para. 2.5.1 herein: <p>Quality Factor measurements shall be performed at frequencies comprised between 100 and 400 MHz. The value of the Quality Factor shall be determined at 100MHz by using the following formula:</p> $Q_{fo} = Q_m \times (f_m/f_o)^{3/2}$ <p>Where Q_m is the Quality Factor read at frequency f_m (f_m is that frequency where the quarter-wave line, including the capacitance being measured, is resonating) and $f_o = 100\text{MHz}$.</p> <p>The record sheet shall indicate the Quality Factor at 100MHz, as specified in Para. 2.5.1, as well as the frequency f_m at which the Quality Factor was read.</p>
<p>Para. 2.1.1.1, Deviations from Qualification and Periodic Tests – Chart F4</p>	<ul style="list-style-type: none"> Quality Factor per Electrical and Mechanical Measurements in ESCC Generic Specification No. 3010 and Para. 2.5.1 herein: <p>Quality Factor measurements shall be performed at frequencies comprised between 100 and 400 MHz. The value of the Quality Factor shall be determined at 100MHz by using the following formula:</p> $Q_{fo} = Q_m \times (f_m/f_o)^{3/2}$ <p>Where Q_m is the Quality Factor read at frequency f_m (f_m is that frequency where the quarter-wave line, including the capacitance being measured, is resonating) and $f_o = 100\text{MHz}$.</p> <p>The record sheet shall indicate the Quality Factor at 100MHz, as specified in Para. 2.5.1, as well as the frequency f_m at which the Quality Factor was read.</p> <ul style="list-style-type: none"> Electrical Subgroup (Subgroup 3), Electrical and Mechanical Measurements: Quality Factor measurements shall be performed prior to Solderability.