



**CONNECTORS, ELECTRICAL, RECTANGULAR,
MICROMINIATURE**

BASED ON TYPE MDSA D-CLICK

ESCC Detail Specification No. 3401/091

Issue 1	November 2018
---------	---------------



LEGAL DISCLAIMER AND COPYRIGHT

European Space Agency, Copyright © 2018. All rights reserved.

The European Space Agency disclaims any liability or responsibility, to any person or entity, with respect to any loss or damage caused, or alleged to be caused, directly or indirectly by the use and application of this ESCC publication.

This publication, without the prior permission of the European Space Agency and provided that it is not used for a commercial purpose, may be:

- copied in whole, in any medium, without alteration or modification.
- copied in part, in any medium, provided that the ESCC document identification, comprising the ESCC symbol, document number and document issue, is removed.

DOCUMENTATION CHANGE NOTICE

(Refer to <https://escies.org> for ESCC DCR content)

DCR No.	CHANGE DESCRIPTION

TABLE OF CONTENTS

1	GENERAL	6
1.1	SCOPE	6
1.2	COMPONENT TYPE VARIANTS AND RANGE OF COMPONENTS	6
1.3	MAXIMUM RATINGS	6
1.4	PARAMETER DERATING INFORMATION	6
1.5	PHYSICAL DIMENSIONS	6
1.6	CONTACT ARRANGEMENTS	6
2	APPLICABLE DOCUMENTS	37
3	TERMS, DEFINITIONS, ABBREVIATIONS, SYMBOLS AND UNITS	37
4	REQUIREMENTS	37
4.1	GENERAL	37
4.2	DEVIATIONS FROM GENERIC SPECIFICATION	38
4.2.1	Deviations from Special In-Process Controls	38
4.2.2	Deviations from Final Production Tests (Chart II)	38
4.2.3	Deviations from Burn-in and Electrical Measurements (Chart III)	38
4.2.4	Deviations from Qualification Tests (Chart IV)	38
4.2.5	Deviations from Lot Acceptance Tests (Chart V)	38
4.3	MECHANICAL REQUIREMENTS	38
4.3.1	Dimension Check	38
4.3.2	Weight	38
4.3.3	Contact Capability	39
4.3.4	Contact Retention (in Insert)	39
4.3.5	Mating and Unmating Forces	39
4.3.6	Insert Retention (in Shell)	39
4.3.7	Jackscrew Retention	39
4.3.8	Contact Insertion and Withdrawal Forces	39
4.3.9	Engagement and Separation Forces (Male Contacts)	39
4.3.10	Oversize Pin Exclusion	39
4.3.11	Probe Damage	39
4.3.12	Solderability	39
4.4	MATERIALS AND FINISHES	40
4.4.1	Shell	40
4.4.2	Insert	40
4.4.3	Contacts	40
4.4.3.1	Female Contact	40
4.4.3.2	Male Contact	40
4.4.4	Interfacial Seal	40

4.4.5	Insulated Wire	40
4.4.6	Uninsulated Solid Wire	40
4.4.7	Rear Potting	40
4.4.8	Latch Springs	40
4.4.9	Latch Posts	40
4.4.10	Securing Pieces	41
4.5	MARKING	41
4.5.1	General	41
4.5.2	The ESCC Component Number	41
4.5.3	Characteristics	41
4.5.3.1	Characteristics Applicable to Variants 01 to 06	41
4.5.3.2	Characteristics Applicable to Variants 07 to 09	44
4.5.4	Traceability Information	46
4.6	ELECTRICAL MEASUREMENTS	46
4.6.1	Electrical Measurements at Room Temperature	46
4.6.2	Electrical Measurements at High and Low Temperatures	46
4.6.3	Circuits for Electrical Measurements	46
4.7	BURN-IN AND ELECTRICAL MEASUREMENTS (TABLES 4 AND 5)	46
4.8	ENVIRONMENTAL AND ENDURANCE TESTS (CHARTS IV AND V OF ESCC GENERIC SPECIFICATION NO. 3401)	49
4.8.1	Measurements and Inspections on Completion of Environmental Tests	49
4.8.2	Measurements and Inspections at Intermediate Points during Endurance Tests	49
4.8.3	Measurements and Inspections on Completion of Endurance Tests	49
4.8.4	Conditions for Operating Life Test (Part of Endurance Testing)	49
4.8.5	Electrical Circuit for Operating Life Test	49
4.8.6	Conditions for High Temperature Storage Test (Part of Endurance Testing)	49

1 GENERAL

1.1 SCOPE

This specification details the ratings, physical and electrical characteristics, test and inspection data for Electrical, Rectangular, Microminiature Connectors with Non-Removable Crimp-type Contacts and their associated insulated wires and uninsulated solid wires, based on type MDSA D-Click.

It shall be read in conjunction with:

- ESCC Generic Specification No. [3401](#), Connectors, Electrical, Rectangular and Circular.
- ESCC Detail Specification No. [3401/029](#), Connectors, Electrical, Rectangular, Microminiature, based on type MDM.

the requirements of which are supplemented herein.

1.2 COMPONENT TYPE VARIANTS AND RANGE OF COMPONENTS

Variants of the basic type connectors specified herein and their different sizes, which are also covered by this specification, together with their mechanical characteristics, are scheduled in Table 1(a).

1.3 MAXIMUM RATINGS

The maximum ratings, which shall not be exceeded at any time during use or storage, applicable to the connectors specified herein, are given in Table 1(b).

1.4 PARAMETER DERATING INFORMATION

The derating information applicable to the connectors specified herein is shown in Figure 1.

1.5 PHYSICAL DIMENSIONS

The physical characteristics of the connectors, insulated wires and uninsulated solid wires specified herein are shown in Figure 2.

1.6 CONTACT ARRANGEMENTS

Contact arrangements are shown in Figure 3.

TABLE 1(a) – COMPONENT TYPE VARIANTS AND RANGE OF COMPONENTS

Shell Size	Connector Variants						Mating Force N Max	Unmating Force	
	01	02	03	04	05	06			
	Pigtail with Latch Springs (Note 1)	Pigtail with Latch Posts (Note 1)	90° PCB (2.54mm) Mounting (Note 2)	Straight PCB (2.54mm) Mounting (Note 2)	Straight PCB (1.91mm) Mounting (Note 2)	90° PCB (1.91mm) Mounting (Note 2)		Weight Max. (g)	
							N Max	N Min	
9	4.51	3.3	4.62	5.28	4.95	4.62	25	25	1.3
15	5.06	3.85	5.50	5.94	5.83	5.50	42	42	2
21	5.61	4.4	6.38	7.15	6.60	6.16	58	58	2.9
25	6.05	4.73	6.82	7.59	7.04	6.71	70	70	3.5
31	6.6	5.17	8.47	8.80	7.92	7.59	86	86	4.3
37	7.3	5.83	9.57	10.12	8.80	8.58	103	103	5.1

Shell Size	Jumper Variants			Mating Force N Max	Unmating Force	
	07	08	09			
	1× Variant 01; 1× Variant 02 (Note 1)	2× Variant 01 (Note 1)	2× Variant 02 (Note 1)		Weight Max. (g)	
				N Max	N Min	
9	7.81	9.02	6.6	25	25	1.3
15	8.91	10.12	7.7	42	42	2
21	10.01	11.22	8.8	58	58	2.9
25	10.78	12.1	9.46	70	70	3.5
31	11.77	13.2	10.34	86	86	4.3
37	13.13	14.6	11.66	103	103	5.1

NOTES:

1. The specified maximum weight only applies to the connector with contacts and the associated hardware. It does not apply to cables. See Figure 2.7 for the weight of cable.
2. The specified maximum weight applies to the connector with contacts and the associated hardware.

TABLE 1(b) - MAXIMUM RATINGS

No.	Characteristic	Symbol	Maximum Rating	Unit	Remarks
1	Working Voltage Sea Level	U_R	150	Vrms	Note 1
2	Rated Current: (AWG26 and uninsulated solid wire)	I_R	2.5	A	-
3	Rated Current: (AWG28)	I_R	1.5	A	-
4	Operating Temperature Range	T_{op}	-55 to +125	°C	-
5	Storage Temperature Range	T_{stg}	-55 to +125	°C	-

NOTES:

- Between contacts, and contact and shell.

FIGURE 1 - PARAMETER DERATING INFORMATION

FIGURE 1(a) - WORKING VOLTAGE VERSUS ALTITUDE

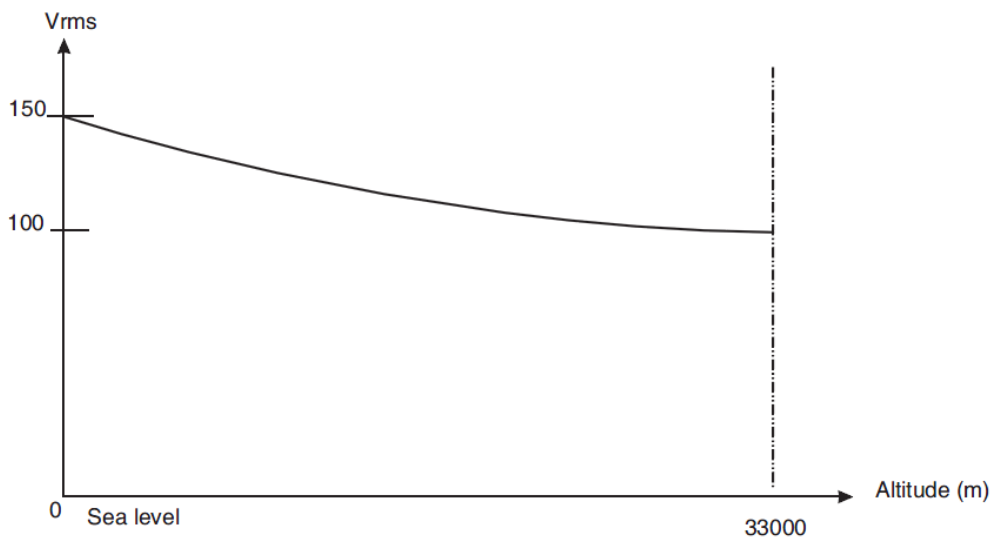
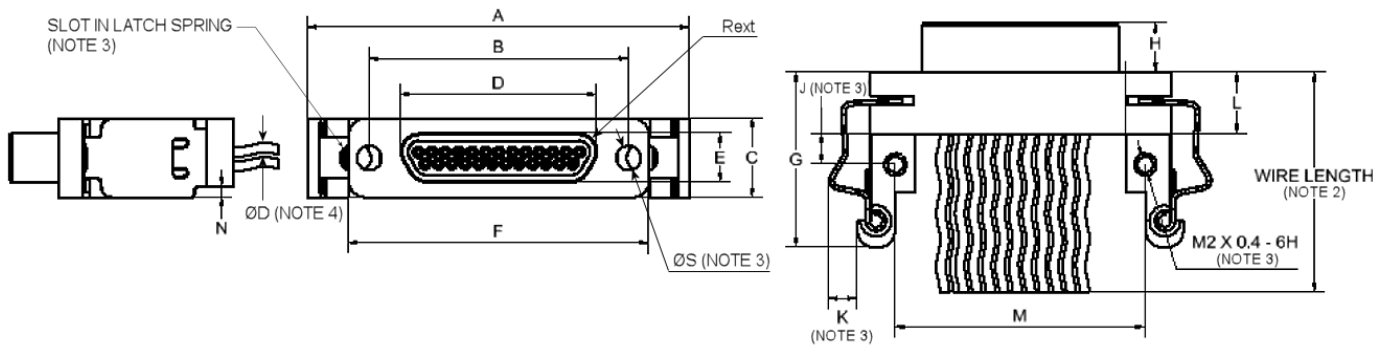

FIGURE 1(b) - MAXIMUM CURRENT VERSUS NUMBER OF CONTACTS

NUMBER OF CURRENT-CARRYING CONTACTS PER CONNECTOR	MAXIMUM CURRENT PER CONTACT (A)	
	WIRE SIZE	
	AWG26 AND UNINSULATED SOLID WIRE	AWG 28
2 - 4	2	1.4
5 - 14	1.8	1.2
15 and over	1.4	0.9

FIGURE 2 - PHYSICAL DIMENSIONS

FIGURE 2.1A – VARIANT 01 – PLUG, MALE CONTACTS, PIGTAIL, LATCH SPRINGS



Shell Size	A Max.	B		C Max.	D Max.	E Max.	F Max.	G Max.	H Max.	J		K Max.
		Min.	Max.							Min.	Max.	
9	26.34	14.22	14.48	7.82	8.48	4.69	18.39	16.73	4.72	2.86	2.96	2.75
15	30.15	18.03	18.29	7.82	12.29	4.69	22.2	16.73	4.72	2.86	2.96	2.75
21	33.96	21.84	22.1	7.82	16.1	4.69	26.01	16.73	4.72	2.86	2.96	2.75
25	36.5	24.38	24.64	7.82	18.64	4.69	28.55	16.73	4.72	2.86	2.96	2.75
31	40.27	28.19	28.45	7.82	22.45	4.69	32.32	16.73	4.72	2.86	2.96	2.75
37	44.12	32	32.26	7.82	26.26	4.69	36.17	16.73	4.72	2.86	2.96	2.75

Shell Size	L		M		N		Rext Max.	ØS	
	Min.	Max.	Min.	Max.	Min.	Max.		Min.	Max.
9	5.66	5.86	13.33	13.53	0.94	1.04	1.699	2.23	2.44
15	5.66	5.86	17.14	17.34	0.94	1.04	1.699	2.23	2.44
21	5.66	5.86	20.95	21.15	0.94	1.04	1.699	2.23	2.44
25	5.66	5.86	23.49	23.69	0.94	1.04	1.699	2.23	2.44
31	5.66	5.86	27.26	27.46	0.94	1.04	1.699	2.23	2.44
37	5.66	5.86	31.11	31.31	0.94	1.04	1.699	2.23	2.44

NOTES:

1. All dimensions are in millimetres.
2. The length of wire is specified in Para. 4.5.3.1.3 of this specification.
3. 2 places.
4. For ØD, refer to Figure 2.7 (Wire Characteristics, Maximum Diameter (mm)) of this specification.

FIGURE 2.1B – VARIANT 01 – RECEPTACLE, FEMALE CONTACTS, PIGTAIL, LATCH SPRINGS

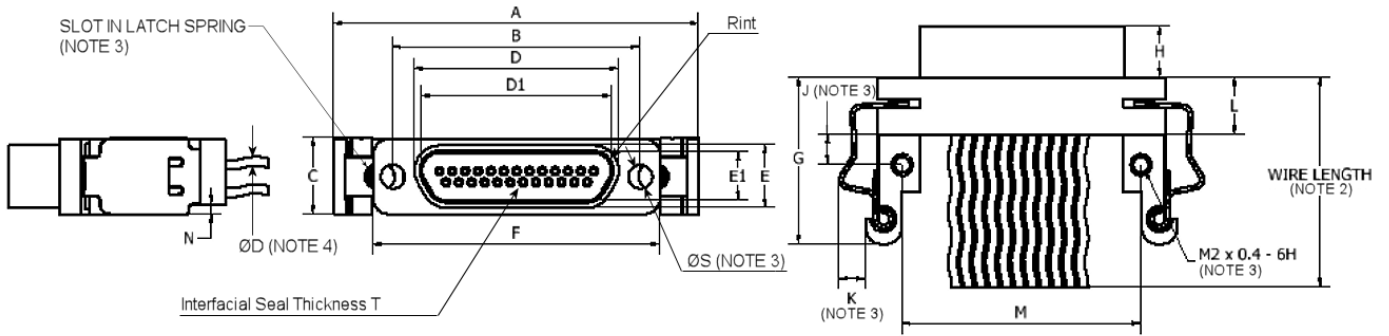

Shell Size	A Max.	B		C Max.	D Max.	D1 Min.	E Max.	E1 Min.	F Max.	G Max.	H Max.	J	
		Min.	Max.									Min.	Max.
9	26.34	14.22	14.48	7.82	10.16	8.49	6.38	4.7	18.39	16.73	5.05	2.86	2.96
15	30.15	18.03	18.29	7.82	13.97	12.3	6.38	4.7	22.2	16.73	5.05	2.86	2.96
21	33.96	21.84	22.1	7.82	17.78	16.11	6.38	4.7	26.01	16.73	5.05	2.86	2.96
25	36.5	24.38	24.64	7.82	20.32	18.65	6.38	4.7	28.55	16.73	5.05	2.86	2.96
31	40.27	28.19	28.45	7.82	24.13	22.46	6.38	4.7	32.32	16.73	5.05	2.86	2.96
37	44.12	32	32.26	7.82	27.94	26.27	6.38	4.7	36.17	16.73	5.05	2.86	2.96

Shell Size	K Max.	L		M		N		Rint Min.	ØS		T	
		Min.	Max.	Min.	Max.	Min.	Max.		Min.	Max.	Min.	Max.
9	2.75	5.66	5.86	13.33	13.53	0.94	1.04	1.704	2.23	2.44	0.6	0.7
15	2.75	5.66	5.86	17.14	17.34	0.94	1.04	1.704	2.23	2.44	0.6	0.7
21	2.75	5.66	5.86	20.95	21.15	0.94	1.04	1.704	2.23	2.44	0.6	0.7
25	2.75	5.66	5.86	23.49	23.69	0.94	1.04	1.704	2.23	2.44	0.6	0.7
31	2.75	5.66	5.86	27.26	27.46	0.94	1.04	1.704	2.23	2.44	0.6	0.7
37	2.75	5.66	5.86	31.11	31.31	0.94	1.04	1.704	2.23	2.44	0.6	0.7

NOTES:

1. All dimensions are in millimetres.
2. The length of wire is specified in Para. 4.5.3.1.3 of this specification.
3. 2 places.
4. For ØD, refer to Figure 2.7 (Wire Characteristics, Maximum Diameter (mm)) of this specification.

FIGURE 2.1C – VARIANT 02 – PLUG, MALE CONTACTS, PIGTAIL, LATCH POSTS
(CONNECTOR SHOWN WITH STANDARD LATCH POSTS)

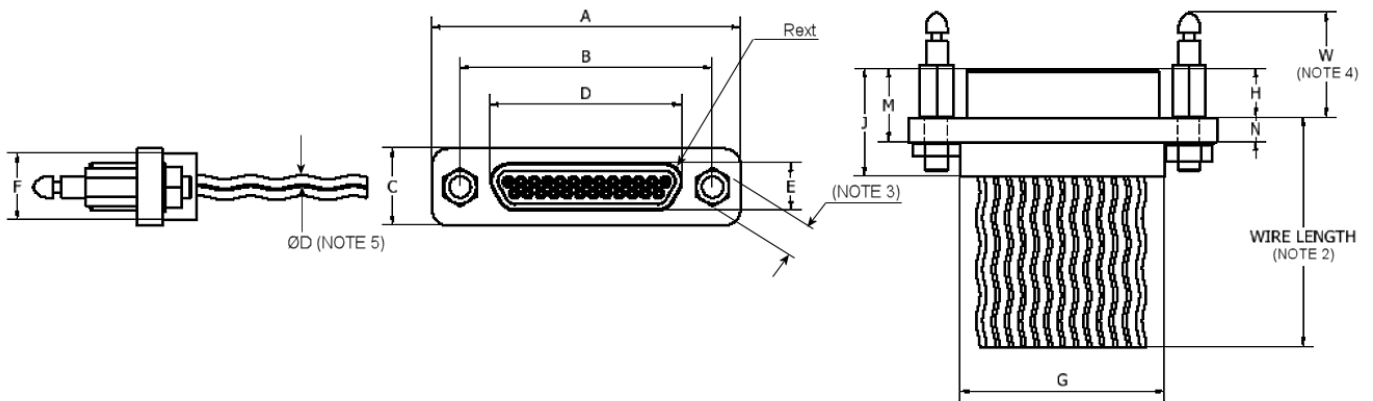

Shell Size	A Max.	B		C Max.	D Max.	E Max.	F Max.	G Max.	H Max.	J Max.	M Max.	N	
		Min.	Max.									Min.	Max.
9	19.94	14.22	14.48	7.82	8.48	4.69	6.86	10.16	4.72	10.57	7.21	2.23	2.49
15	23.75	18.03	18.29	7.82	12.29	4.69	6.86	13.97	4.72	10.57	7.21	2.23	2.49
21	27.56	21.84	22.1	7.82	16.1	4.69	6.86	17.78	4.72	10.57	7.21	2.23	2.49
25	30.1	24.38	24.64	7.82	18.64	4.69	6.86	20.32	4.72	10.57	7.21	2.23	2.49
31	33.91	28.19	28.45	7.82	22.45	4.69	6.86	24.13	4.72	10.57	7.21	2.23	2.49
37	37.72	32	32.26	7.82	26.26	4.69	6.86	27.94	4.72	10.57	7.21	2.23	2.49

Shell Size	Rext Max.	W Max.
9	1.699	10.33
15	1.699	10.33
21	1.699	10.33
25	1.699	10.33
31	1.699	10.33
37	1.699	10.33

NOTES:

1. All dimensions are in millimetres. See Figure 2.4.2 for dimensions of panel-mount latch post.
2. The length of wire is specified in Para. 4.5.3.1.3 of this specification.
3. Hex. 3.2mm (both latch posts).
4. Both latch posts.
5. For ØD, refer to Figure 2.7 (Wire Characteristics, Maximum Diameter (mm)) of this specification.
6. Latch post mounting torque: 0.34 Nm min / 0.44 Nm max.

**FIGURE 2.1D – VARIANT 02 – RECEPTACLE, FEMALE CONTACTS, PIGTAIL, LATCH POSTS
(CONNECTOR SHOWN WITH STANDARD LATCH POSTS)**

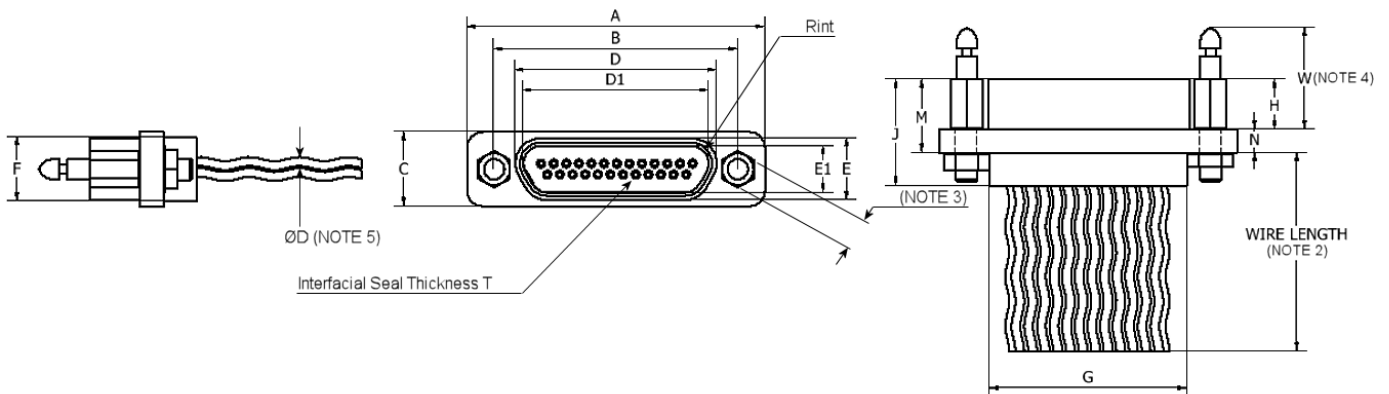

Shell Size	A Max.	B		C Max.	D Max.	D1 Min.	E Max.	E1 Min.	F Max.	G Max.	H Max.	J Max.	M Max.
		Min.	Max.										
9	19.94	14.22	14.48	7.82	10.16	8.49	6.38	4.7	6.86	10.16	5.05	10.9	7.54
15	23.75	18.03	18.29	7.82	13.97	12.3	6.38	4.7	6.86	13.97	5.05	10.9	7.54
21	27.56	21.84	22.1	7.82	17.78	16.11	6.38	4.7	6.86	17.78	5.05	10.9	7.54
25	30.1	24.38	24.64	7.82	20.32	18.65	6.38	4.7	6.86	20.32	5.05	10.9	7.54
31	33.91	28.19	28.45	7.82	24.13	22.46	6.38	4.7	6.86	24.13	5.05	10.9	7.54
37	37.72	32	32.26	7.82	27.94	26.27	6.38	4.7	6.86	27.94	5.05	10.9	7.54

Shell Size	N		Rint Min.	T		W Max.
	Min.	Max.		Min.	Max.	
9	2.23	2.49	1.704	0.6	0.7	10.33
15	2.23	2.49	1.704	0.6	0.7	10.33
21	2.23	2.49	1.704	0.6	0.7	10.33
25	2.23	2.49	1.704	0.6	0.7	10.33
31	2.23	2.49	1.704	0.6	0.7	10.33
37	2.23	2.49	1.704	0.6	0.7	10.33

NOTES:

1. All dimensions are in millimetres. See Figure 2.4.2 for dimensions of panel-mount latch post.
2. The length of wire is specified in Para. 4.5.3.1.3 of this specification.
3. Hex. 3.2mm (both latch posts).
4. Both latch posts.
5. For ØD, refer to Figure 2.7 (Wire Characteristics, Maximum Diameter (mm)) of this specification.
6. Latch post mounting torque: 0.34 Nm min / 0.44 Nm max.

**FIGURE 2.1E – VARIANT 03 – PLUG, MALE CONTACTS, 90° PCB (2.54mm) MOUNTING
(CONNECTOR SHOWN WITH STANDARD LATCH POSTS)**

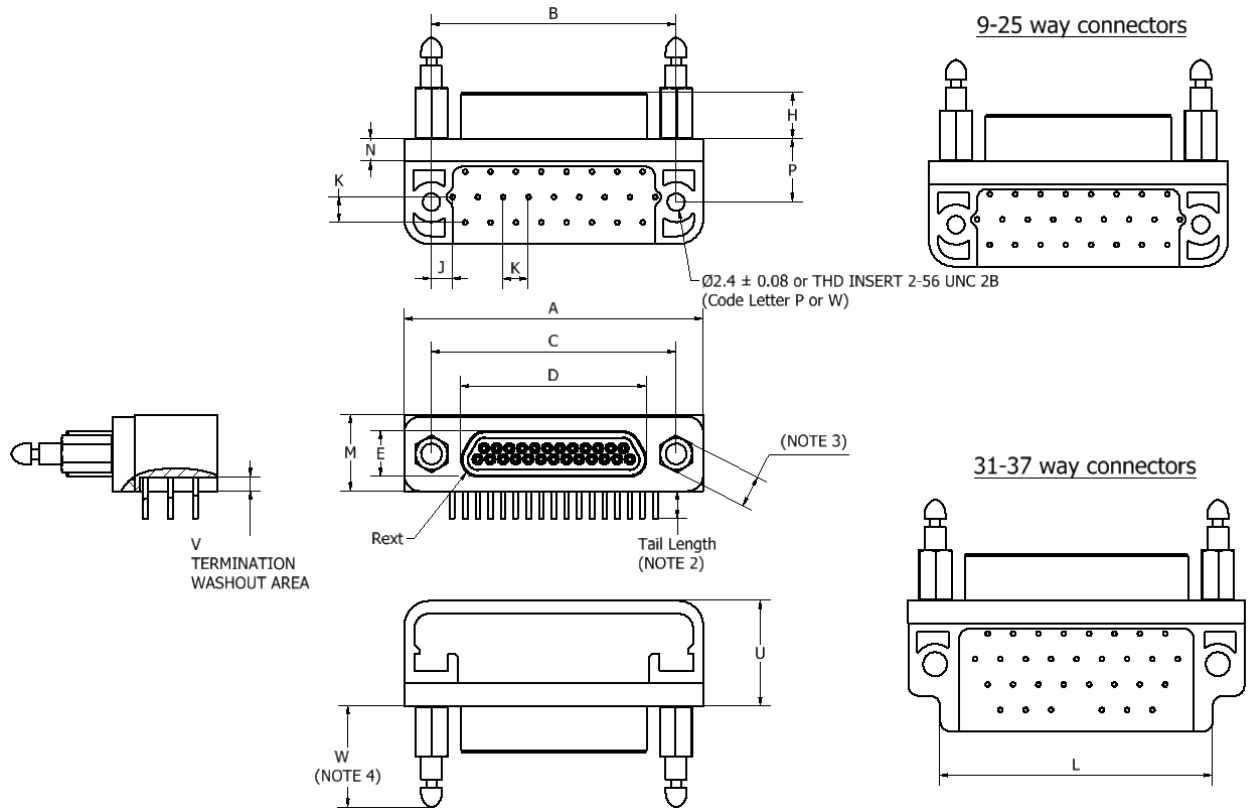

Shell Size	A Max.	B		C		D Max.	E Max.	H Max.	J Typ.	K Typ.	L Max.
		Min.	Max.	Min.	Max.						
9	19.94	14.22	14.48	14.22	14.48	8.48	4.69	4.72	2.11	2.54	-
15	23.75	18.03	18.29	18.03	18.29	12.29	4.69	4.72	2.74	2.54	-
21	27.56	21.84	22.1	21.84	22.1	16.1	4.69	4.72	2.11	2.54	-
25	30.1	24.38	24.64	24.38	24.64	18.64	4.69	4.72	2.54	2.54	-
31	33.91	28.19	28.45	28.19	28.45	22.45	4.69	4.72	4.01	2.54	27.44
37	37.72	32	32.26	32	32.26	26.26	4.69	4.72	4.65	2.54	30.1

Shell Size	M		N		P		Rext Max.	U Max.	V		W Max.
	Min.	Max.	Min.	Max.	Min.	Max.			Min.	Max.	
9	7.49	7.75	2.23	2.49	6.1	6.6	1.699	10.8	0.89	1.55	10.33
15	7.49	7.75	2.23	2.49	6.1	6.6	1.699	10.8	0.89	1.55	10.33
21	7.49	7.75	2.23	2.49	6.1	6.6	1.699	10.8	0.89	1.55	10.33
25	7.49	7.75	2.23	2.49	6.1	6.6	1.699	10.8	0.89	1.55	10.33
31	7.49	7.75	2.23	2.49	6.1	6.6	1.699	13.34	0.89	1.55	10.33
37	7.49	7.75	2.23	2.49	6.1	6.6	1.699	13.34	0.89	1.55	10.33

NOTES:

1. All dimensions are in millimetres. See Figure 2.4.2 for dimensions of panel-mount latch post.
2. For tail length, refer to Para. 4.5.3.1.3 of this specification.
3. Hex. 3.2mm (both latch posts).
4. Both latch posts.
5. Latch post mounting torque: 0.34 Nm min / 0.44 Nm max.

FIGURE 2.1F – VARIANT 03 – RECEPTACLE, FEMALE CONTACTS, 90° PCB (2.54mm) MOUNTING

(CONNECTOR SHOWN WITH STANDARD LATCH POSTS)

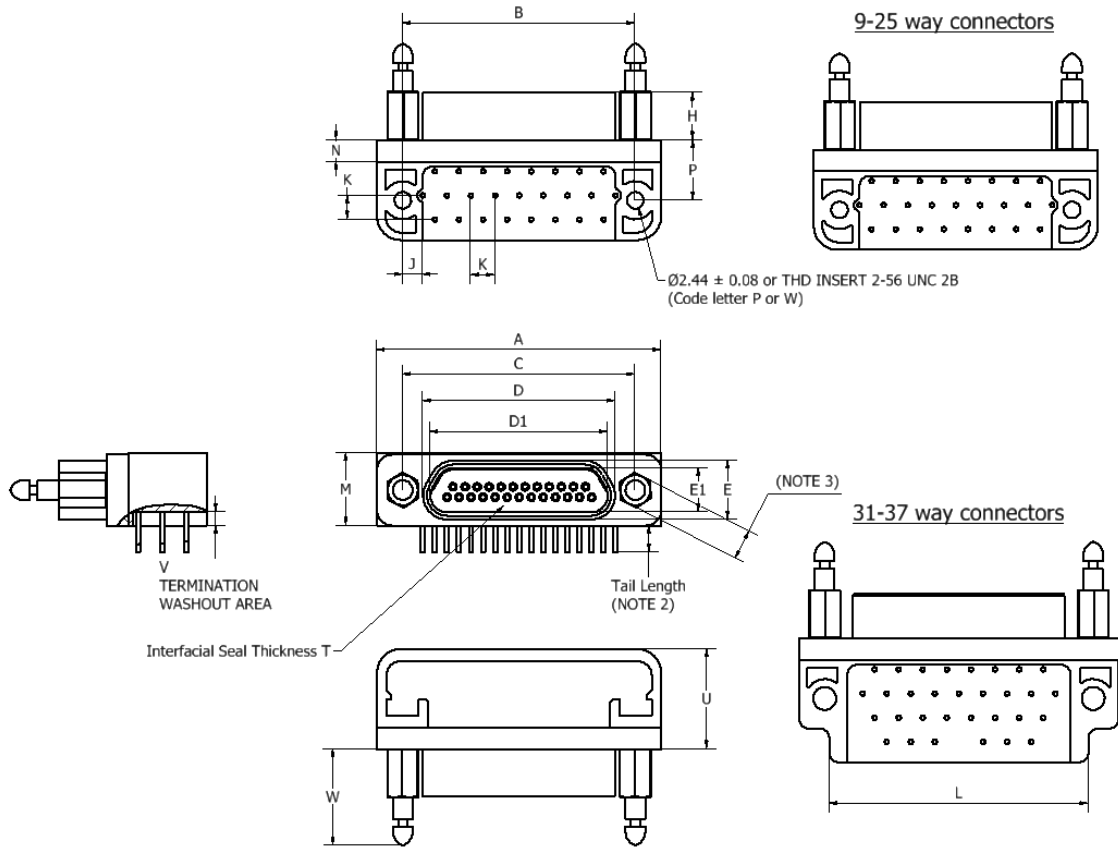

Shell Size	A Max.	B		C		D Max.	D1 Min.	E Max.	E1 Min.	H Max.	J Typ.	K Typ.	L Max.
		Min.	Max.	Min.	Max.								
9	19.94	14.22	14.48	7.61	7.82	10.16	8.49	6.38	4.7	5.05	2.11	2.54	-
15	23.75	18.03	18.29	7.61	7.82	13.97	12.3	6.38	4.7	5.05	2.74	2.54	-
21	27.56	21.84	22.1	7.61	7.82	17.78	16.11	6.38	4.7	5.05	2.11	2.54	-
25	30.1	24.38	24.64	7.61	7.82	20.32	18.65	6.38	4.7	5.05	2.11	2.54	-
31	33.91	28.19	28.45	7.61	7.82	24.13	22.46	6.38	4.7	5.05	4.01	2.54	27.44
37	37.72	32	32.26	7.61	7.82	27.94	26.27	6.38	4.7	5.05	4.65	2.54	30.1

Shell Size	M		N		P		Rint Min.	T		U Max.	V		W Max.
	Min.	Max.	Min.	Max.	Min.	Max.		Min.	Max.		Min.	Max.	
9	7.49	7.75	2.23	2.49	6.1	6.6	1.704	0.6	0.7	10.8	0.89	1.55	10.33
15	7.49	7.75	2.23	2.49	6.1	6.6	1.704	0.6	0.7	10.8	0.89	1.55	10.33
21	7.49	7.75	2.23	2.49	6.1	6.6	1.704	0.6	0.7	10.8	0.89	1.55	10.33
25	7.49	7.75	2.23	2.49	6.1	6.6	1.704	0.6	0.7	10.8	0.89	1.55	10.33
31	7.49	7.75	2.23	2.49	6.1	6.6	1.704	0.6	0.7	13.34	0.89	1.55	10.33
37	7.49	7.75	2.23	2.49	6.1	6.6	1.704	0.6	0.7	13.34	0.89	1.55	10.33

NOTES:

1. All dimensions are in millimetres. See Figure 2.4.2 for dimensions of panel-mount latch post.
2. For tail length, refer to Para. 4.5.3.1.3 of this specification.
3. Hex. 3.2mm (both latch posts).
4. Both latch posts.
5. Latch post mounting torque: 0.34 Nm min / 0.44 Nm max.

FIGURE 2.1G – VARIANT 04 – PLUG, MALE CONTACTS, STRAIGHT PCB (2.54mm) MOUNTING

(CONNECTOR SHOWN WITH STANDARD LATCH POSTS)

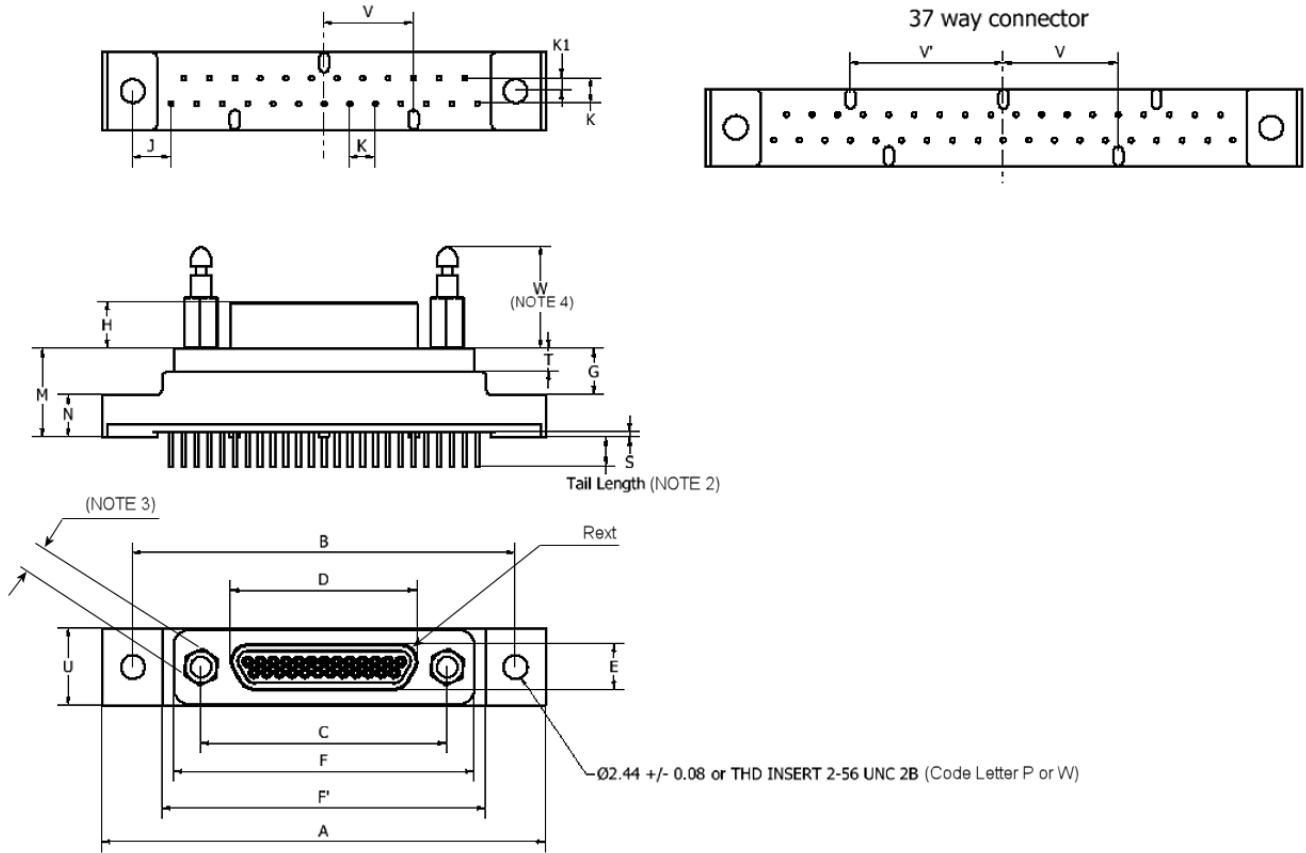

Shell Size	A Max.	B		C		D Max.	E Max.	F Max.	F' Max.	G Min.	H Max.	J Typ.	K Typ.
		Min.	Max.	Min.	Max.								
9	35.31	29.03	29.39	14.22	14.48	8.48	4.69	19.94	19.94	4.6	4.72	9.53	2.54
15	35.31	29.03	29.39	18.03	18.29	12.29	4.69	23.75	24	4.6	4.72	5.72	2.54
21	42.93	36.65	37.01	21.84	22.1	16.1	4.69	27.56	29.72	4.6	4.72	5.72	2.54
25	44.2	37.92	28.28	24.38	24.64	18.64	4.69	30.1	32.39	4.6	4.72	3.81	2.54
31	51.82	45.54	45.9	28.19	28.45	22.45	4.69	33.91	40.01	4.6	4.72	3.81	2.54
37	59.44	53.16	53.52	32	32.26	26.26	4.69	37.72	47.63	4.6	4.72	3.81	2.54

Shell Size	K1 Typ.	M		N		Rext Max.	S		T		U Max.	V Max.
		Min.	Max.	Min.	Max.		Min.	Max.	Min.	Max.		
9	1.27	8.62	9.02	4	4.3	1.699	0	1.1	2.23	2.49	7.82	-
15	1.27	8.62	9.02	4	4.3	1.699	0	1.1	2.23	2.49	7.82	-
21	1.27	8.62	9.02	4	4.3	1.699	0	1.1	2.23	2.49	7.82	6.4
25	1.27	8.62	9.02	4	4.3	1.699	0	1.1	2.23	2.49	7.82	8.94
31	1.27	8.62	9.02	4	4.3	1.699	0	1.1	2.23	2.49	7.82	12.75
37	1.27	8.62	9.02	4	4.3	1.699	0	1.1	2.23	2.49	7.82	11.45

Shell Size	V' Max.	W Max.
9	-	10.33
15	-	10.33
21	-	10.33
25	-	10.33
31	-	10.33
37	16.14	10.33

NOTES:

1. All dimensions are in millimetres. See Figure 2.4.2 for dimensions of panel-mount latch post.
2. For tail length, refer to Para. 4.5.3.1.3 of this specification.
3. Hex. 3.2mm (both latch posts).
4. Both latch posts.
5. Latch post mounting torque: 0.34 Nm min / 0.44 Nm max.

FIGURE 2.1H – VARIANT 04 – RECEPTACLE, FEMALE CONTACTS, STRAIGHT PCB (2.54mm) MOUNTING

(CONNECTOR SHOWN WITH STANDARD LATCH POSTS)

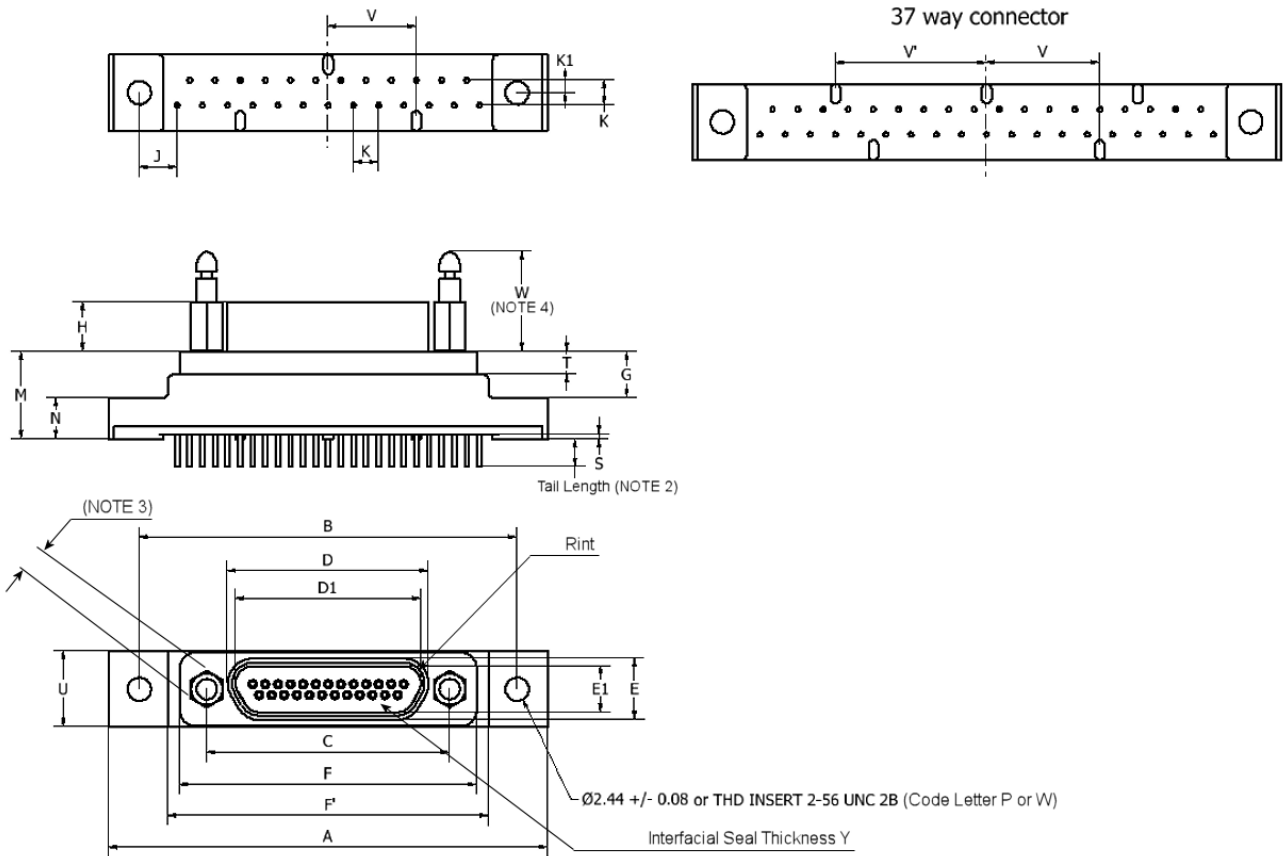

Shell Size	A Max.	B		C		D Max.	D1 Min.	E Max.	E1 Min.	F Max.	F' Max.	G Min.	H Max.
		Min.	Max.	Min.	Max.								
9	35.31	29.03	29.39	14.22	14.48	10.16	8.49	6.38	4.7	19.94	19.94	4.6	5.05
15	35.31	29.03	29.39	18.03	18.29	13.97	12.3	6.38	4.7	23.75	24	4.6	5.05
21	42.93	36.65	37.01	21.84	22.1	17.78	16.11	6.38	4.7	27.56	29.72	4.6	5.05
25	44.2	37.92	28.28	24.38	24.64	20.32	18.65	6.38	4.7	30.1	32.39	4.6	5.05
31	51.82	45.54	45.9	28.19	28.45	24.13	22.46	6.38	4.7	33.91	40.01	4.6	5.05
37	59.44	53.16	53.52	32	32.26	27.94	26.27	6.38	4.7	37.72	47.63	4.6	5.05

Shell Size	J Typ.	K Typ.	K1 Typ.	M		N		Rint Min.	S		T		U Max.
				Min.	Max.	Min.	Max.		Min.	Max.	Min.	Max.	
9	9.53	2.54	1.27	8.62	9.02	4	4.3	1.704	0	1.1	2.23	2.49	7.82
15	5.72	2.54	1.27	8.62	9.02	4	4.3	1.704	0	1.1	2.23	2.49	7.82
21	5.72	2.54	1.27	8.62	9.02	4	4.3	1.704	0	1.1	2.23	2.49	7.82
25	3.81	2.54	1.27	8.62	9.02	4	4.3	1.704	0	1.1	2.23	2.49	7.82
31	3.81	2.54	1.27	8.62	9.02	4	4.3	1.704	0	1.1	2.23	2.49	7.82
37	3.81	2.54	1.27	8.62	9.02	4	4.3	1.704	0	1.1	2.23	2.49	7.82

Shell Size	V Max.	V' Max.	W Max.	Y	
				Min.	Max.
9	-	-	10.33	0.6	0.7
15	-	-	10.33	0.6	0.7
21	6.4	-	10.33	0.6	0.7
25	8.94	-	10.33	0.6	0.7
31	12.75	-	10.33	0.6	0.7
37	11.45	16.14	10.33	0.6	0.7

NOTES:

1. All dimensions are in millimetres. See Figure 2.4.2 for dimensions of panel-mount latch post.
2. For tail length, refer to Para. 4.5.3.1.3 of this specification.
3. Hex. 3.2mm (both latch posts).
4. Both latch posts.
5. Latch post mounting torque: 0.34 Nm min / 0.44 Nm max.

**FIGURE 2.11 – VARIANT 05 – PLUG, MALE CONTACTS, STRAIGHT PCB (1.91mm) MOUNTING
(CONNECTOR SHOWN WITH STANDARD LATCH POSTS)**

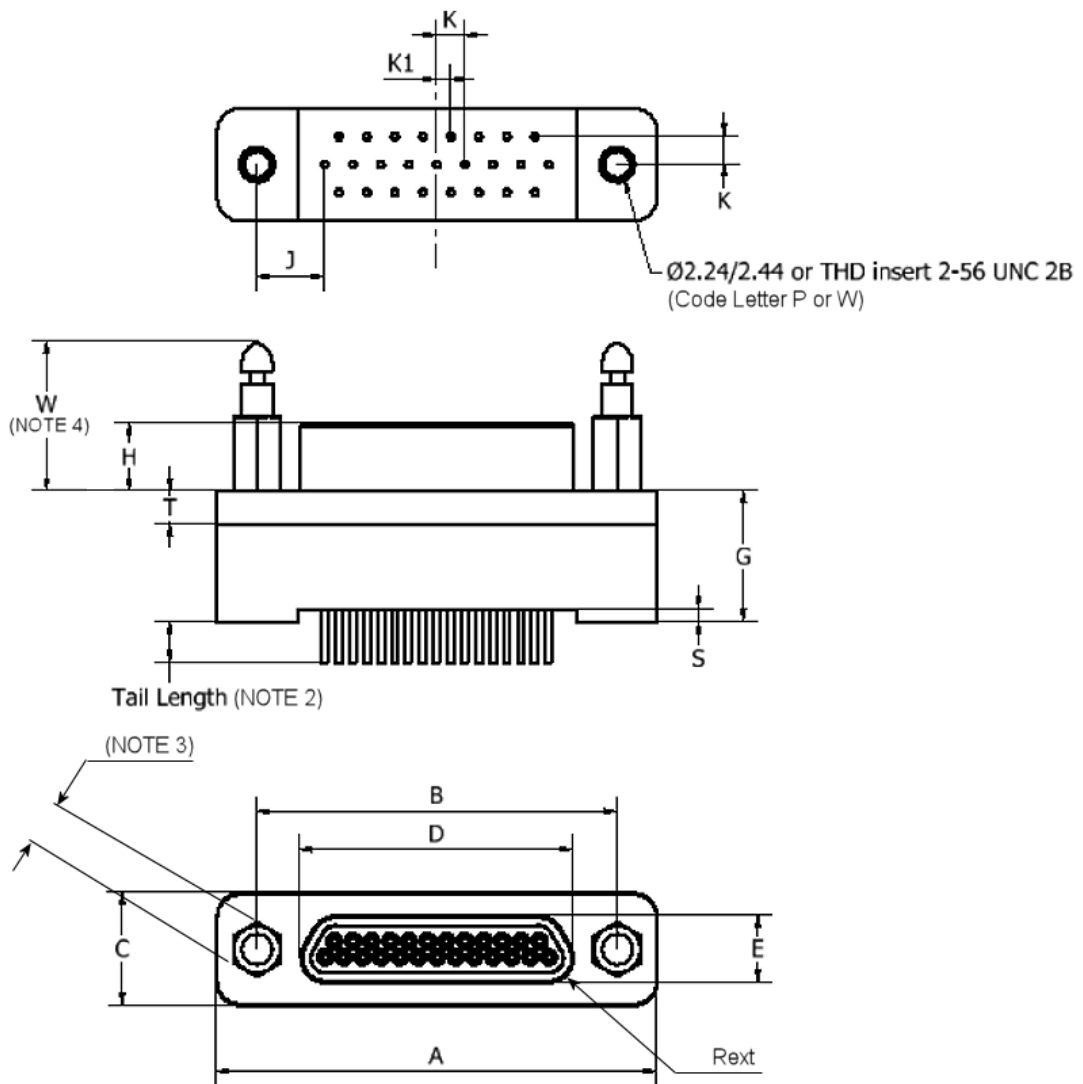

Shell Size	A Max.	B		C		D Max.	E Max.	G		H Max.	J Typ.	K Typ.	K1 Typ.
		Min.	Max.	Min.	Max.			Min.	Max.				
9	19.94	14.22	14.48	7.61	7.87	8.48	4.69	8.73	9.03	4.72	3.38	1.91	0.96
15	23.75	18.03	18.29	7.61	7.87	12.29	4.69	8.73	9.03	4.72	4.32	1.91	0.96
21	27.56	21.84	22.1	7.61	7.87	16.1	4.69	8.73	9.03	4.72	4.32	1.91	0.96
25	30.1	24.38	24.64	7.61	7.87	18.64	4.69	8.73	9.03	4.72	4.65	1.91	0.96
31	33.91	28.19	28.45	7.61	7.87	22.45	4.69	8.73	9.03	4.72	4.65	1.91	0.96
37	37.72	32	32.26	7.61	7.87	26.26	4.69	8.73	9.03	4.72	4.65	1.91	0.96

Shell Size	Rext Max.	S		T		W Max.
		Min.	Max.	Min.	Max.	
9	1.699	0.38	1.02	2.23	2.49	10.33
15	1.699	0.38	1.02	2.23	2.49	10.33
21	1.699	0.38	1.02	2.23	2.49	10.33
25	1.699	0.38	1.02	2.23	2.49	10.33
31	1.699	0.38	1.02	2.23	2.49	10.33
37	1.699	0.38	1.02	2.23	2.49	10.33

NOTES:

1. All dimensions are in millimetres. See Figure 2.4.2 for dimensions of panel-mount latch post.
2. For tail length, refer to Para. 4.5.3.1.3 of this specification.
3. Hex. 3.2mm (both latch posts).
4. Both latch posts.
5. Latch post mounting torque: 0.34 Nm min / 0.44 Nm max.

FIGURE 2.1J – VARIANT 05 – RECEPTACLE, FEMALE CONTACTS, STRAIGHT PCB (1.91mm) MOUNTING

(CONNECTOR SHOWN WITH STANDARD LATCH POSTS)

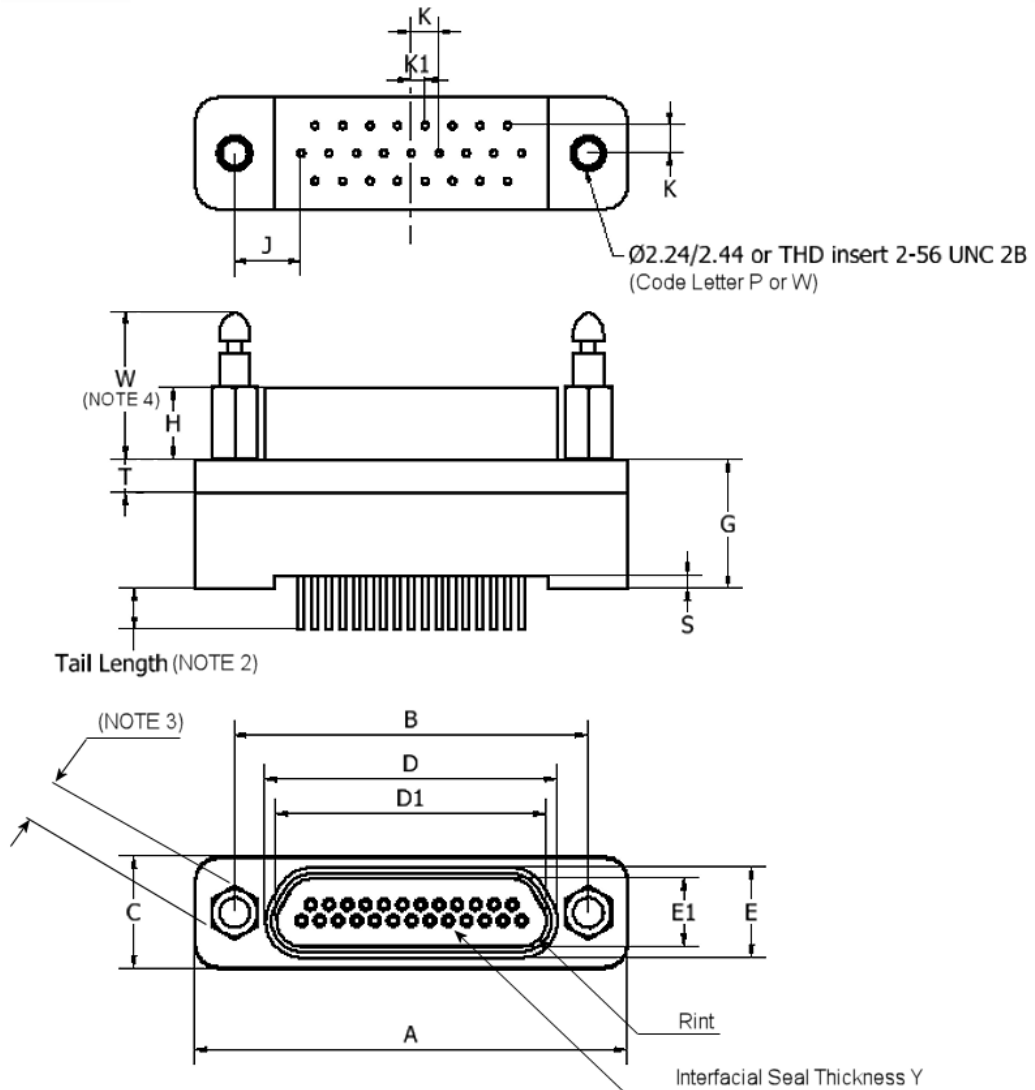

Shell Size	A Max.	B		C		D Max.	D1 Min.	E Max.	E1 Min.	G		H Max.	J Typ.
		Min.	Max.	Min.	Max.					Min.	Max.		
9	19.94	14.22	14.48	7.61	7.82	10.16	8.49	6.38	4.7	8.73	9.03	5.05	3.38
15	23.75	18.03	18.29	7.61	7.82	13.97	12.3	6.38	4.7	8.73	9.03	5.05	4.32
21	27.56	21.84	22.1	7.61	7.82	17.78	16.11	6.38	4.7	8.73	9.03	5.05	4.32
25	30.1	24.38	24.64	7.61	7.82	20.32	18.65	6.38	4.7	8.73	9.03	5.05	4.65
31	33.91	28.19	28.45	7.61	7.82	24.13	22.46	6.38	4.7	8.73	9.03	5.05	4.65
37	37.72	32	32.26	7.61	7.82	27.94	26.27	6.38	4.7	8.73	9.03	5.05	4.65

Shell Size	K Typ.	K1 Typ.	Rint Min.	S		T		W Max.	Y	
				Min.	Max.	Min.	Max.		Min.	Max.
9	1.91	0.96	1.704	0.38	1.02	2.23	2.49	10.33	0.6	0.7
15	1.91	0.96	1.704	0.38	1.02	2.23	2.49	10.33	0.6	0.7
21	1.91	0.96	1.704	0.38	1.02	2.23	2.49	10.33	0.6	0.7
25	1.91	0.96	1.704	0.38	1.02	2.23	2.49	10.33	0.6	0.7
31	1.91	0.96	1.704	0.38	1.02	2.23	2.49	10.33	0.6	0.7
37	1.91	0.96	1.704	0.38	1.02	2.23	2.49	10.33	0.6	0.7

NOTES:

1. All dimensions are in millimetres. See Figure 2.4.2 for dimensions of panel-mount latch post.
2. For tail length, refer to Para. 4.5.3.1.3 of this specification.
3. Hex. 3.2mm (both latch posts).
4. Both latch posts.
5. Latch post mounting torque: 0.34 Nm min / 0.44 Nm max.

**FIGURE 2.1K – VARIANT 06 – PLUG, MALE CONTACTS, 90° PCB (1.91mm) MOUNTING
(CONNECTOR SHOWN WITH STANDARD LATCH POSTS)**

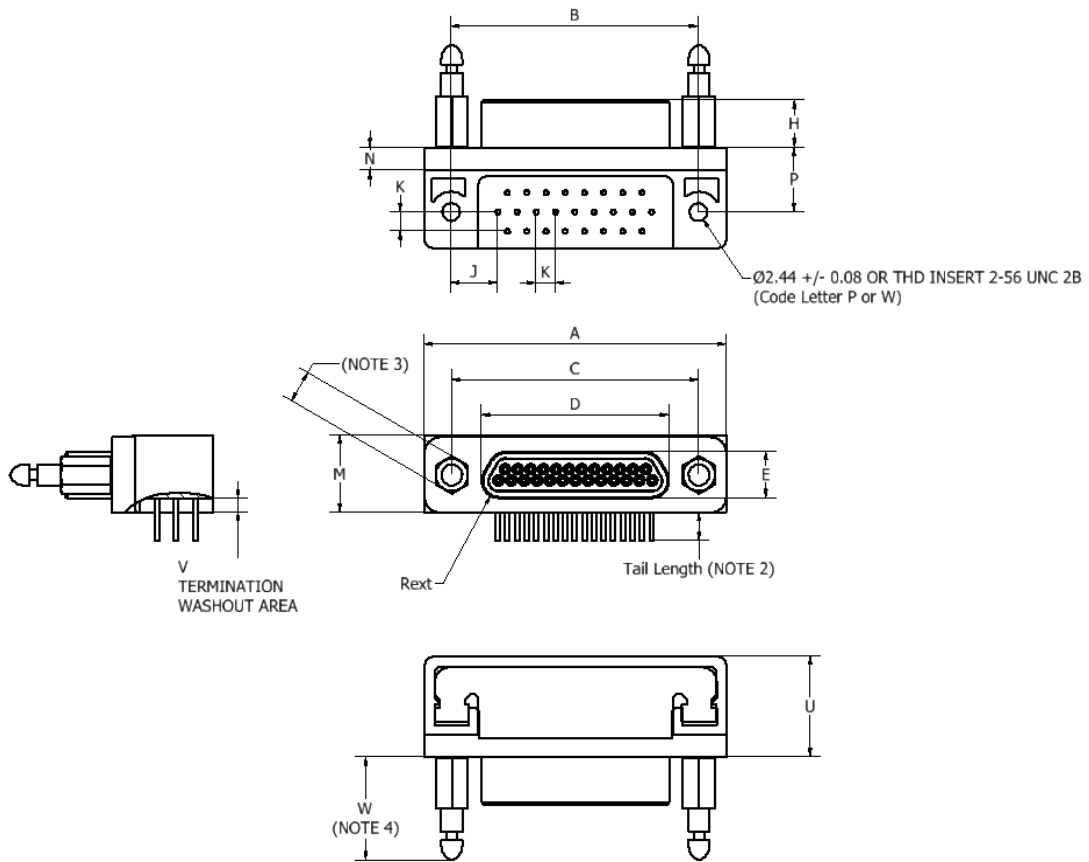

Shell Size	A Max.	B		C		D Max.	E Max.	H Max.	J Typ.	K Typ.	M	
		Min.	Max.	Min.	Max.						Min.	Max.
9	19.94	14.22	14.48	14.22	14.48	8.48	4.69	4.72	3.38	1.91	7.61	7.87
15	23.75	18.03	18.29	18.03	18.29	12.29	4.69	4.72	4.32	1.91	7.61	7.87
21	27.56	21.84	22.1	21.84	22.1	16.1	4.69	4.72	4.32	1.91	7.61	7.87
25	30.1	24.38	24.64	24.38	24.64	18.64	4.69	4.72	4.65	1.91	7.61	7.87
31	33.91	28.19	28.45	28.19	28.45	22.45	4.69	4.72	4.65	1.91	7.61	7.87
37	37.72	32	32.26	32	32.26	26.26	4.69	4.72	4.65	1.91	7.61	7.87

Shell Size	N		P		Rext Max.	U Max.	V		W Max.
	Min.	Max.	Min.	Max.			Min.	Max.	
9	2.23	2.49	6.1	6.6	1.699	10.16	0.89	1.55	10.33
15	2.23	2.49	6.1	6.6	1.699	10.16	0.89	1.55	10.33
21	2.23	2.49	6.1	6.6	1.699	10.16	0.89	1.55	10.33
25	2.23	2.49	6.1	6.6	1.699	10.16	0.89	1.55	10.33
31	2.23	2.49	6.1	6.6	1.699	10.16	0.89	1.55	10.33
37	2.23	2.49	6.1	6.6	1.699	10.16	0.89	1.55	10.33

NOTES:

1. All dimensions are in millimetres. See Figure 2.4.2 for dimensions of panel-mount latch post.
2. For tail length, refer to Para. 4.5.3.1.3 of this specification.
3. Hex. 3.2mm (both latch posts).
4. Both latch posts.
5. Latch post mounting torque: 0.34 Nm min / 0.44 Nm max.

FIGURE 2.1L – VARIANT 06 – RECEPTACLE, FEMALE CONTACTS, 90° PCB (1.91mm) MOUNTING

(CONNECTOR SHOWN WITH STANDARD LATCH POSTS)

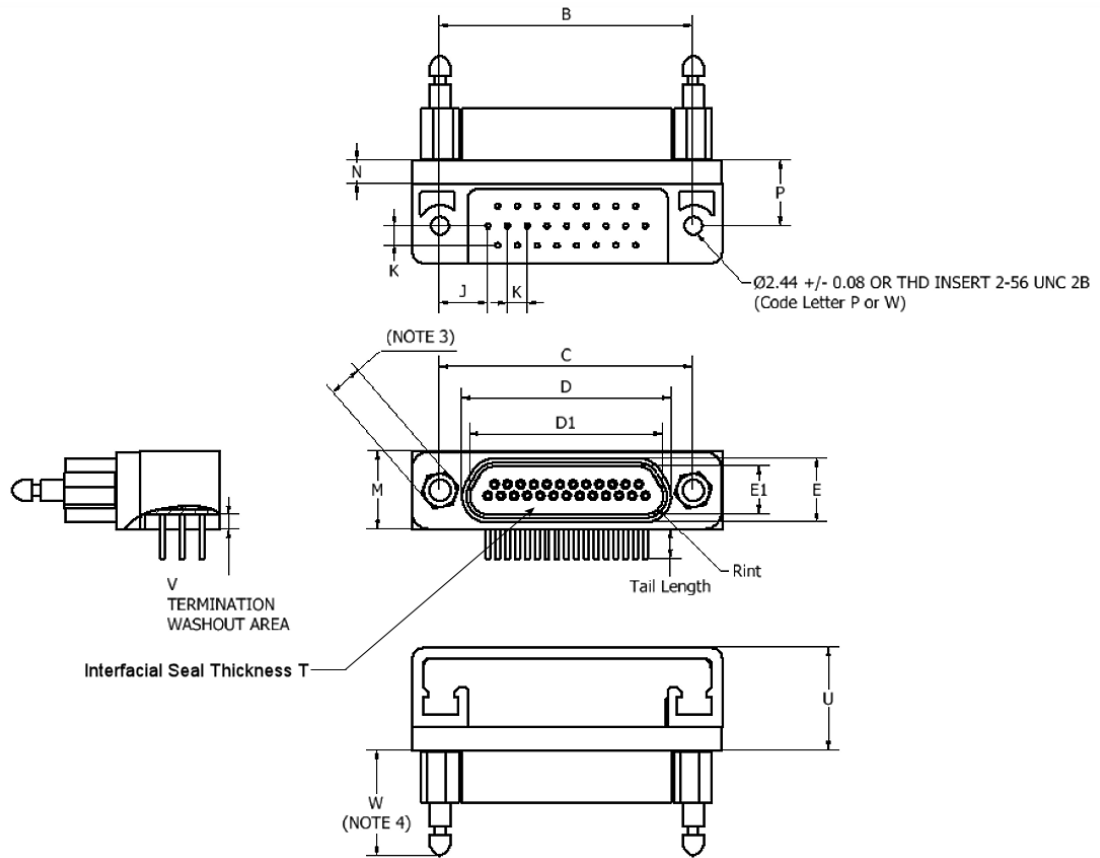

Shell Size	A Max.	B		C		D Max.	D1 Min.	E Max.	E1 Min.	H Max.	J Typ.	K Typ.
		Min.	Max.	Min.	Max.							
9	19.94	14.22	14.48	14.22	14.48	10.16	8.49	6.38	4.7	5.05	3.38	1.91
15	23.75	18.03	18.29	18.03	18.29	13.97	12.3	6.38	4.7	5.05	4.32	1.91
21	27.56	21.84	22.1	21.84	22.1	17.78	16.11	6.38	4.7	5.05	4.32	1.91
25	30.1	24.38	24.64	24.38	24.64	20.32	18.65	6.38	4.7	5.05	4.65	1.91
31	33.91	28.19	28.45	28.19	28.45	24.13	22.46	6.38	4.7	5.05	4.65	1.91
37	37.72	32	32.26	32	32.26	27.94	26.27	6.38	4.7	5.05	4.65	1.91

Shell Size	M		N		P		Rint Min.	T		U Max.	V		W Max.
	Min.	Max.	Min.	Max.	Min.	Max.		Min.	Max.		Min.	Max.	
9	7.61	7.87	2.23	2.49	6.1	6.6	1.704	0.6	0.7	10.16	0.89	1.55	10.33
15	7.61	7.87	2.23	2.49	6.1	6.6	1.704	0.6	0.7	10.16	0.89	1.55	10.33
21	7.61	7.87	2.23	2.49	6.1	6.6	1.704	0.6	0.7	10.16	0.89	1.55	10.33
25	7.61	7.87	2.23	2.49	6.1	6.6	1.704	0.6	0.7	10.16	0.89	1.55	10.33
31	7.61	7.87	2.23	2.49	6.1	6.6	1.704	0.6	0.7	10.16	0.89	1.55	10.33
37	7.61	7.87	2.23	2.49	6.1	6.6	1.704	0.6	0.7	10.16	0.89	1.55	10.33

NOTES:

1. All dimensions are in millimetres. See Figure 2.4.2 for dimensions of panel-mount latch post.
2. For tail length, refer to Para. 4.5.3.1.3 of this specification.
3. Hex. 3.2mm (both latch posts).
4. Both latch posts.
5. Latch post mounting torque: 0.34 Nm min / 0.44 Nm max.

FIGURE 2.1M – VARIANT 07 – JUMPER, CONNECTOR 1: VARIANT 01,
CONNECTOR 2: VARIANT 02

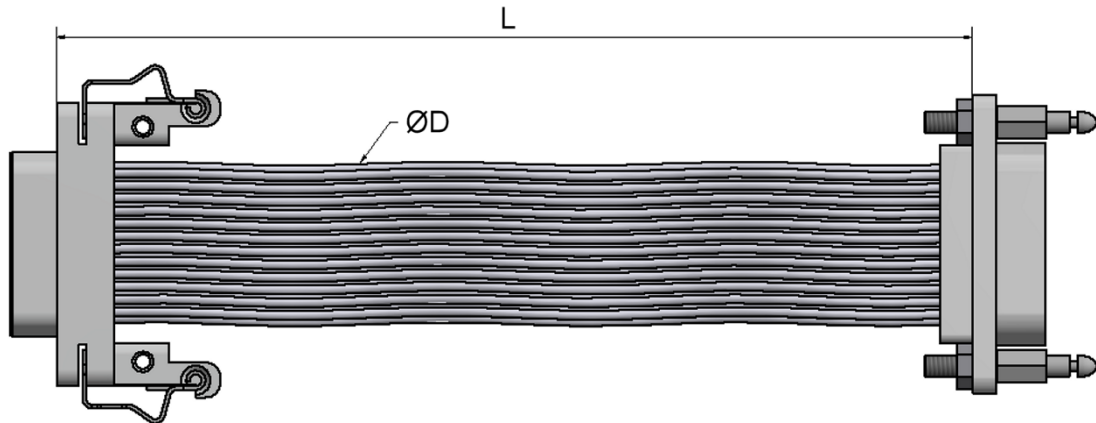

NOTES:

1. The length of wire is specified in Para. 4.5.3.2.5 of this specification.
2. For ØD, refer to Figure 2.7 (Wire Characteristics, Maximum Diameter (mm)) of this specification.

FIGURE 2.1N – VARIANT 08 – JUMPER, CONNECTORS 1 AND 2: VARIANT 01

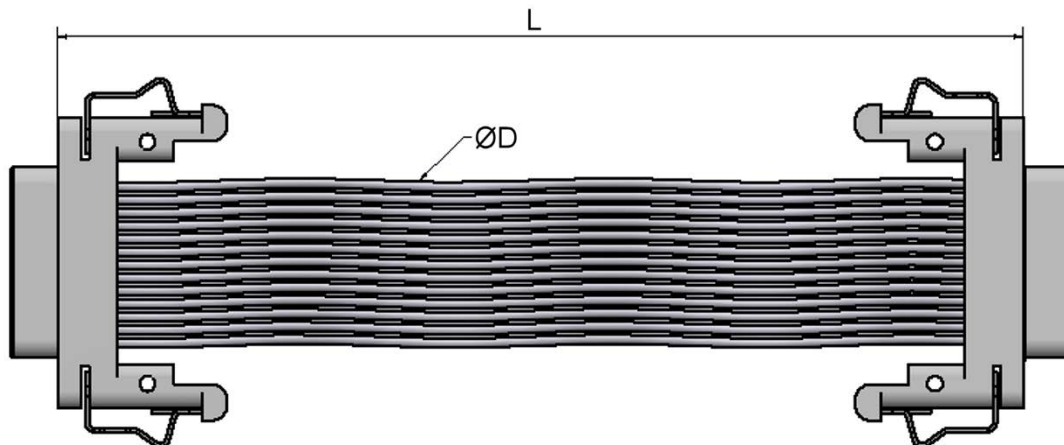

NOTES:

1. The length of wire is specified in Para. 4.5.3.2.5 of this specification.
2. For ØD, refer to Figure 2.7 (Wire Characteristics, Maximum Diameter (mm)) of this specification.

FIGURE 2.10 – VARIANT 09 – JUMPER, CONNECTORS 01 AND 02: VARIANT 02

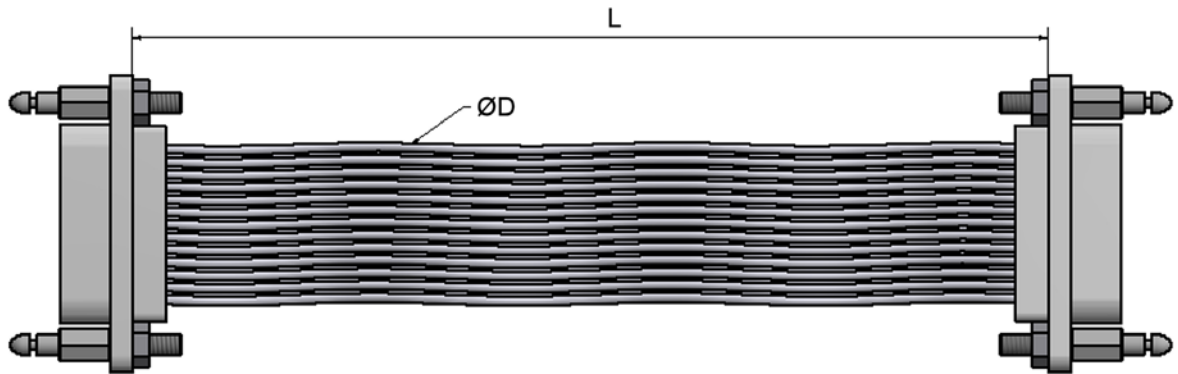

NOTES:

1. The length of wire is specified in Para. 4.5.3.2.5 of this specification.
2. For ØD, refer to Figure 2.7 (Wire Characteristics, Maximum Diameter (mm)) of this specification.

FIGURE 2.2 – SECURING PIECE FOR VARIANTS WITH LATCH SPRINGS
(FOR VARIANTS 01, 07 AND 08)

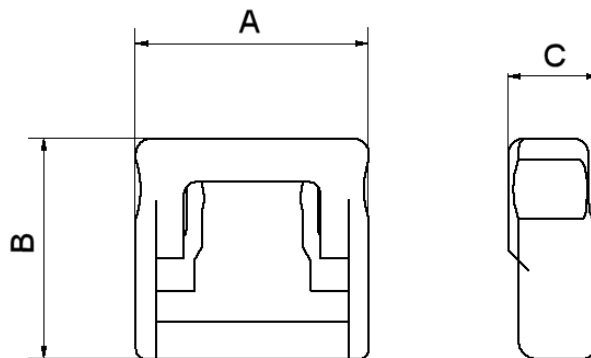

Symbol	Dimensions mm	
	Min.	Max.
A	9.1	9.35
B	8.6	8.85
C	3.5	3.8

NOTES:

1. Securing pieces (2 securing pieces are supplied with each connector) are optional. See Paras. 4.5.3.1.4 and 4.5.3.2.6 for details.

2. Securing pieces are designed to prevent accidental demating and they can only be fitted and locked if connectors are mated properly, as shown below.

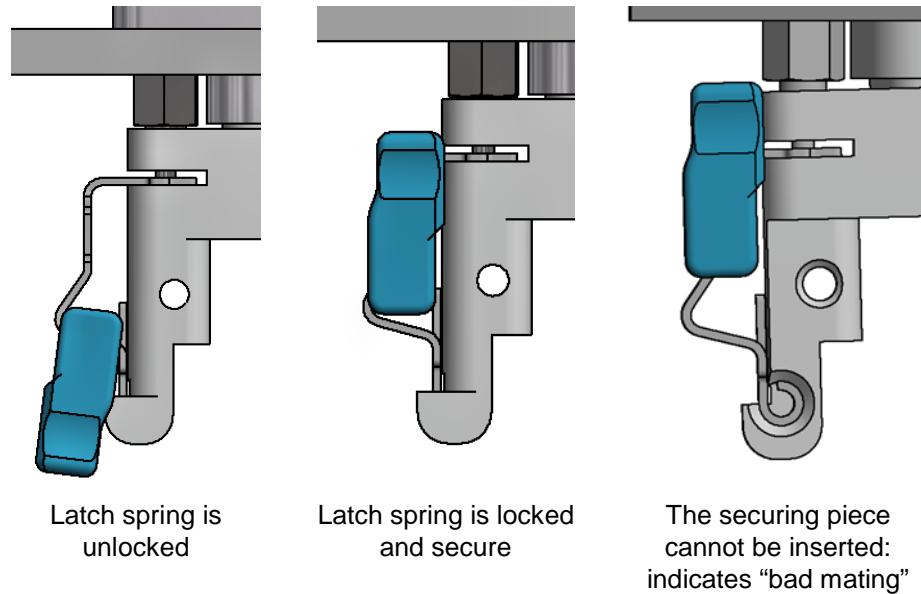
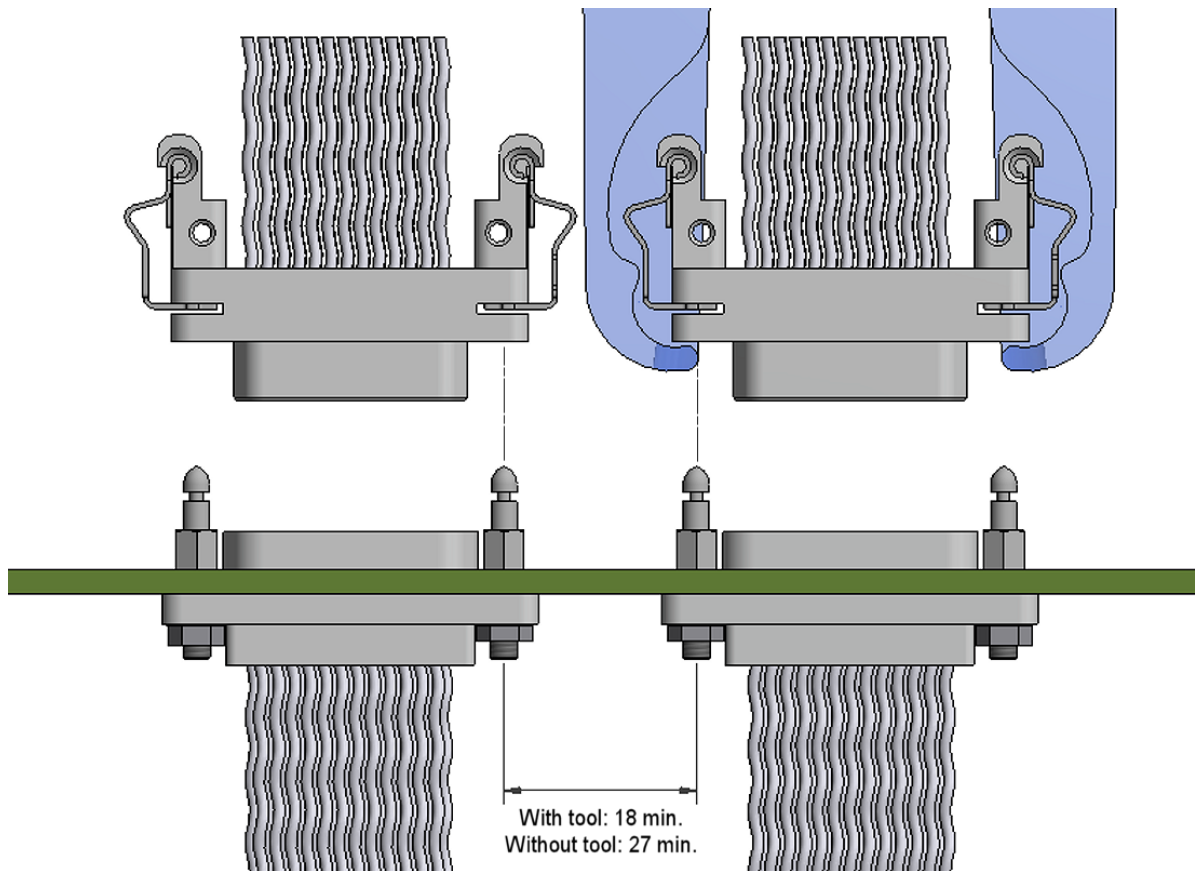

FIGURE 2.3 – HORIZONTAL AND VERTICAL SPACING

FIGURE 2.3.1 – HORIZONTAL MINIMUM SPACING



NOTES:

1. All dimensions are in millimetres.

FIGURE 2.3.2 – VERTICAL RECOMMENDED SPACING

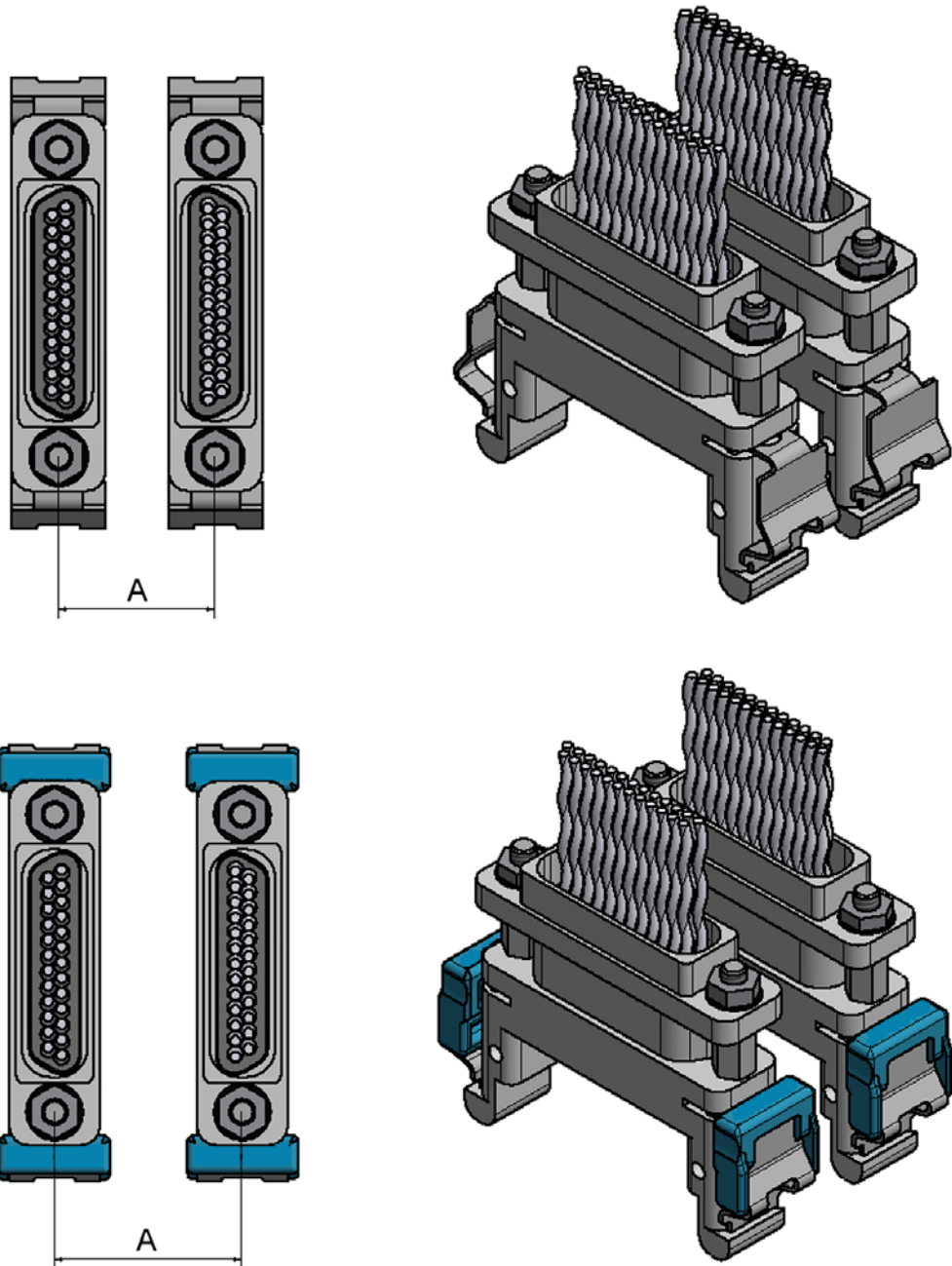

Symbol	Dimensions mm	Remarks
A	12.5	Without securing piece
	15.5	With securing piece

FIGURE 2.4 – PANEL MOUNT

FIGURE 2.4.1 – LATCH POSTS FOR PANEL MOUNT

Panel-Mount Latch Post
Applicable to Variants 02, 07, 09

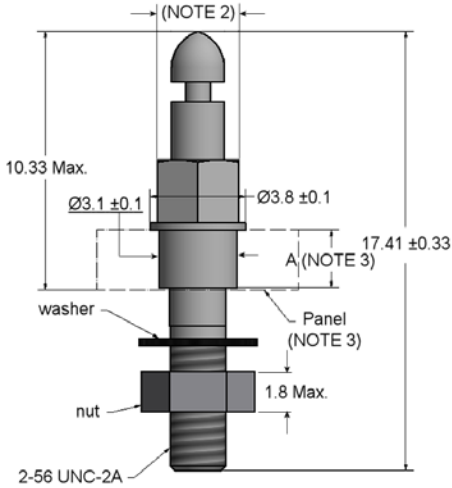

Panel-Mount Latch Post
Applicable to Variants 03, 06

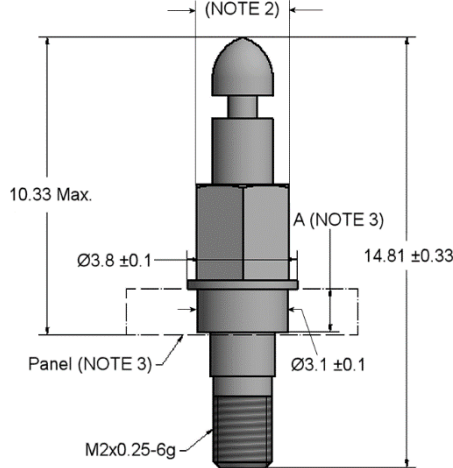

Panel-Mount Latch Post
Applicable to Variants 04, 05

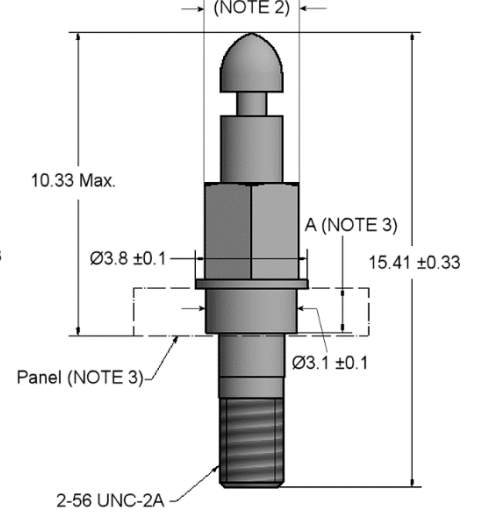

NOTES:

1. All dimensions are in millimetres.
2. Hex. 3.2mm.
3. 5 panel thickness options are available, see Paras. 4.5.3.1.4 and 4.5.3.2.6. Dimension A is dependent on panel thickness T as follows:

T (-0, +0.2)	0.8	1.2	1.6	2	2.4
A	0.65 Min. 0.75 Max.	1.05 Min. 1.15 Max.	1.45 Min. 1.55 Max.	1.85 Min. 1.95 Max.	2.25 Min. 2.35 Max.

FIGURE 2.4.2 – PANEL CUTOUT

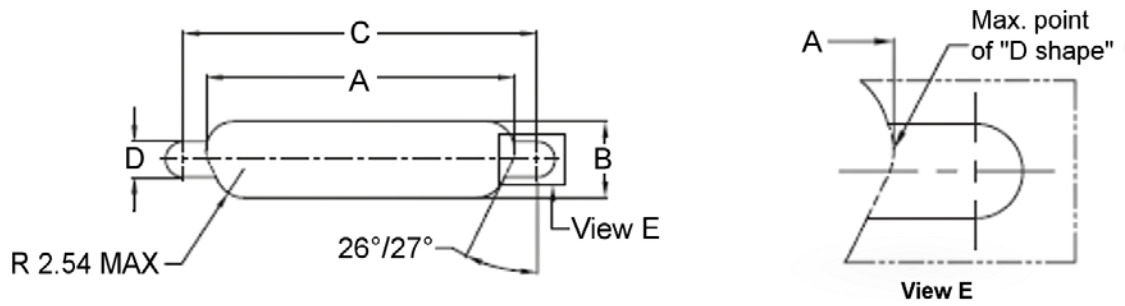

Shell Size	A		B		C		D	
	Min.	Max.	Min.	Max.	Min.	Max.	Min.	Max.
9	10.36	10.46	6.55	6.65	14.48	14.61	3.25	3.38
15	14.2	14.3	6.55	6.65	18.29	18.42	3.25	3.38
21	18	18.1	6.55	6.65	22.1	22.23	3.25	3.38
25	20.55	20.65	6.55	6.65	24.64	24.77	3.25	3.38
31	24.36	24.46	6.55	6.65	28.45	28.58	3.25	3.38
37	28.17	28.27	6.55	6.65	32.26	32.39	3.25	3.38

NOTES:

1. All dimensions are in millimetres.

FIGURE 2.5 - CONTACT POSITIONS

FIGURE 2.5.1 - MOUNTING CONDITION

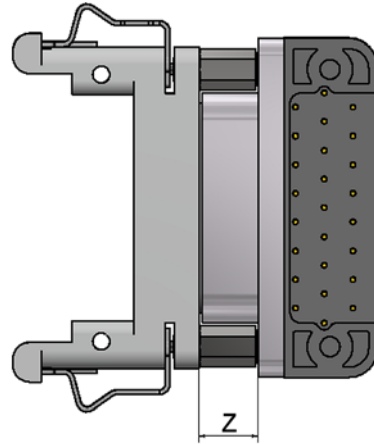

FIGURE 2.5.2 - PLUG MALE CONTACT

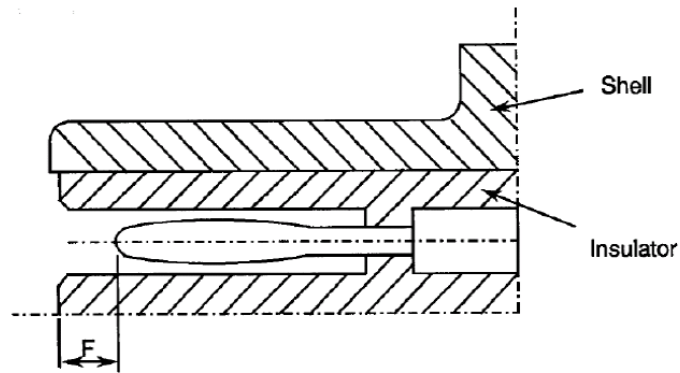
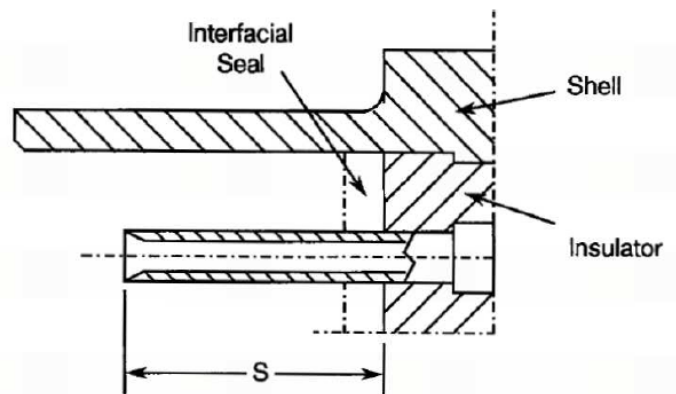
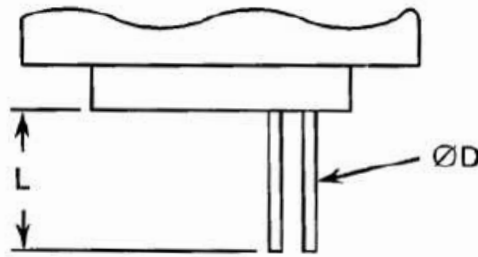

FIGURE 2.5.3 - RECEPTACLE FEMALE CONTACT



F (mm)		S (mm)		Z (mm)
Min.	Max.	Min.	Max.	Max.
0.25	0.91	3.3	3.66	5.33

FIGURE 2.6 - UNINSULATED SOLID WIRE FOR PCB VARIANTS



Wire Size (AWG)	25
Maximum Diameter D (mm)	0.51
Minimum Diameter D (mm)	0.4
Maximum Weight (g/m)	1.6
Minimum Length L	See Para. 4.5.3.1.3

FIGURE 2.7 - INSULATED WIRE

		Insulated Wire Detail Specifications and Variant Numbers				
		ESCC 3901/002		ESCC 3901/012		ESCC 3901/013
		56	61	03	02	01
Conductor Characteristics	Maximum Diameter (mm)	0.53	0.43	0.53	0.5	0.42
	Nominal Cross-section (mm ²)	0.15	0.1	0.15	0.14	0.089
Wire Characteristics	Maximum Diameter (mm)	0.78	0.68	0.86	0.89	0.82
	Maximum Weight (g/m)	1.93	1.23	2.11	2.3	1.8
	Minimum Length L	See Paras. 4.5.3.1.3 and 4.5.3.2.5				

		Insulated Wire Detail Specifications and Variant Numbers					
		ESCC 3901/018		ESCC 3901/019		ESCC 3901/024	
		03	04	02	03	02	03
Conductor Characteristics	Maximum Diameter (mm)	0.39	0.49	0.47	0.57	0.39	0.47
	Nominal Cross-section (mm ²)	0.089	0.14	0.09	0.15	0.09	0.15
Wire Characteristics	Maximum Diameter (mm)	0.9	1.03	0.87	0.96	0.85	1
	Maximum Weight (g/m)	1.81	2.68	1.4	1.9	1.7	2.2
	Minimum Length L	See Paras. 4.5.3.1.3 and 4.5.3.2.5					

FIGURE 3 - CONTACT ARRANGEMENTS

FRONT VIEW OF MALE INSERT - USE MIRROR VIEW FOR FEMALE INSERT

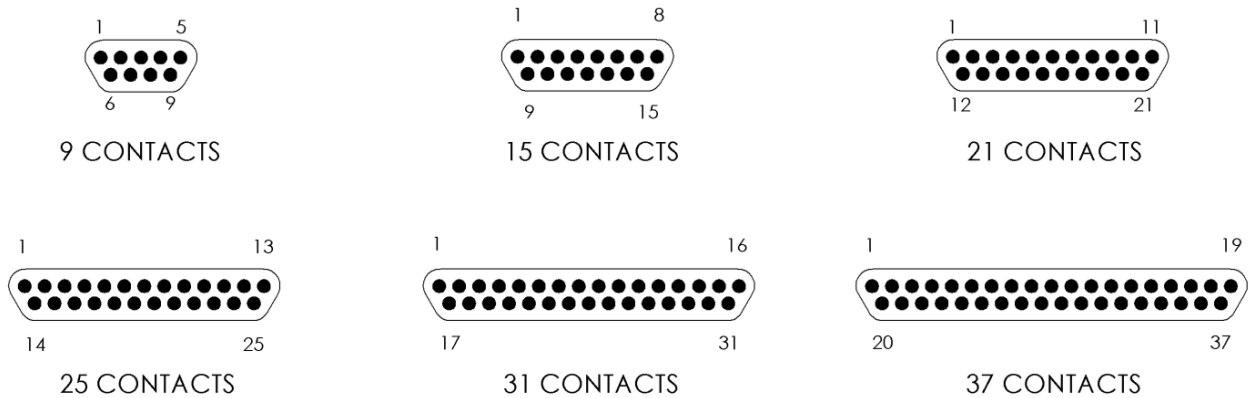

NOTES:

1. Only the outside contact cavities on each row are identified in the drawing, the remainder follow sequentially. Contact numbers are shown outside the insert for readability.

CONTACT CENTRES

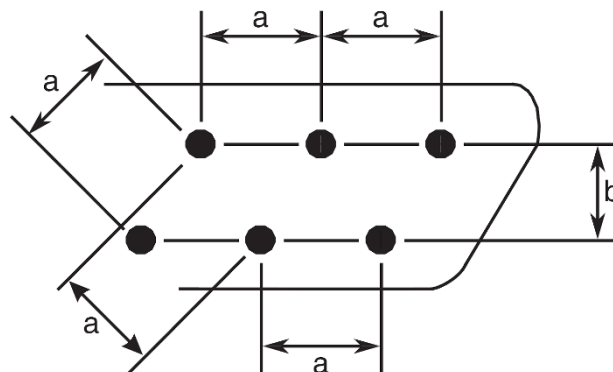

NOTES:

1. a = Distance between contact centres: 1.27mm (typical).
2. b = Distance between rows: 1.09mm (typical).

2 APPLICABLE DOCUMENTS

The following documents form part of this specification and shall be read in conjunction with it:

- (a) ESCC Generic Specification No. [3401](#), Connectors, Electrical, Circular and Rectangular.
- (b) ESCC Detail Specification No. [3401/029](#), Connectors, Electrical, Rectangular, Microminiature, Based on Type MDM.
- (c) ESCC Detail Specification No. [3901/002](#), Polyimide Insulated Wires and Cables, Low Frequency, 600V, -100 to +200°C.
- (d) ESCC Detail Specification No. [3901/012](#), Extruded, Cross-linked Fluoropolymer Insulated Wires and Cables on Silver-Plated Copper Conductor, Low Frequency, 600V, -100 to +200°C.
- (e) ESCC Detail Specification No. [3901/013](#), PTFE Insulated Wires and Cables, 600V, -100 to +200°C.
- (f) ESCC Detail Specification No. [3901/018](#), Polyimide/Fluorothermoplast Insulated Wires and Cables, Low Frequency, 600V, -200 to +200°C, Based on Type SPM.
- (g) ESCC Detail Specification No. [3901/019](#), Polyimide Insulated Wires and Cables, Low Frequency, 600V, -200 to +200 °C, Based on Type SPL.
- (h) ESCC Detail Specification No. [3901/024](#), Fluoropolymer Insulated Wires and Cables, Low Frequency, 600V, -200 to +200 °C, Based on Type CSWL.
- (i) A-A-59551, Wire, Electrical, Copper (Uninsulated).
- (j) MIL-DTL-45204, Gold Plating, Electro-deposited.
- (k) SAE-AMS-2418, Copper Plating.
- (l) MIL-M-24519, Molding Plastics, Electrical, Thermoplastic.
- (m) [MIL-DTL-83513](#), Connectors Electrical, Rectangular, Microminiature, Polarised Shell, General Specification for.

3 TERMS, DEFINITIONS, ABBREVIATIONS, SYMBOLS AND UNITS

For the purpose of this specification, the terms, definitions, abbreviations, symbols and units specified in ESCC Basic Specification No. [21300](#) shall apply. In addition the following terms are used:

- Jumper: Two connectors (either two plugs or one plug and one receptacle) of the same number of ways (n), wired together with n wires (per one of six ESCC Detail Specifications, listed herein) of the same, specified, length.
- Latch Post: One component part of the quick-locking system, mates with a Latch Spring. Available as a standard type and as three different panel-mount types.
- Latch Spring: One component part of the quick-locking system, mates with a Latch Post.
- Potting: Epoxy compound used as an encapsulant.

4 REQUIREMENTS

4.1 GENERAL

The complete requirements for procurement of the connectors specified herein are stated in this specification and ESCC Generic Specification No. [3401](#). Deviations from the Generic Specification, applicable to this specification only, are listed in Para. 4.2.

Deviations from the applicable Generic Specification and this Detail Specification, formally agreed with specific Manufacturers on the basis that the alternative requirements are equivalent to the ESCC requirements and do not affect the components' reliability, are listed in the appendices attached to this specification.

4.2 DEVIATIONS FROM GENERIC SPECIFICATION

4.2.1 Deviations from Special In-Process Controls

Para. 9.15, Joint strength: the contacts shall be crimped to insulated stranded wire AWG26 and AWG28, and to uninsulated solid wire AWG25. The value of failure shall be recorded together with the information as to whether the failure was 'pull-out', 'break in crimp' or 'break in wire'. The minimum tensile strength shall be as follows:

Wire	Male and Female Contacts		
	AWG26	AWG28	AWG25 - Solid Uninsulated
Tensile Strength (N)	22	13	22

4.2.2 Deviations from Final Production Tests (Chart II)

- (a) Para. 9.4, Contact Capability: this test shall be performed on the male contacts. For details see Para. 4.3.3 of this specification.
- (b) Para. 9.5, Magnetism Level: Not applicable.

4.2.3 Deviations from Burn-in and Electrical Measurements (Chart III)

None (Chart III is not applicable).

4.2.4 Deviations from Qualification Tests (Chart IV)

- (a) Para. 9.15, Joint Strength: Not applicable.
- (b) Para. 9.17, Contact Retention (in insert): Not applicable with male contact.
- (c) Para. 9.27, Maintenance Aging: Not applicable.
- (d) Para. 9.29, Oversize Pin Exclusion: Not applicable.
- (e) Para. 9.30, Probe Damage: Not applicable.
- (f) Para. 9.31, Solderability: Not applicable.

4.2.5 Deviations from Lot Acceptance Tests (Chart V)

- (a) Para. 9.15, Joint Strength: Not applicable.
- (b) Para. 9.17, Contact Retention (in insert): Not applicable with male contact.
- (c) Para. 9.27, Maintenance Aging: Not applicable.
- (d) Para. 9.29, Oversize Pin Exclusion: Not applicable.
- (e) Para. 9.30, Probe Damage: Not applicable.

4.3 MECHANICAL REQUIREMENTS

4.3.1 Dimension Check

The dimensions of the connectors specified herein shall be verified in accordance with the requirements set out in Para. 9.6 of ESCC Generic Specification No. 3401 and shall conform to those shown in Figure 2 of this specification. Only the underlined dimensions shall be checked during procurement.

4.3.2 Weight

The maximum weight of the connectors specified herein shall be calculated on the basis of, and be in accordance with the values given in Table 1(a) and in Figures 2.6 and 2.7 of this specification.

4.3.3 Contact Capability

For the purpose of this test, the pick-up and drop weights shall be as follows:

Measurements	Pick-Up Weight	Drop Weight
Weight (g)	14	170
Inner Gauge Diameter (mm) (1)	0.582 - 0.587	0.559 - 0.564
Insertion Depth (mm)	1.5	1.5

NOTES:

1. See Figure 4 for ØA.

4.3.4 Contact Retention (in Insert)

Contact retention within the insert shall be 22.25N. There shall be no displacement of the contact. Not applicable to male contacts.

4.3.5 Mating and Unmating Forces

The forces applied for the mating and unmating of the connectors shall conform to the values specified in Table 1(a).

4.3.6 Insert Retention (in Shell)

Connector inserts shall withstand a pressure of 34.4N/cm² applied from the mating side to the rear side.

4.3.7 Jackscrew Retention

Not applicable.

4.3.8 Contact Insertion and Withdrawal Forces

Not applicable.

4.3.9 Engagement and Separation Forces (Male Contacts)

The contact engagement and separation forces of the male contacts shall be tested to a depth of 1.5mm with the applicable test gauge fixtures specified in Figure 4 of this specification, and shall not exceed the values of the table hereunder.

Measurements	Inner Diameter (mm)		Separation Force Min. (N)	Engagement Force Max. (N)
	Min.	Max.		
Minimum Diameter Test Sleeve	0.559	0.564	-	1.667
Maximum Diameter Test Sleeve	0.582	0.587	0.137	-

4.3.10 Oversize Pin Exclusion

Not applicable.

4.3.11 Probe Damage

Not applicable.

4.3.12 Solderability

Not applicable.

4.4 MATERIALS AND FINISHES

The materials and finishes shall be as specified herein. Where a definite material is not specified, a material which will enable the components specified herein to meet the performance requirements of this specification shall be used. Acceptance or approval of any constituent material does not guarantee acceptance of the finished product.

4.4.1 Shell

The shell shall be made of aluminium alloy. The plating shall be 15µm minimum of electroless nickel.

4.4.2 Insert

The insert shall be made of glass fibre-filled liquid crystal polymer in accordance with MIL-M-24519.

4.4.3 Contacts

4.4.3.1 *Female Contact*

The contact body material and finish shall either be copper alloy with an underplate of 1µm minimum of copper to SAE-AMS 2418, gold plated with 1.27µm minimum of gold Type 2 Grade C of MIL-DTL-45204, or Type N2 with underplating in accordance with Para 3.3 note 3(b) of ESCC Basic Specification No. [23500](#). Measurement of thickness shall be performed at a distance of 1.5mm from the engagement end.

4.4.3.2 *Male Contact*

The contact body and the bundle material and finish shall either be copper alloy with an underplate of 1µm minimum of copper to SAE-AMS 2418, gold plated with 1.27µm minimum of gold Type 2 Grade C of MIL-DTL-45204, or Type M2 with underplating in accordance with Para 3.3 note 3(b) of ESCC Basic Specification No. [23500](#). Measurement of thickness shall be performed at a distance of 1.5mm from the engagement end.

4.4.4 Interfacial Seal

The interfacial seal shall be made of silicon base rubber.

4.4.5 Insulated Wire

Wire materials and finishes shall be in accordance with the requirements specified in Para. 4.4 of ESCC Detail Specifications No. [3901/002](#), [3901/012](#), [3901/013](#), [3901/018](#), [3901/019](#) and [3901/024](#).

4.4.6 Uninsulated Solid Wire

Uninsulated solid wire material and finish shall either be copper alloy in accordance with Type S as specified in A-A-59551, gold-plated in accordance with Class 00 (i.e. thickness 0.5µm minimum) Grade C or D as specified in MIL-DTL-45204, or Type A14 (except the thickness of the gold plating shall be 0.25µm minimum) in accordance with ESCC Basic Specification No. [23500](#).

4.4.7 Rear Potting

The rear potting shall be made of epoxy resin.

4.4.8 Latch Springs

Latch springs shall be made of beryllium-copper alloy. The plating shall be 4µm minimum of electroless nickel.

4.4.9 Latch Posts

Latch posts shall be made of passivated stainless steel.

4.4.10 Securing Pieces

Securing pieces shall be made of PEEK+PTFE with 30% reinforced carbon fibre.

4.5 MARKING

4.5.1 General

The marking of all components delivered to this specification shall be in accordance with the requirements of ESCC Basic Specification No. 21700 and the following paragraphs.

Each component shall be marked in respect of:

- (a) The ESCC Component Number.
- (b) Characteristics.
- (c) Traceability Information.

4.5.2 The ESCC Component Number

Each component shall bear the ESCC Component Number which shall be constituted and marked as follows:

340109101B

- Detail Specification Number: 3401091
- Type Variant (See Table 1(a)): 01
- Testing Level: B

4.5.3 Characteristics

4.5.3.1 *Characteristics Applicable to Variants 01 to 06*

The characteristics to be marked in the following order of precedence are:

- (a) Shell Size.
- (b) Contact Type.
- (c) Termination Type.
- (d) Mounting.

The information shall be constituted and marked as follows:

Example: 37P01301L150B

- Shell Size: 37
- Contact Type: P
- Termination Type: 01301L150
- Mounting: B

4.5.3.1.1 Shell Size

Shell size shall be designated by the number of contacts.

Specified numbers are: 9, 15, 21, 25, 31 and 37.

4.5.3.1.2 Contact Type

Contact types shall be indicated by the following code letters.

Code Letter	Contact Type
P	Male
S	Female

4.5.3.1.3 Termination Type

Codes defining the termination type and length according to Figures 2.1A to 2.1L are specified as follows:

- Pigtails (Variants 01 and 02)
Example: 01301L150
 - ESCC Detail Specification No. [3901/013](#): 013
 - Variant Number: 01
 - Length of Wire (150cm): L150

The ESCC Detail Specification No. and Variant shall be designated by the following code numbers:

Code Number	Description
00256	ESCC 3901/002 , Variant 56
00261	ESCC 3901/002 , Variant 61
01203	ESCC 3901/012 , Variant 03
01301	ESCC 3901/013 , Variant 01
01302	ESCC 3901/013 , Variant 02
01803	ESCC 3901/018 , Variant 03
01804	ESCC 3901/018 , Variant 04
01902	ESCC 3901/019 , Variant 02
01903	ESCC 3901/019 , Variant 03
02402	ESCC 3901/024 , Variant 02
02403	ESCC 3901/024 , Variant 03

The Length of Wire must be specified, in centimetres, and must be 5cm or longer. The tolerance on the length (L) is as follows:

L (cm)	L<010	010≤L≤100	L>100
Tolerance (cm)	-0/+0.5	-0/+3	-0/+0.5

- PCB Tails (Variants 03 to 06)
The length of the PCB tails shall be indicated by the following code letters.

Code Letter	Tail Length (±0.38mm)
A	2.8
B	3.8
C	4.8
D	6.35

4.5.3.1.4 Mounting

Codes defining the standard hardware and panel mount hardware, and the compatible Variants, are specified as follows:

- **Standard Hardware**

The standard hardware options shall be indicated by the following code letters.

Code Letter	Variant	Description
B	01	Connector with Latch Springs, no Securing Pieces
S	01	Connector with Latch Springs and Securing Pieces
P	02 to 06	Connector with Latch Posts
W	03 to 06	Connector with Latch Posts and Threaded Mounting Inserts

- **Panel Mount Hardware**

The panel mount hardware options shall be indicated by the following code letters.

Code Letter	Variant	Description
P1	02 to 06	Connector with Panel Mount (thickness 0.8mm) Latch Posts
P2	02 to 06	Connector with Panel Mount (thickness 1.2mm) Latch Posts
P3	02 to 06	Connector with Panel Mount (thickness 1.6mm) Latch Posts
P4	02 to 06	Connector with Panel Mount (thickness 2mm) Latch Posts
P5	02 to 06	Connector with Panel Mount (thickness 2.4mm) Latch Posts
W1	03 to 06	Connector with Panel Mount (thickness 0.8mm) Latch Posts and Threaded Mounting Inserts
W2	03 to 06	Connector with Panel Mount (thickness 1.2mm) Latch Posts and Threaded Mounting Inserts
W3	03 to 06	Connector with Panel Mount (thickness 1.6mm) Latch Posts and Threaded Mounting Inserts
W4	03 to 06	Connector with Panel Mount (thickness 2mm) Latch Posts and Threaded Mounting Inserts
W5	03 to 06	Connector with Panel Mount (thickness 2.4mm) Latch Posts and Threaded Mounting Inserts

4.5.3.2 Characteristics Applicable to Variants 07 to 09

The characteristics to be marked in the following order of precedence are:

- (a) Shell Size.
- (b) Jumper Type.
- (c) Wiring Method.
- (d) Wire Type.
- (e) Length of Wire.
- (f) Hardware.

The information shall be constituted and marked as follows:

Example: 37PSD01803L050SP

- Shell Size: 37
- Jumper Type: PS
- Wiring Method: D
- Wire Type: 01803
- Length of Wire: L050
- Hardware (1st Connector): S
- Hardware (2nd Connector): P

4.5.3.2.1 Shell Size

Shell size shall be designated by the number of contacts.

Specified numbers are: 9, 15, 21, 25, 31 and 37.

4.5.3.2.2 Jumper Type

Jumper types shall be indicated by the following code letters.

Code Letter	Jumper Type
PS	Male-Female
PP	Male-Male

4.5.3.2.3 Wiring Method

Two wiring methods are available; they are codified and indicated as follows:

Code Letter	Wiring Method
I	Indirect Wiring
D	Direct Wiring

Note that indirectly-wired PP Jumpers and directly-wired PS Jumpers have straight, "flat", wiring and therefore have no cross-overs. The table below details the wiring configurations for indirectly-wired PP Jumpers:

Shell Size	Connector	Pin Numbers															
		1	2	3	4	5	6	7	8	9	10	11	12	13	14	15	16
9	1 st Connector	1	2	3	4	5	6	7	8	9	/	/	/	/	/	/	
	2 nd Connector	5	4	3	2	1	9	8	7	6	/	/	/	/	/	/	
15	1 st Connector	1	2	3	4	5	6	7	8	9	10	11	12	13	14	15	
	2 nd Connector	8	7	6	5	4	3	2	1	15	14	13	12	11	10	9	
21	1 st Connector	1	2	3	.	.	9	10	11	12	13	14	.	.	19	20	21
	2 nd Connector	11	10	9	.	.	3	2	1	21	20	19	.	.	14	13	12
25	1 st Connector	1	2	3	.	.	11	12	13	14	15	16	.	.	23	24	25
	2 nd Connector	13	12	11	.	.	3	2	1	25	24	23	.	.	16	15	14
31	1 st Connector	1	2	3	.	.	14	15	16	17	18	19	.	.	29	30	31
	2 nd Connector	16	15	14	.	.	3	2	1	31	30	29	.	.	19	18	17
37	1 st Connector	1	2	3	.	.	17	18	19	20	21	22	.	.	35	36	37
	2 nd Connector	19	18	17	.	.	3	2	1	37	36	35	.	.	22	21	20

4.5.3.2.4 Wire Type

Example: 01803

- ESCC Detail Specification No. [3901/018](#): 018
- Variant Number: 03

Codes defining the wire type are specified as follows:

Code Number	Description
00256	ESCC 3901/002 , Variant 56
00261	ESCC 3901/002 , Variant 61
01203	ESCC 3901/012 , Variant 03
01301	ESCC 3901/013 , Variant 01
01302	ESCC 3901/013 , Variant 02
01803	ESCC 3901/018 , Variant 03
01804	ESCC 3901/018 , Variant 04
01902	ESCC 3901/019 , Variant 02
01903	ESCC 3901/019 , Variant 03
02402	ESCC 3901/024 , Variant 02
02403	ESCC 3901/024 , Variant 03

4.5.3.2.5 Length of Wire

Example (50cm): L050

The Length of Wire must be specified, in centimetres, and must be 5cm or longer. The tolerance on the length (L) is as follows:

L (cm)	L<010	010≤L≤100	L>100
Tolerance (cm)	-0/+0.5	-0/+3	-0/+0.5

4.5.3.2.6 Hardware

The following details apply to both the 1st Connector and the 2nd Connector. Note that the 1st Connector is always Male (see Para. 4.5.3.2.2, Jumper Type).

- Standard Hardware

The standard hardware options, and the compatible Variants, shall be indicated by the following code letters.

Code Letter	Variant	Description
B	07, 08	Connector with Latch Springs, no Securing Pieces
S	07, 08	Connector with Latch Springs and Securing Pieces
P	07, 09	Connector with Latch Posts

- Panel Mount Hardware

The panel mount hardware options, and the compatible Variants, shall be indicated by the following code letters.

Code Letter	Variant	Description
P1	07, 09	Connector with Panel Mount (thickness 0.8mm) Latch Posts
P2	07, 09	Connector with Panel Mount (thickness 1.2mm) Latch Posts
P3	07, 09	Connector with Panel Mount (thickness 1.6mm) Latch Posts
P4	07, 09	Connector with Panel Mount (thickness 2mm) Latch Posts
P5	07, 09	Connector with Panel Mount (thickness 2.4mm) Latch Posts

4.5.4 Traceability Information

Traceability information shall be marked in accordance with the requirements of ESCC Basic Specification No. [21700](#).

4.6 ELECTRICAL MEASUREMENTS

4.6.1 Electrical Measurements at Room Temperature

The parameters to be measured in respect of electrical characteristics are scheduled in Table 2. Unless otherwise specified, the measurements shall be performed at $T_{amb} = +22 \pm 3^{\circ}C$.

4.6.2 Electrical Measurements at High and Low Temperatures

Not applicable.

4.6.3 Circuits for Electrical Measurements

Not applicable.

4.7 BURN-IN AND ELECTRICAL MEASUREMENTS (TABLES 4 AND 5)

Not applicable.

TABLE 2 - ELECTRICAL MEASUREMENTS AT ROOM TEMPERATURE

No.	Characteristic	Symbol	ESCC 3401 Test Method	Test Condition	Limits		Unit
					Min	Max	
1	Insulation Resistance	R_i	Para. 9.1.1.1	Para. 9.1.1.1	5000	-	$M\Omega$
2	Voltage Proof Leakage Current	I_L	Para. 9.1.1.2	600Vrms	-	2	mA
3	Mated Shell Conductivity (Voltage Drop) (Note 1)	V_D	Para. 9.1.1.4	Para. 9.1.1.4	Not applicable		mV
4	Contact Resistance (Low Level Current)	R_{cl} max.	Para. 9.1.1.3	Para. 9.1.1.3	-	6 (2) 25 (3)	$m\Omega$
5	Contact Resistance (Rated Current)	R_{cr} max.	Para. 9.1.1.3	Table 1(b)	-	5 (2) 25 (3)	$m\Omega$

NOTES:

1. Applicable to mated connectors with grounding option.
2. For Variants 01, 02, 07, 08, 09.
3. For Variants 03 to 06. Measurement of Contact Resistance shall include all parts of the contact including the body and the wire.

TABLES 3, 4 AND 5

Not applicable.

FIGURE 4 - GAUGE FIXTURE

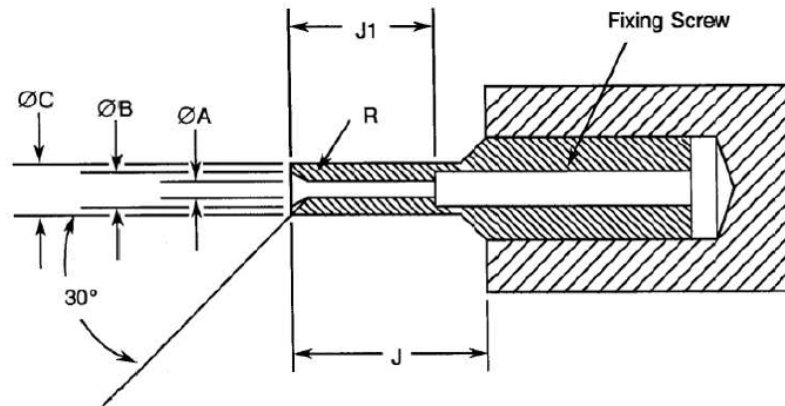

MINIMUM DIAMETER TEST SLEEVE

Weight (g) 170			Remarks
Symbol	Min.	Max.	
ØA	0.559	0.564	Note 2
ØB	0.749	0.775	-
ØC	0.813	0.825	-
J	4	-	-
J1	3.13	3.23	-
R	0.381	0.483	Note 1

MAXIMUM DIAMETER TEST SLEEVE

Weight (g) 14			Remarks
Symbol	Min.	Max.	
ØA	0.582	0.587	Note 2
ØB	0.749	0.775	-
ØC	0.813	0.825	-
J	4	-	-
J1	3.13	3.23	-
R	0.381	0.483	Note 1

NOTES:

1. Radius R, must be tangent to entry chamfer and ØA.
2. ØA and entry chamfer shall have a surface roughness of 3.2µm (roughness grade N8).
3. All dimensions are in millimetres.

- 4.8 ENVIRONMENTAL AND ENDURANCE TESTS (CHARTS IV AND V OF ESCC GENERIC SPECIFICATION No. 3401)
- 4.8.1 Measurements and Inspections on Completion of Environmental Tests
The parameters to be measured and inspections to be performed on completion of environmental testing shall be those specified in Table 6. Unless otherwise specified, these measurements shall be performed at $T_{amb} = +22 \pm 3^{\circ}\text{C}$.
- 4.8.2 Measurements and Inspections at Intermediate Points during Endurance Tests
Not applicable.
- 4.8.3 Measurements and Inspections on Completion of Endurance Tests
The parameters to be measured and inspections to be performed on completion of endurance testing shall be those specified in Table 6. Unless otherwise specified, these measurements shall be performed at $T_{amb} = +22 \pm 3^{\circ}\text{C}$.
- 4.8.4 Conditions for Operating Life Test (Part of Endurance Testing)
Not applicable.
- 4.8.5 Electrical Circuit for Operating Life Test
Not applicable.
- 4.8.6 Conditions for High Temperature Storage Test (Part of Endurance Testing)
The requirements for the high temperature storage test are specified in Section 9 of ESCC Generic Specification No. 3401. The temperature to be applied shall be the maximum storage temperature specified in Table 1(b) of this specification.

TABLE 6 - MEASUREMENTS AND INSPECTIONS ON COMPLETION OF ENVIRONMENTAL AND ENDURANCE TESTING

No.	ESCC Generic Spec. No. 3401		Measurements and Inspections		Symbol	Limits		Unit
	Environmental and Endurance Tests Note 1	Test Method and Conditions	Identification	Conditions		Min	Max	
01	Seal Test	Para. 9.9	ESCC 3401 Para. 9.9	-	-	ESCC 3401 Para. 9.9		-
02	Wiring	Para. 9.10	Low Level Contact Resistance	Table 2 Item 4	R _{cl}	Table 2, Item 4		-
03	Vibration	Para. 9.11	Initial Measurements Coupling screw(s) Unlocking Torque	-	T _{qe}	Not applicable		-
			Final Measurements Full Engagement Coupling screw(s) Unlocking Torque Drift Visual Examination	-	ΔT _{qe} /T _{qe}	Not applicable		%
04	Shock or Bump	Para. 9.12	Full Engagement Visual Examination	-	-	-	-	-
05	Climatic Sequence	Para. 9.13	Dry Heat Insulation Resistance	At High Temperature Table 2, Item 1 (2)	R _i	10	-	MΩ
			Low Air Pressure Voltage Proof Leakage Current	Figure 1	I _L	ESCC 3401 Para. 9.13.5		mA
			Damp Heat Insulation Resistance	Immediately after test Table 2, Item 1	R _i	100	-	MΩ
			Final Measurements External Visual Inspection	After 1-24 hrs Recovery ESCC 3401 Para. 9.7	-	ESCC 3401 Para. 9.7		-
			Insulation Resistance Voltage Proof Leakage Current	Table 2, Item 1 Table 2, Item 2	R _i I _L	Table 2, Item 1 Table 2, Item 2	MΩ mA	
06	Plating Thickness	Para. 9.14	Thickness	-	-	Para. 4.4.3 of this spec.		-
07	Joint Strength (N/A to solder contacts)	Para. 9.15 & Paras. 4.2.4 & 4.2.5 of this spec.	Not applicable	-	-	-		-
08	Rapid Change of Temperature	Para. 9.16	Visual Examination	-	-	-		-
			Insulation Resistance Voltage Proof Leakage Current	Table 2, Item 1 Table 2, Item 2	R _i I _L	Table 2, Item 1 Table 2, Item 2	MΩ mA	
09	Contact Retention (in Insert)	Para. 9.17 & Para. 4.3.4 of this spec.	Contact Displacement	-	-	ESCC 3401 Para. 9.17		-

No.	ESCC Generic Spec. No. 3401		Measurements and Inspections		Symbol	Limits		Unit
	Environmental and Endurance Tests Note 1	Test Method and Conditions	Identification	Conditions		Min	Max	
10	Endurance	Para. 9.18	Initial Measurements Mating/Unmating Forces Low Level Contact Resistance Mated Shell Conductivity Final Measurements Visual Examination Mating/Unmating Forces Low Level Contact Resistance Drift Rated Current Contact Resistance Mated Shell Conductivity Insulation Resistance Voltage Proof Leakage Current	- Table 2, Item 4 Table 2, Item 3 - - Table 2, Item 4 Table 2, Item 5 Table 2 Item 3 Table 2 Item 1 Table 2 Item 2	F R _{cl} V _D - F ΔR _{cl} R _{cr} V _D R _i I _L	Para. 4.3.5 of this spec. Record Values Not applicable - - Para. 4.3.5 of this spec - 3 Table 2, Item 5 Not applicable Table 2, Item 1 Table 2, Item 2	N mΩ mV N mΩ mΩ mV MΩ mA	
11	Permanence of Marking	Para. 9.19	-	-	-	-	-	-
12	Mating/Unmating Forces	Para. 9.20	Force	-	F	Para. 4.3.5 of this spec	N	
13	High Temperature Storage	Para. 9.21	Initial Measurements Low Level Contact Resistance Mated Shell Conductivity Final Measurements Visual Examination Mating/Unmating Forces Low Level Contact Resistance Drift Rated Current Contact Resistance Mated Shell Conductivity Insulation Resistance Voltage Proof Leakage Current Contact Retention (In insert)	Table 2, Item 4 Table 2, Item 3 - - Table 2, Item 4 Table 2, Item 5 Table 2 Item 3 Table 2 Item 1 Table 2 Item 2 Para. 4.3.4 of this spec.	R _{cl} V _D - F ΔR _{cl} R _{cr} V _D R _i I _L -	Record Values Not applicable - Para. 4.3.5 of this spec - 3 Table 2, Item 5 Not applicable Table 2, Item 1 Table 2, Item 2 ESCC 3401 Para. 9.17	mΩ mV N mΩ mΩ mV MΩ mA -	
14	Corrosion	Para. 9.22	Visual Examination	-	-	- -	-	
15	Insert Retention (in Shell)	Para. 9.23 & Para. 4.3.6 of this spec.	Visual Examination	-	-	Para. 4.3.6 of this spec.	-	

No.	ESCC Generic Spec. No. 3401		Measurements and Inspections		Symbol	Limits		Unit
	Environmental and Endurance Tests Note 1	Test Method and Conditions	Identification	Conditions		Min	Max	
16	Jackscrew Retention	Para. 9.24 & Para. 4.3.7 of this spec	Visual Examination	-	-	Not applicable		-
17	High Temperature Measurements	Para. 9.25	Insulation Resistance	Table 2 Item 1 (2)	R _i	10	-	MΩ
18	Overload Test	Para. 9.26	Internal Temperature	-	T	-	+100	°C
			Rated Current Contact Resistance	Table 2, Item 5	R _{cr}	Table 2, Item 5		mΩ
			Mated Shell Conductivity	Table 2 Item 3	V _D	Not applicable		mV
			Insulation Resistance	Table 2 Item 1	R _i	Table 2, Item 1		MΩ
			Voltage Proof Leakage Current	Table 2 Item 2	I _L	Table 2, Item 2		mA
19	Maintenance Aging	Para. 9.27 & Paras. 4.2.4 & 4.2.5 of this spec	Not applicable	-	-	-	-	-
20	Engage/Separation Forces	Para. 9.28 & Para. 4.3.9 of this spec.	Force	-	F	Para. 4.3.9 of this spec.		N
21	Oversize Pin Exclusion	Para. 9.29 & Para. 4.3.10 of this spec.	Not applicable	-	-	-	-	-
22	Probe Damage	Para. 9.30 & Para. 4.3.11 of this spec.	Not applicable	-	-	-	-	-
23	Solderability	Para. 9.31 & Para. 4.3.12 of this spec.	Not applicable	-	-	-	-	-

NOTES:

1. The tests in this Table refer to either Chart IV or V and shall be used as applicable.
2. T_{amb} = +125°C.