



**RF COAXIAL CONNECTORS, TYPE TNC,  
50 OHMS (MALE CONTACT)**

**ESCC Detail Specification No. 3402/008**

Issue 3	February 2019
---------	---------------



**LEGAL DISCLAIMER AND COPYRIGHT**

European Space Agency, Copyright © 2019. All rights reserved.

The European Space Agency disclaims any liability or responsibility, to any person or entity, with respect to any loss or damage caused, or alleged to be caused, directly or indirectly by the use and application of this ESCC publication.

This publication, without the prior permission of the European Space Agency and provided that it is not used for a commercial purpose, may be:

- copied in whole, in any medium, without alteration or modification.
- copied in part, in any medium, provided that the ESCC document identification, comprising the ESCC symbol, document number and document issue, is removed.

**DOCUMENTATION CHANGE NOTICE**

(Refer to <https://escies.org> for ESCC DCR content)

DCR No.	CHANGE DESCRIPTION
1194	Specification upissued to incorporate changes per DCR.

**TABLE OF CONTENTS**

1	GENERAL	6
1.1	SCOPE	6
1.2	TYPE VARIANTS	6
1.3	MAXIMUM RATINGS	6
1.4	PARAMETER DERATING INFORMATION (FIGURE 1)	6
1.5	PHYSICAL DIMENSIONS	6
1.6	STANDARD TEST CONNECTOR INTERFACE	6
2	APPLICABLE DOCUMENTS	16
3	TERMS, DEFINITIONS, ABBREVIATIONS, SYMBOLS AND UNITS	16
4	REQUIREMENTS	16
4.1	GENERAL	16
4.2	DEVIATIONS FROM GENERIC SPECIFICATION	16
4.2.1	Deviations from Special In-process Controls	16
4.2.2	Deviations from Final Production Tests (Chart II)	16
4.2.3	Deviations from Burn-in Tests (Chart III)	16
4.2.4	Deviations from Qualification Tests (Chart IV)	16
4.2.5	Deviations from Lot Acceptance Tests (Chart V)	16
4.3	MECHANICAL REQUIREMENTS	16
4.3.1	Dimension Check	16
4.3.2	Weight	16
4.3.3	Coupling Proof Torque	17
4.3.4	Cable Retention Force	17
4.3.4.1	Flexible Cables	17
4.3.4.2	Semi-rigid Cables	17
4.3.5	Mating and Unmating Forces	17
4.3.6	Endurance	17
4.3.7	Residual Magnetism	17
4.3.8	Contact Engagement and Separation Forces	18
4.3.9	Contact Retention	18
4.4	MATERIALS AND FINISHES	18
4.4.1	Shell, Coupling Nut	18
4.4.2	Centre Contact	19
4.4.3	Inserts	19
4.4.4	Gaskets	19
4.4.5	Accessories	19
4.5	MARKING	19

4.5.1	General	19
4.5.2	The ESCC Component Number	19
4.5.3	Characteristics	20
4.5.3.1	Variants of Fixed Configuration	20
4.5.3.2	Variants where Dimensions A and B of Figure 2(b) are indicated by a Maximum Only	20
4.5.3.3	Type of Plating/Material	20
4.5.3.4	Length Values	21
4.5.3.5	Tolerance	21
4.5.4	Traceability Information	21
4.5.5	Marking of Small Components	21
4.6	ELECTRICAL MEASUREMENTS	21
4.6.1	Electrical Measurements at Room Temperature	21
4.6.2	Electrical Measurements at High and Low Temperatures (Table 3)	21
4.6.3	Circuits for Electrical Measurements	21
4.7	BURN-IN TESTS (TABLES 4 AND 5)	21
4.8	ENVIRONMENTAL AND ENDURANCE TESTS	22
4.8.1	Measurements and Inspections on Completion of Environmental Tests	22
4.8.2	Measurements and Inspections at Intermediate Points during Endurance Tests	22
4.8.3	Measurements and Inspections on Completion of Endurance Tests	22
4.8.4	Conditions for Operating Life Tests (Part of Endurance Testing)	22
4.8.5	Electrical Circuits for Operating Life Tests	22
4.8.6	Conditions for High Temperature Storage Test (Part of Endurance Testing)	22

## 1 GENERAL

### 1.1 SCOPE

This specification details the ratings, physical and electrical characteristics, test and inspection data for RF Coaxial Connectors, Type TNC, 50 Ohms (Male Contact). It shall be read in conjunction with ESCC Generic Specification No. [3402](#), the requirements of which are supplemented herein.

### 1.2 TYPE VARIANTS

A list of the type variants of the connectors specified herein, which are also covered by this specification, is given in Table 1(a).

For each type variant, the full electrical and physical characteristics are given in individual Figures 2(b) at the end of this specification.

### 1.3 MAXIMUM RATINGS

The maximum ratings, which shall not be exceeded at any time during use or storage, applicable to the connectors specified herein, are as scheduled in Table 1(b).

### 1.4 PARAMETER DERATING INFORMATION (FIGURE 1)

The derating information applicable to the connectors specified herein is shown in Figure 1.

### 1.5 PHYSICAL DIMENSIONS

The physical dimensions of the connectors specified herein are shown in Figures 2(a) and 2(b).

### 1.6 STANDARD TEST CONNECTOR INTERFACE

Whenever gauges are required for mating with the connectors under test, their physical dimensions shall be in accordance with those specified in Figure 3.

**TABLE 1(a) – TYPE VARIANTS**

Variant	Description
01	Straight Jack, Solder Type, for Semi-Rigid Cable Ø3.58mm (0.141")
02	Straight Plug with Cable Clamp, Solder Type, for Semi-Rigid Cable Ø6.35mm (0.25")
03	Straight Plug, Solder Type for SHF 5 Cable
04	Straight Plug, Solder Type, for SHF 8 Cable
05	Elbow Plug, Solder Type, for SHF 5 Cable
06	Elbow Plug, Solder Type, for SHF 8 Cable
07	Square Flange Male Receptacle

**NOTES:**

1. The Variants are described in Figure 2(b).
2. For finishes, see Para. 4.4.

**TABLE 1(b) - MAXIMUM RATINGS**

No.	Characteristics	Symbol	Maximum Ratings	Unit	Remarks
1	Peak Power at +25°C	P <sub>max</sub>	20	kW	1µs max.
2	Power	P	See Figure 2(b)	kW	See Figures 1(a), 1(b) and 1(c)
3	Nominal Impedance	Z	50	Ω	-
4	Frequency Range	f	See Figure 2(b)	GHz	-
5	Operating Voltage	V <sub>op</sub>	500	V <sub>rms</sub>	-
6	Operating Temperature Range	T <sub>op</sub>	See Figure 2(b)	°C	-
7	Storage Temperature Range	T <sub>stg</sub>	As per Operating Temperature Range	°C	-

**FIGURE 1 - PARAMETER DERATING INFORMATION**

FIGURE 1(a) - POWER VERSUS TEMPERATURE

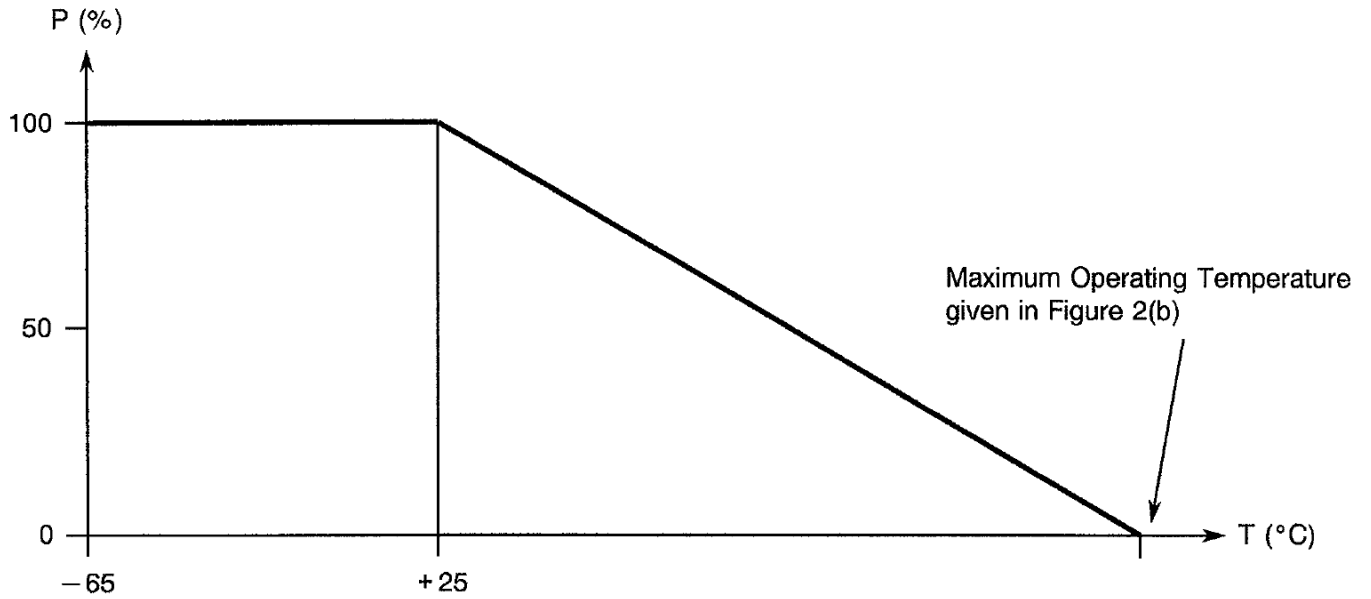
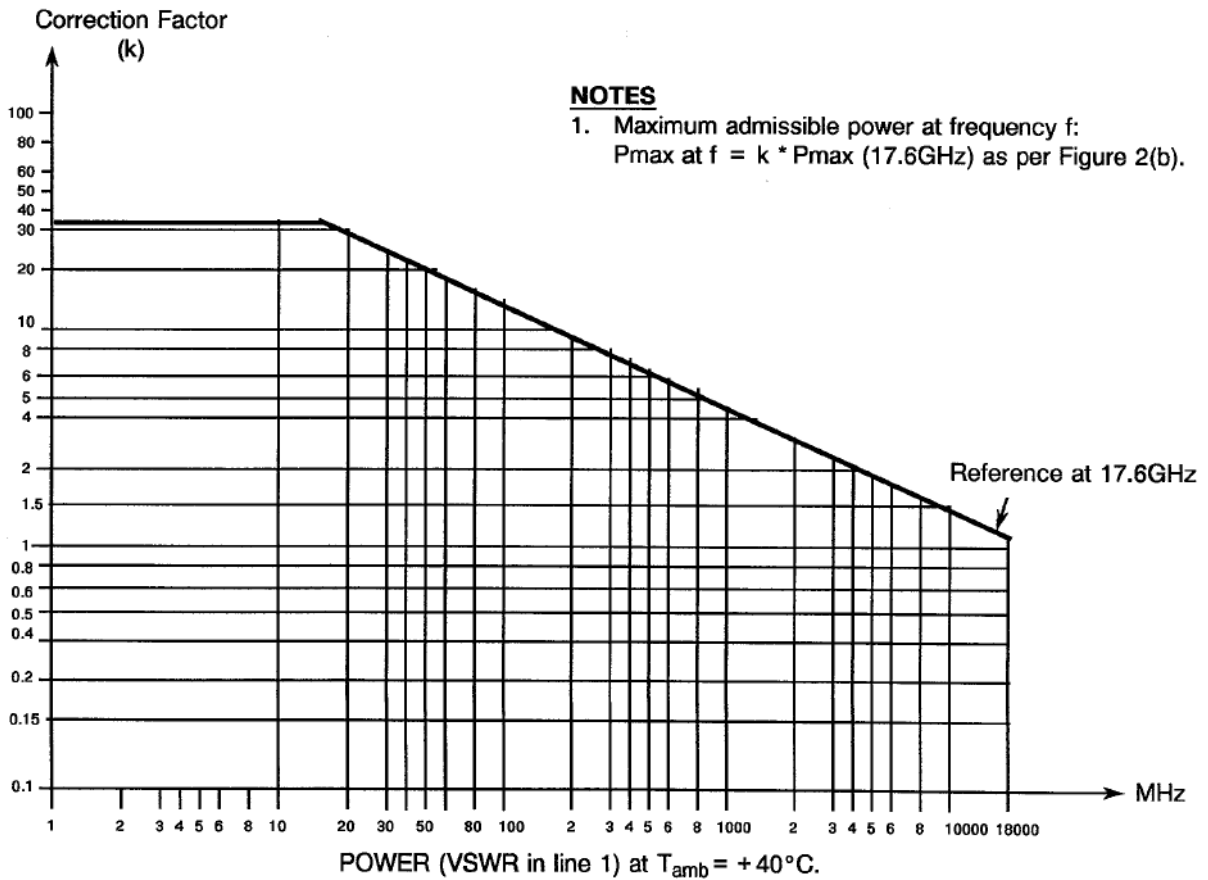
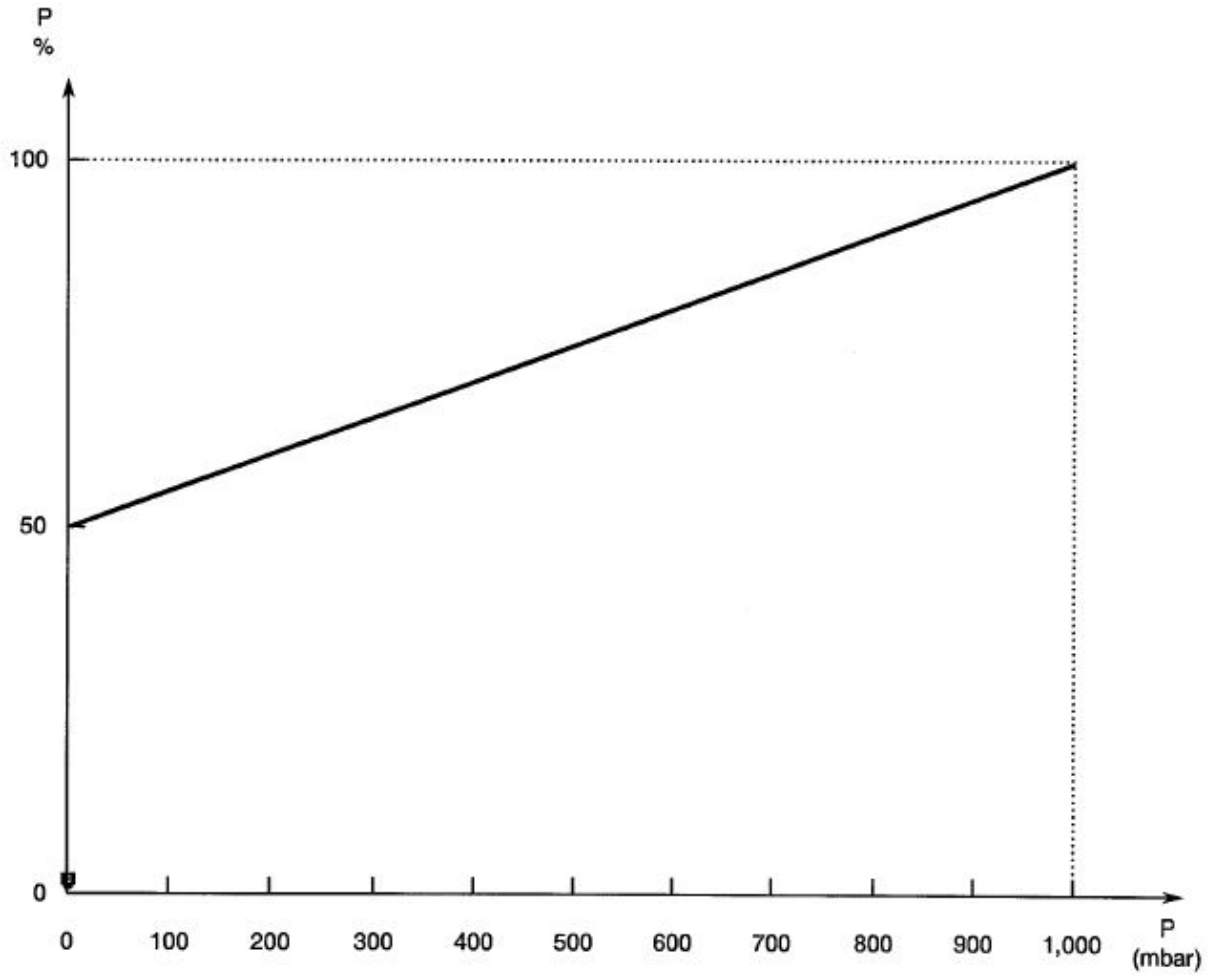

FIGURE 1(b) - POWER VERSUS FREQUENCY

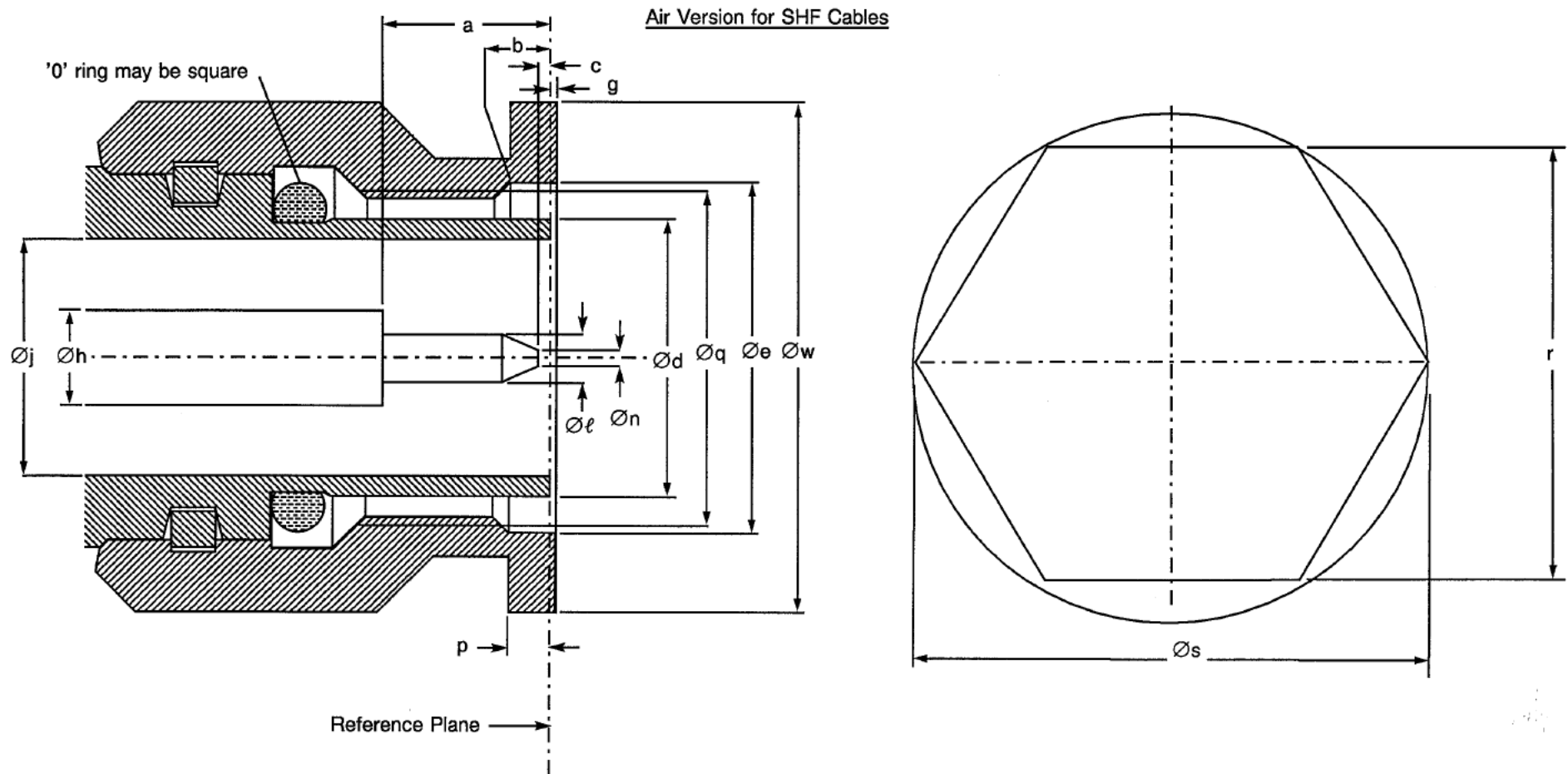



**FIGURE 1 – PARAMETER DERATING INFORMATION (CONTINUED)**FIGURE 1(c) - POWER VERSUS PRESSURE

**FIGURE 2 - PHYSICAL DIMENSIONS**

**FIGURE 2(a) - CONNECTOR INTERFACE, MALE CONTACT**

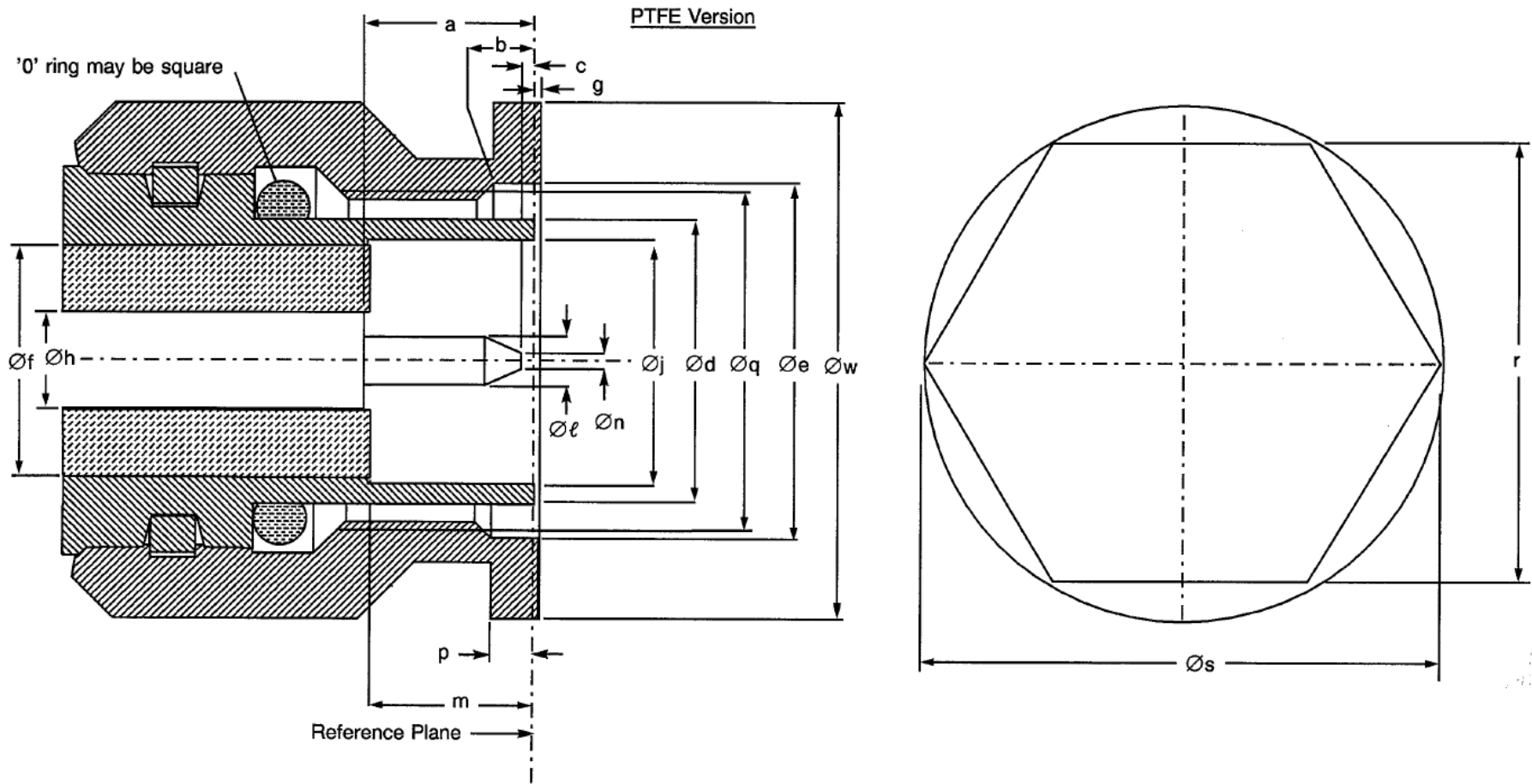

**FIGURE 2 – PHYSICAL DIMENSIONS (CONTINUED)**

**FIGURE 2(a) – CONNECTOR INTERFACE, MALE CONTACT (CONTINUED)**

Symbol	Millimetres		Notes
	Min.	Max.	
a	5.35	5.5	
b	1.5	2.4	
c	0.35	0.9	
Ød	8.03	8.09	
Øe	11.4	11.6	
g	-0.3	+0.55	
Øh	2.68	2.72	
Øj	6.18	6.22	
Øl	1.34	1.36	
Øn	0.35	0.65	
p	1.5	2.4	
Øq	7/16.28 UNEF 2B		
r	-	14	hexagon
Øs	-	16	
Øw	-	16	

**FIGURE 2 - PHYSICAL DIMENSIONS (CONTINUED)**  
**FIGURE 2(a) - CONNECTOR INTERFACE, MALE CONTACT**

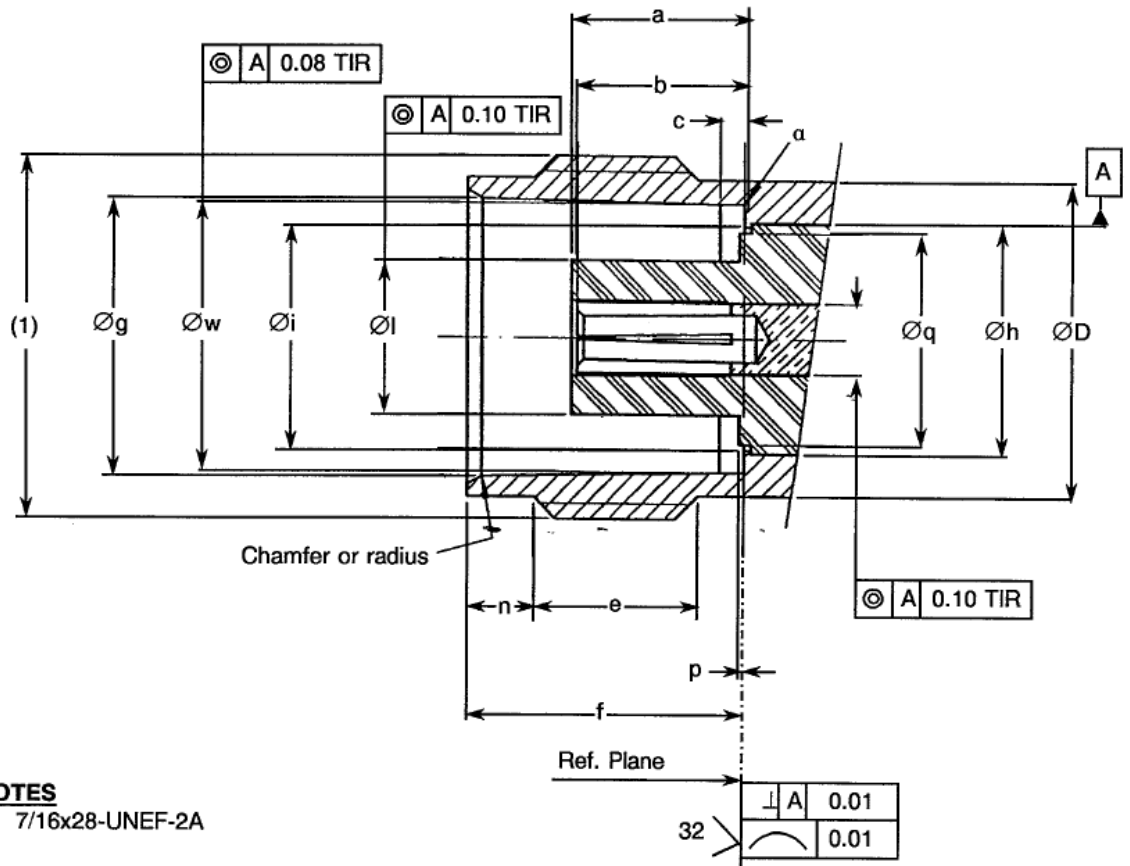

**FIGURE 2 – PHYSICAL DIMENSIONS (CONTINUED)**

**FIGURE 2(a) – CONNECTOR INTERFACE, MALE CONTACT (CONTINUED)**

Symbol	Millimetres		Notes
	Min.	Max.	
a	5.35	5.5	
b	1.5	2.4	
c	0.35	0.9	
Ød	8.03	8.09	
Øe	11.4	11.6	
Øf	5.28	5.32	
g	-0.3	+0.55	
Øh	1.62	1.66	
Øj	6.18	6.22	
Øl	1.34	1.36	
m	5.28	5.38	
Øn	0.35	0.65	
p	1.5	2.4	
Øq	7/16.28 UNEF 2B		
r	-	14	hexagon
Øs	-	16	
Øw	-	16	

**FIGURE 3 - STANDARD TEST CONNECTOR INTERFACE - FEMALE CONTACT**



**NOTES**

1. 7/16x28-UNEF-2A

Detail of Inner Contact

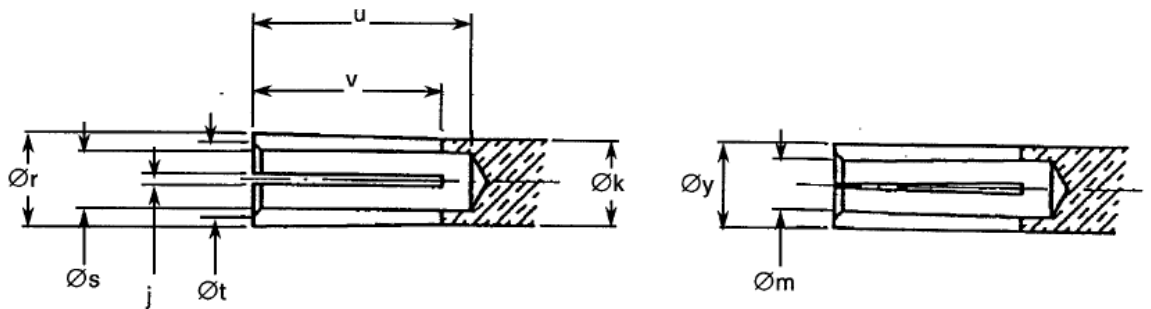

**FIGURE 3 – STANDARD TEST CONNECTOR INTERFACE – FEMALE CONTACT  
(CONTINUED)**

Symbol	Millimetres		Notes
	Min	Max	
a	5.21	5.28	Contact recess
b	5.08	5.28	Insert recess
c	0.51	1.02	Str. sect
ØD	9.60	9.68	
e	4.75	-	
f	8.36	8.46	
Øg	8.31	8.46	
Øh	6.99	7.01	
Øi	6.71	6.76	
j	0.26	0.34	4 slots /90° apart
Øk	2.16	2.18	
Øl	4.67	4.72	
Øm	1.21	1.3	After ht. treatment
n	1.73	2.24	
p	0	0.15	
Øq	-	6.5	
Ør	2.45	2.48	
Øs	1.52	1.58	
Øt	1.68	1.88	90°
u	5.21	-	
v	4.75 typical		
Øw	8.1	8.15	
Øy	2.23	2.31	Mated with Ø1.36 pin, gauge over slotted portion only
α	-	0.1	Radius

## 2 **APPLICABLE DOCUMENTS**

The following documents form part of this specification and shall be read in conjunction with it:

- (a) ESCC Generic Specification No. [3402](#) for RF Coaxial Connectors.
- (b) MIL-G-45204, Gold Plating, Electrodeposited.

## 3 **TERMS, DEFINITIONS, ABBREVIATIONS, SYMBOLS AND UNITS**

For the purpose of this specification, the terms, definitions, abbreviations, symbols and units specified in ESCC Basic Specification No. [21300](#) shall apply.

## 4 **REQUIREMENTS**

### 4.1 **GENERAL**

The complete requirements for procurement of the connectors specified herein are stated in this specification and ESCC Generic Specification No. [3402](#). Deviations from the Generic Specification applicable to this specification only, are listed in Para. 4.2.

Deviations from the applicable Generic Specification and this Detail Specification, formally agreed with specific Manufacturers on the basis that the alternative requirements are equivalent to the ESCC requirements and do not affect the components' reliability, are listed in the appendices attached to this specification.

### 4.2 **DEVIATIONS FROM GENERIC SPECIFICATION**

#### 4.2.1 **Deviations from Special In-process Controls**

None.

#### 4.2.2 **Deviations from Final Production Tests (Chart II)**

None.

#### 4.2.3 **Deviations from Burn-in Tests (Chart III)**

Chart III is not applicable.

#### 4.2.4 **Deviations from Qualification Tests (Chart IV)**

None.

#### 4.2.5 **Deviations from Lot Acceptance Tests (Chart V)**

None.

### 4.3 **MECHANICAL REQUIREMENTS**

#### 4.3.1 **Dimension Check**

The dimensions of the connectors specified herein shall be verified in accordance with the requirements set out in Para. 9.25 of ESCC Generic Specification No. [3402](#) and shall conform to those shown in Figures 2(a) and 2(b) of this specification.

#### 4.3.2 **Weight**

The maximum weight of the connectors specified herein shall be as specified in Figure 2(b).



#### 4.3.3 Coupling Proof Torque

The requirements for testing of the coupling proof torque are specified in Section 9 of ESCC Generic Specification No. 3402. The applied torque shall be 339N.cm.

#### 4.3.4 Cable Retention Force

The requirements for testing of the cable retention force are specified in Section 9 of ESCC Generic Specification No. 3402. Figure 2(b) specifies the values for axial loads. Torque shall be applied as follows.

##### 4.3.4.1 *Flexible Cables*

Flexible cables shall be rotated 180° in both directions.

Rotational movement shall be applied at 15cm from the connector.

##### 4.3.4.2 *Semi-rigid Cables*

The torque value shall be as follows:

RG 405/U : 11.28N.cm.

RG 402/U : 38.85N.cm.

RG 401/U : 38.85N.cm.

#### 4.3.5 Mating and Unmating Forces

The applicable measurement requirements are specified in Section 9 of ESCC Generic Specification No. 3402. The maximum torque during mating and unmating shall not exceed 22.6N.cm.

Whenever a test is performed on mated pairs of connectors, the pairs shall be torqued at 265N.cm.

#### 4.3.6 Endurance

The applicable test requirements are specified in Section 9 of ESCC Generic Specification No. 3402. The test conditions shall be as follows:

(a) Number of cycles: 500 for qualification; 100 for lot acceptance.

(b) Rate: 12 cycles maximum/minute.

#### 4.3.7 Residual Magnetism

Residual magnetism is not applicable to stainless steel connectors.

4.3.8 Contact Engagement and Separation Forces

The requirements for these measurements are specified in Section 9 of ESCC Generic Specification No. 3402 and apply to female contacts only.

(a) Oversize Pin

Steel test pin diameter : 1.384/1.388 mm.

Engagement depth : 2/2.5 mm.

Number of engagements : 3.

(b) Engagement Force Test (Maximum Diameter Test Pin)

Steel test pin diameter : 1.372/1.376 mm.

Engagement depth : 3/3.5 mm.

Engagement force : 9N max.

(c) Separation Force Test (Minimum Diameter Test Pin)

Steel test pin diameter : 1.308/1.321 mm.

Separation depth : 3/3.5 mm.

Separation force : 0.56N min.

**FIGURE 4 - TEST PIN CONFIGURATION**

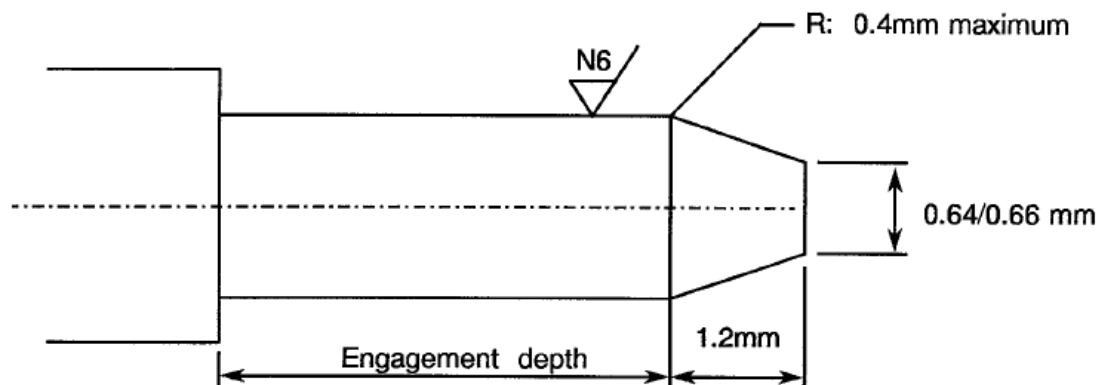

4.3.9 Contact Retention

The requirements for this test are specified in Section 9 of ESCC Generic Specification No. 3402. The test conditions are given in Figure 2(b). After testing, the connector interface dimensions shall be within the limits of Figure 2(a).

4.4 MATERIALS AND FINISHES

The materials and finishes shall be as specified herein. Where a definite material is not specified, a material which will enable the connectors specified herein to meet the performance requirements of this specification shall be used. Acceptance or approval of any constituent material does not guarantee acceptance of the finished product.

4.4.1 Shell, Coupling Nut

Material : Amagnetic stainless steel, electro-passivated.

For solder-type connectors: rear part of shell shall be protected by an adequate coating for solderability.

#### 4.4.2 Centre Contact

- Material : Copper alloy.  
Underplate : Nickel, 2µm minimum.  
Plating : Gold, 1.27µm minimum, Type 2 Grade C of MIL-G-45204.

#### 4.4.3 Inserts

- Material : PTFE and polyetherimid resin.  
Baking conditions : 10 cycles (-10, +55 °C). 1 cycle = 15 minutes minimum at each temperature with 5 minutes maximum transfer time.

#### 4.4.4 Gaskets

- Material : Silicone and fluoro-silicone.

#### 4.4.5 Accessories

Crimping and soldering elements:

- Material : Brass and amagnetic stainless steel.  
Underplate : Nickel, 2µm minimum.  
Adequate coating for good Solderability.

Nut:

- Material : Amagnetic stainless steel, electro-passivated.

Washers and clip:

- Material : Copper alloy.  
Plating : Nickel, 2µm minimum.

### 4.5 MARKING

#### 4.5.1 General

The marking of all components delivered to this specification shall be in accordance with the requirements of ESCC Basic Specification No. 21700 and the following paragraphs. Each component shall be marked in respect of:

- (a) The ESCC Component Number.
- (b) Characteristics.
- (c) Traceability Information.

#### 4.5.2 The ESCC Component Number

Each component shall bear the ESCC Component Number which shall be constituted and marked as follows:

Example: 340200801B

- Detail Specification Number: 3402008
- Type Variant (see Table 1(a)): 01
- Testing Level (B or C, as applicable): B

4.5.3 Characteristics

Characteristics cover the type of plating/material and 2 different dimensional aspects:

- (a) Variants of fixed configuration.
- (b) Variants where the rear end (length of contact A and length of insert B) may vary within a range limited by a specified maximum value.

4.5.3.1 *Variants of Fixed Configuration*

Each component shall be marked in respect of:

- (a) Type of plating/material.
- (b) Number.

The information shall be constituted and marked as follows:

Example: 301

- Type of plating/material (see Para. 4.5.3.3): 3
- Number (shall always be 01): 01

4.5.3.2 *Variants where Dimensions A and B of Figure 2(b) are indicated by a Maximum Only*

Each component shall be marked in respect of:

- (a) Type of plating/material.
- (b) Length and tolerance of centre contact (dimension A).
- (c) Length and tolerance of insert (dimension B).

The information shall be constituted and marked as follows:

Example: 313D0A02D5C

- Type of plating/material (see Para. 4.5.3.3): 3
- Contact length A: 13mm (see Para. 4.5.3.4): 13D0
- Tolerance on A:  $\pm 0.05\text{mm}$  (see Para. 4.5.3.5): A
- Insert length B: 2.5mm (see Para. 4.5.3.4): 02D5
- Tolerance on B:  $\pm 0.25\text{mm}$  (see Para. 4.5.3.5): C

**NOTES:**

1. Dimension A shall always be greater than B. Both values shall always be positive.
2. When dimension B (insert) is flush with the flange ( $B = 0$ ), the insert length shall be marked 00D0 with the appropriate tolerance.
3. When applicable, Figure 2(b) makes reference to Para. 4.5.3.

4.5.3.3 *Type of Plating/Material*

The type of plating/material shall be identified by means of the following code:

Code	Type of Plating/Material	Para.
3	Amagnetic stainless steel	4.4.1

4.5.3.4 *Length Values*

Length values shall be expressed by means of the following codes. The unit quantity for marking shall be millimetres.

Length Value	Code
XX.X	XXDX

4.5.3.5 *Tolerance*

The tolerance on length values shall be indicated by the letter codes specified hereafter:

Tolerance (mm)	Code Letter
±0.05	A
±0.1	B
±0.25	C

4.5.4 Traceability Information

Each component shall be marked in respect of traceability information in accordance with the requirements of ESCC Basic Specification No. [21700](#).

4.5.5 Marking of Small Components

When it is considered that the component is too small to accommodate the marking as specified above, as much as space permits shall be marked. The order of precedence shall be as specified in Para. 4.5.1. The marking information in full shall accompany each component in its primary package.

4.6 ELECTRICAL MEASUREMENTS

4.6.1 Electrical Measurements at Room Temperature

The parameters to be measured in respect of electrical characteristics are scheduled in Table 2. Unless otherwise specified, the measurements shall be performed at  $T_{amb} = +22 \pm 3 \text{ }^\circ\text{C}$ .

4.6.2 Electrical Measurements at High and Low Temperatures (Table 3)

Not applicable.

4.6.3 Circuits for Electrical Measurements

Not applicable.

4.7 BURN-IN TESTS (TABLES 4 AND 5)

Not applicable.

**TABLE 2 - ELECTRICAL MEASUREMENTS AT ROOM TEMPERATURE**

No.	Characteristics	Symbol	Spec. and/or test Method	Test Conditions	Limits		Unit
					Min.	Max.	
1	Insulation Resistance	R <sub>i</sub>	ESCC <a href="#">3402</a> , Para. 9.1	500 Vdc	5000	-	MΩ
2	Voltage Proof Leakage Current	I <sub>L</sub>	ESCC <a href="#">3402</a> , Para. 9.2	See Figure 2(b)	-	2	mA

**TABLES 3, 4 AND 5**

Not applicable.

4.8 ENVIRONMENTAL AND ENDURANCE TESTS4.8.1 Measurements and Inspections on Completion of Environmental Tests

The parameters to be measured on completion of environmental tests are scheduled in Table 6 of this specification. Unless otherwise stated, the measurements shall be performed at  $T_{amb} = +22 \pm 3$  °C.

4.8.2 Measurements and Inspections at Intermediate Points during Endurance Tests

Not applicable.

4.8.3 Measurements and Inspections on Completion of Endurance Tests

The parameters to be measured on completion of endurance tests are scheduled in Table 6 of this specification. Unless otherwise stated, the measurements shall be performed at  $T_{amb} = +22 \pm 3$  °C.

4.8.4 Conditions for Operating Life Tests (Part of Endurance Testing)

Not applicable.

4.8.5 Electrical Circuits for Operating Life Tests

Not applicable.

4.8.6 Conditions for High Temperature Storage Test (Part of Endurance Testing)

The requirements for the high temperature storage test are specified in Section 9 of ESCC Generic Specification No. [3402](#). The conditions for high temperature storage shall be the maximum operating temperature as specified in Figure 2(b).

**TABLE 6 - MEASUREMENTS AND INSPECTIONS ON COMPLETION OF ENVIRONMENTAL AND ENDURANCE TESTS**

No.	ESCC Generic Spec. No. 3402		Measurements and Inspections		Symbol	Limits		Units
	Environmental and Endurance Tests (1)	Test Method and Conditions	Identification	Conditions		Min.	Max.	
01	Contact Resistance	Para. 9.9	Contact Resistance	Centre Contact (20mV 10mA)	-	-	1.5	mΩ
				Shell (20mV 10mA)	-	-	0.7	mΩ
02	Vibration	Para 9.10	Full Engagement					
			Contact Resistance	Centre Contact (20mV 10mA)	-	-	1.5	mΩ
			Visual Examination	-	-	-	-	-
03	Shock or Bump	Para. 9.11	Full Engagement					
			Contact Resistance	Centre Contact (20mV 10mA)	-	-	1.5	mΩ
			Visual Examination	-	-	-	-	-
04	Rapid Change of Temperature	Para. 9.12	Contact Resistance	Centre Contact (20mV 10mA)	-	-	1.5	mΩ
			Voltage Proof	Figure 2(b)	I <sub>L</sub>	Table 2 Item 2		
			Visual Examination	-	-	-	-	-
05	Climatic Sequence	Para. 9.13	Low Air Pressure	0.1X value Figure 2(b)		No Breakdown or flashover		
			Voltage Proof After Damp Heat (within 1 to 24hrs)					
			Insulation Resistance (after 24 hrs)	Table 2 item 1	R <sub>i</sub>	200	-	MΩ
			Voltage Proof	Figure 2(b)	I <sub>L</sub>	Table 2 Item 2		
			External Visual Inspection	ESCC 3402 Para. 9.8	-	-	-	-
06	Cable Retention Force	Para. 9.14 and Para. 4.3.4 of this spec.	Continuity	-	-	-	-	-
07	Coupling Proof Torque	Para. 9.4	Interface Dimensions	-	-	Figure 2(a)		-
			Visual Examination	-	-	-	-	-
08	Mating/Unmating Forces	Para. 9.5	Torque	Para. 4.3.5	T <sub>qe</sub>	-	22.6	N.cm
09	Seal Test	Para. 9.7	Leakage	As applicable	-	No Bubbles		-
			External Visual Inspection	ESCC 3402 Para. 9.8	-	-	-	-
10	Cabling and Crimping Capability	Para. 9.15	Visual Examination	ESCC 3402 Para. 9.15	-	-	-	-
			Dimensions	ESCC 3402 Para. 9.15	-	Fig. 2(a) & 2(b)		
			Insulation Resistance	Table 2 Item 1	R <sub>i</sub>	5000	-	MΩ
			Voltage Proof	Figure 2(b)	I <sub>L</sub>	Table 2 item 2		
11	VSWR or Reflection Coefficient	Para. 9.16	VSWR	ESCC 3402 Para. 9.16	-	Figure 2(b)		-
12	Corona Level	Para. 9.17	Corona	ESCC 3402 Para. 9.17	-	Figure 2(b)		-

No.	ESCC Generic Spec. No. 3402		Measurements and Inspections		Symbol	Limits		Units
	Environmental and Endurance Tests (1)	Test Method and Conditions	Identification	Conditions		Min.	Max.	
13	Endurance	Para 9.18 and Para. 4.3.6 of this spec.	Mating/Unmating Forces	Para. 4.3.5	-	-	22.6	N.cm
			Contact Resist. Drift	Centre Contact (20mV 10mA)	-	-	2	mΩ
				Shell (20mV 10mA)	-	-	2	mΩ
			Visual Examination	-	-	-	-	-
14	RF Insertion Loss	Para. 9.19	Insertion Loss	ESCC 3402 Para. 9.19	-	Figure 2(b)		-
15	Corrosion	Para. 9.20	Visual Examination	-	No exposure of base metal			-
16	Residual Magnetism	Para. 9.21	Magnetism	-	-	Para. 4.3.7		-
17	Soldering Proof	Para. 9.22	Interface Dimensions	-	-	Figure 2(b)		-
			Mating/Unmating Forces	Para. 4.3.5	-	-	22.6	N.cm
			Insulation Resistance	Table 2 Item 1	R <sub>i</sub>	5000	-	MΩ
			Voltage Proof	Figure 2(b)	I <sub>L</sub>	-	-	-
			Contact Resistance	Centre Contact (20mV 10mA)	-	-	1.5	mΩ
				Shell (20mV 10mA)	-	-	0.7	mΩ
18	RF Leakage	Para. 9.23	Leakage	-	-	Figure 2(b)		-
19	High Temperature Storage	Para. 9.24 and Para. 4.8.6 of this spec.	Mating/Unmating Forces	Para. 4.3.5	-	-	22.6	N.cm
			Insulation Resistance	Table 2 Item 1	R <sub>i</sub>	5000	-	MΩ
			Voltage Proof	Figure 2(b)	I <sub>L</sub>	Table 2 item 2		-
			Contact Retention	Para. 4.3.9	-	Para. 4.3.9		-
			Visual Examination	-	-	-	-	-
			Contact Resistance	Centre Contact (20mV 10mA)	-	-	3	mΩ
	Shell (20mV 10mA)	-	-	3	mΩ			
	External Visual Inspection	ESCC 3402 Para. 9.8	-	-	-	-	-	
20	External Visual Inspection	Para. 9.8			-	-	-	-
21	Permanence of Marking	Para. 9.27			-	-	-	-

**NOTES:**

1. The tests in this Table refer to either Chart IV or V and shall be used as applicable.



**FIGURE 2(b) – VARIANTS**

**VARIANT 01 - STRAIGHT PLUG, SOLDER TYPE, FOR SEMI-RIGID CABLE Ø3.58mm**

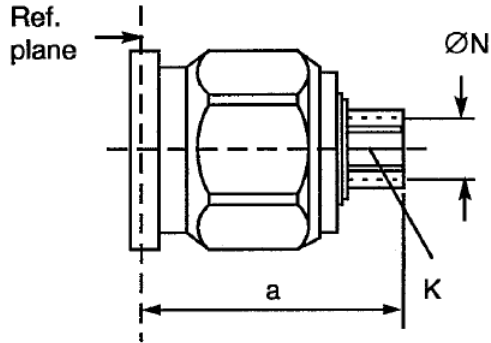

Symbol	Millimetres		Notes
	Min.	Max.	
a	19.2	19.98	
ØN	3.65	3.7	
K	-	5	Hexagon

ELECTRICAL CHARACTERISTICS	VALUES	UNITS
Continuous max. power at 17.6 GHz at +22°C	75	W
Frequency range	0 to 18	GHz
Maximum voltage standing wave ratio (VSWR)	1.1 + 0.005 f (GHz) up to 12.4 GHz 1.16 + 0.008 f (GHz) up to 18 GHz	
Maximum insertion loss	0.06 √f (GHz)	dB
RF leakage	-115 + 20 log f (GHz)	dB
Voltage proof	1500	Vrms
Corona level	375	Vrms

MECHANICAL CHARACTERISTICS	VALUES	UNITS
Mini centre contact retention force (axial)	Not applicable	N
Mini centre contact retention torque	Not applicable	N.cm
Mini cable retention force	272	N
Mini cable retention torque value	40	N.cm
Maximum weight	14	g

OTHER CHARACTERISTICS	VALUES	UNITS
Rapid change of temperature - peak value	+115	°C
Operating temperature range	-65 to +105	°C
Maxi leakage (panel sealed connectors)	Not applicable	
Maxi leakage (hermetic sealed connector)	Not applicable	
Solderability	Applicable	
Soldering proof	Applicable	
Cables used	KS 2, RG 402	

**FIGURE 2(b) – VARIANTS (CONTINUED)**

**VARIANT 02 - STRAIGHT PLUG, SOLDER TYPE, FOR SEMI-RIGID CABLE Ø6.35mm**

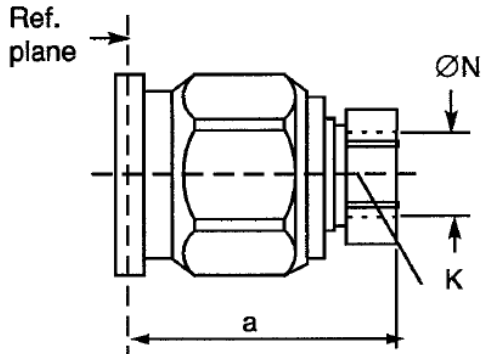

Symbol	Millimetres		Notes
	Min.	Max.	
a	19.2	20	
ØN	6.45	6.5	
K	-	8	Hexagon

ELECTRICAL CHARACTERISTICS	VALUES	UNITS
Continuous max. power at 17.6 GHz at +22°C	90	W
Frequency range	0 to 18	GHz
Maximum voltage standing wave ratio (VSWR)	1.1 + 0.005 f (GHz) up to 12.4 GHz 1.16 + 0.008 f (GHz) up to 18 GHz	
Maximum insertion loss	0.06 √f (GHz)	dB
RF leakage	-115 + 20 log f (GHz)	dB
Voltage proof	1500	Vrms
Corona level	500	Vrms

MECHANICAL CHARACTERISTICS	VALUES	UNITS
Mini centre contact retention force (axial)	Not applicable	N
Mini centre contact retention torque	Not applicable	N.cm
Mini cable retention force	408	N
Mini cable retention torque value	50	N.cm
Maximum weight	16	g

OTHER CHARACTERISTICS	VALUES	UNITS
Rapid change of temperature - peak value	+90	°C
Operating temperature range	-65 to +90	°C
Maxi leakage (panel sealed connectors)	Not applicable	
Maxi leakage (hermetic sealed connector)	Not applicable	
Solderability	Applicable	
Soldering proof	Applicable	
Cables used	RG401 / KS3	

**FIGURE 2(b) – VARIANTS (CONTINUED)**

**VARIANT 03 - STRAIGHT PLUG, SOLDER TYPE, FOR CABLE SHF5**

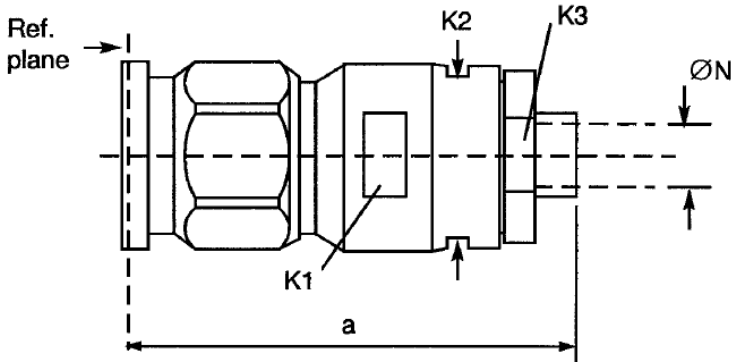

Symbol	Millimetres		Notes
	Min.	Max.	
a	40.75	41.55	
ØN	5.3	5.35	
K1	-	13	2 flats
K2	-	13	2 flats
K3	-	12	2 flats

ELECTRICAL CHARACTERISTICS	VALUES	UNITS
Continuous max. power at 17.6 GHz at +22°C	90	W
Frequency range	0 to 18	GHz
Maximum voltage standing wave ratio (VSWR)	1.3	
Maximum insertion loss	0.06 √f (GHz)	dB
RF leakage	-90 + 20 log f (GHz)	dB
Voltage proof	1000	Vrms
Corona level	250	Vrms

MECHANICAL CHARACTERISTICS	VALUES	UNITS
Mini centre contact retention force (axial)	27.2	N
Mini centre contact retention torque	Not applicable	N.cm
Mini cable retention force	40	N
Mini cable retention torque value	Not applicable	N.cm
Maximum weight	35	g

OTHER CHARACTERISTICS	VALUES	UNITS
Rapid change of temperature - peak value	+165	°C
Operating temperature range	-65 to +165	°C
Maxi leakage (panel sealed connectors)	Not applicable	
Maxi leakage (hermetic sealed connector)	Not applicable	
Solderability	Applicable	
Soldering proof	Applicable	
Cables used	F1703.245	

**FIGURE 2(b) – VARIANTS (CONTINUED)**

**VARIANT 04 - STRAIGHT PLUG, SOLDER TYPE, FOR CABLE SHF8**

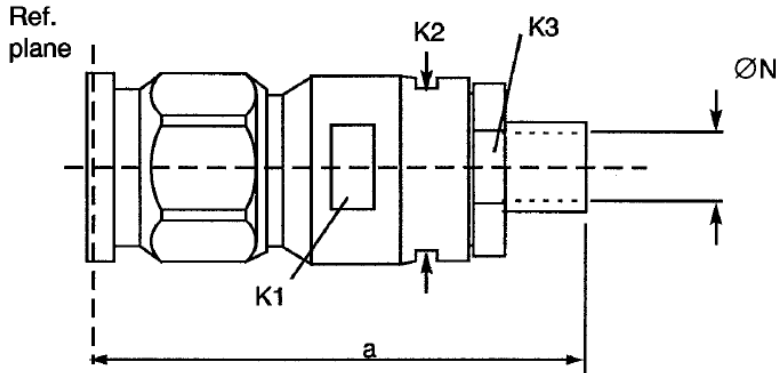

Symbol	Millimetres		Notes
	Min.	Max.	
a	52.75	54.35	
ØN	8.3	8.35	
K1	-	13	2 flats
K2	-	13	2 flats
K3	-	12	2 flats

ELECTRICAL CHARACTERISTICS	VALUES	UNITS
Continuous max. power at 17.6 GHz at +22°C	120	W
Frequency range	0 to 18	GHz
Maximum voltage standing wave ratio (VSWR)	1.3	
Maximum insertion loss	0.06 √f (GHz)	dB
RF leakage	-90 + 20 log f (GHz)	dB
Voltage proof	1000	Vrms
Corona level	250	Vrms

MECHANICAL CHARACTERISTICS	VALUES	UNITS
Mini centre contact retention force (axial)	27.2	N
Mini centre contact retention torque	Not applicable	N.cm
Mini cable retention force	50	N
Mini cable retention torque value	Not applicable	N.cm
Maximum weight	36	g

OTHER CHARACTERISTICS	VALUES	UNITS
Rapid change of temperature - peak value	+165	°C
Operating temperature range	-65 to +165	°C
Maxi leakage (panel sealed connectors)	Not applicable	
Maxi leakage (hermetic sealed connector)	Not applicable	
Solderability	Applicable	
Soldering proof	Applicable	
Cables used	F1703.248	

**FIGURE 2(b) – VARIANTS (CONTINUED)**

**VARIANT 05 - ELBOW, SOLDER TYPE, FOR CABLE SHF5**

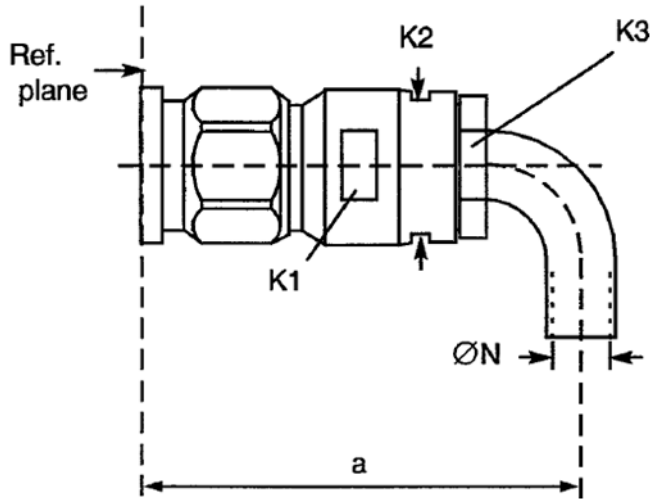

Symbol	Millimetres		Notes
	Min.	Max.	
a	42.85	44.45	
ØN	5.3	5.35	
K1	-	13	2 flats
K2	-	13	2 flats
K3	-	12	2 flats

ELECTRICAL CHARACTERISTICS	VALUES	UNITS
Continuous max. power at 17.6 GHz at +22°C	90	W
Frequency range	0 to 18	GHz
Maximum voltage standing wave ratio (VSWR)	1.3	
Maximum insertion loss	0.06 √f (GHz)	dB
RF leakage	-90 + 20 log f (GHz)	dB
Voltage proof	1000	Vrms
Corona level	250	Vrms

MECHANICAL CHARACTERISTICS	VALUES	UNITS
Mini centre contact retention force (axial)	27.2	N
Mini centre contact retention torque	Not applicable	N.cm
Mini cable retention force	40	N
Mini cable retention torque value	Not applicable	N.cm
Maximum weight	37	g

OTHER CHARACTERISTICS	VALUES	UNITS
Rapid change of temperature - peak value	+165	°C
Operating temperature range	-65 to +165	°C
Maxi leakage (panel sealed connectors)	Not applicable	
Maxi leakage (hermetic sealed connector)	Not applicable	
Solderability	Applicable	
Soldering proof	Applicable	
Cables used	F1703.245	

**FIGURE 2(b) – VARIANTS (CONTINUED)**

**VARIANT 06 - ELBOW, SOLDER TYPE, FOR CABLE SHF8**

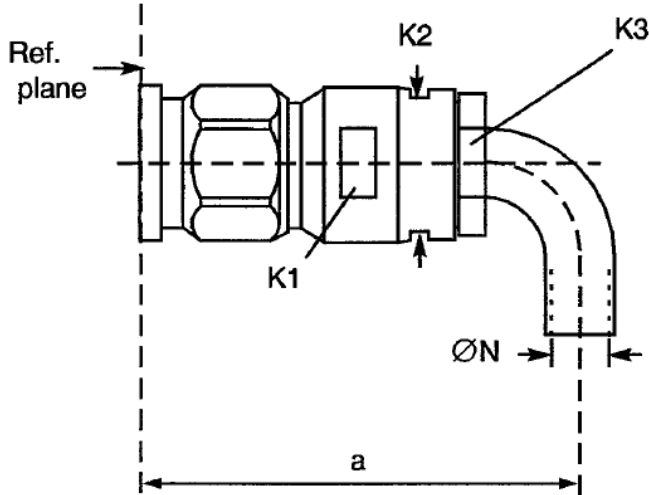

Symbol	Millimetres		Notes
	Min.	Max.	
a	48.65	49.65	
ØN	8.3	8.35	
K1	-	13	2 flats
K2	-	13	2 flats
K3	-	12	2 flats

ELECTRICAL CHARACTERISTICS	VALUES	UNITS
Continuous max. power at 17.6 GHz at +22°C	120	W
Frequency range	0 to 18	GHz
Maximum voltage standing wave ratio (VSWR)	1.3	
Maximum insertion loss	0.06 √f (GHz)	dB
RF leakage	-90 + 20 log f (GHz)	dB
Voltage proof	1000	Vrms
Corona level	250	Vrms

MECHANICAL CHARACTERISTICS	VALUES	UNITS
Mini centre contact retention force (axial)	27.2	N
Mini centre contact retention torque	Not applicable	N.cm
Mini cable retention force	50	N
Mini cable retention torque value	Not applicable	N.cm
Maximum weight	38	g

OTHER CHARACTERISTICS	VALUES	UNITS
Rapid change of temperature - peak value	+165	°C
Operating temperature range	-65 to +165	°C
Maxi leakage (panel sealed connectors)	Not applicable	
Maxi leakage (hermetic sealed connector)	Not applicable	
Solderability	Applicable	
Soldering proof	Applicable	
Cables used	F1703.248	

**FIGURE 2(b) – VARIANTS (CONTINUED)**

**VARIANT 07 – SQUARE FLANGE RECEPTACLE**

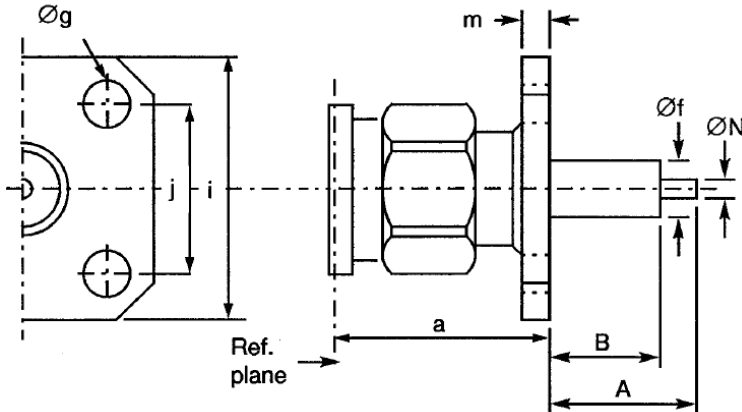

Symbol	Millimetres		Notes
	Min.	Max.	
a	20.99	21.57	
A	-	40	Note 1
B	-	20	Note 1
Øf	5.15	5.3	
Øg	3.1	3.3	4 holes
i	18.9	19.1	
j	13.45	13.55	
m	1.9	2.1	
ØN	1.59	1.69	

**NOTES**

- To specify dimensions, see Para. 4.5.3.

ELECTRICAL CHARACTERISTICS	VALUES	UNITS
Continuous max. power at 17.6 GHz at +22°C	100	W
Frequency range	0 to 18	GHz
Maximum voltage standing wave ratio (VSWR)	$1.1 + 0.01 f$ (GHz)	dB
Maximum insertion loss	$0.06 \sqrt{f}$ (GHz)	dB
RF leakage	$-80 + 20 \log f$ (GHz)	dB
Voltage proof	1500	V <sub>rms</sub>
Corona level	Not applicable	V <sub>rms</sub>

MECHANICAL CHARACTERISTICS	VALUES	UNITS
Mini centre contact retention force (axial)	27.2	N
Mini centre contact retention torque	2.8	N.cm
Mini cable retention force	Not applicable	N
Mini cable retention torque value	Not applicable	N.cm
Maximum weight	25	g

OTHER CHARACTERISTICS	VALUES	UNITS
Rapid change of temperature - peak value	+115	°C
Operating temperature range	-65 to +105	°C
Maxi leakage (panel sealed connectors)	Not applicable	
Maxi leakage (hermetic sealed connector)	Not applicable	
Solderability	Applicable	
Soldering proof	Applicable	
Cables used	Not applicable	