



**OPTICAL FIBRE CABLE ASSEMBLIES
WITH SINGLE FIBRE FERRULES**

BASED ON TYPES MINI AVIM, MIDI AVIM

ESCC Detail Specification No. 3420/001

Issue 3	May 2019
---------	----------



LEGAL DISCLAIMER AND COPYRIGHT

European Space Agency, Copyright © 2019, All rights reserved.

The European Space Agency disclaims any liability or responsibility, to any person or entity, with respect to any loss or damage caused, or alleged to be caused, directly or indirectly by the use and application of this ESCC publication.

This publication, without the prior permission of the European Space Agency and provided that it is not used for a commercial purpose, may be:

- copied in whole, in any medium, without alteration or modification.
- copied in part, in any medium, provided that the ESCC document identification, comprising the ESCC symbol, document number and document issue, is removed.

DOCUMENTATION CHANGE NOTICE

(Refer to <https://escies.org> for ESCC DCR content)

DCR No.	CHANGE DESCRIPTION
1256	Specification upissued to incorporate changes per DCR

TABLE OF CONTENTS

1	GENERAL	6
1.1	SCOPE	6
1.2	APPLICABLE DOCUMENTS	6
1.3	TERMS, DEFINITIONS, ABBREVIATIONS, SYMBOLS AND UNITS	6
1.4	THE ESCC COMPONENT NUMBER AND COMPONENT TYPE VARIANTS	6
1.4.1	The ESCC Component Number	6
1.4.1.1	Characteristics Codes	7
1.4.2	Component Type Variants and Range of Components	10
1.5	MAXIMUM RATINGS	11
1.6	HANDLING PRECAUTIONS	11
1.7	PHYSICAL DIMENSIONS	12
1.7.1	Optical Fibre Cable Assembly (All Configurations) – Variants 01, 04, 05, 06	12
1.7.2	Mating Adapter with Square Flange for Connectors: M to M, D to D, M to D – Variant 02	13
1.7.3	Hybrid Mating Adapter for Connectors: M to A, D to A – Variant 03	14
1.7.4	Optical Connectors	15
1.7.4.1	Optical Connector: Type Code M (Mini AVIM)	15
1.7.4.2	Optical Connector: Type Code D (Midi AVIM)	16
1.7.4.3	Optical Connector: Type Code A (AVIM)	17
1.7.4.4	Optical Connector: Type Code U (Micro AVIM)	17
1.7.4.5	Optical Connector: Type Codes F and L (Ferrule 2.5 x 10.5mm and Ferrule 2.5 x 17.5mm)	17
1.7.5	Optical Interface and Polishing	18
1.7.5.1	Polishing Type Codes: PC 0° and Flat 0°	19
1.7.5.2	Polishing Type Codes: APC 4°, APC 8° and Flat 8°	20
1.7.6	Optical Fibre	21
1.7.6.1	Optical Fibre Type Code 01: Optical Functions: PM and PM-PS	21
1.7.6.2	Optical Fibre Type Codes 02 and 03: Optical Functions: SM and PS	23
1.7.7	Cable	24
1.8	MATERIALS AND FINISHES	24
2	REQUIREMENTS	25
2.1	GENERAL	25
2.1.1	Deviations from the Generic Specification	25
2.1.1.1	Deviations from Screening Tests – Chart F3	25
2.1.1.2	Deviations from Qualification and Periodic Testing – Chart F4	25
2.2	MARKING	25
2.3	ROOM TEMPERATURE OPTICAL AND GEOMETRICAL MEASUREMENTS	26
2.3.1	Geometrical Measurements (Variants 01, 04, 05, 06)	26



2.3.2	Optical Measurements (Variants 01, 04, 05, 06)	26
2.4	PARAMETER DRIFT VALUES	28
2.5	INTERMEDIATE AND END-POINT OPTICAL AND GEOMETRICAL MEASUREMENTS	28
APPENDIX A		33

1 GENERAL

1.1 SCOPE

This specification details the ratings, physical and electrical characteristics and test and inspection data for the component type variants and/or the range of components specified below. It supplements the requirements of, and shall be read in conjunction with, the ESCC Generic Specification listed under Applicable Documents.

1.2 APPLICABLE DOCUMENTS

The following documents form part of this specification and shall be read in conjunction with it:

- (a) ESCC Generic Specification No. [3420](#).

1.3 TERMS, DEFINITIONS, ABBREVIATIONS, SYMBOLS AND UNITS

For the purpose of this specification, the terms, definitions, abbreviations, symbols and units specified in ESCC Basic Specification No. [21300](#) shall apply.

1.4 THE ESCC COMPONENT NUMBER AND COMPONENT TYPE VARIANTS

1.4.1 The ESCC Component Number

The ESCC Component Number shall be constituted as follows:

Example (for Optical Fibre Cable Assemblies: Variants 01, 04, 05, 06):

342000104-01S-M0P-U4PH-6000-0100

- Detail Specification Reference: 3420001
- Component Type Variant Number: 04 (as required)
- Characteristic Code: Optical Fibre Type (SM.15-P-8/125-UV/UV-400): 01 (as required)
- Characteristic Code: Cable Type (Section of PEEK Loose Tube): S (as required)
- Characteristic Code: Connector A Type (Mini AVIM): M (as required)
- Characteristic Code: Connector A Polishing Type (PC 0°): 0 (as required)
- Characteristic Code: Connector A Optical Function (PM): P (as required)
- Characteristic Code: Connector B Type (Micro AVIM): U (as required)
- Characteristic Code: Connector B Polishing Type (APC 4°): 4 (as required)
- Characteristic Code: Connector B Optical Function (PM-PS): PH (as required)
- Characteristic Code: Total Assembly Length (6000mm): 6000 (as required)
- Characteristic Code: Cable Type S Length (100mm): 0100 (as required; left blank if not applicable)

Example (for Mating Adapters: Variants 02, 03):

342000102

- Detail Specification Reference: 3420001
- Component Type Variant Number: 02 (as required)

1.4.1.1 Characteristics Codes

Characteristics to be codified as part of the ESCC Component Number shall be as follows:

(a) Optical Fibre Type and Optical Function

The optical fibre type and related optical function available for each connector (see Para. 1.7.6), at side A and/or side B (as applicable), of the optical fibre cable assembly shall be expressed by means of the following codes:

Optical Fibre Type	Optical Fibre Type Code	Optical Function	Optical Function Code
SM.15-P-8/125-UV/UV-400	01	PM (Single Mode Polarization Maintaining)	P
		PM-PS (Single Mode Polarization Maintaining, Power Solution Collimated)	PH
HI-1060-H	02	SM (Single Mode)	S
		PS (Single Mode, Power Solution Collimated)	H
SMF-28e+	03	SM (Single Mode)	S
		PS (Single Mode, Power Solution Collimated)	H

(b) Cable Type

The cable type (see Para. 1.7.7) of the optical fibre cable assembly shall be expressed by means of the following codes:

Cable Type	Code	Remarks
Not Applicable (i.e. Bare Fibre Only)	B	
PEEK Loose Tube	P	
Section of PEEK Loose Tube	S	See Para. 1.4.1.1(g) for length (see Para. 1.7.1 Dimension M)
Elastomeric Loose Tube	H	
Aramid Reinforced LSOH Coated Cable	C	

(c) Optical Connector A Type

The connector type (see Para. 1.7.4) at side A of the optical fibre cable assembly shall be expressed by means of the following codes:

Connector A Type	Code	Remarks
Mini AVIM	M	Only for use as Connector A in Variants 01, 04
Midi AVIM	D	Only for use as Connector A in Variants 05, 06

(d) Optical Connector B Type

The connector type (see Para. 1.7.4) at side B of the optical fibre cable assembly shall be expressed by means of the following codes:

Connector B Type	Code	Remarks
Mini AVIM	M	
Midi AVIM	D	
AVIM	A	
Micro AVIM	U	
Ferrule 2.5 x 10.5mm	F	
Ferrule 2.5 x 17.5mm	L	
No Connector	X	Pigtail

(e) Polishing Type (Connectors A and/or B)

The polishing type applicable to the ferrule and fibre end-face in each connector (see Para. 1.7.5) at side A and/or side B (as applicable), of the optical fibre cable assembly shall be expressed by means of the following codes:

Polishing Type	Code	Remarks
PC 0° (Physical Contact)	0	Used with optical function: SM, PM, PS, PM-PS
APC 8° (Angled Physical Contact)	8	Used with optical function: SM, PM
APC 4° (Angled Physical Contact)	4	Used with optical function: PS, PM-PS
Flat 0° (Flat free space)	F	Used with optical function: SM, PM, PS, PM-PS
Flat 8° (Angled Flat free space)	A	Used with optical function: SM, PM, PS, PM-PS
Not Applicable	X	Polishing type code to be used for the connector at side B when connector B type is: X (No Connector)

(f) Optical Fibre Cable Assembly Length

The total length, L, of the optical fibre cable assembly (see Para. 1.7.1) shall be expressed by means of the following codes:

Total Optical Fibre Cable Assembly Length L (mm)	Code
XXX (200 to 999)	0XXX
XXXX (1000 to 6000)	XXXX

- (g) Cable Type Code S Length
For cable type code S only, the length, M, of the section of PEEK loose tube (see Para. 1.7.1) shall be expressed by means of the following codes. For all other cable types, this characteristic code shall be blank.

Cable Type Code S (Section of PEEK Loose Tube) Length M (mm)	Code
XXX (60 to 99)	00XX
XXX (100 to 999)	0XXX
XXXX (1000 to 6000)	XXXX

1.4.2 Component Type Variants and Range of Components

The component type variants and range of components applicable to this specification are as follows:

Variant Number	Component Type	Connector A Type Code (Note 1)	Conn. A Optical Function (Notes 1, 2)	Optical Fibre Type Code (Note 1)	Cable Type Code (Note 1)	Connector B Type Code (Note 1)	Conn. B Optical Function (Notes 1, 2)	Weight Max (g)
01	Mini AVIM Optical Fibre Cable Assembly (All applicable configurations)	M	PM	01	B, P, S, H	M, D, A, U, F, L, X	PM	See Note 3
			SM	02, 03			SM	
02	Mating Adapter with Square Flange for Connectors: M to M, D to D, M to D	N/A	N/A	N/A	N/A	N/A	N/A	2.6
03	Hybrid Mating Adapter for Connectors: M to A, D to A	N/A	N/A	N/A	N/A	N/A	N/A	1.7
04	Mini AVIM Expanded Beam Optical Fibre Cable Assembly (All applicable configurations)	M	PM	01	B, P, S, H	M, D, A, U, F, L, X	PM-PS	See Note 3
			PM-PS	01			PM, PM-PS	
			SM	02, 03			PS	
			PS	02, 03			SM, PS	
05	Midi AVIM Optical Fibre Cable Assembly (All applicable configurations)	D	PM	01	B, P, S, H	M, D, A, U, F, L, X	PM	See Note 3
			SM	02, 03			SM	
06	Midi AVIM Optical Fibre Reinforced Cable Assembly (All applicable configurations)	D	PM	01	C	D, A	PM	See Note 3
			SM	02, 03			SM	

NOTES:

- See Para. 1.4.1.1 for details on the available optical connector types, optical functions, optical fibre types, and cable types.
- See Para. 1.4.1.1(e) for details on the available polishing types for each optical function.
- The total maximum weight of an optical fibre cable assembly is calculated from the individual maximum weights of the various piece parts, as applicable, as follows:

Piece Part Category	Code (See Para. 1.4.1.1)	Weight Max
Each Optical Connector	M	1.2g
	D	2.8g
	A	6.2g
	U	0.4g
	F	0.25g
	L	0.3g
Optical Fibre	All Types	0.2g/m
Cable	P, S	0.7g/m
	H	0.6g/m
	C	3g/m

1.5 MAXIMUM RATINGS

The maximum ratings shall not be exceeded at any time during use or storage.

Maximum ratings shall only be exceeded during testing to the extent specified in this specification and when stipulated in Test Methods and Procedures of the ESCC Generic Specification.

Characteristics	Symbols	Maximum Ratings	Units	Remarks
Operating Temperature Range Variants 01, 02, 03, 05: Variant 04: Variant 06:	T_{op}	-55 to +85 -25 to +70 -10 to +60	°C	T_{amb}
Storage Temperature Range Variants 01, 02, 03, 05: Variant 04: Variant 06:	T_{stg}	-55 to +85 -25 to +70 -10 to +60	°C	T_{amb}
Operating Wavelength Range • Optical Fibre Type Code: 01 • Optical Fibre Type Code: 02 • Optical Fibre Type Code: 03	λ	1540 to 1625 980 to 1625 1300 to 1625	nm	Note 1. For all cable assemblies using the specified optical fibre types.
Coupling Nut Torque	T_q	30	N.cm	

NOTES:

- Nominal operating wavelength shall be as follows:
 - For all cable assemblies with Optical Fibre Type Code 01: 1550nm
 - For all cable assemblies with Optical Fibre Type Code 02: 1060nm
 - For all cable assemblies with Optical Fibre Type Code 03: 1550nm

1.6 HANDLING PRECAUTIONS

These devices are susceptible to degradation due to contamination. Dust covers provided shall be used to protect the ferrule end-face when the connectors are in an unmated condition. Direct contact with the ferrule end-face during handling should be prevented.

In order to ensure correct function, each mating shall occur after a visual inspection and, if necessary, cleaning of the ferrule end-faces on both sides of a connection and the mating adapter.

In the event that contamination of the ferrule end-face has occurred, it can be cleaned using a suitable method which should be verified by a visual examination at x200 magnification.

1.7 PHYSICAL DIMENSIONS

1.7.1 Optical Fibre Cable Assembly (All Configurations) – Variants 01, 04, 05, 06

EXAMPLE: PATCHCORD (NOTE 1)

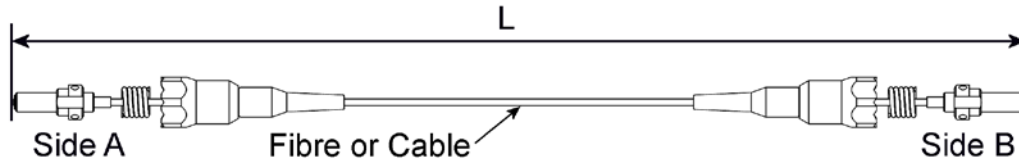

EXAMPLE: HYBRID PATCHCORD (NOTE 2)

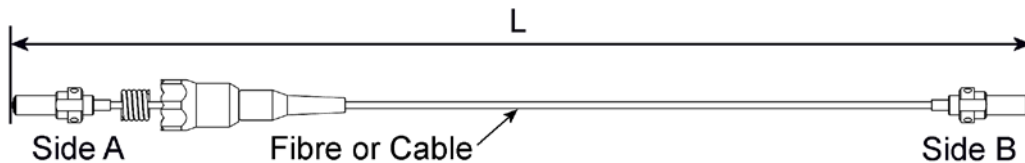

EXAMPLE: PIGTAIL (NOTE 3)

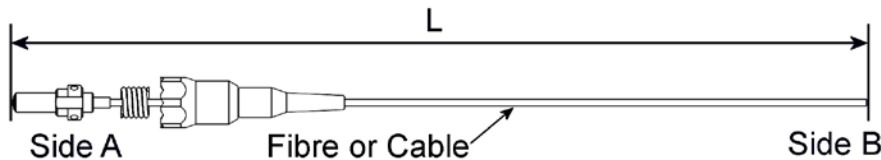

EXAMPLE: PIGTAIL (NOTE 3)

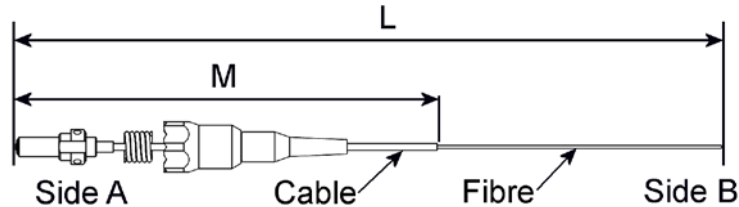

Symbols	Dimensions (mm)		Tolerance (mm)	Remarks
	Min	Max		
L	200	499	±50	As required. See Note 4.
	500	999	±100	
	1000	6000	±150	
M	60	L	±5	As required (Cable type code S only). Available on patchcords, hybrid patchcords and pigtails.

NOTES:

1. Patchcords have the same connector type on side A and B; see Para. 1.7.4 for connector details, as applicable.
2. Hybrid patchcords have a different connector type on side B to that on side A; see Para. 1.7.4 for connector details, as applicable.
3. Pigtails only have a connector on side A; see Para. 1.7.4 for connector details, as applicable.
4. The limits for Dimension L may be further limited depending on the selected optical fibre cable assembly configuration details. Any such further limitations will be advised by the Manufacturer during procurement.

1.7.2 Mating Adapter with Square Flange for Connectors: M to M, D to D, M to D – Variant 02

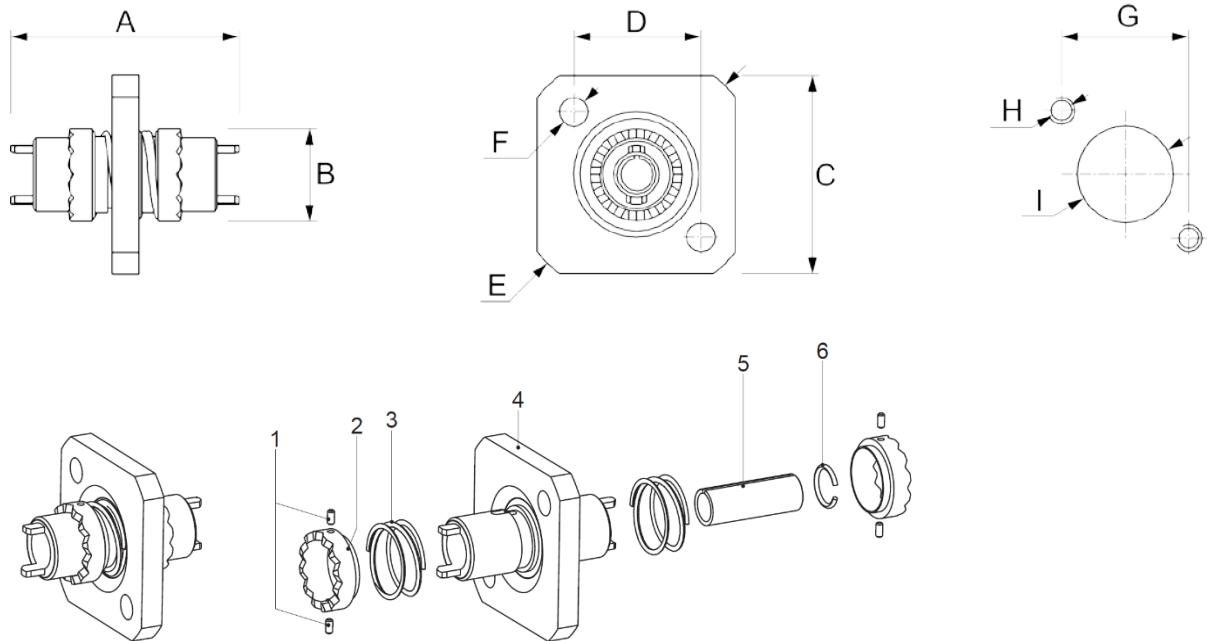

Symbols	Dimensions (mm)		Remarks
	Min	Max	
A	17.1	17.3	
ØB	6.8	7.2	
C	14.9	15.1	square
D	9.4	9.6	square
ØE	18.9	19.1	
ØF	2.2	2.4	
G	9.3	9.7	Cut out
ØH	M2.2		Cut out
ØI	7.3	7.7	Cut out

NOTES:

1. Exploded part item view key:

- 1: Pin (x4)
- 2: Anti-rotation ring
- 3: Anti-rotation spring (x2)
- 4: Main body & flange
- 5: Split sleeve
- 6: Locking washer

1.7.3 Hybrid Mating Adapter for Connectors: M to A, D to A – Variant 03

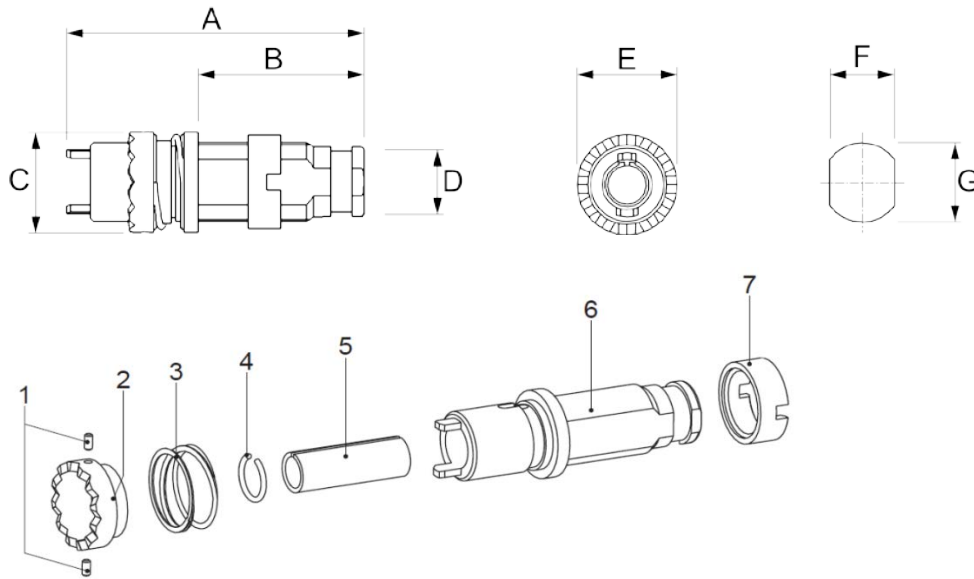

Symbols	Dimensions (mm)		Remarks
	Min	Max	
A	20.7	20.9	
B	11.4	11.6	
ØC	6.9	7.1	
D	4.2	4.3	
ØE	6.9	7.1	
F	4.3	4.7	Cut out
ØG	5.7	5.9	Cut out

NOTES:

1. Exploded part item view key:
 - 1: Pin (x2)
 - 2: Anti-rotation ring
 - 3: Anti-rotation spring
 - 4: Locking washer
 - 5: Split sleeve
 - 6: Main body
 - 7: Locking ring

1.7.4 Optical Connectors

1.7.4.1 *Optical Connector: Type Code M (Mini AVIM)*

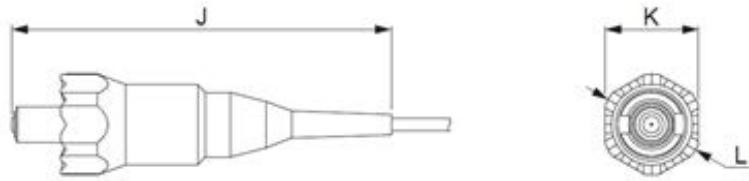

Exploded View

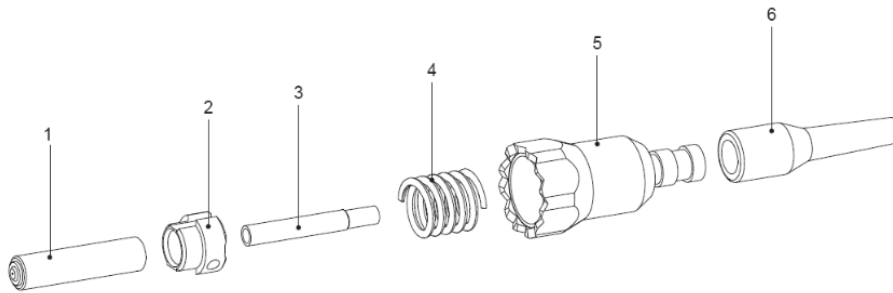

Ferrule Assembly Details

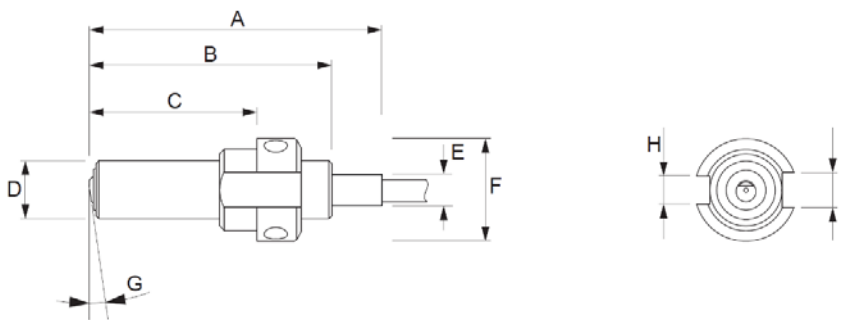

Symbols	Dimensions (mm)		Remarks
	Min	Max	
A	12.1	12.5	
B	10.45	10.6	
C	7.15	7.30	
ØD	2.5		Optical interface; see Para. 1.7.5
ØE	1.4	1.6	
ØF	4.35	4.45	
G	0°, 4° or 8°		Optical interface; see Para. 1.7.5
H	1.21	1.22	Mechanical key A
I	1.51	1.52	Mechanical key B
J	26	28	
K	6.45	6.5	Across flats
L	6.95	7.05	

NOTES:

1. Exploded part item view key:
 - 1: Ferrule
 - 2: Interface ring
 - 3: Ferrule back tube
 - 4: Spring
 - 5: Outside shell
 - 6: Anti-flexion boot

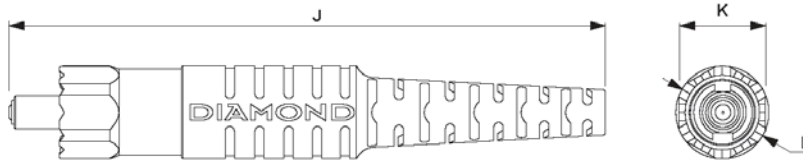
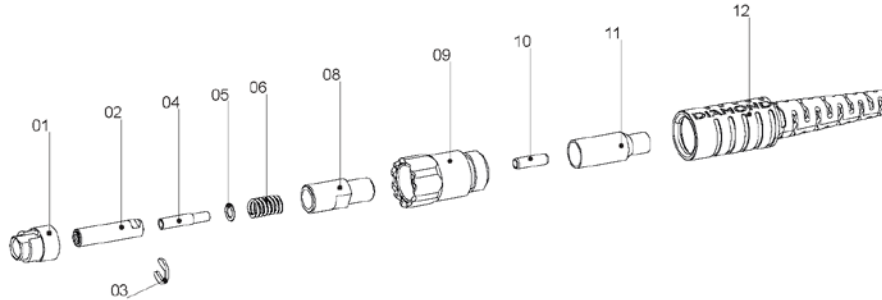
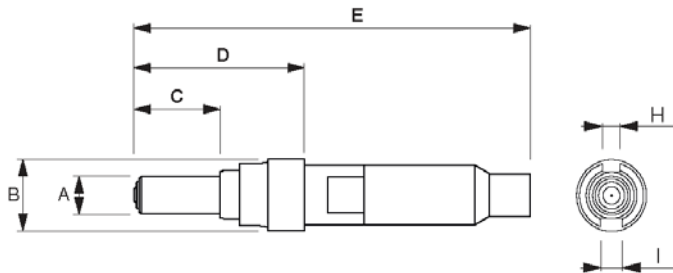
1.7.4.2 Optical Connector: Type Code D (Midi AVIM)

Exploded View

Ferrule Assembly Details

Symbols	Dimensions (mm)		Remarks
	Min	Max	
ØA	2.5		Optical interface; see Para. 1.7.5
ØB	4.7	4.9	
C	25.4	25.8	
D	11.7	11.9	
E	5.65	5.85	
G	0°, 4° or 8°		Optical interface; see Para. 1.7.5
H	1.21	1.22	Mechanical key A
I	1.51	1.52	Mechanical key B
J	43	47	
K	6.45	6.5	Across flats
L	6.95	7.05	

NOTES:

- Exploded part item view key:
 - 01: Anti-rotation nose ring
 - 02: Ferrule
 - 03: Clip
 - 04: Ferrule tube
 - 05: Anti-rotation washer
 - 06: Ferrule Spring
 - 08: Body
 - 09: Outside hexagonal shell
 - 10: Crimping bushing
 - 11: Crimp sleeve
 - 12: Anti-flexion boot

1.7.4.3 *Optical Connector: Type Code A (AVIM)*
See ESCC Detail Specification No. [3420/002](#).

1.7.4.4 *Optical Connector: Type Code U (Micro AVIM)*
See Para. 1.7.4.1, using same part items for Mini AVIM: 1 ferrule, 2 Interface ring and 3 ferrule back tube (Dimensions A to I inclusive).

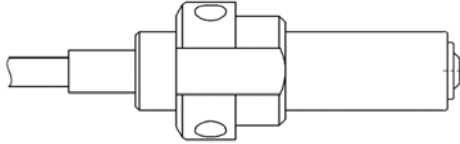

1.7.4.5 *Optical Connector: Type Codes F and L (Ferrule 2.5 x 10.5mm and Ferrule 2.5 x 17.5mm)*

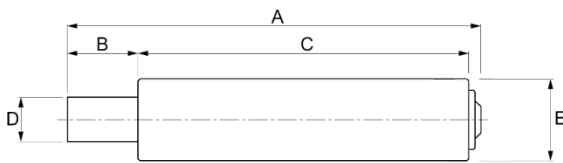

Symbols	Dimensions (mm)		Remarks
	Min	Max	
A	12.1	12.5	For type code F (Ferrule 2.5mm x 10.5mm)
	17.1	17.5	For type code L (Ferrule 2.5mm x 17.5mm)
B	1.5	2.1	
C	10.45	10.6	For type code F (Ferrule 2.5mm x 10.5mm)
	17.45	17.6	For type code L (Ferrule 2.5mm x 17.5mm)
ØD	1.4	1.6	
ØE	2.5		For optical interface see Para. 1.7.5

1.7.5 Optical Interface and Polishing

Ferrule End-Face

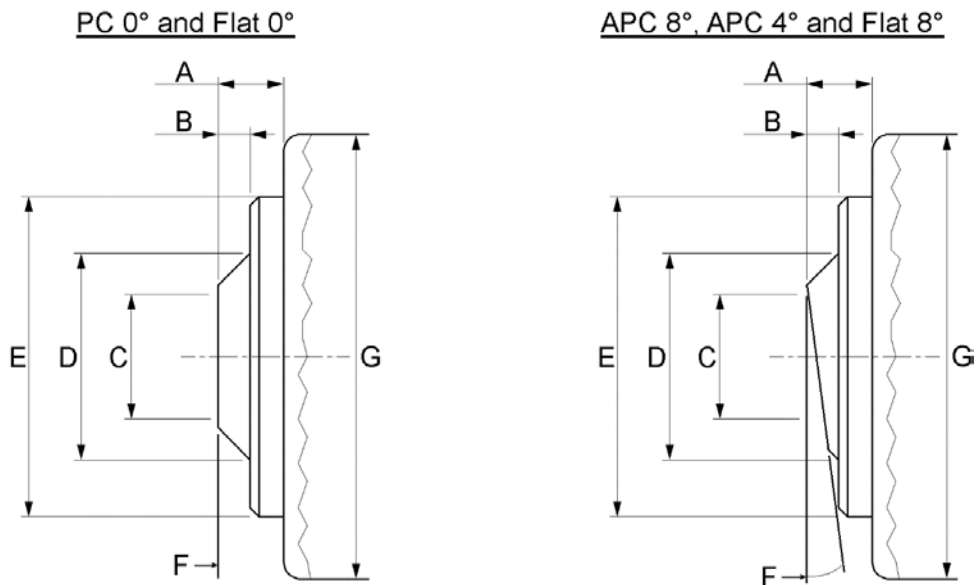

Symbols	Dimensions (mm)		Remarks
	Min	Max	
A	0.37	0.42	
B	0.18	0.23	
ØC	0.66	0.72	
ØD	1.155	1.165	
ØE	1.75	1.85	
F	0°		See Para. 1.7.5.1
	4° or 8°		See Para. 1.7.5.2
ØG	2.499	2.4992	Ferrule outer diameter. For optical function: SM, PM, PS, PM-PS

1.7.5.1 Polishing Type Codes: PC 0° and Flat 0°

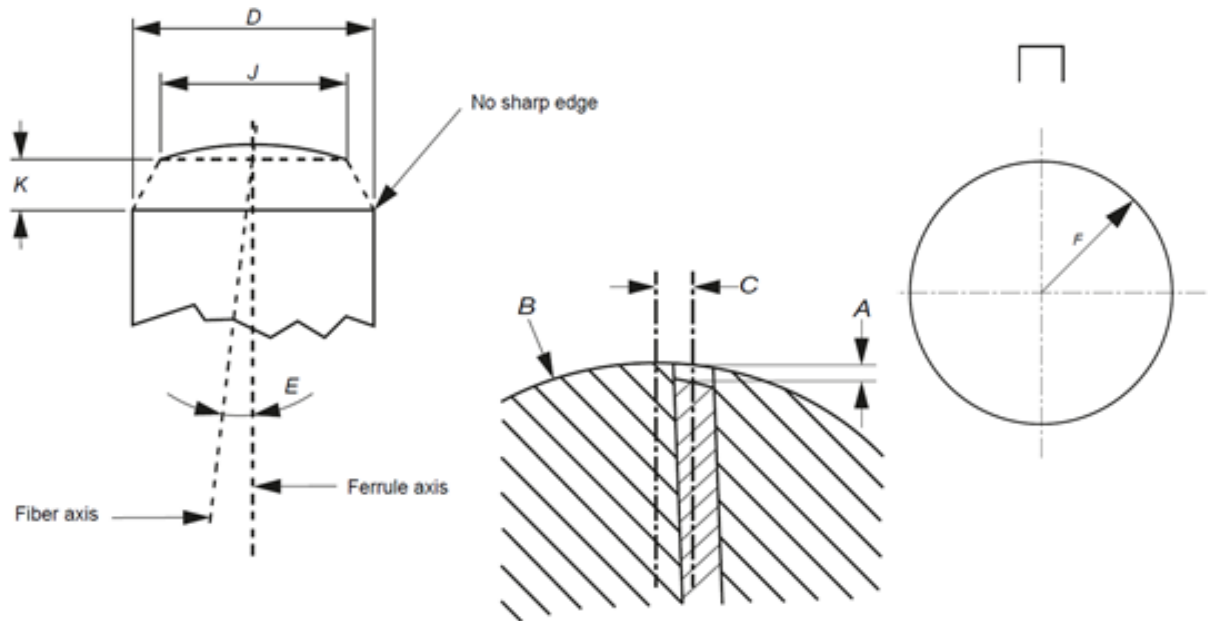

Symbols	Dimensions (1)		Remarks
	Min	Max	
A	-0.0002	+0.0002	Optical fibre undercut/protrusion
B	7	20	Ferrule radius for polishing type code: PC 0°
	40	-	Ferrule radius for polishing type code: Flat 0°
C	-	0.0625	Apex offset for polishing type code: PC 0°
	-	N/A	Apex offset for polishing type code: Flat 0°
E	-0.6°	0.6°	Exit angle; only for optical functions: SM, PM
	-0.1°	0.1°	Exit angle; only for optical functions: PS, PM-PS
F	-	0.00025	Eccentricity of fibre core to the centre of the ferrule; only for optical functions: SM, PM
	-	0.007	Eccentricity of fibre core to the centre of the ferrule; only for optical functions: PS, PM-PS
G	-0.6°	0.6°	Angle of polished surface for polishing type code: PC 0° and Flat 0°

NOTES:

1. mm unless otherwise specified.

1.7.5.2 Polishing Type Codes: APC 4°, APC 8° and Flat 8°

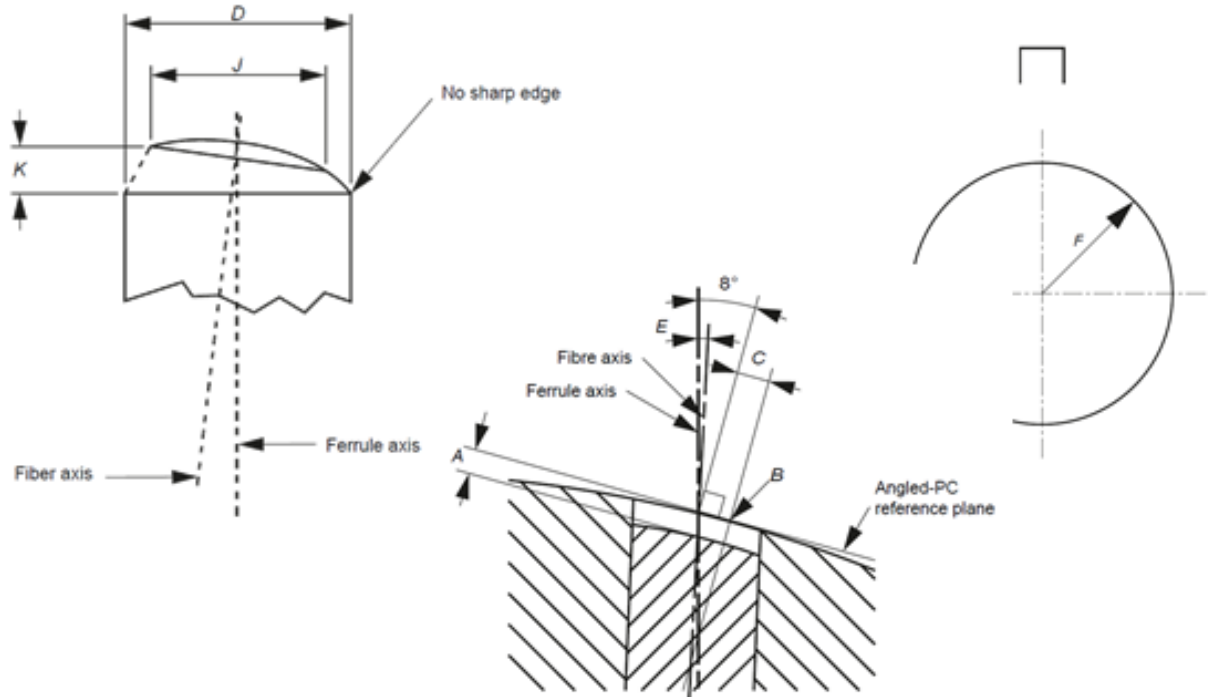

Symbols	Dimensions (1)		Remarks
	Min	Max	
A	-0.0002	+0.0002	Optical fibre undercut/protrusion
B	7	20	Ferrule radius for polishing type code: APC 4° and APC 8°
	40	-	Ferrule radius for polishing type code: Flat 8°
C	-	0.0625	Apex offset for polishing type code: APC 4° and APC 8°
	-	N/A	Apex offset for polishing type code: Flat 8°
E	-0.6°	0.6°	Exit angle; only for optical functions: SM, PM
	-0.1°	0.1°	Exit angle; only for optical functions: PS, PM-PS
F	-	0.00025	Eccentricity of fibre core to the centre of the ferrule; only for optical functions: SM, PM
	-	0.007	Eccentricity of fibre core to the centre of the ferrule; only for optical functions: PS, PM-PS
G	3.4°	4.6°	Angle of polished surface for polishing type code: APC 4°
	7.4°	8.6°	Angle of polished surface for polishing type code: APC 8° and Flat 8°

NOTES:

1. mm unless otherwise specified.

1.7.6 Optical Fibre

1.7.6.1 *Optical Fibre Type Code 01: Optical Functions: PM and PM-PS*

Polarization Maintaining Panda Optical Fibre with Optical Function PM

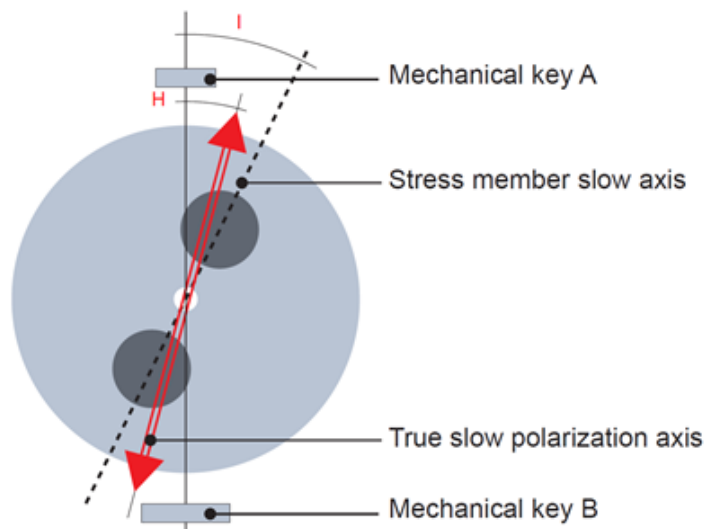
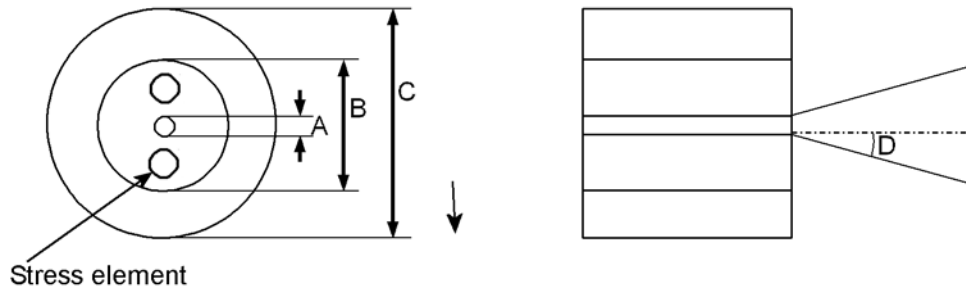

Optical Function PM-PS (Note 2)

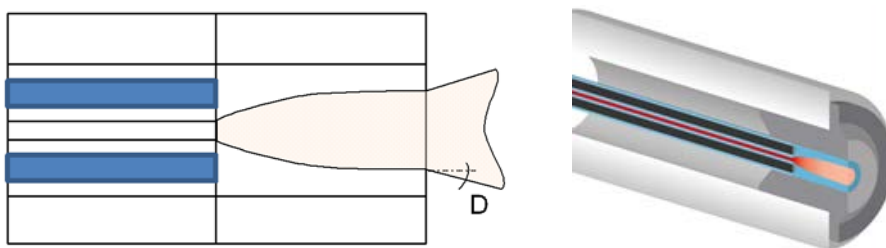

Optical Fibre Type Code	Symbols	Dimensions (1)		Optical Function	Remarks
		Min	Max		
01 (SM.15-P-8/125-UV/UV-400)	ØA	9.5	11.5	PM	Mode Field Diameter
		30	53	PM-PS	Mode Field Diameter
	ØB	122	128	PM	Glass cladding outside diameter
		123	127	PM-PS	Glass cladding outside diameter
	ØC	380	420	PM, PM-PS	Coating outside diameter
	D	0.1	0.14	PM	Numerical Aperture, Note 3
		0.03	0.05	PM-PS	Numerical Aperture, Note 3
	H	-2°	+2°	PM, PM-PS	Orientation angle of the true slow polarization axis of the fibre relative to the connector mechanical keys A and B; see Paras. 1.7.4.1 and 1.7.4.2.
	I	-2°	+2°	PM	Orientation angle of the optical fibre stress member axis relative to the connector mechanical keys A and B; see Paras. 1.7.4.1 and 1.7.4.2. Note 4

NOTES:

1. μm unless otherwise specified.
2. Optical function PM-PS includes a graded index lens spliced at the end of the fibre.
3. Defined at $1/e^2$ and at the nominal operating wavelength of the optical fibre.
4. Dimension H is the default requirement. Dimension I only applies when Dimension H cannot be determined.

1.7.6.2 *Optical Fibre Type Codes 02 and 03: Optical Functions: SM and PS*
Single Mode Fibre with Optical Function SM

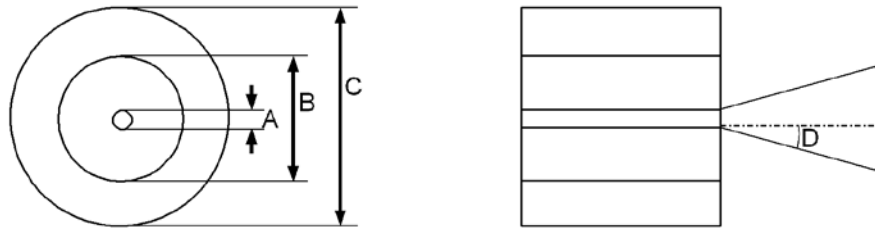

Optical Function PS (Note 2)

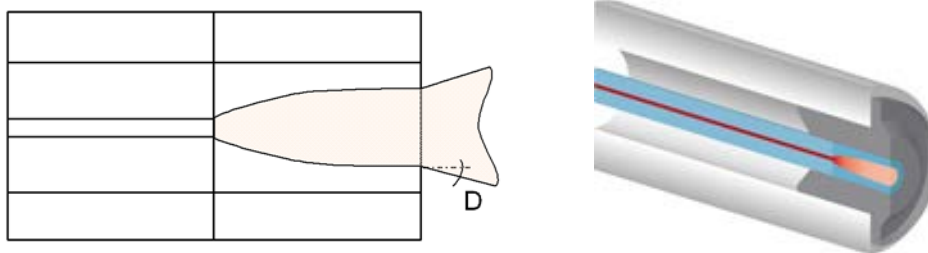

Optical Fibre Type Code	Symbols	Dimensions (1)		Optical Function	Remarks
		Min	Max		
02 (HI-1060-H)	ØA	5.3		SM	Mode Field Diameter
		24	40	PS	Mode Field Diameter
	ØB	120	130	SM	Glass cladding outside diameter
		123	127	PS	Glass cladding outside diameter
	ØC	235	255	SM, PS	Coating outside diameter
	D	0.1	0.14	SM	Numerical Aperture, Note 3
0.02		0.03	PS	Numerical Aperture, Note 3	
03 (SMF-28e+)	ØA	8.2		SM	Mode Field Diameter
		24	40	PS	Mode Field Diameter
	ØB	124.3	125.7	SM	Glass cladding outside diameter
		123	127	PS	Glass cladding outside diameter
	ØC	240	250	SM, PS	Coating outside diameter
	D	0.1	0.14	SM	Numerical Aperture, Note 3
0.03		0.05	PS	Numerical Aperture, Note 3	

NOTES:

1. μm unless otherwise specified.
2. Optical function PS includes a graded index lens spliced at the end of the fibre.
3. Defined at $1/e^2$ and at the nominal operating wavelength of the optical fibre.

1.7.7 Cable

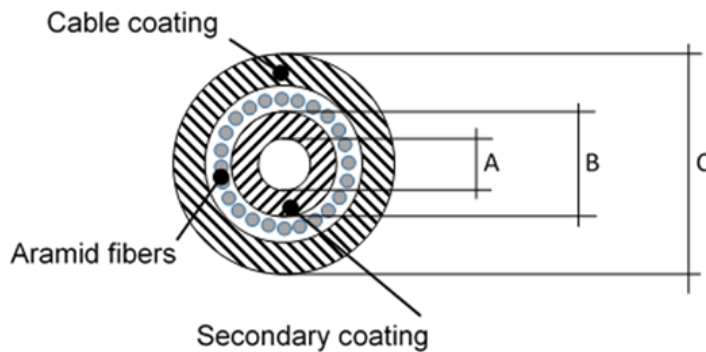

Cable Type Code	Dimensions (mm)					
	ØA		ØB		ØC	
	Min	Max	Min	Max	Min	Max
P, S (PEEK Loose Tube)	0.4	0.5	0.9	1.1	N/A	N/A
H (Elastomeric Loose Tube)	0.4	0.6	0.8	1.1	N/A	N/A
C (Aramid Reinforced LSOH Coated Cable)	0.4	0.6	0.8	1.1	2	2.2

1.8 MATERIALS AND FINISHES

Specific materials and finishes shall be as follows:

- (a) Optical fibre:
 - Type Code 01 (SM.15-P-8/125-UV/UV-400):
 - Manufacturer: Fujikura
 - Type: Polarization maintaining (panda)
 - Coating: Acrylate
 - Type Code 02 (HI-1060-H):
 - Manufacturer: Corning
 - Type: Single mode, high index
 - Coating: Acrylate
 - Type Code 03 (SMF-28e+):
 - Manufacturer: Corning
 - Type: Single mode
 - Coating: Acrylate
- (b) Cable:
 - Type Codes P, S: unreinforced Polyetheretherketone; colour: natural/beige
 - Type Code H: Elastomer; colour: transparent
 - Type Code C: Aramid reinforced cable with zero halogen LSOH cable coating; colour: yellow
- (c) Optical Connector Anti-flexion Boot: thermoplastic polyester elastomer; colour:
 - Blue for polishing type PC 0°
 - Red for polishing type APC 4°
 - Green for polishing type APC 8°
 - Black for polishing types Flat 0° and Flat 8°

2 REQUIREMENTS

2.1 GENERAL

The complete requirements for procurement of the components specified herein are as stated in this specification and the ESCC Generic Specification. Permitted deviations from the Generic Specification, applicable to this specification only, are listed below.

Permitted deviations from the Generic Specification and this Detail Specification, formally agreed with specific Manufacturers on the basis that the alternative requirements are equivalent to the ESCC requirement and do not affect the component's reliability, are listed in the appendices attached to this specification.

2.1.1 Deviations from the Generic Specification

2.1.1.1 *Deviations from Screening Tests – Chart F3*

- (a) For Variants 02, 03 (mating adaptors): only the following tests and inspections shall be performed on each lot of components during Chart F3 tests:
- i. Serialisation (ref. Para. 6.1)
 - ii. Sinusoidal Vibration (ref. Para. 8.8)
 - iii. Insertion Loss: Each mating adaptor shall be subjected to 5 mate/measurement/de-mate test cycles as follows:
 1. The mating adaptor under test shall be mated with two suitable optical fibre (reference) cable assemblies. The Insertion Loss of each reference cable assembly shall have been measured successfully prior to this testing (ref. Para. 2.3.2 herein).
 2. Insertion Loss of the complete test assembly shall be recorded (ref. Para. 2.3.2 herein). Variation of Insertion Loss shall be calculated for each test cycle and shall be within 0.1dB for all 5 cycles. All failures shall be rejected.
 3. After performance of the Insertion Loss measurement, the mating adaptor under test shall be de-mated from the two reference cable assemblies.
 - iv. External Visual Inspection (ref. Para. 8.5)
 - v. Check for Lot Failure (ref. Para. 6.4)

2.1.1.2 *Deviations from Qualification and Periodic Testing – Chart F4*

- (a) Para. 8.11, Random Vibration: The following deviation shall apply:
- Shape of acceleration spectral density curve:
 - From 20Hz to 100Hz, power spectral density (PSD) changing by +6dB/Octave

2.2 MARKING

The marking shall be in accordance with the requirements of ESCC Basic Specification No. [21700](#) and as follows.

The information to be marked on the component shall be:

- (a) The ESCC qualified components symbol (for ESCC qualified components only).
- (b) The ESCC Component Number (see Para. 1.4.1)
- (c) Traceability information.

2.3 ROOM TEMPERATURE OPTICAL AND GEOMETRICAL MEASUREMENTS

The measurements shall be performed at $T_{amb} = +22 \pm 3^{\circ}\text{C}$.

2.3.1 Geometrical Measurements (Variants 01, 04, 05, 06)

Characteristics		Symbols	ESCC No. 3420 Test Method and Conditions	Limits		Units
				Min	Max	
End-face Geometry	Apex Offset	AO	Para. 8.6.1.5 Polishing type code: <ul style="list-style-type: none"> PC 0°, APC 4°, APC 8° Flat 0°, Flat 8° 	- N/A	62.5 N/A	μm
	Radius of Curvature	RC	Para. 8.6.1.5 Polishing type code: <ul style="list-style-type: none"> PC 0°, APC 4°, APC 8° Flat 0°, Flat 8° 	7 40	20 -	mm
	Optical Fibre Protrusion	OFP	Para. 8.6.1.5 Polishing type code: all	-200	+200	nm

2.3.2 Optical Measurements (Variants 01, 04, 05, 06)

(a) Optical Fibre Cable Assemblies using optical fibre Type Code 01 (SM.15-P-8/125-UV/UV-400):

Characteristics	Symbols	ESCC No. 3420 Test Method and Conditions	Limits		Units
			Min	Max	
Insertion Loss	IL	Para. 8.6.1.1 Test wavelength = 1550nm Optical function/Polishing: <ul style="list-style-type: none"> PM / PC 0° PM / APC 8° PM / Flat 0° PM / Flat 8° PM-PS / PC 0° PM-PS / APC 4° 	- - - - - -	0.5 0.5 N/A N/A 1 1	dB
Transient Loss Threshold	TL	Para. 8.6.1.2 Test wavelength = 1550nm	0.5	-	dB
Return Loss	RL	Para. 8.6.1.3 Test wavelength = 1550nm Optical function/Polishing: <ul style="list-style-type: none"> PM / PC 0° PM / APC 8° PM / Flat 0° PM / Flat 8° PM-PS / PC 0° PM-PS / APC 4° 	50 70 10 10 35 55	- - - - - -	dB
Polarization Extinction Ratio	PER	Para. 8.6.1.4 Test wavelength = 1550nm Optical function: <ul style="list-style-type: none"> PM PM-PS 	21 18	- -	dB
Polarization Angle	PA	Para. 8.6.1.4 Test wavelength = 1550nm	-2	+2	°

(b) Optical Fibre Cable Assemblies using optical fibre Type Code 02 (HI-1060-H):

Characteristics	Symbols	ESCC No. 3420 Test Method and Conditions	Limits		Units
			Min	Max	
Insertion Loss	IL	Para. 8.6.1.1 Test wavelength = 980nm Optical function/Polishing: <ul style="list-style-type: none"> • SM / PC 0° • SM / APC 8° • SM / Flat 0° • SM / Flat 8° • PS / PC 0° • PS / APC 4° 	-	0.5	dB
Transient Loss Threshold	TL	Para. 8.6.1.2 Test wavelength = 980nm	0.5	-	dB
Return Loss	RL	Para. 8.6.1.3 Test wavelength = 980nm Optical function/Polishing: <ul style="list-style-type: none"> • SM / PC 0° • SM / APC 8° • SM / Flat 0° • SM / Flat 8° • PS / PC 0° • PS / APC 4° 	50	-	dB
			60	-	
			10	-	
			10	-	
			35	-	
			60	-	

(c) Optical Fibre Cable Assemblies using optical fibre Type Code 03 (SMF-28e+):

Characteristics	Symbols	ESCC No. 3420 Test Method and Conditions	Limits		Units
			Min	Max	
Insertion Loss	IL	Para. 8.6.1.1 Test wavelength = 1550nm Optical function/Polishing: <ul style="list-style-type: none"> • SM / PC 0° • SM / APC 8° • SM / Flat 0° • SM / Flat 8° • PS / PC 0° • PS / APC 4° 	-	0.5	dB
Transient Loss Threshold	TL	Para. 8.6.1.2 Test wavelength = 1550nm	0.5	-	dB
Return Loss	RL	Para. 8.6.1.3 Test wavelength = 1550nm Optical function/Polishing: <ul style="list-style-type: none"> • SM / PC 0° • SM / APC 8° • SM / Flat 0° • SM / Flat 8° • PS / PC 0° • PS / APC 4° 	50	-	dB
			75	-	
			10	-	
			10	-	
			45	-	
			75	-	

2.4 PARAMETER DRIFT VALUES

Unless otherwise specified, the measurements shall be performed at $T_{amb} = +22 \pm 3^{\circ}\text{C}$.

The test methods and test conditions shall be as per the corresponding test defined in Para. 2.3 Room Temperature Optical and Geometrical Measurements.

The drift values (Δ) shall not be exceeded for each characteristic where specified. The corresponding absolute limit values for each characteristic shall not be exceeded.

Characteristics	Symbols	Drift Value Δ		Units	
		Drift Value Δ	Absolute		
			Min		Max
Insertion Loss	IL	± 0.4	As per Para. 2.3		dB

2.5 INTERMEDIATE AND END-POINT OPTICAL AND GEOMETRICAL MEASUREMENTS

Unless otherwise specified, the measurements shall be performed at $T_{amb} = +22 \pm 3^{\circ}\text{C}$.

Unless otherwise specified, test methods and test conditions shall be as per the corresponding test defined in Para. 2.3 Room Temperature Optical and Geometrical Measurements.

The drift values (Δ) shall not be exceeded for each characteristic where specified. The corresponding absolute limit values for each characteristic shall not be exceeded.

Test Reference per ESCC No. 3420	Characteristics	Symbols	Limits		Units	
			Min	Max		
Temperature Cycling Initial Measurements	Insertion Loss	IL	As per Para. 2.3		dB	
	Return Loss	RL	As per Para. 2.3			
	Polarization Extinction Ratio	PER	As per Para. 2.3			
	End-face Geometry:					
	Apex Offset	AO	As per Para. 2.3			
	Radius of Curvature	RC	As per Para. 2.3			
Measurements during testing.	Optical Fibre Protrusion	OFF	As per Para. 2.3			
	Variation of Insertion Loss	Δ IL	-0.4	+0.4		
Final Measurements	Insertion Loss	IL	As per Para. 2.3			
	Return Loss	RL	As per Para. 2.3			
	Polarization Extinction Ratio	PER	As per Para. 2.3			
	End-face Geometry:					
	Apex Offset	AO	As per Para. 2.3			
	Radius of Curvature	RC	As per Para. 2.3			
	Optical Fibre Protrusion	OFF	As per Para. 2.3			

Test Reference per ESCC No. 3420	Characteristics	Symbols	Limits		Units
			Min	Max	
Humidity Cycling Initial Measurements Measurements during testing. Final Measurements	Insertion Loss	IL	As per Para. 2.3		dB
	Return Loss	RL	As per Para. 2.3		
	Polarization Extinction Ratio	PER	As per Para. 2.3		
	End-face Geometry:				
	Apex Offset	AO	As per Para. 2.3		
	Radius of Curvature	RC	As per Para. 2.3		
	Optical Fibre Protrusion	OFP	As per Para. 2.3		
	Variation of Insertion Loss	Δ IL	-0.4	+0.4	
	Insertion Loss	IL	As per Para. 2.3		
	Return Loss	RL	As per Para. 2.3		
	Polarization Extinction Ratio	PER	As per Para. 2.3		
	End-face Geometry:				
Apex Offset	AO	As per Para. 2.3			
Radius of Curvature	RC	As per Para. 2.3			
Optical Fibre Protrusion	OFP	As per Para. 2.3			
Random Vibration Initial Measurements Measurements during testing. Final Measurements	Insertion Loss	IL	As per Para. 2.3		dB
	Return Loss	RL	As per Para. 2.3		
	Polarization Extinction Ratio	PER	As per Para. 2.3		
	End-face Geometry:				
	Apex Offset	AO	As per Para. 2.3		
	Radius of Curvature	RC	As per Para. 2.3		
	Optical Fibre Protrusion	OFP	As per Para. 2.3		
	Variation of Insertion Loss	Δ IL	-0.4	+0.4	
	Transient Loss Threshold	TL	As per Para. 2.3		
	Insertion Loss	IL	As per Para. 2.3		
	Return Loss	RL	As per Para. 2.3		
	Polarization Extinction Ratio	PER	As per Para. 2.3		
End-face Geometry:					
Apex Offset	AO	As per Para. 2.3			
Radius of Curvature	RC	As per Para. 2.3			
Optical Fibre Protrusion	OFP	As per Para. 2.3			

Test Reference per ESCC No. 3420	Characteristics	Symbols	Limits		Units	
			Min	Max		
Mechanical Shock Initial Measurements	Insertion Loss	IL	As per Para. 2.3		dB	
	Return Loss	RL	As per Para. 2.3			
	Polarization Extinction Ratio	PER	As per Para. 2.3			
	End-face Geometry:					
	Apex Offset	AO	As per Para. 2.3			
	Radius of Curvature	RC	As per Para. 2.3			
	Optical Fibre Protrusion	OFP	As per Para. 2.3			
	Measurements during testing.	Variation of Insertion Loss	Δ IL	-0.4		+0.4
		Transient Loss Threshold	TL	As per Para. 2.3		
	Final Measurements	Insertion Loss	IL	As per Para. 2.3		
Return Loss		RL	As per Para. 2.3			
Polarization Extinction Ratio		PER	As per Para. 2.3			
End-face Geometry:						
Apex Offset		AO	As per Para. 2.3			
Radius of Curvature		RC	As per Para. 2.3			
Optical Fibre Protrusion		OFP	As per Para. 2.3			
Torsion Initial Measurements		Insertion Loss	IL	As per Para. 2.3		dB
		Return Loss	RL	As per Para. 2.3		
		Polarization Extinction Ratio	PER	As per Para. 2.3		
	End-face Geometry:					
	Apex Offset	AO	As per Para. 2.3			
	Radius of Curvature	RC	As per Para. 2.3			
	Optical Fibre Protrusion	OFP	As per Para. 2.3			
	Measurements during testing.	Variation of Insertion Loss	Δ IL	-0.4	+0.4	
	Final Measurements	Insertion Loss	IL	As per Para. 2.3		
		Return Loss	RL	As per Para. 2.3		
Polarization Extinction Ratio		PER	As per Para. 2.3			
End-face Geometry:						
Apex Offset		AO	As per Para. 2.3			
Radius of Curvature		RC	As per Para. 2.3			
Optical Fibre Protrusion		OFP	As per Para. 2.3			

Test Reference per ESCC No. 3420	Characteristics	Symbols	Limits		Units
			Min	Max	
Static Side Load Initial Measurements	Insertion Loss Return Loss Polarization Extinction Ratio End-face Geometry: Apex Offset Radius of Curvature Optical Fibre Protrusion	IL RL PER AO RC OFP	As per Para. 2.3 As per Para. 2.3 As per Para. 2.3 As per Para. 2.3 As per Para. 2.3 As per Para. 2.3		dB
Measurements during testing.	Variation of Insertion Loss	Δ IL	-0.4	+0.4	
Final Measurements	Insertion Loss Return Loss Polarization Extinction Ratio End-face Geometry: Apex Offset Radius of Curvature Optical Fibre Protrusion	IL RL PER AO RC OFP	As per Para. 2.3 As per Para. 2.3 As per Para. 2.3 As per Para. 2.3 As per Para. 2.3 As per Para. 2.3		
Optical Fibre/Cable Retention Initial Measurements	Insertion Loss Return Loss Polarization Extinction Ratio End-face Geometry: Apex Offset Radius of Curvature Optical Fibre Protrusion	IL RL PER AO RC OFP	As per Para. 2.3 As per Para. 2.3 As per Para. 2.3 As per Para. 2.3 As per Para. 2.3 As per Para. 2.3		dB
Measurements during testing.	Variation of Insertion Loss	Δ IL	-0.4	+0.4	
Final Measurements	Insertion Loss Return Loss Polarization Extinction Ratio End-face Geometry: Apex Offset Radius of Curvature Optical Fibre Protrusion	IL RL PER AO RC OFP	As per Para. 2.3 As per Para. 2.3 As per Para. 2.3 As per Para. 2.3 As per Para. 2.3 As per Para. 2.3		

Test Reference per ESCC No. 3420	Characteristics	Symbols	Limits		Units
			Min	Max	
High Temperature Storage Initial Measurements	Insertion Loss	IL	As per Para. 2.3		
	Return Loss	RL	As per Para. 2.3		
	Polarization Extinction Ratio	PER	As per Para. 2.3		
	End-face Geometry:		As per Para. 2.3		
	Apex Offset	AO	As per Para. 2.3		
	Radius of Curvature	RC	As per Para. 2.3		
	Optical Fibre Protrusion	OFP	As per Para. 2.3		
Final Measurements	Insertion Loss	IL	As per Para. 2.3		
	Return Loss	RL	As per Para. 2.3		
	Polarization Extinction Ratio	PER	As per Para. 2.3		
	End-face Geometry:		As per Para. 2.3		
	Apex Offset	AO	As per Para. 2.3		
	Radius of Curvature	RC	As per Para. 2.3		
	Optical Fibre Protrusion	OFP	As per Para. 2.3		
Mating Durability Initial Measurements	Insertion Loss	IL	As per Para. 2.3		dB
	Return Loss	RL	As per Para. 2.3		
	Polarization Extinction Ratio	PER	As per Para. 2.3		
	End-face Geometry:		As per Para. 2.3		
	Apex Offset	AO	As per Para. 2.3		
	Radius of Curvature	RC	As per Para. 2.3		
	Optical Fibre Protrusion	OFP	As per Para. 2.3		
Measurements during testing.	Variation of Insertion Loss	Δ IL	-0.4	+0.4	
Final Measurements	Insertion Loss	IL	As per Para. 2.3		
	Return Loss	RL	As per Para. 2.3		
	Polarization Extinction Ratio	PER	As per Para. 2.3		
	End-face Geometry:		As per Para. 2.3		
	Apex Offset	AO	As per Para. 2.3		
	Radius of Curvature	RC	As per Para. 2.3		
	Optical Fibre Protrusion	OFP	As per Para. 2.3		

APPENDIX A
AGREED DEVIATIONS FOR DIAMOND SA (CH)

Items Affected	Description of Deviations		
Para. 2.1.1.1, Deviations from the Generic Specification: Deviations from Screening Tests – Chart F3	On completion of Screening Tests and prior to delivery, the components' ferrules including the end-face surface may be subjected to a polishing process in accordance with Diamond SA procedure DF-51 as specified in the PID.		
Para. 2.1.1, Deviations from the Generic Specification: Optical and Geometrical Measurements	Para. 8.6.1.4, Polarization Extinction Ratio: Polarization Extinction Ratio may be measured on the component in accordance with the Diamond SA PER test procedure as specified in the PID.		
Para. 1.4.1.1(d), The ESCC Component Number - Characteristics Codes - Optical Connector B Type	The following code may be used to cover the use of any alternative, commercial optical connector on Side B of the optical cable assembly, which is intended for use on an unqualified basis for non-space applications. Additional Manufacturer's own marking may be used to distinguish the specific type of Side B connector in use.		
	Optical Connector B Type	Code	Remarks
	Any Commercial Connector	C	Use to cover any alternative, commercial optical connectors. e.g. E-2000, FC