



Page 1 of 23

**INTEGRATED CIRCUITS, SILICON MONOLITHIC, HCMOS
OCTAL BUS TRANSCEIVER WITH 3-STATE OUTPUTS**

BASED ON TYPE 54HC245

ESCC Detail Specification No. 9405/013

Issue 6	May 2019
---------	----------



Document Custodian: European Space Agency – see <https://escies.org>

LEGAL DISCLAIMER AND COPYRIGHT

European Space Agency, Copyright © 2019. All rights reserved.

The European Space Agency disclaims any liability or responsibility, to any person or entity, with respect to any loss or damage caused, or alleged to be caused, directly or indirectly by the use and application of this ESCC publication.

This publication, without the prior permission of the European Space Agency and provided that it is not used for a commercial purpose, may be:

- copied in whole, in any medium, without alteration or modification.
- copied in part, in any medium, provided that the ESCC document identification, comprising the ESCC symbol, document number and document issue, is removed.

DOCUMENTATION CHANGE NOTICE

(Refer to <https://escies.org> for ESCC DCR content)

DCR No.	CHANGE DESCRIPTION
1184 1200 1258	Specification upissued to incorporate changes per DCR.

TABLE OF CONTENTS

1	GENERAL	5
1.1	SCOPE	5
1.2	APPLICABLE DOCUMENTS	5
1.3	TERMS, DEFINITIONS, ABBREVIATIONS, SYMBOLS AND UNITS	5
1.4	THE ESCC COMPONENT NUMBER AND COMPONENT TYPE VARIANTS	5
1.4.1	The ESCC Component Number	5
1.4.2	Component Type Variants	5
1.5	MAXIMUM RATINGS	6
1.6	HANDLING PRECAUTIONS	6
1.7	PHYSICAL DIMENSIONS AND TERMINAL IDENTIFICATION	7
1.7.1	Flat Package (FP) - 20 Pin	7
1.7.2	Dual-in-line Package (DIP) - 20 Pin	8
1.7.3	Notes to Para. 1.7 Physical Dimensions and Terminal Identification	9
1.8	FUNCTIONAL DIAGRAM	9
1.9	PIN ASSIGNMENT	10
1.10	TRUTH TABLE	10
1.11	PROTECTION NETWORKS	10
2	REQUIREMENTS	11
2.1	GENERAL	11
2.1.1	Deviations from the Generic Specification	11
2.2	MARKING	11
2.3	ELECTRICAL MEASUREMENTS AT ROOM, HIGH AND LOW TEMPERATURES	11
2.3.1	Room Temperature Electrical Measurements	11
2.3.2	High and Low Temperatures Electrical Measurements	15
2.3.3	Notes to Electrical Measurement Tables	18
2.4	PARAMETER DRIFT VALUES	19
2.5	INTERMEDIATE AND END-POINT ELECTRICAL MEASUREMENTS	20
2.6	HIGH TEMPERATURE REVERSE BIAS BURN-IN CONDITIONS	21
2.6.1	N-Channel HTRB	21
2.6.2	P-Channel HTRB	21
2.7	POWER BURN-IN CONDITIONS	21
2.8	OPERATING LIFE CONDITIONS	22
2.9	TOTAL DOSE RADIATION TESTING	22
2.9.1	Bias Conditions and Total Dose Level for Total Dose Radiation Testing	22
2.9.2	Electrical Measurements for Total Dose Radiation Testing	22
	APPENDIX 'A'	23

1 GENERAL

1.1 SCOPE

This specification details the ratings, physical and electrical characteristics and test and inspection data for the component type variants and/or the range of components specified below. It supplements the requirements of, and shall be read in conjunction with, the ESCC Generic Specification listed under Applicable Documents.

1.2 APPLICABLE DOCUMENTS

The following documents form part of this specification and shall be read in conjunction with it:

- (a) ESCC Generic Specification No. [9000](#)
- (b) [MIL-STD-883](#), Test Methods and Procedures for Microelectronics

1.3 TERMS, DEFINITIONS, ABBREVIATIONS, SYMBOLS AND UNITS

For the purpose of this specification, the terms, definitions, abbreviations, symbols and units specified in ESCC Basic Specification No. [21300](#) shall apply.

1.4 THE ESCC COMPONENT NUMBER AND COMPONENT TYPE VARIANTS

1.4.1 The ESCC Component Number

The ESCC Component Number shall be constituted as follows:

Example: 940501301F

- Detail Specification Reference: 9405013
- Component Type Variant Number: 01 (as required)
- Total Dose Radiation Level Letter: F (as required)

1.4.2 Component Type Variants

The component type variants applicable to this specification are as follows:

Variant Number	Based on Type	Case	Terminal Material and Finish	Weight max g	Total Dose Radiation Level Letter
01	54HC245	FP	G2	0.9	F [50kRAD(Si)]
02	54HC245	FP	G4	0.9	F [50kRAD(Si)]
03	54HC245	DIP	G2	3.2	F [50kRAD(Si)]
04	54HC245	DIP	G4	3.2	F [50kRAD(Si)]

The terminal material and finish shall be in accordance with the requirements of ESCC Basic Specification No. [23500](#).

The total dose radiation level letter shall be as defined in ESCC Basic Specification No. [22900](#). If an alternative radiation test level is specified in the Purchase Order the letter shall be changed accordingly.

1.5 MAXIMUM RATINGS

The maximum ratings shall not be exceeded at any time during use or storage.

Maximum ratings shall only be exceeded during testing to the extent specified in this specification and when stipulated in Test Methods and Procedures of the ESCC Generic Specification.

Characteristics	Symbols	Maximum Ratings	Units	Remarks
Supply Voltage	V_{DD}	-0.5 to 7	V	Note 1
Input Voltage	V_{IN}	-0.5 to $V_{DD}+0.5$	V	Notes 1, 2
Output Voltage	V_{OUT}	-0.5 to $V_{DD}+0.5$	V	Notes 1, 3
Device Power Dissipation (Continuous)	P_D	420	mW	Note 4
Supply Current	I_{DDop}	70	mA	
Operating Temperature Range	T_{op}	-55 to +125	°C	T_{amb}
Storage Temperature Range	T_{stg}	-65 to +150	°C	
Soldering Temperature	T_{sol}	+265	°C	Note 5

NOTES:

1. Device is functional for $2V \leq V_{DD} \leq 6V$.
2. Input current limited to $I_{IC} = \pm 20mA$.
3. Output current limited to $I_{OUT} = \pm 35mA$.
4. The maximum device dissipation is determined by $I_{DDop} \max (70mA) \times 6V$.
5. Duration 10 seconds maximum at a distance of not less than 1.5mm from the device body and the same terminal shall not be resoldered until 3 minutes have elapsed.

1.6 HANDLING PRECAUTIONS

These devices are susceptible to damage by electrostatic discharge. Therefore, suitable precautions shall be employed for protection during all phases of manufacture, testing, packaging, shipment and any handling.

These components are categorised as Class 2 per ESCC Basic Specification No. [23800](#) with a minimum Critical Path Failure Voltage of 2500 Volts.

1.7 PHYSICAL DIMENSIONS AND TERMINAL IDENTIFICATION

Consolidated Notes are given Para. 1.7.3.

1.7.1 Flat Package (FP) - 20 Pin

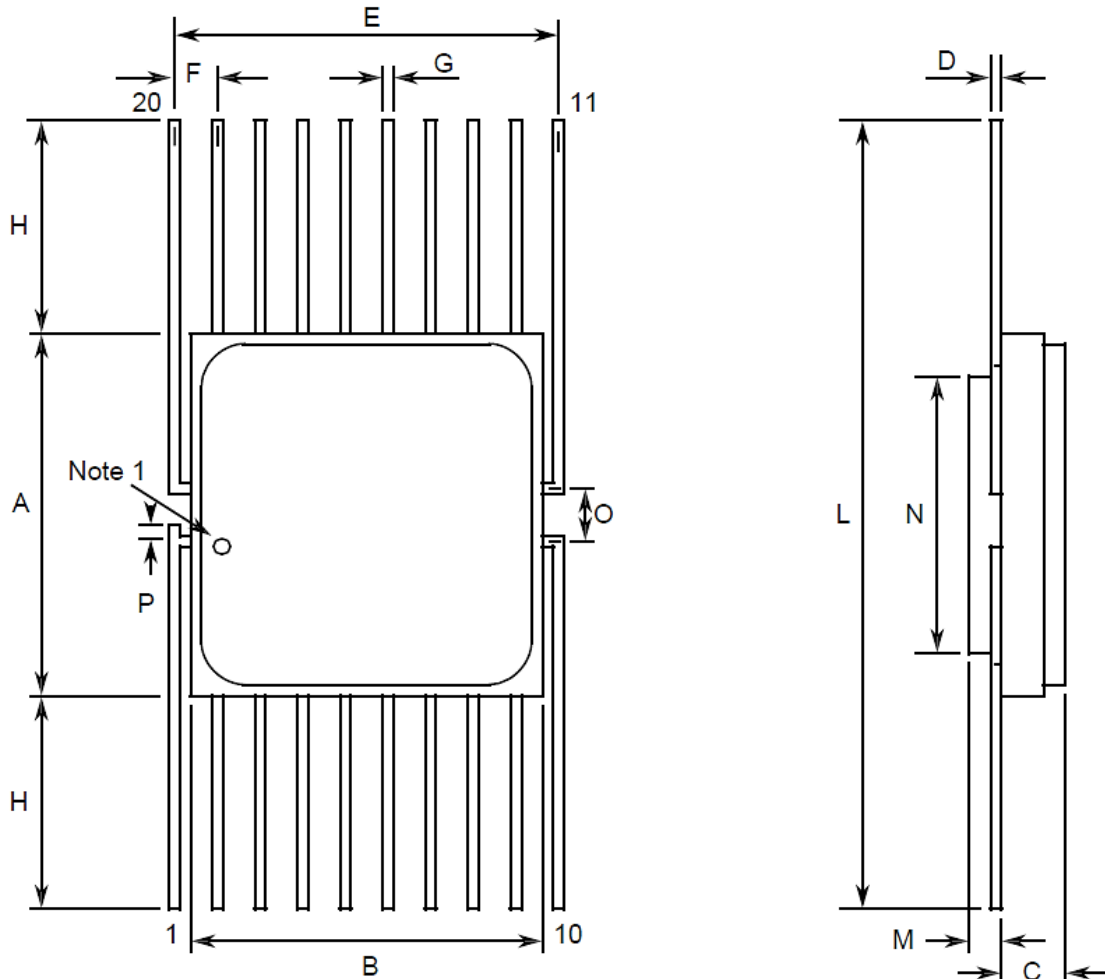

Symbols	Dimensions mm		Notes
	Min	Max	
A	9.98	10.34	
B	9.98	10.34	
C	1.45	1.78	
D	0.1	0.18	5
E	11.3	11.56	
F	1.27 BSC		3, 6
G	0.38	0.48	5
H	7.24	8.16	5
L	24.46	26.67	
M	0.45	0.55	
N	7.87 TYPICAL		
O	1.27 BSC		
P	0.1	0.25	

1.7.2 Dual-in-line Package (DIP) - 20 Pin

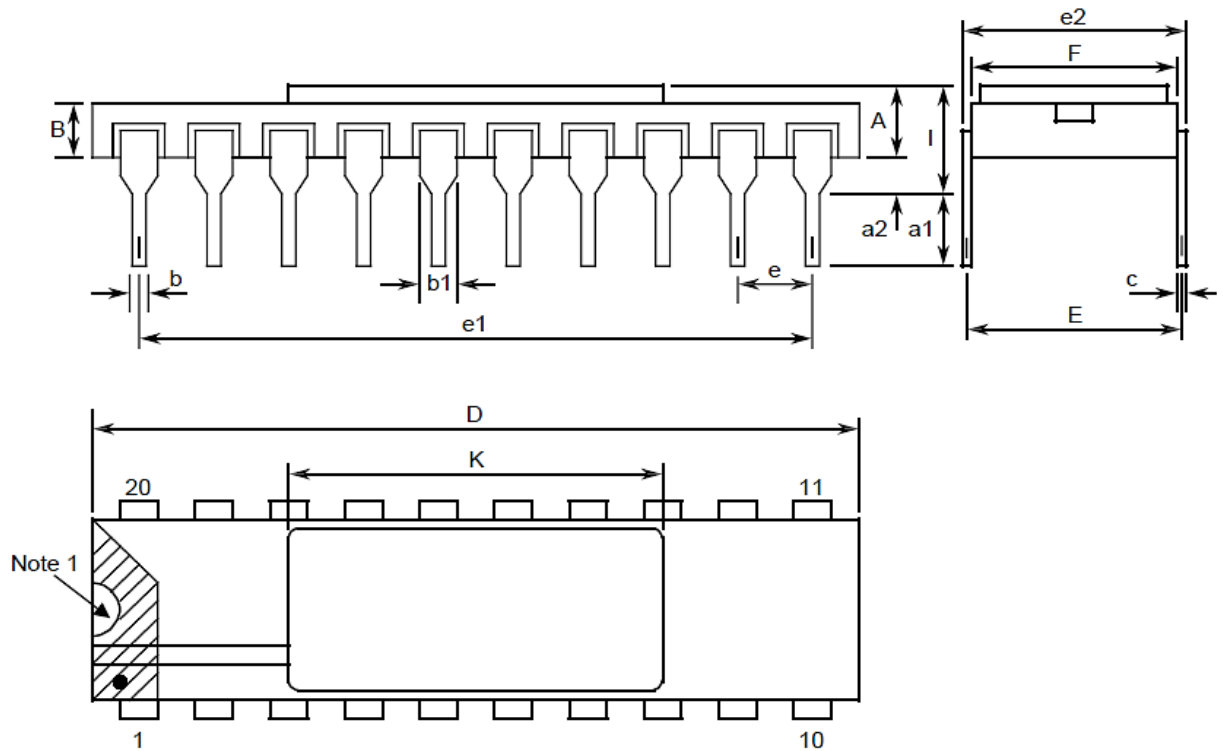

Symbols	Dimensions mm		Notes
	Min	Max	
A	2.1	2.72	
a1	3	3.7	
a2	0.63	1.14	2
B	1.93	2.39	
b	0.4	0.5	5
b1	1.27 TYPICAL		5
c	0.2	0.3	5
D	25.14	25.65	
E	7.36	7.87	
e	2.54 BSC		4, 6
e1	22.73	22.99	
e2	7.62	8.12	
F	7.11	7.62	
I	-	3.86	
K	11.3	11.56	

1.7.3 Notes to Para. 1.7 Physical Dimensions and Terminal Identification

1. Index area; a notch or a dot shall be located adjacent to Pin 1 and shall be within the shaded area shown. For chip carrier packages, the index shall be as shown.
2. The dimension shall be measured from the seating plane to the base plane.
3. The true position pin spacing is 1.27mm between centrelines. Each pin centreline shall be located within $\pm 0.13\text{mm}$ of its true longitudinal position relative to Pin 1 and the highest pin number.
4. The true position pin spacing is 2.54mm between centrelines. Each pin centreline shall be located within $\pm 0.25\text{mm}$ of its true longitudinal position relative to Pin 1 and the highest pin number.
5. All terminals.
6. 18 spaces.

1.8 FUNCTIONAL DIAGRAM

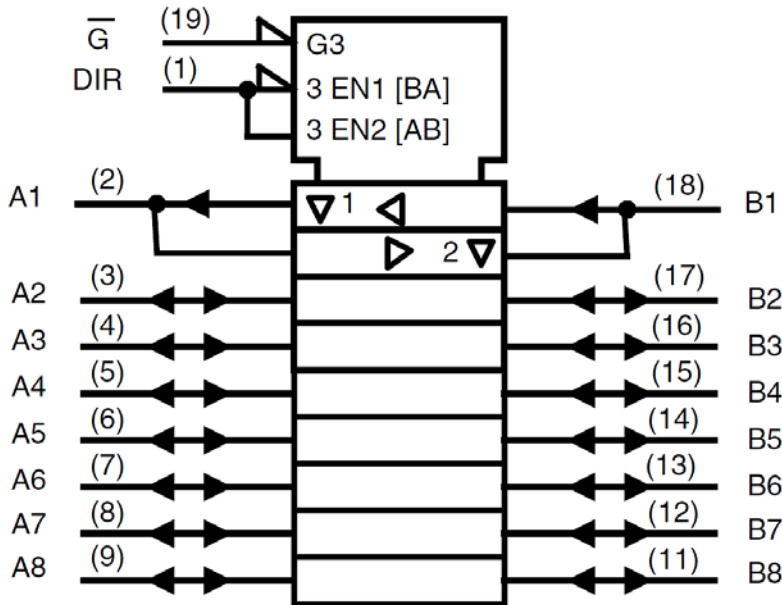

NOTES:

1. The package lid for all packages is not connected to any terminal.

1.9 PIN ASSIGNMENT

Pin	Function	Pin	Function
1	DIR Input (Direction)	11	B8 Input/Output (Data/Bus)
2	A1 Input/Output (Data/Bus)	12	B7 Input/Output (Data/Bus)
3	A2 Input/Output (Data/Bus)	13	B6 Input/Output (Data/Bus)
4	A3 Input/Output (Data/Bus)	14	B5 Input/Output (Data/Bus)
5	A4 Input/Output (Data/Bus)	15	B4 Input/Output (Data/Bus)
6	A5 Input/Output (Data/Bus)	16	B3 Input/Output (Data/Bus)
7	A6 Input/Output (Data/Bus)	17	B2 Input/Output (Data/Bus)
8	A7 Input/Output (Data/Bus)	18	B1 Input/Output (Data/Bus)
9	A8 Input/Output (Data/Bus)	19	\bar{G} Input (Enable)
10	V _{SS}	20	V _{DD}

1.10 TRUTH TABLE

1. Logic Level Definitions: L = Low Level, H = High Level, X = Irrelevant, Z = High Impedance.

EACH TRANSCEIVER

CONTROL INPUTS		OPERATION
\bar{G}	DIR	
L	L	B Data to A Bus
L	H	A Data to B Bus
H	X	A and B = Z

1.11 PROTECTION NETWORKS

INPUT PROTECTION

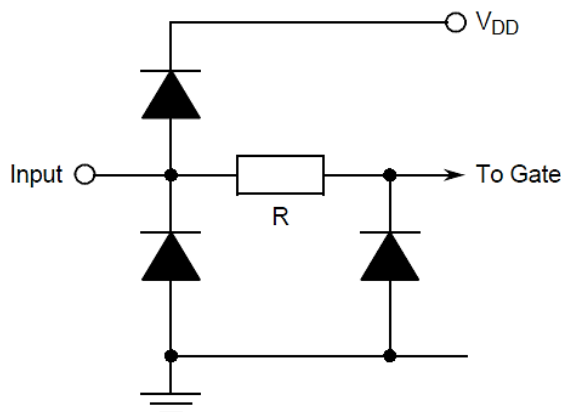

OUTPUT PROTECTION

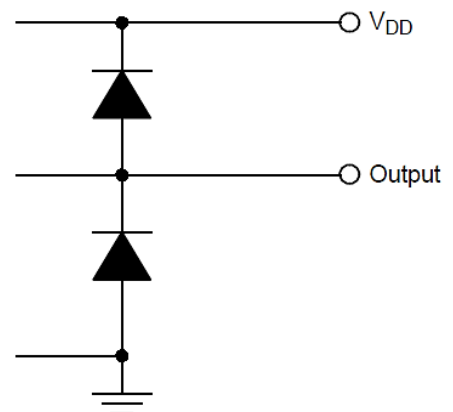

2 REQUIREMENTS

2.1 GENERAL

The complete requirements for procurement of the components specified herein are as stated in this specification and the ESCC Generic Specification. Permitted deviations from the Generic Specification, applicable to this specification only, are listed below.

Permitted deviations from the Generic Specification and this Detail Specification, formally agreed with specific Manufacturers on the basis that the alternative requirements are equivalent to the ESCC requirement and do not affect the component's reliability, are listed in the appendices attached to this specification.

2.1.1 Deviations from the Generic Specification

None.

2.2 MARKING

The marking shall be in accordance with the requirements of ESCC Basic Specification No. 21700 and as follows.

The information to be marked on the component shall be:

- (a) Terminal identification (see Para. 1.7).
- (b) The ESCC qualified components symbol (for ESCC qualified components only).
- (c) The ESCC Component Number (see Para. 1.4.1).
- (d) Traceability information.

2.3 ELECTRICAL MEASUREMENTS AT ROOM, HIGH AND LOW TEMPERATURES

Electrical measurements shall be performed at room, high and low temperatures. Consolidated Notes are given in Para. 2.3.3.

2.3.1 Room Temperature Electrical Measurements

The measurements shall be performed at $T_{amb} = +22 \pm 3^{\circ}C$.

Characteristics	Symbols	MIL-STD-883 Test Method	Test Conditions Note 1	Limits		Units
				Min	Max	
Functional Test 1	-	3014	Verify Truth Table without Load $V_{IL} = 0.3V, V_{IH} = 1.5V$ $V_{DD} = 2V, V_{SS} = 0V$ $t_r < 1\mu s$ Note 2	-	-	-
Functional Test 2	-	3014	Verify Truth Table without Load $V_{IL} = 0.9V, V_{IH} = 3.15V$ $V_{DD} = 4.5V, V_{SS} = 0V$ $t_r = t_f < 500ns$ Note 2	-	-	-

Characteristics	Symbols	MIL-STD-883 Test Method	Test Conditions Note 1	Limits		Units
				Min	Max	
Functional Test 3	-	3014	Verify Truth Table without Load $V_{IL} = 1.2V, V_{IH} = 4.2V$ $V_{DD} = 6V, V_{SS} = 0V$ $t_r = t_f < 400ns$ Note 2	-	-	-
Quiescent Current	I_{DD}	3005	$V_{IL} = 0V, V_{IH} = 6V$ $V_{DD} = 6V, V_{SS} = 0V$ All Outputs Open Note 3	-	400	nA
Low Level Input Current	I_{IL}	3009	$V_{IN} \text{ (Under Test)} = 0V$ $V_{IN} \text{ (Remaining Inputs)}$ $= 6V$ $V_{DD} = 6V, V_{SS} = 0V$	-	-50	nA
High Level Input Current	I_{IH}	3010	$V_{IN} \text{ (Under Test)} = 6V$ $V_{IN} \text{ (Remaining Inputs)}$ $= 0V$ $V_{DD} = 6V, V_{SS} = 0V$	-	50	nA
Low Level Output Voltage 1	V_{OL1}	3007	$V_{IL} = 0.3V, V_{IH} = 1.5V,$ $I_{OL} = 20\mu A$ $V_{DD} = 2V, V_{SS} = 0V$	-	100	mV
Low Level Output Voltage 2	V_{OL2}	3007	$V_{IL} = 0.9V, V_{IH} = 3.15V,$ $I_{OL} = 20\mu A$ $V_{DD} = 4.5V, V_{SS} = 0V$	-	100	mV
Low Level Output Voltage 3	V_{OL3}	3007	$V_{IL} = 1.2V, V_{IH} = 4.2V,$ $I_{OL} = 20\mu A$ $V_{DD} = 6V, V_{SS} = 0V$	-	100	mV
Low Level Output Voltage 4	V_{OL4}	3007	$V_{IL} = 0.9V, V_{IH} = 3.15V,$ $I_{OL} = 6mA$ $V_{DD} = 4.5V, V_{SS} = 0V$	-	260	mV
Low Level Output Voltage 5	V_{OL5}	3007	$V_{IL} = 1.2V, V_{IH} = 4.2V,$ $I_{OL} = 7.8mA$ $V_{DD} = 6V, V_{SS} = 0V$	-	260	mV
High Level Output Voltage 1	V_{OH1}	3006	$V_{IL} = 0.3V, V_{IH} = 1.5V,$ $I_{OH} = -20\mu A$ $V_{DD} = 2V, V_{SS} = 0V$	1.9	-	V
High Level Output Voltage 2	V_{OH2}	3006	$V_{IL} = 0.9V, V_{IH} = 3.15V,$ $I_{OH} = -20\mu A$ $V_{DD} = 4.5V, V_{SS} = 0V$	4.4	-	V
High Level Output Voltage 3	V_{OH3}	3006	$V_{IL} = 1.2V, V_{IH} = 4.2V,$ $I_{OH} = -20\mu A$ $V_{DD} = 6V, V_{SS} = 0V$	5.9	-	V

Characteristics	Symbols	MIL-STD-883 Test Method	Test Conditions Note 1	Limits		Units
				Min	Max	
High Level Output Voltage 4	V _{OH4}	3006	V _{IL} = 0.9V, V _{IH} = 3.15V, I _{OH} = -6mA V _{DD} = 4.5V, V _{SS} = 0V	3.98	-	V
High Level Output Voltage 5	V _{OH5}	3006	V _{IL} = 1.2V, V _{IH} = 4.2V, I _{OH} = -7.8mA V _{DD} = 6V, V _{SS} = 0V	5.48	-	V
Threshold Voltage N-Channel	V _{THN}	-	DIR, \bar{G} Inputs at Ground B Data Inputs: V _{IN} = 5V V _{DD} = 5V, I _{SS} = -10 μ A	-0.45	-1.45	V
Threshold Voltage P-Channel	V _{THP}	-	DIR Input at Ground A Data, \bar{G} Inputs: V _{IN} = -5V V _{SS} = -5V, I _{DD} = 10 μ A	0.45	1.35	V
Input Clamp Voltage 1, to V _{SS}	V _{IC1}	-	I _{IN} (Under Test) = -100 μ A V _{DD} = Open, V _{SS} = 0V All Other Pins Open DIR, \bar{G} Inputs A Data, B Data Inputs	-400 -0.25	-900 -1.2	mV V
Input Clamp Voltage 2, to V _{DD}	V _{IC2}	-	I _{IN} (Under Test) = 100 μ A V _{DD} = 0V, V _{SS} = Open All Other Pins Open DIR, \bar{G} Inputs A Data, B Data Inputs	400 0.25	900 1.2	mV V
Output Leakage Current Third State, Low Level Applied	I _{OZL}	3020	V _{IN} (\bar{G}) = 6V V _{IN} (Remaining Inputs) = 0V V _{OUT} = 0V V _{DD} = 6V, V _{SS} = 0V	-	-500	nA
Output Leakage Current Third State, High Level Applied	I _{OZH}	3021	V _{IN} (\bar{G}) = 6V V _{IN} (Remaining Inputs) = 0V V _{OUT} = 6V V _{DD} = 6V, V _{SS} = 0V	-	500	nA
Input Capacitance	C _{IN}	3012	V _{IN} (Not Under Test) = 0V V _{DD} = V _{SS} = 0V f = 100kHz to 1MHz Note 4	-	10	pF

Characteristics	Symbols	MIL-STD-883 Test Method	Test Conditions Note 1	Limits		Units
				Min	Max	
Propagation Delay Low to High, A1 to B1 B2 to A2	t _{PLH}	3003	V _{IN} (Under Test) = Pulse Generator V _{IN} (Remaining Inputs) = Truth Table V _{IL} = 0V, V _{IH} = 4.5V V _{DD} = 4.5V, V _{SS} = 0V Note 5	-	27	ns
Propagation Delay High to Low, A1 to B1 B2 to A2	t _{PHL}	3003	V _{IN} (Under Test) = Pulse Generator V _{IN} (Remaining Inputs) = Truth Table V _{IL} = 0V, V _{IH} = 4.5V V _{DD} = 4.5V, V _{SS} = 0V Note 5	-	27	ns
Transition Time Low to High A8, B1	t _{TLH}	3004	V _{IN} (Under Test) = Pulse Generator V _{IN} (Remaining Inputs) = Truth Table V _{IL} = 0V, V _{IH} = 4.5V V _{DD} = 4.5V, V _{SS} = 0V Note 5	-	12	ns
Transition Time High to Low A8, B1	t _{THL}	3004	V _{IN} (Under Test) = Pulse Generator V _{IN} (Remaining Inputs) = Truth Table V _{IL} = 0V, V _{IH} = 4.5V V _{DD} = 4.5V, V _{SS} = 0V Note 5	-	12	ns
Output Enable Time High Impedance to Low Output, \bar{G} to B1 \bar{G} to A8	t _{PZL}	3003	V _{IN} (Under Test) = Pulse Generator V _{IN} (Remaining Inputs) = Truth Table V _{IL} = 0V, V _{IH} = 4.5V V _{DD} = 4.5V, V _{SS} = 0V Note 5	-	46	ns
Output Enable Time High Impedance to High Output, \bar{G} to B1 \bar{G} to A8	t _{PZH}	3003	V _{IN} (Under Test) = Pulse Generator V _{IN} (Remaining Inputs) = Truth Table V _{IL} = 0V, V _{IH} = 4.5V V _{DD} = 4.5V, V _{SS} = 0V Note 5	-	46	ns

Characteristics	Symbols	MIL-STD-883 Test Method	Test Conditions Note 1	Limits		Units
				Min	Max	
Output Disable Time Low Output to High Impedance, \bar{G} to B1 \bar{G} to A8	t _{PLZ}	3003	V _{IN} (Under Test) = Pulse Generator V _{IN} (Remaining Inputs) = Truth Table V _{IL} = 0V, V _{IH} = 4.5V V _{DD} = 4.5V, V _{SS} = 0V Note 5	-	40	ns
Output Disable Time High Output to High Impedance, \bar{G} to B1 \bar{G} to A8	t _{PHZ}	3003	V _{IN} (Under Test) = Pulse Generator V _{IN} (Remaining Inputs) = Truth Table V _{IL} = 0V, V _{IH} = 4.5V V _{DD} = 4.5V, V _{SS} = 0V Note 5	-	40	ns

2.3.2 High and Low Temperatures Electrical Measurements

The measurements shall be performed at T_{amb} = +125 (+0 -5)°C and T_{amb} = -55 (+5 -0)°C.

Characteristics	Symbols	MIL-STD-883 Test Method	Test Conditions Note 1	Limits		Units
				Min	Max	
Functional Test 1	-	3014	Verify Truth Table without Load V _{IL} = 0.3V, V _{IH} = 1.5V V _{DD} = 2V, V _{SS} = 0V t _r < 1μs Note 2	-	-	-
Functional Test 2	-	3014	Verify Truth Table without Load V _{IL} = 0.9V, V _{IH} = 3.15V V _{DD} = 4.5V, V _{SS} = 0V t _r = t _f < 500ns Note 2	-	-	-
Functional Test 3	-	3014	Verify Truth Table without Load V _{IL} = 1.2V, V _{IH} = 4.2V V _{DD} = 6V, V _{SS} = 0V t _r = t _f < 400ns Note 2	-	-	-
Quiescent Current	I _{DD}	3005	V _{IL} = 0V, V _{IH} = 6V V _{DD} = 6V, V _{SS} = 0V All Outputs Open Note 3	-	8	μA

Characteristics	Symbols	MIL-STD-883 Test Method	Test Conditions Note 1	Limits		Units
				Min	Max	
Low Level Input Current	I_{IL}	3009	V_{IN} (Under Test) = 0V V_{IN} (Remaining Inputs) = 6V $V_{DD} = 6V, V_{SS} = 0V$	-	-1	μA
High Level Input Current	I_{IH}	3010	V_{IN} (Under Test) = 6V V_{IN} (Remaining Inputs) = 0V $V_{DD} = 6V, V_{SS} = 0V$	-	1	μA
Low Level Output Voltage 1	V_{OL1}	3007	$V_{IL} = 0.3V, V_{IH} = 1.5V,$ $I_{OL} = 20\mu A$ $V_{DD} = 2V, V_{SS} = 0V$	-	100	mV
Low Level Output Voltage 2	V_{OL2}	3007	$V_{IL} = 0.9V, V_{IH} = 3.15V,$ $I_{OL} = 20\mu A$ $V_{DD} = 4.5V, V_{SS} = 0V$	-	100	mV
Low Level Output Voltage 3	V_{OL3}	3007	$V_{IL} = 1.2V, V_{IH} = 4.2V,$ $I_{OL} = 20\mu A$ $V_{DD} = 6V, V_{SS} = 0V$	-	100	mV
Low Level Output Voltage 4	V_{OL4}	3007	$V_{IL} = 0.9V, V_{IH} = 3.15V,$ $I_{OL} = 6mA$ $V_{DD} = 4.5V, V_{SS} = 0V$	-	400	mV
Low Level Output Voltage 5	V_{OL5}	3007	$V_{IL} = 1.2V, V_{IH} = 4.2V,$ $I_{OL} = 7.8mA$ $V_{DD} = 6V, V_{SS} = 0V$	-	400	mV
High Level Output Voltage 1	V_{OH1}	3006	$V_{IL} = 0.3V, V_{IH} = 1.5V,$ $I_{OH} = -20\mu A$ $V_{DD} = 2V, V_{SS} = 0V$	1.9	-	V
High Level Output Voltage 2	V_{OH2}	3006	$V_{IL} = 0.9V, V_{IH} = 3.15V,$ $I_{OH} = -20\mu A$ $V_{DD} = 4.5V, V_{SS} = 0V$	4.4	-	V
High Level Output Voltage 3	V_{OH3}	3006	$V_{IL} = 1.2V, V_{IH} = 4.2V,$ $I_{OH} = -20\mu A$ $V_{DD} = 6V, V_{SS} = 0V$	5.9	-	V
High Level Output Voltage 4	V_{OH4}	3006	$V_{IL} = 0.9V, V_{IH} = 3.15V,$ $I_{OH} = -6mA$ $V_{DD} = 4.5V, V_{SS} = 0V$	3.7	-	V
High Level Output Voltage 5	V_{OH5}	3006	$V_{IL} = 1.2V, V_{IH} = 4.2V,$ $I_{OH} = -7.8mA$ $V_{DD} = 6V, V_{SS} = 0V$	5.2	-	V

Characteristics	Symbols	MIL-STD-883 Test Method	Test Conditions Note 1	Limits		Units
				Min	Max	
Input Clamp Voltage 1, to V_{SS}	V_{IC1}	-	I_{IN} (Under Test) = $-100\mu A$ V_{DD} = Open, V_{SS} = 0V All Other Pins Open DIR, \bar{G} Inputs A Data, B Data Inputs	-0.1 -0.25	-1.2 -1.2	V V
Input Clamp Voltage 2, to V_{DD}	V_{IC2}	-	I_{IN} (Under Test) = $100\mu A$ V_{DD} = 0V, V_{SS} = Open All Other Pins Open DIR, \bar{G} Inputs A Data, B Data Inputs	0.1 0.25	1.2 1.2	V V
Output Leakage Current Third State, Low Level Applied	I_{OZL}	3020	$V_{IN}(\bar{G})$ = 6V V_{IN} (Remaining Inputs) = 0V V_{OUT} = 0V V_{DD} = 6V, V_{SS} = 0V	-	-10	μA
Output Leakage Current Third State, High Level Applied	I_{OZH}	3021	$V_{IN}(\bar{G})$ = 6V V_{IN} (Remaining Inputs) = 0V V_{OUT} = 6V V_{DD} = 6V, V_{SS} = 0V	-	10	μA

2.3.3 Notes to Electrical Measurement Tables

1. Unless otherwise specified all inputs and outputs shall be tested for each characteristic, inputs not under test shall be $V_{IN} = V_{SS}$ or V_{DD} and outputs not under test shall be open.
2. Functional tests shall be performed with $f = 10\text{kHz}$ (min). The maximum time to output comparator strobe = $30\mu\text{s}$.
3. Quiescent Current shall be tested using the following input conditions:
 - (a) $\overline{G} = B2 = B4 = B6 = B8 = V_{IL}$; $B1 = B3 = B5 = B7 = V_{IH}$
 - (b) $\overline{G} = V_{IL}$; B Data Inputs = V_{IH}
 - (c) $\overline{G} = A1 = A3 = A5 = A7 = V_{IL}$; $\text{DIR} = A2 = A4 = A6 = A8 = V_{IH}$
 - (d) $\overline{G} = V_{IL}$; DIR = A Data Inputs = V_{IH}
 - (e) $\text{DIR} = A8 = V_{IL}$; $\overline{G} = A1 = A2 = A3 = A4 = A5 = A6 = A7 = \text{B Data Inputs} = V_{IH}$
 - (f) $\text{DIR} = \text{A Data Inputs} = \text{B Data Inputs} = V_{IL}$; $\overline{G} = V_{IH}$
4. Guaranteed but not tested.
5. Measurements shall be performed as a go-no-go test on a 100% basis. Read and record measurements shall be performed on a sample of 5 components.

The pulse generator shall have the following characteristics:

$V_{GEN} = 0$ to V_{DD} ; $f_{GEN} = 1\text{MHz}$ minimum; t_r and $t_f \leq 6\text{ns}$ (10% to 90%); duty cycle = 50%; $Z_{out} = 50\Omega$. Output load capacitance $C_L = 50\text{pF} \pm 5\%$ including scope probe, wiring and stray capacitance without component in the test fixture and output load resistance $R_L = 1\text{k}\Omega \pm 5\%$.

Propagation delay and transition time shall be measured as follows:

PARAMETER	R_L	C_L	S1	S2
t_{PZH}	1k Ω	50pF	OPEN	CLOSED
t_{PZL}			CLOSED	OPEN
t_{PHZ}	1k Ω	50pF	OPEN	CLOSED
t_{PLZ}			CLOSED	OPEN
$t_{PHL}, t_{PLH}, t_{THL}, t_{TLH}$	-	50pF	OPEN	OPEN

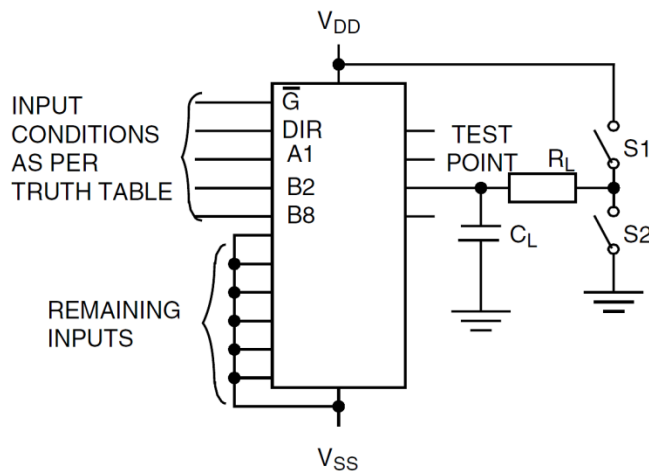

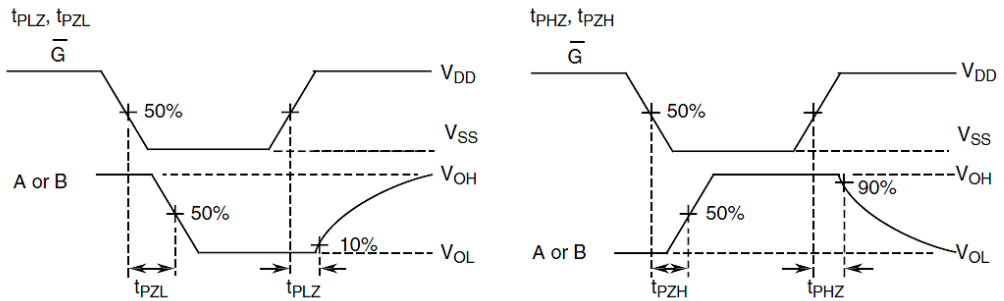
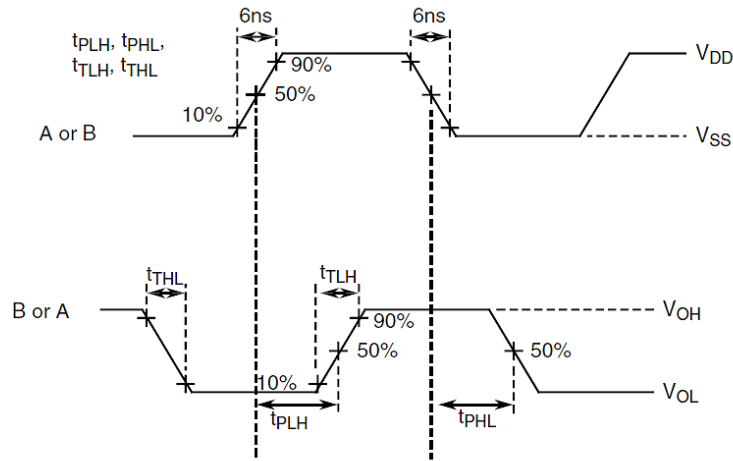

2.4 PARAMETER DRIFT VALUES

Unless otherwise specified, the measurements shall be performed at $T_{amb} = +22 \pm 3^{\circ}C$.

The test methods and test conditions shall be as per the corresponding test defined in Para. 2.3.1 Room Temperature Electrical Measurements.

The drift values (Δ) shall not be exceeded for each characteristic specified. The corresponding absolute limit values for each characteristic shall not be exceeded.

Characteristics	Symbols	Limits			Units
		Drift Value Δ	Absolute		
			Min	Max	
Quiescent Current	I_{DD}	± 120	-	400	nA
Low Level Input Current	I_{IL}	± 20	-	-50	nA
High Level Input Current	I_{IH}	± 20	-	50	nA
Low Level Output Voltage 4	V_{OL4}	± 26	-	260	mV
High Level Output Voltage 4	V_{OH4}	± 0.2	3.98	-	V
Threshold Voltage N-Channel	V_{THN}	± 0.3	-0.45	-1.45	V
Threshold Voltage P-Channel	V_{THP}	± 0.3	0.45	1.35	V

NOTES:

1. Unless otherwise specified all inputs and outputs shall be tested for each characteristic.

2.5 INTERMEDIATE AND END-POINT ELECTRICAL MEASUREMENTS

Unless otherwise specified, the measurements shall be performed at $T_{amb} = +22 \pm 3^{\circ}C$.

The test methods and test conditions shall be as per the corresponding test defined in Para. 2.3.1 Room Temperature Electrical Measurements.

The drift values (Δ) shall not be exceeded for each characteristic where specified. The corresponding absolute limit values for each characteristic shall not be exceeded.

Characteristics	Symbols	Limits			Units
		Drift Value Δ	Absolute		
			Min	Max	
Functional Test 1	-	-	-	-	-
Functional Test 2	-	-	-	-	-
Functional Test 3	-	-	-	-	-
Quiescent Current	I_{DD}	± 120	-	400	nA
Low Level Input Current	I_{IL}	± 20	-	-50	nA
High Level Input Current	I_{IH}	± 20	-	50	nA
Low Level Output Voltage 4	V_{OL4}	± 26	-	260	mV
Low Level Output Voltage 5	V_{OL5}	± 26	-	260	mV
High Level Output Voltage 4	V_{OH4}	± 0.2	3.98	-	V
High Level Output Voltage 5	V_{OH5}	± 0.2	5.48	-	V
Threshold Voltage N-Channel	V_{THN}	± 0.3	-0.45	-1.45	V
Threshold Voltage P-Channel	V_{THP}	± 0.3	0.45	1.35	V
Output Leakage Current Third State, Low Level Applied	I_{OZL}	± 200	-	-500	nA
Output Leakage Current Third State, High Level Applied	I_{OZH}	± 200	-	500	nA

NOTES:

1. Unless otherwise specified all inputs and outputs shall be tested for each characteristic.
2. The drift values (Δ) are applicable to the Operating Life test only.

2.6 HIGH TEMPERATURE REVERSE BIAS BURN-IN CONDITIONS

2.6.1 N-Channel HTRB

Characteristics	Symbols	Test Conditions	Units
Ambient Temperature	T _{amb}	+125 (+0 -5)	°C
Outputs A Bus	V _{OUT}	Open or V _{SS}	V
Inputs DIR, \bar{G} , B Data	V _{IN}	V _{SS}	V
Positive Supply Voltage	V _{DD}	6 (+0 -0.5)	V
Negative Supply Voltage	V _{SS}	0	V
Duration	t	72	Hours

NOTES:

1. Input Protection Resistor = 680Ω min to 47kΩ max.
2. Output Load = 1kΩ min to 10kΩ max.

2.6.2 P-Channel HTRB

Characteristics	Symbols	Test Conditions	Units
Ambient Temperature	T _{amb}	+125 (+0 -5)	°C
Outputs A Bus	V _{OUT}	Open or V _{DD}	V
Inputs DIR, \bar{G} , B Data	V _{IN}	V _{DD}	V
Positive Supply Voltage	V _{DD}	6 (+0 -0.5)	V
Negative Supply Voltage	V _{SS}	0	V
Duration	t	72	Hours

NOTES:

1. Input Protection Resistor = 680Ω min to 47kΩ max.
2. Output Load = 1kΩ min to 10kΩ max.

2.7 POWER BURN-IN CONDITIONS

Characteristics	Symbols	Test Conditions	Units
Ambient Temperature	T _{amb}	+125 (+0 -5)	°C
Outputs B Bus	V _{OUT}	V _{DD}	V
Input \bar{G}	V _{IN}	V _{SS}	V
Input DIR	V _{IN}	V _{DD}	V
Inputs A Data	V _{IN}	V _{GEN}	V
Pulse Voltage	V _{GEN}	0V to V _{DD}	V
Pulse Frequency Square Wave	f _{GEN}	100k ±10% 50 ±15% Duty Cycle t _r = t _f ≤ 400ns	Hz
Positive Supply Voltage	V _{DD}	6 (+0 -0.5)	V
Negative Supply Voltage	V _{SS}	0	V

NOTES:

1. Input Protection Resistor = 680Ω min to 47kΩ max.
2. Output Load = 1kΩ min to 10kΩ max.

2.8 OPERATING LIFE CONDITIONS

The conditions shall be as specified for Para. 2.7 Power Burn-in.

2.9 TOTAL DOSE RADIATION TESTING

2.9.1 Bias Conditions and Total Dose Level for Total Dose Radiation Testing

Continuous bias shall be applied during irradiation testing as specified below.

The total dose level applied shall be as specified in Para. 1.4.2 or in the Purchase Order.

Characteristics	Symbols	Test Conditions	Units
Ambient Temperature	T _{amb}	+22 ±3	°C
Outputs B Bus	V _{OUT}	Open	V
Input DIR	V _{IN}	V _{DD}	V
Inputs \bar{G} , A Data	V _{IN}	V _{SS}	V
Positive Supply Voltage	V _{DD}	6 ±0.3	V
Negative Supply Voltage	V _{SS}	0	V

NOTES:

1. Input Protection Resistor = 680Ω min to 47kΩ max.

2.9.2 Electrical Measurements for Total Dose Radiation Testing

Prior to irradiation testing the devices shall have successfully met Para. 2.3.1 Room Temperature Electrical Measurements specified herein.

Unless otherwise stated the measurements shall be performed at T_{amb} = +22 ±3°C.

The test methods and test conditions shall be as per the corresponding test defined in Para. 2.3.1 Room Temperature Electrical Measurements.

The parameters to be measured during and on completion of irradiation testing are shown below.

Unless otherwise specified all inputs and outputs shall be tested for each characteristic.

Characteristics	Symbols	Limits			Units
		Drift Value Δ	Absolute		
			Min	Max	
Quiescent Current	I _{DD}	-	-	40	μA
Threshold Voltage N-Channel	V _{THN}	±0.6	-0.2	-1.5	V
Threshold Voltage P-Channel	V _{THP}	±0.6	0.7	2.2	V

APPENDIX 'A'
AGREED DEVIATIONS FOR STMICROELECTRONICS (F)

ITEMS AFFECTED	DESCRIPTION OF DEVIATIONS
Para. 2.1.1 Deviations from the Generic Specification: Deviations from Production Control - Chart F2	<p>Total Dose Radiation Testing: The following deviation from the procedures for qualification and procurement lot acceptance in ESCC Basic Specification No. 22900 shall apply:</p> <p>The radiation exposure and test sequence requirements including radiation levels, time intervals for measurement, and the flow chart for qualification and lot acceptance testing, may be replaced by the requirements of ST radiation test procedure 0043082.</p>
Para. 2.1.1 Deviations from the Generic Specification: Deviations from Screening Tests - Chart F3	<p>External Visual Inspection: The criteria applicable to chip-outs are those described in MIL-STD-883, Test Method 2009, Paras 3.3.6(b) and 3.3.7(a).</p> <p>High Temperature Reverse Bias Burn-in: The temperature limits of MIL-STD-883, Para. 4.5.8(c) may be used.</p> <p>Power Burn-in test is performed using STMicroelectronics Specification Ref: 0019255.</p> <p>Solderability is not applicable unless specifically stipulated in the Purchase Order.</p>
Para. 2.1.1 Deviations from the Generic Specification: Deviations from Qualification and Periodic Tests - Chart F4	<p>External Visual Inspection: The criteria applicable to chip-outs are those described in MIL-STD-883, Test Method 2009, Paras 3.3.6(b) and 3.3.7(a).</p> <p>Operating Life: The temperature limits of MIL-STD-883, Para. 4.5.8(c) may be used.</p>
Para. 2.3.1 Room Temperature Electrical Measurements	<p>All AC characteristics (Capacitance and Timings) may be considered guaranteed but not tested if successful pilot lot testing has been performed on the wafer lot which includes AC characteristic measurements per the Detail Specification.</p> <p>A summary of the pilot lot testing shall be provided if required by the Purchase Order.</p>
Para. 2.3.2 High and Low Temperatures Electrical Measurements	<p>High and Low Temperatures Electrical Measurements may be considered guaranteed but not tested if successful pilot lot testing has been performed on the wafer lot which includes High and Low Temperatures Electrical Measurements per the Detail Specification.</p> <p>A summary of the pilot lot testing shall be provided if required by the Purchase Order.</p>