



## **EXTERNAL VISUAL INSPECTION OF FLEXIBLE HEATERS**

**ESCC Basic Specification No. 2054009**

Issue 4	May 2019
---------	----------



**LEGAL DISCLAIMER AND COPYRIGHT**

European Space Agency, Copyright © 2019. All rights reserved.

The European Space Agency disclaims any liability or responsibility, to any person or entity, with respect to any loss or damage caused, or alleged to be caused, directly or indirectly by the use and application of this ESCC publication.

This publication, without the prior permission of the European Space Agency and provided that it is not used for a commercial purpose, may be:

- copied in whole, in any medium, without alteration or modification.
- copied in part, in any medium, provided that the ESCC document identification, comprising the ESCC symbol, document number and document issue, is removed.

**DOCUMENTATION CHANGE NOTICE**

(Refer to <https://escies.org> for ESCC DCR content)

DCR No.	CHANGE DESCRIPTION
<a href="#">1207</a>	Specification upissued to incorporate changes per DCRs.

**TABLE OF CONTENTS**

1	SCOPE	6
2	GENERAL REQUIREMENTS	6
2.1	APPLICABILITY	6
2.2	PROCEDURE	6
2.3	MAGNIFICATION	6
2.4	MOUNTING FIXTURES	6
2.5	ILLUMINATION	6
3	TERMS AND DEFINITIONS	7
4	DETAILED REQUIREMENTS	7
4.1	GENERAL	7
4.2	DIMENSIONS AND MARKING	7
4.3	MATERIALS	8
4.4	LEADWIRES	8
4.4.1	Flattened Wire	8
4.4.2	Integrity	9
4.5	WELDED LEAD CONNECTIONS	9
4.5.1	Location of Lead Wire	9
4.5.2	Visual Aspect	10
4.5.3	Weld Window (if applicable)	11
4.6	CONDUCTOR ETCHING	12
4.6.1	General	12
4.6.2	Nicks and Protrusions	13
4.6.3	Metallic Islets and Inclusions	14
4.6.4	Lack of Metal	15
4.6.5	Other Random Defects	15
4.7	DEFORMATION	16
4.7.1	Folds	16
4.7.2	Slips	18
4.7.3	Local Deformation	19
4.8	BLISTERING AND DELAMINATION	20
4.8.1	Track Unsticking	20
4.8.2	Delamination	21
4.9	RAGGED EDGES	22
4.10	ASPECT DEFECTS	23
4.10.1	Spots	23
4.10.2	Bubbles	24



4.10.3	Surface Scratches	25
4.10.4	Non-Metallic Inclusions	26
4.11	MISREGISTRATION	27

## 1 **SCOPE**

This specification, to be read in conjunction with ESCC Basic Specification No. [20500](#), External Visual Inspection, contains additional requirements for Flexible Heaters.

They shall apply, where relevant, to each component inspected.

## 2 **GENERAL REQUIREMENTS**

### 2.1 **APPLICABILITY**

The following criteria may not be varied or modified after commencing any inspection stage. Any ambiguity or proposed minor deviation shall be referred to the ESCC Executive for resolution and approval.

### 2.2 **PROCEDURE**

All items shall be examined in such a manner that a minimum of handling and movement of the component is involved. During handling of components, lint free gloves/finger cots shall be used.

### 2.3 **MAGNIFICATION**

All items shall be examined with a binocular or stereoscopic microscope under a magnification of between 2X and 15X depending upon track width.

### 2.4 **MOUNTING FIXTURES**

Suitable fixtures may be used to assist in the inspection process provided they do not of themselves cause damage to the device.

### 2.5 **ILLUMINATION**

The samples are illuminated in such a manner that all aspect defects listed below will be revealed.

### 3 TERMS AND DEFINITIONS

<b>Blister</b>	- Delamination in the form of a localised swelling and separation between base material and conductive foil or coverlay.
<b>Bubble</b>	- An entrapment of air or gas in a protective coating.
<b>Deformation</b>	- All metallic foil defects such as dents, folds, bumps and blisters.
<b>Delamination</b>	- A separation between base material and conductive foil.
<b>Flattened wire</b>	- A wire become flat during pressing operations.
<b>Inclusions</b>	- Foreign particles, metallic or non-metallic, entrapped in an insulating material.
<b>Metallic islet</b>	- An unetched little metallic area reducing insulation between two tracks.
<b>Misregistration</b>	- Imperfect registration.
<b>Nick</b>	- A cut in the edge of a track.
<b>Notch</b>	- A cut in the wire insulation.
<b>Pad</b>	- The metallic extension where wire is welded.
<b>Paving-block</b>	- Insulating pavement making encapsulation of wires.
<b>Pinhole</b>	- An imperfection in the form of a small hole that penetrates entirely through the layer of metal.
<b>Protrusion</b>	- Metallic protuberance in the edge of a track.
<b>Ragged edge</b>	- Edge with tears, impacts, notches or other damage.
<b>Scratch</b>	- A narrow furrow or groove in a surface.
<b>Slip</b>	- Slipping of tracks during coverlay lamination cycle.
<b>Spot</b>	- A blot on a metallic surface or in an insulating material.

### 4 DETAILED REQUIREMENTS

#### 4.1 GENERAL

A component shall be rejected if it exhibits one or more of the defects listed in any of the following paragraphs. Where applicable, drawings are included to provide additional explanatory material.

The external visual inspection includes the verification of:

- Dimensions.
- Marking.
- Materials.
- Mechanical defects.

#### 4.2 DIMENSIONS AND MARKING

Dimensions and marking shall be inspected in accordance with the requirements of ESCC Basic Specification No. [20500](#), Paras. 4.6 and 4.7.

All letters and numbers shall be clearly legible without the use of optical resources.

Dimensional tolerances shall be as specified in the relevant ESCC Detail Specification.

#### 4.3 MATERIALS

The materials used shall be verified for conformance to the requirements of the applicable ESCC Detail Specification.

The production records shall be checked to ensure that the specified material requirements are met.

#### 4.4 LEADWIRES

##### 4.4.1 Flattened Wire

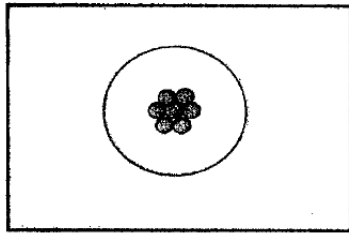

#### GOOD

Wire is intact.

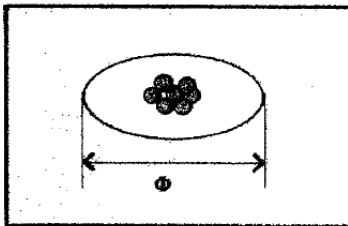

#### ACCEPTABLE

Wire is slightly flattened.

Rule:  $\phi \leq 1.4 \times \text{Nominal diameter}$ .

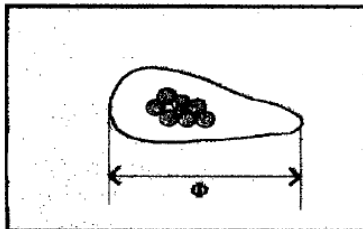

#### REJECTED

Wire is flattened.

Rule:  $\phi > 1.4 \times \text{Nominal diameter}$ .



4.4.2 Integrity  
Notches and scratches on wire insulation.

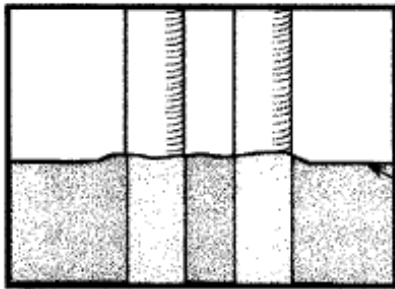

**GOOD**  
Wire is intact.  
No visible defect, without the use of optical resources.

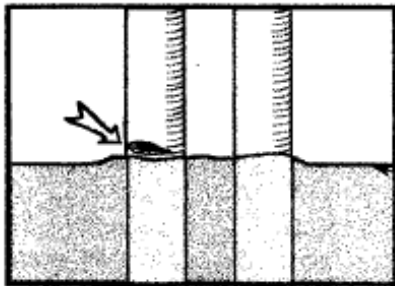

**REJECTED**  
Visible defects on the wire insulation:  
- Deep scratch or notch.  
- Slight cut.

4.5 WELDED LEAD CONNECTIONS

4.5.1 Location of Lead Wire

(a) Position in relation to heater edge.

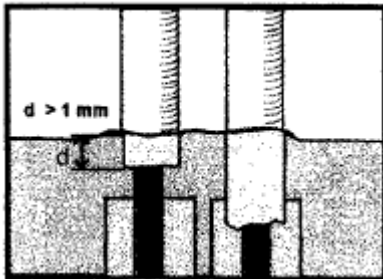

**GOOD**  
The wire insulation penetration under the Kapton is equal to or greater than 1mm.

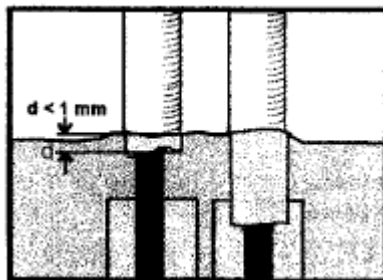

**REJECTED**  
The wire insulation penetration under the Kapton is less than 1mm.

(b) Wire position on connection pad.

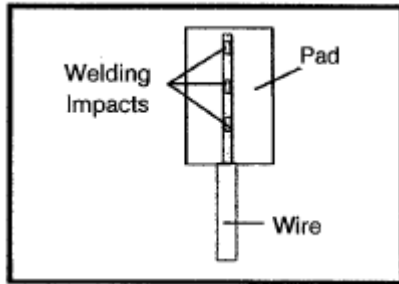

**GOOD**

The wire is well centred.

The wire is right or slightly bowed.

Twist is regular, strands are well joined (see also Para. 4.4.1).

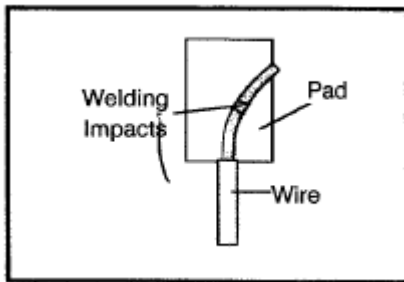

**REJECTED**

Wire outside pad.

Welding impacts are insufficient (< 2).

4.5.2 Visual Aspect

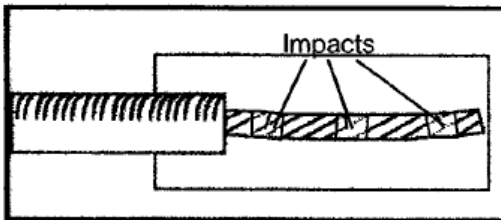

**GOOD**

No discoloration on the welding area.

No broken strands.

No free element (detached or projecting).

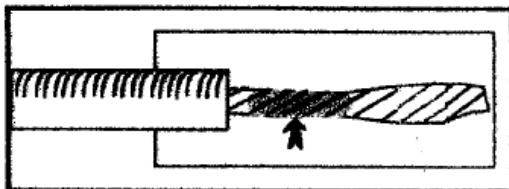

**REJECTED**

Discoloration of the welding area.

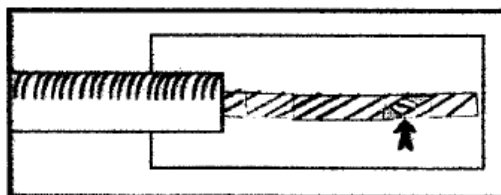

**REJECTED**

Broken strand.

4.5.3 Weld Window (if applicable)

(a) Examination of weld window itself and its environment.

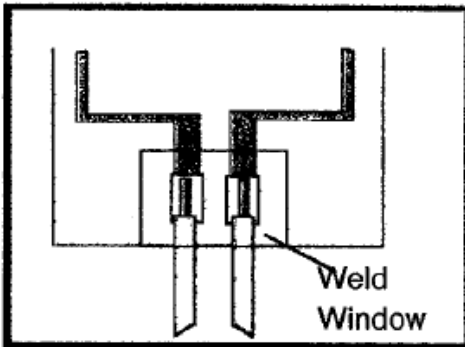

**GOOD**

No unsticking.

No adhesive flow.

Good position. In particular the Kapton pad covers the opening of the upper coverlay for double-sided heaters.

No bubbles in the adhesive.

Good wire encapsulation (no void at the end of the sheath next to bare areas).

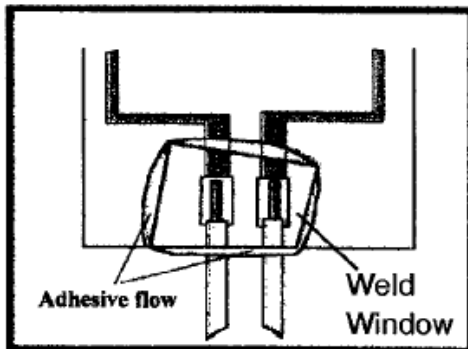

**ACCEPTABLE**

Adhesive flow next to wires  $\geq 2\text{mm}$ .

Crosswise position but wire encapsulation is correct.

**N.B.**

Removal of excess adhesive with scalpel is not allowed.

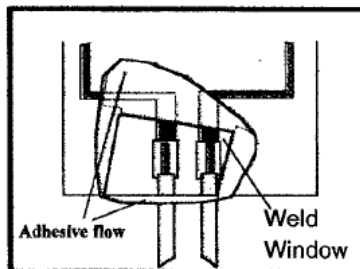

**REJECTED**

Excessive adhesive flow  $\geq 2\text{mm}$  next to wires. Bad wire encapsulation.

Local unsticking.

Bad coverage of the opening of the upper coverlay for double-sided heaters.

**N.B.**

Removal of excess adhesive with scalpel is not allowed.

4.6 CONDUCTOR ETCHING

4.6.1 General

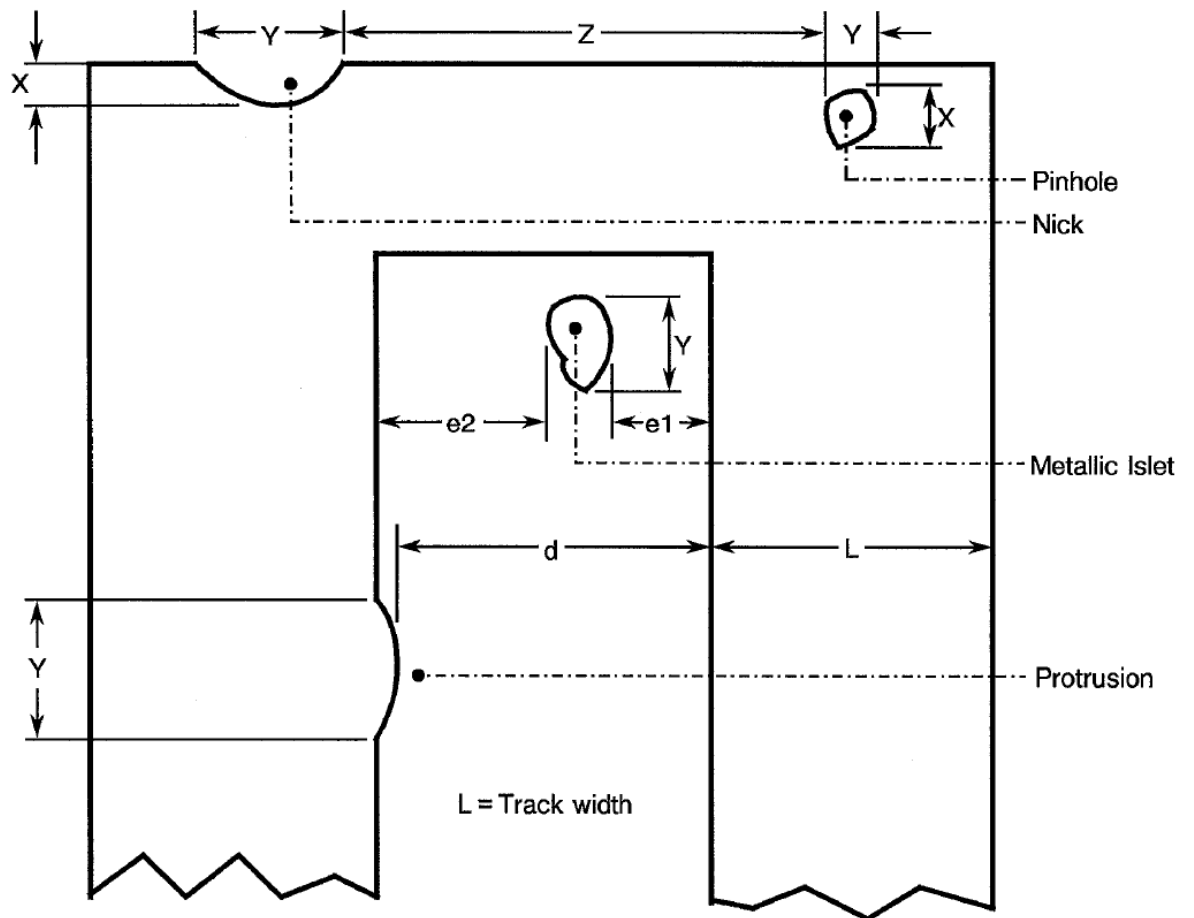

4.6.2 Nicks and Protrusions

**Distance between tracks  $\leq 0.8\text{mm}$ :**

- (a)  $X \leq 30\%$  of L.
- (b)  $Y \leq 0.5\text{mm}$ .
- (c) Z: Minimum space between two defects = 5mm.
- (d)  $d \geq 0.05\text{mm}$ .

**Distance between tracks  $> 0.8\text{mm}$ :**

- (a)  $X \leq 25\%$  of L.
- (b)  $Y \leq 1\text{mm}$ .
- (c) Z: Minimum space between two defects = 1.5mm.
- (d)  $d \geq 0.05\text{mm}$ .

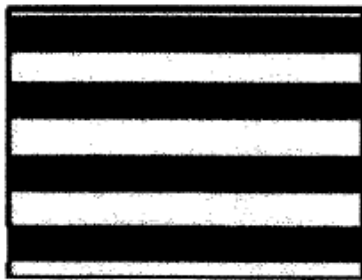

**GOOD**  
No visual defects.

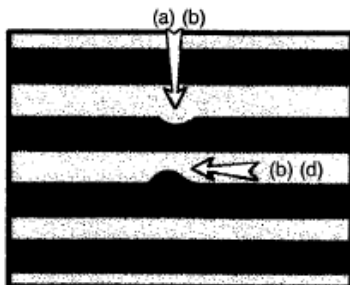

**ACCEPTABLE**  
Track width reduction (a) and length of defect (b) are less than permitted limits.  
Distance between tracks (d) is greater than 0.05mm and length of defect (b) is less than permitted limits.

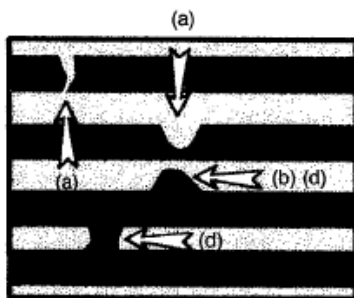

**REJECTED**  
Track width reduction (a) or length of defect is more than permitted limits.  
Cut track (a).  
Distance between tracks (d) is less than permitted limits or length defect (b) is more than permitted limits.  
Short circuit between tracks (d).

4.6.3 Metallic Islets and Inclusions**Distance between tracks  $\leq 0.8\text{mm}$ :**

- (a)  $Y \leq 1\text{mm}$ .
- (b) Z: Minimum space between two defects = 5mm.
- (c)  $e1 + e2 \geq 50\mu\text{m}$ . When adjacent tracks are from different resistors, this requirement becomes:  $e1 = e2 \geq 50\mu\text{m}$ .

**Distance between tracks  $> 0.8\text{mm}$ :**

- (d)  $Y \leq 1.5\text{mm}$ .
- (e) Z: Minimum space between two defects = 1.5mm.
- (f)  $e1 + e2 \geq 50\mu\text{m}$ . When adjacent tracks are from different resistors, this requirement becomes:  $e1 = e2 \geq 50\mu\text{m}$ .

**GOOD**

No metallic islet between tracks.

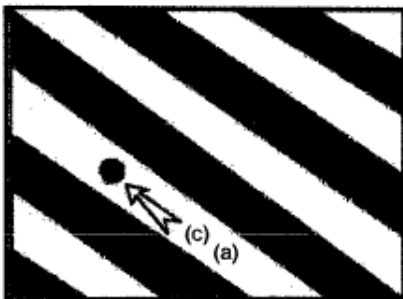
**ACCEPTABLE**

Gap between inclusion and tracks (c) is more and length of inclusion (a) is less than permitted limits.

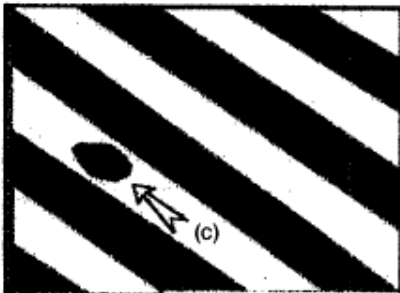
**REJECTED**

Gap between inclusion and tracks (c) is less than permitted limits.

#### 4.6.4 Lack of Metal

##### **Track width $\leq 0.8\text{mm}$ :**

- (a)  $X \leq 30\%$  of L.
- (b)  $Y \leq 0.5\text{mm}$ .
- (c) Z: Minimum space between two defects = 5mm.

##### **Track width $> 0.8\text{mm}$ :**

- (d)  $X \leq 25\%$  of L.
- (e)  $Y \leq 1\text{mm}$ .
- (f) Z: Minimum space between two defects = 1.5mm.

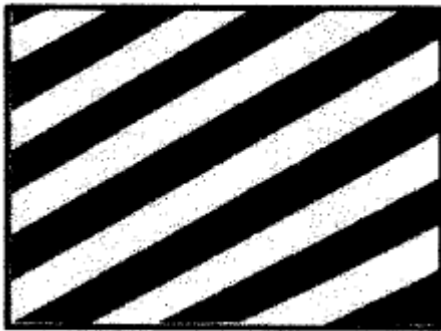

##### **GOOD**

No pinholes on tracks.

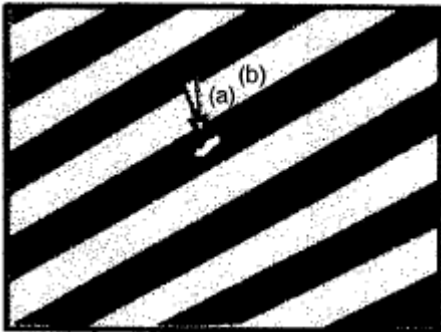

##### **ACCEPTABLE**

Track width reduction (a) and length of defect (b) are less than permitted limits.

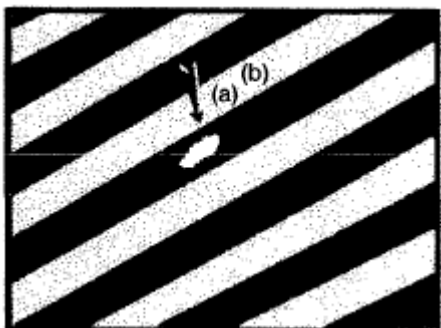

##### **REJECTED**

Track width reduction (a) or length of defect (b) is more than permitted limits.

#### 4.6.5 Other Random Defects

- (a) Short-circuits and cuts are rejected in every case.
- (b) Reduced insulation, reduced width, etc... (see Para. 4.6.1 for criteria).

4.7 DEFORMATION

4.7.1 Folds

**ACCEPTABLE**

Gentle curve.  
No blister on the substrate sticking face.

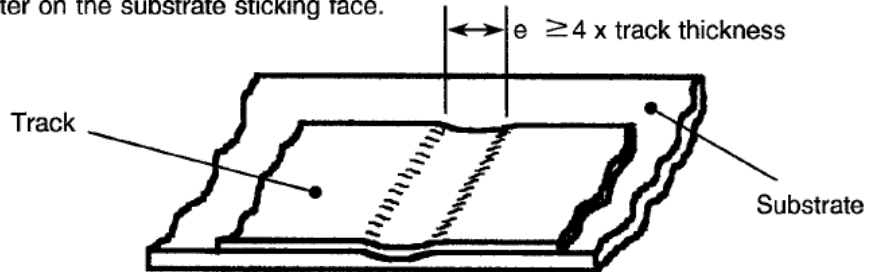

**REJECTED**

Sharp curve.  
Rugged fold.  
Blister on the substrate sticking face.

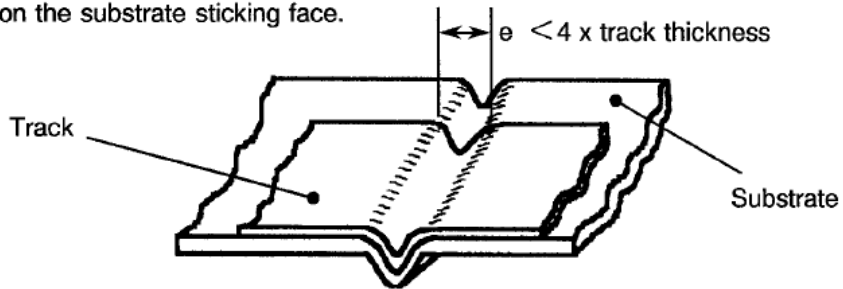

**REJECTED**

Void between track and substrate.  
Torn track.

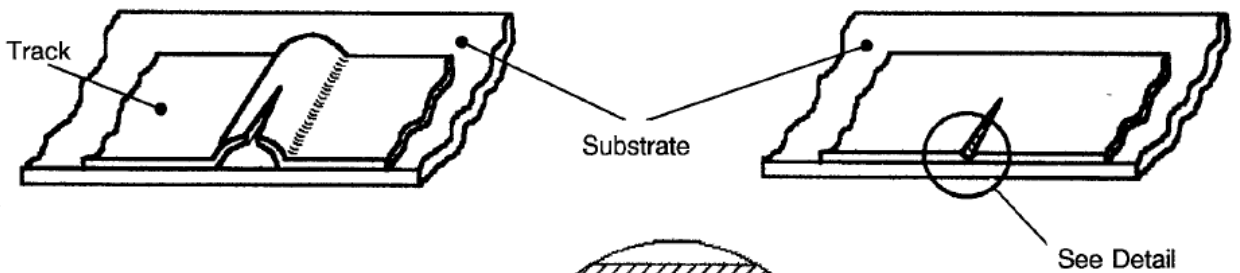

**DETAIL**

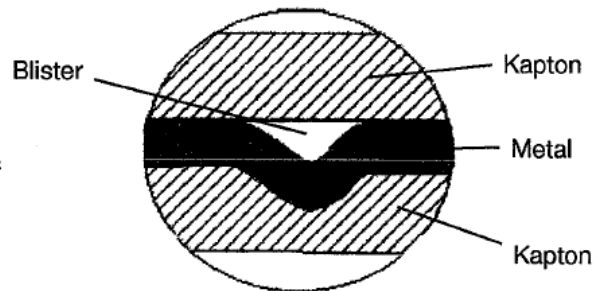



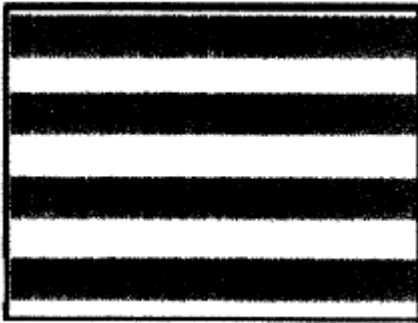

**GOOD**

No visual defects.  
No visible fold.

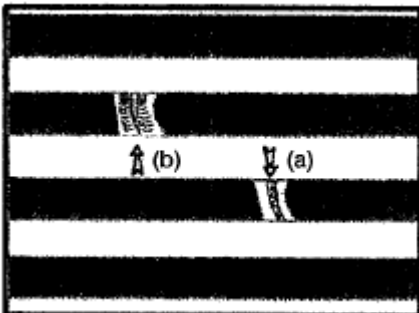

**ACCEPTABLE**

Fold is not very pronounced.  
Fold width is  $\geq 4 \times$  track thickness.  
No obvious delamination.  
No bump on heater surface.  
Fold does not result in an overthickness.

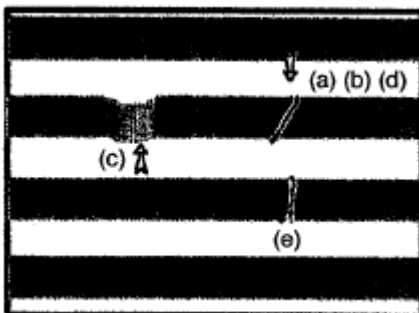

**REJECTED**

Fold is very pronounced.  
Rugged fold.  
Fold results in delamination.  
Nail detectable overthickness.  
Pronounced deformation and width fold below  $4 \times$  track thickness.

4.7.2 Slips

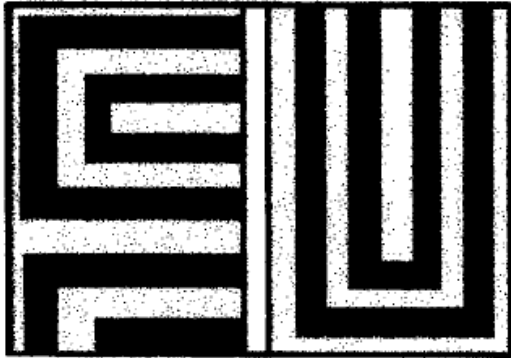

**GOOD**  
No track slippage.

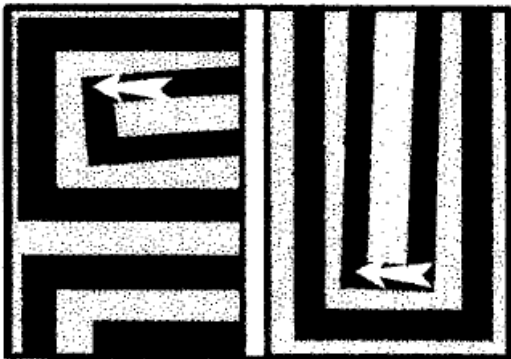

**ACCEPTABLE**  
Track slipped but minimum spacing between tracks is  $> 50\mu\text{m}$ .

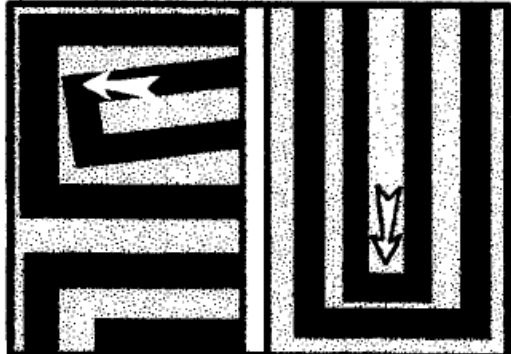

**REJECTED**  
Track slipped: minimum spacing between tracks is  $< 50\mu\text{m}$ .

4.7.3 Local Deformation**GOOD**

Tracks are smooth and without visible deformation.

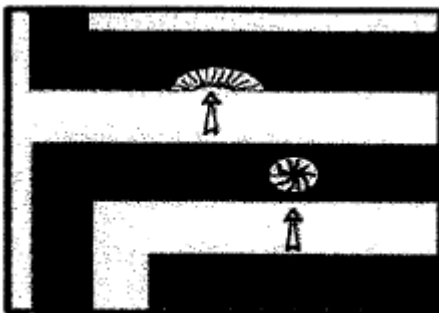
**ACCEPTABLE**

Deformation is well localized

Bump involves:

- Neither overthickness.
- Nor delamination.

**N.B. Acceptance criteria: No nail detectable deformation.**

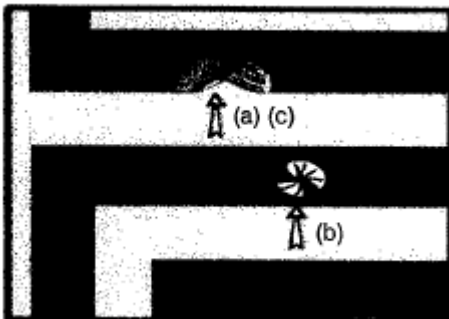
**REJECTED**

Excessive and large deformation.

Visible marks of cracking.

Nail detectable overthickness.

4.8 BLISTERING AND DELAMINATION

4.8.1 Track Unsticking

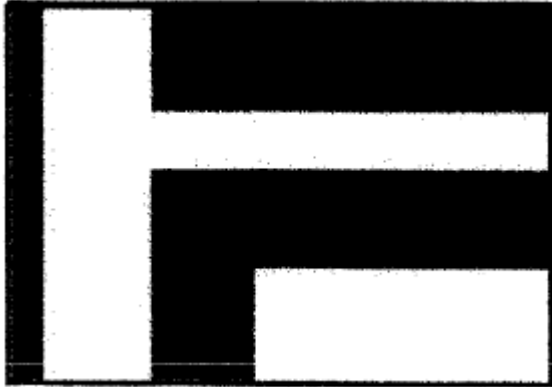

**GOOD**

No track area unstuck from the substrate.

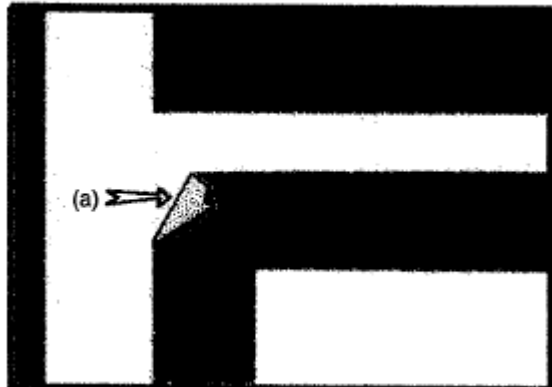

**REJECTED**

Moved and/or folded track corner.  
Kapton coverlay perforated during the pressing step.  
Unstuck track corner.

4.8.2 Delamination



**GOOD**

No visible point of delamination.

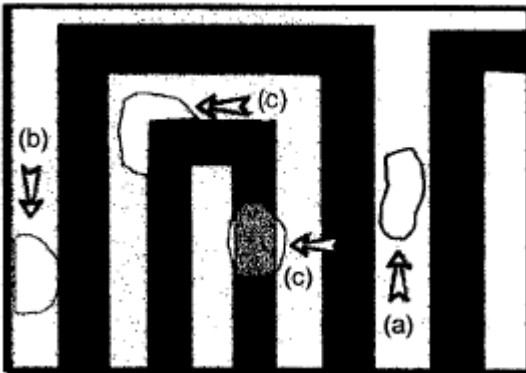

**REJECTED**

Bubbles:

- Cause excessive delamination between tracks.
- Stretch from track to heater edge.
- Are between track and substrate.

4.9

RAGGED EDGES

**N.B. GENERAL RULE** Minimum distance track/heater edge  $D = 0.4\text{mm}$ .

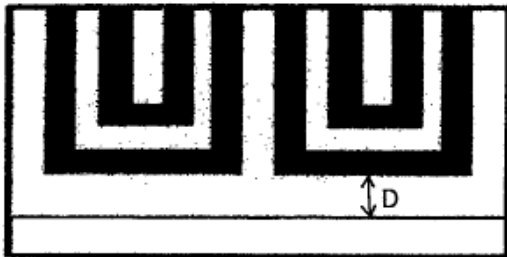

**GOOD**

Minimum distance  $D$  is respected. Heater edge is without notch.

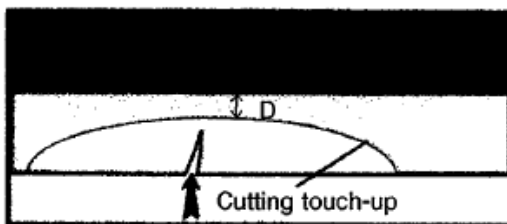

**ACCEPTABLE**

The heater edge is notched. This notch will be touched up (rounded) if:

- The notch is not in an area around lead wires (5mm on both sides).
- The minimum distance  $D$  is respected.

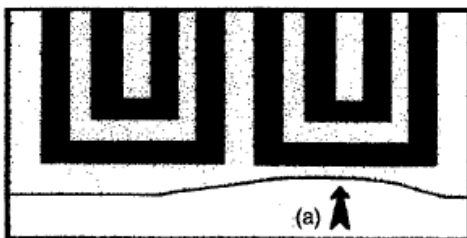

**REJECTED**

The minimum distance  $D$  is not respected.

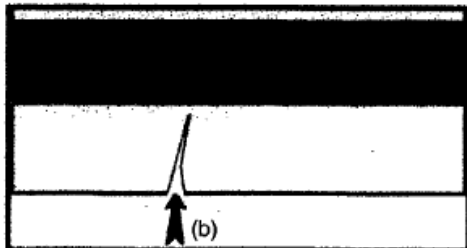

The notch is too profound and cannot be rounded with regard to the minimum distance.

4.10 ASPECT DEFECTS

4.10.1 Spots



**GOOD**

No spot visible on the heater.

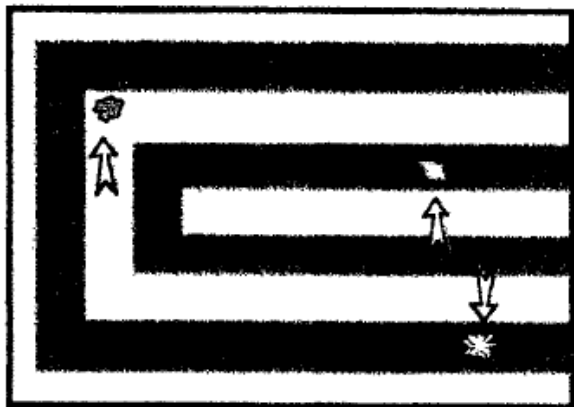

**ACCEPTABLE**

Isolated patch:

- Without presence of delamination.
- Gap between patch and tracks and length of patch less than permitted limits (see Para. 4.6.3).

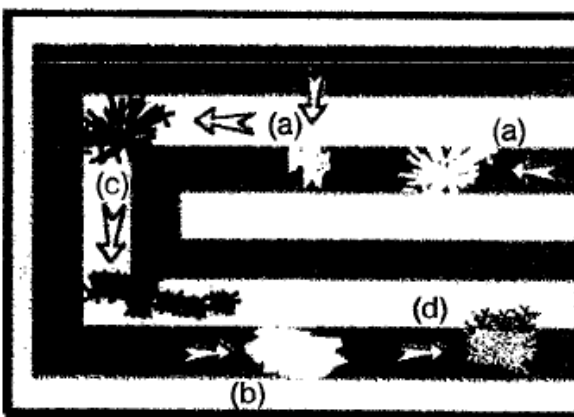

**REJECTED**

Large patches on and between tracks.  
 Patches showing delamination.  
 Group of patches.  
 Dark patches on the metallic surfaces.

4.10.2 Bubbles  
See also Para. 4.8.2, Delamination.



**GOOD**

No bubble visible on the heater.

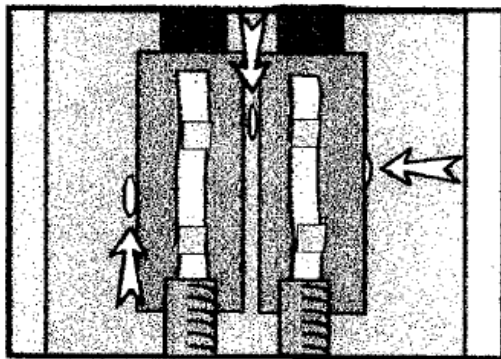

**ACCEPTABLE**

Bubbles coupled with metallic pad with regard to the following criteria:

- Size: 0 up to 200µm.
- Number: 5 maximum.

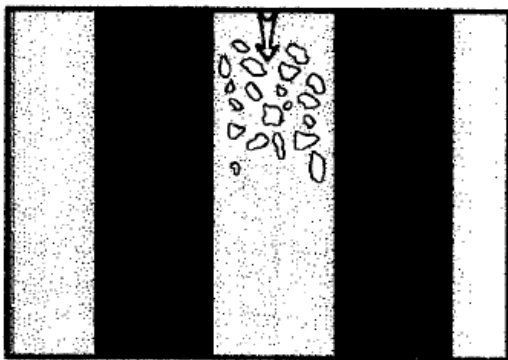

**REJECTED**

Bubbles make groups of white spots.



4.10.3 Surface Scratches



**GOOD**  
No evidence of scratch.



**ACCEPTABLE**  
Gentle scratches without Kapton removal or discontinuity.

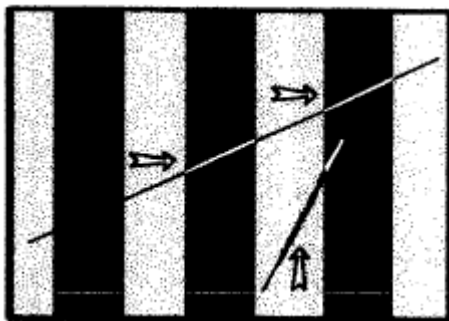

**REJECTED**  
Deep scratches with Kapton removal. Scratches exposing metal.

4.10.4 Non-Metallic Inclusions



**GOOD**

No evidence of inclusion on or between tracks.

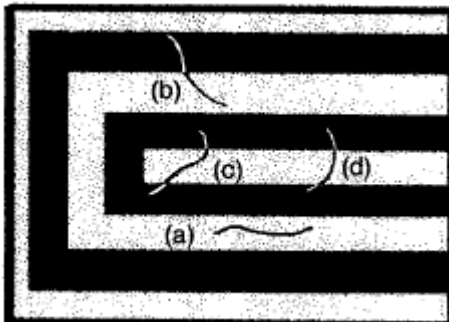

**ACCEPTABLE**

- (a) Inclusion respecting minimum spacing.
- (b) Inclusion does not make a whole bridge between two tracks (50µm respected).
- (c) Discontinuous inclusions (50µm).
- (d) Inclusion making a bridge between two tracks:
  - Limited length ( $\leq 2\text{mm}$ ); the limit of 2mm has to be measured as the maximum distance (segment) between the 2 extreme points of the inclusion. The non-metallic inclusion may have any geometrical shape.
  - Limited number according to the heater surface:
    - 0 up 20cm<sup>2</sup>:
      - 3 inclusions accepted by area of 10cm<sup>2</sup>.
      - 1 supplementary inclusion up 100cm<sup>2</sup>.
    - Beyond 100cm<sup>2</sup>:
      - 11 inclusions accepted.
      - Proximity criterion: 3 inclusions maximum in a 2cm diameter circle.

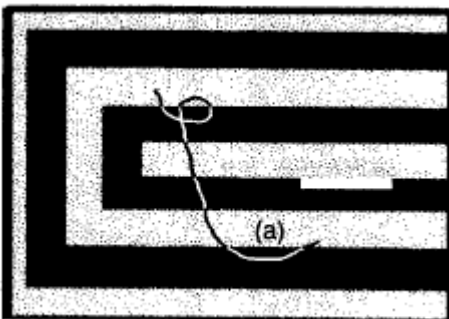

**REJECTED**

- (a) Inclusion making a bridge between two tracks whose number and/or configuration are not covered by previous criteria (length > 2mm).
- (b) Bright inclusion or being reminiscent of metallic glare.
- (c) Metallic inclusion.

4.11 MISREGISTRATION

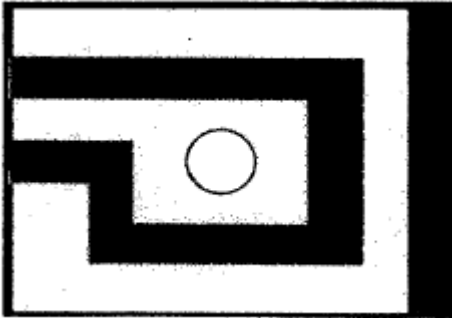

**GOOD**

Perforations are well centred in relation to tracks.

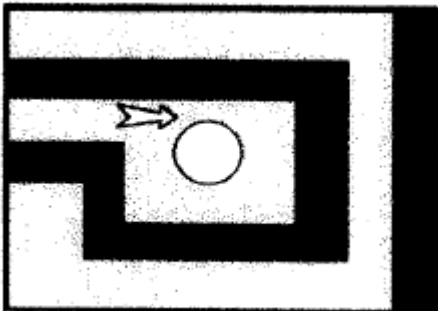

**ACCEPTABLE**

Perforations are misregistered in relation to tracks, but spacing between perforation edge/track edge is better than acceptable minimum (0.4mm).

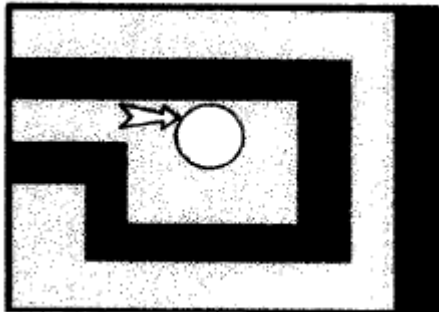

**REJECTED**

Spacing between perforation edge/track edge is less than acceptable minimum (0.4mm).