



**CAPACITORS, FIXED, SURFACE MOUNT,  
DC SELF-HEALING, NON-INDUCTIVE,  
POLYPHENYLENE SULPHIDE DIELECTRIC**

**BASED ON TYPE KM94S**

**ESCC Detail Specification No. 3006/023**

Issue 5	June 2020
---------	-----------



**LEGAL DISCLAIMER AND COPYRIGHT**

European Space Agency, Copyright © 2020. All rights reserved.

The European Space Agency disclaims any liability or responsibility, to any person or entity, with respect to any loss or damage caused, or alleged to be caused, directly or indirectly by the use and application of this ESCC publication.

This publication, without the prior permission of the European Space Agency and provided that it is not used for a commercial purpose, may be:

- copied in whole, in any medium, without alteration or modification.
- copied in part, in any medium, provided that the ESCC document identification, comprising the ESCC symbol, document number and document issue, is removed.

**DOCUMENTATION CHANGE NOTICE**

(Refer to <https://escies.org> for ESCC DCR content)

DCR No.	CHANGE DESCRIPTION
<a href="#">1316</a>	Specification updated to incorporate changes per DCR.

**TABLE OF CONTENTS**

1	GENERAL	5
1.1	SCOPE	5
1.2	APPLICABLE DOCUMENTS	5
1.3	TERMS, DEFINITIONS, ABBREVIATIONS, SYMBOLS AND UNITS	5
1.4	THE ESCC COMPONENT NUMBER AND COMPONENT TYPE VARIANTS	5
1.4.1	THE ESCC COMPONENT NUMBER	5
1.4.1.1	CHARACTERISTICS AND RATINGS CODES	5
1.4.2	COMPONENT TYPE VARIANTS AND RANGE OF COMPONENTS	6
1.5	MAXIMUM RATINGS	23
1.6	PHYSICAL DIMENSIONS	24
1.7	FUNCTIONAL DIAGRAM	24
2	REQUIREMENTS	24
2.1	GENERAL	24
2.1.1	DEVIATIONS FROM THE GENERIC SPECIFICATION	25
2.1.1.1	DEVIATIONS FROM QUALIFICATION AND PERIODIC TESTS – CHART F4	25
2.2	MARKING	25
2.3	ROBUSTNESS OF TERMINATIONS	25
2.4	ELECTRICAL MEASUREMENTS AT ROOM, HIGH AND LOW TEMPERATURES	26
2.4.1	ROOM TEMPERATURE ELECTRICAL MEASUREMENTS	26
2.4.2	HIGH AND LOW TEMPERATURES ELECTRICAL MEASUREMENTS	26
2.5	INTERMEDIATE AND END-POINT ELECTRICAL MEASUREMENTS	27
2.6	BURN-IN CONDITIONS	28
	APPENDIX 'A'	29

**1 GENERAL**

**1.1 SCOPE**

This specification details the ratings, physical and electrical characteristics, and test and inspection data for the component type variants and/or the Component Type Variants and Range of Components specified below. It supplements the requirements of, and shall be read in conjunction with, the ESCC Generic Specification listed under Applicable Documents.

**1.2 APPLICABLE DOCUMENTS**

The following documents form part of this specification and shall be read in conjunction with it:

- (a) ESCC Generic Specification No. [3006](#).

**1.3 TERMS, DEFINITIONS, ABBREVIATIONS, SYMBOLS AND UNITS**

For the purpose of this specification, the terms, definitions, abbreviations, symbols and units specified in ESCC Basic Specification No. [21300](#) shall apply.

**1.4 THE ESCC COMPONENT NUMBER AND COMPONENT TYPE VARIANTS**

**1.4.1 The ESCC Component Number**

The ESCC Component Number shall be constituted as follows:

Example: 3006023032433KE

- Detail Specification Reference: 3006023
- Component Type Variant Number: 03 (as required)
- Characteristic code: Capacitance Value (243nF): 2433 (as required)
- Characteristic code: Capacitance Tolerance ( $\pm 10\%$ ): K (as required)
- Rating code: Rated Voltage (100V): E (as required)

**1.4.1.1 *Characteristics and Ratings Codes***

Characteristics and ratings to be codified as part of the ESCC Component Number shall be as follows:

- (a) Capacitance Value, C, expressed by means of the following codes in accordance with ESCC Basic Specification No. [21700](#). The unit quantity shall be picofarads (pF).

Capacitance Value C (pF)	Code
XXX 10 <sup>1</sup>	XXX1
XXX 10 <sup>2</sup>	XXX2
XXX 10 <sup>3</sup>	XXX3
XXX 10 <sup>4</sup>	XXX4

- (b) Capacitance Tolerance expressed by the following codes in accordance with ESCC Basic Specification No. 21700:

Tolerance (±)	Code Letter
1%	F
2%	G
5%	J
10%	K

- (c) DC Rated Voltage,  $U_R$ , expressed by the following codes:

DC Rated Voltage $U_R$ (V)	Code Letter
50	C
100	E

1.4.2 Component Type Variants and Range of Components

The Component Type Variants and Range of Components applicable to this specification are as follows:

Type Variant (Note 1)	Capacitance Value (C) (nF)	Capacitance Tolerance (± %)	DC Rated Voltage ( $U_R$ ) (V)	AC Rated Current ( $I_{RA}$ ) (Arms)	Terminal Finish (Note 2)	Weight Max (g)
01	4.64	1, 2	50	0.07	3 or 4	0.6
	4.7	5, 10				
	4.75	1				
	4.87	1, 2				
	4.99	1				
	5.1	5				
	5.11	1, 2				
	5.23	1				
	5.36	1, 2				
	5.49	1				
	5.6	5, 10				
	5.62	1, 2				
	5.76	1				
	5.9	1, 2				
	6.04	1				
	6.19	1, 2				
	6.2	5				
6.34	1					
6.49	1, 2					

Type Variant (Note 1)	Capacitance Value (C) (nF)	Capacitance Tolerance ( $\pm$ %)	DC Rated Voltage ( $U_R$ ) (V)	AC Rated Current ( $I_{RA}$ ) (Arms)	Terminal Finish (Note 2)	Weight Max (g)
01	6.65	1	50	0.07	3 or 4	0.6
	6.8	5, 10		0.1		
	6.81	1, 2				
	6.98	1				
	7.15	1, 2				
	7.32	1				
	7.5	1, 2, 5				
	7.68	1				
	7.87	1, 2				
	8.06	1				
	8.2	5, 10				
	8.25	1, 2				
	8.45	1				
	8.66	1, 2				
	8.87	1				
	9.09	1, 2				
	9.1	5				
	9.31	1				
	9.53	1, 2				
	9.76	1				
	10	1, 2, 5, 10				
	10.2	1				
	10.5	1, 2				
	10.7	1				
	11	1, 2, 5				
	11.3	1				
	11.5	1, 2				
	11.8	1				
	12	5, 10				
	12.1	1, 2				
12.4	1					
12.7	1, 2					
13	1, 5					
13.3	1, 2					
13.7	1					

Type Variant (Note 1)	Capacitance Value (C) (nF)	Capacitance Tolerance ( $\pm$ %)	DC Rated Voltage ( $U_R$ ) (V)	AC Rated Current ( $I_{RA}$ ) (Arms)	Terminal Finish (Note 2)	Weight Max (g)
01	14	1, 2	50	0.1	3 or 4	0.6
	14.3	1				
	14.7	1, 2				
	15	1, 5, 10		0.15		
	15.4	1, 2				
	15.8	1				
	16	5				
	16.2	1, 2				
	16.5	1				
	16.9	1, 2				
	17.4	1				
	17.8	1, 2				
	18	5, 10				
	18.2	1				
	18.7	1, 2				
	19.1	1				
	19.6	1, 2				
	20	1, 5				
	20.5	1, 2				
	21	1				
	21.5	1, 2				
	22	5, 10		0.16		
	22.1	1				
	22.6	1, 2				
	23.2	1				
	23.7	1, 2				
	24	5				
	24.3	1				
24.9	1, 2					
25.5	1					
26.1	1, 2					
26.7	1					
27	5, 10					
27.4	1, 2					
28	1					



Type Variant (Note 1)	Capacitance Value (C) (nF)	Capacitance Tolerance ( $\pm$ %)	DC Rated Voltage ( $U_R$ ) (V)	AC Rated Current ( $I_{RA}$ ) (Arms)	Terminal Finish (Note 2)	Weight Max (g)
01	28.7	1, 2	50	0.16	3 or 4	0.6
	29.4	1				
	30	5				
	30.1	1, 2				
	30.9	1				
	31.6	1, 2				
	32.4	1				
	33	5, 10				
	33.2	1, 2				
	34	1				
	34.8	1, 2				
	35.7	1				
	36	5				
	36.5	1, 2				
	37.4	1				
	38.3	1, 2				
	39.2	1				
	40.2	1, 2				
	41.2	1				
	42.2	1, 2				
	43	5				
	43.2	1				
	44.2	1, 2				
	45.3	1				
	46.4	1, 2				
	47	5, 10				
	47.5	1				
	48.7	1, 2				
	49.9	1				
	51	5				
51.1	1, 2					
52.3	1					
53.6	1, 2					
54.9	1					
56	5, 10					
				0.21		

Type Variant (Note 1)	Capacitance Value (C) (nF)	Capacitance Tolerance ( $\pm$ %)	DC Rated Voltage ( $U_R$ ) (V)	AC Rated Current ( $I_{RA}$ ) (Arms)	Terminal Finish (Note 2)	Weight Max (g)
01	56.2	1, 2	50	0.21	3 or 4	0.6
	57.6	1				
	59	1, 2				
	60.4	1				
	61.9	1, 2				
	62	5				
	63.4	1				
	64.9	1, 2				
	66.5	1				
	68	5, 10				
	68.1	1, 2				
	69.8	1				
	71.5	1, 2				
	73.2	1				
	75	1, 5				
	76.8	1				
	78.7	1, 2				
	80.6	1				
	82	5, 10				
	82.5	1, 2				
	84.5	1				
	86.6	1, 2				
	88.7	1				
	90.9	1, 2				
	91	5				
	93.1	1				
	95.3	1, 2				
	97.6	1				
	100	1, 2, 5, 10				
	102	1				
105	1, 2					
107	1					
110	1, 2, 5					
113	1					
115	1, 2					
				0.3		
				0.4		

Type Variant (Note 1)	Capacitance Value (C) (nF)	Capacitance Tolerance ( $\pm$ %)	DC Rated Voltage ( $U_R$ ) (V)	AC Rated Current ( $I_{RA}$ ) (Arms)	Terminal Finish (Note 2)	Weight Max (g)	
01	118	1	50	0.4	3 or 4	0.6	
	120	5, 10					
	121	1, 2					
	124	1					
	127	1, 2					
	130	1, 5					
	133	1, 2					
	137	1					
	140	1, 2					
	143	1					
	147	1, 2					
	150	1, 5, 10					0.41
	154	1, 2					
	158	1					
	160	5					
	162	1, 2					
	165	1					
	169	1, 2					
	174	1					
	178	1, 2					
	180	5, 10					
	182	1					
	187	1, 2					
	191	1					
	196	1, 2					
	200	1, 5					
205	1, 2						
210	1						
215	1, 2						
220	5, 10	0.6					
221	1						
01	1	1, 2, 5, 10	100	0.03	3 or 4	0.6	
	1.02	1					
	1.05	1, 2					
	1.07	1					

Type Variant (Note 1)	Capacitance Value (C) (nF)	Capacitance Tolerance ( $\pm$ %)	DC Rated Voltage ( $U_R$ ) (V)	AC Rated Current ( $I_{RA}$ ) (Arms)	Terminal Finish (Note 2)	Weight Max (g)
01	1.1	1, 2, 5	100	0.03	3 or 4	0.6
	1.13	1				
	1.15	1, 2				
	1.18	1				
	1.2	5, 10				
	1.21	1, 2				
	1.24	1				
	1.27	1, 2				
	1.3	1, 2				
	1.33	1, 2				
	1.37	1				
	1.4	1, 2				
	1.43	1				
	1.47	1, 2				
	1.5	1, 5, 10				
	1.54	1, 2				
	1.58	1				
	1.6	5				
	1.62	1, 2				
	1.65	1				
	1.69	1, 2				
	1.74	1				
	1.78	1, 2				
	1.8	5, 10				
	1.82	1				
	1.87	1, 2				
	1.91	1				
	1.96	1, 2				
	2	1, 5				
	2.05	1, 2				
2.1	1					
2.15	1, 2					
2.2	5, 10					
2.21	1					
2.26	1, 2					

Type Variant (Note 1)	Capacitance Value (C) (nF)	Capacitance Tolerance ( $\pm$ %)	DC Rated Voltage ( $U_R$ ) (V)	AC Rated Current ( $I_{RA}$ ) (Arms)	Terminal Finish (Note 2)	Weight Max (g)
01	2.32	1	100	0.07	3 or 4	0.6
	2.37	1, 2				
	2.4	5				
	2.43	1				
	2.49	1, 2				
	2.55	1				
	2.61	1, 2				
	2.67	1				
	2.7	5, 10				
	2.74	1, 2				
	2.8	1				
	2.87	1, 2				
	2.94	1				
	3	5				
	3.01	1, 2				
	3.09	1				
	3.16	1, 2				
	3.24	1				
	3.3	5, 10				
	3.32	1, 2				
	3.4	1				
	3.48	1, 2				
	3.57	1				
	3.6	5				
	3.65	1, 2				
	3.74	1				
	3.83	1, 2				
	3.9	5, 10				
	3.92	1				
	4.02	1, 2				
4.12	1					
4.22	1, 2					
4.3	5					
4.32	1					
4.42	1, 2					
				0.11		

Type Variant (Note 1)	Capacitance Value (C) (nF)	Capacitance Tolerance ( $\pm$ %)	DC Rated Voltage ( $U_R$ ) (V)	AC Rated Current ( $I_{RA}$ ) (Arms)	Terminal Finish (Note 2)	Weight Max (g)
01	4.53	1	100	0.11	3 or 4	0.6
	4.64	1, 2				
	4.7	5, 10				
	4.75	1				
	4.87	1, 2				
	4.99	1				
	5.1	5				
	5.11	1, 2				
	5.23	1				
	5.36	1, 2				
	5.49	1				
	5.6	5, 10				
	5.62	1, 2				
	5.76	1				
	5.9	1, 2				
	6.04	1				
	6.19	1, 2				
	6.2	5				
	6.34	1				
	6.49	1, 2				
	6.65	1				
	6.8	5, 10				
	6.81	1, 2				
	6.98	1				
	7.15	1, 2				
	7.32	1				
	7.5	1, 2, 5				
	7.68	1				
	7.87	1, 2				
	8.06	1				
8.2	5, 10					
8.25	1, 2					
8.45	1					
8.66	1, 2					
8.87	1					

Type Variant (Note 1)	Capacitance Value (C) (nF)	Capacitance Tolerance ( $\pm$ %)	DC Rated Voltage ( $U_R$ ) (V)	AC Rated Current ( $I_{RA}$ ) (Arms)	Terminal Finish (Note 2)	Weight Max (g)
01	9.09	1, 2	100	0.13	3 or 4	0.6
	9.1	5				
	9.31	1				
	9.53	1, 2				
	9.76	1				
	10	1, 2, 5, 10				
	10.2	1				
	10.5	1, 2				
	10.7	1				
	11	1, 2, 5				
	11.3	1				
	11.5	1, 2				
	11.8	1				
	12	5, 10				
	12.1	1, 2				
	12.4	1				
	12.7	1, 2				
	13	1, 5				
	13.3	1, 2				
	13.7	1				
	14	1, 2				
	14.3	1				
	14.7	1, 2				
	15	1, 5, 10		0.19		
	15.4	1, 2				
	15.8	1				
	16	5				
	16.2	1, 2				
	16.5	1				
	16.9	1, 2				
17.4	1					
17.8	1, 2					
18	5, 10					
18.2	1					
18.7	1, 2					

Type Variant (Note 1)	Capacitance Value (C) (nF)	Capacitance Tolerance ( $\pm$ %)	DC Rated Voltage ( $U_R$ ) (V)	AC Rated Current ( $I_{RA}$ ) (Arms)	Terminal Finish (Note 2)	Weight Max (g)
01	19.1	1	100	0.19	3 or 4	0.6
	19.6	1, 2				
	20	1, 5				
	20.5	1, 2				
	21	1				
	21.5	1, 2				
	22	5, 10				
	22.1	1				
	22.6	1, 2				
	23.2	1				
	23.7	1, 2				
	24	5				
	24.3	1				
	24.9	1, 2				
	25.5	1				
	26.1	1, 2				
	26.7	1				
	27	5, 10				
	27.4	1, 2				
	28	1				
	28.7	1, 2				
	29.4	1				
	30	5				
	30.1	1, 2				
	30.9	1				
	31.6	1, 2				
	32.4	1				
	33	5, 10				
	33.2	1, 2				
	34	1				
34.8	1, 2					
35.7	1					
36	5					
36.5	1, 2					
37.4	1					
				0.2		
				0.26		



Type Variant (Note 1)	Capacitance Value (C) (nF)	Capacitance Tolerance ( $\pm$ %)	DC Rated Voltage ( $U_R$ ) (V)	AC Rated Current ( $I_{RA}$ ) (Arms)	Terminal Finish (Note 2)	Weight Max (g)
01	38.3	1, 2	100	0.26	3 or 4	0.6
	39	5, 10				
	39.2	1				
	40.2	1, 2				
	41.2	1				
	42.2	1, 2				
	43	5				
	43.2	1				
	44.2	1, 2				
	45.3	1				
	46.4	1, 2				
	47	5, 10				
	47.5	1				
	48.7	1, 2				
	49.9	1				
	51	5				
	51.1	1, 2				
	52.3	1				
	53.6	1, 2				
	54.9	1				
	56	5, 10				
	56.2	1, 2				
	57.6	1				
	59	1, 2				
	60.4	1				
	61.9	1, 2				
	62	5				
	63.4	1				
	64.9	1, 2				
	66.5	1				
68	5, 10	0.38				
68.1	1, 2					
69.8	1					
71.5	1, 2					
73.2	1					

Type Variant (Note 1)	Capacitance Value (C) (nF)	Capacitance Tolerance ( $\pm$ %)	DC Rated Voltage ( $U_R$ ) (V)	AC Rated Current ( $I_{RA}$ ) (Arms)	Terminal Finish (Note 2)	Weight Max (g)
01	75	1, 2, 5	100	0.38	3 or 4	0.6
	76.8	1				
	78.7	1, 2				
	80.6	1				
	82	5, 10				
	82.5	1, 2				
	84.5	1				
	86.6	1, 2				
	88.7	1				
	90.9	1, 2				
	91	5				
	93.1	1				
	95.3	1, 2				
	97.6	1				
	100	1, 2, 5, 10		0.41		
02	226	1, 2	50	0.6	3 or 4	0.9
	232	1				
	237	1, 2				
	240	5				
	243	1				
	249	1, 2				
	255	1				
	261	1, 2				
	267	1				
	270	5, 10				
	274	1, 2				
	280	1				
	287	1, 2				
	294	1				
	300	5				
	301	1, 2				
	309	1				
	316	1, 2				
	324	1				
330	5, 10					

Type Variant (Note 1)	Capacitance Value (C) (nF)	Capacitance Tolerance ( $\pm$ %)	DC Rated Voltage ( $U_R$ ) (V)	AC Rated Current ( $I_{RA}$ ) (Arms)	Terminal Finish (Note 2)	Weight Max (g)
02	332	1, 2	50	0.9	3 or 4	0.9
	340	1				
	348	1, 2				
	357	1				
	360	5				
	365	1, 2				
	374	1				
	383	1, 2				
	390	5, 10				
	392	1				
	402	1, 2				
	412	1				
	422	1, 2				
	430	5				
	432	1				
	442	1, 2				
	453	1				
	464	1, 2				
	470	5, 10		1.28		
02	102	1	100	0.41	3 or 4	0.9
	105	1, 2				
	107	1				
	110	1, 2, 5				
	113	1				
	115	1, 2				
	118	1				
	120	5, 10				
	121	1, 2				
	124	1				
	127	1, 2				
	130	1, 5				
	133	1, 2				
	137	1				
	140	1, 2				
	143	1				

Type Variant (Note 1)	Capacitance Value (C) (nF)	Capacitance Tolerance ( $\pm$ %)	DC Rated Voltage ( $U_R$ ) (V)	AC Rated Current ( $I_{RA}$ ) (Arms)	Terminal Finish (Note 2)	Weight Max (g)
02	147	1, 2	100	0.41	3 or 4	0.9
	150	1, 5, 10		0.84		
	154	1, 2				
	158	1				
	160	5				
	162	1, 2				
	165	1				
	169	1, 2				
	174	1				
	178	1, 2				
	180	5, 10				
	182	1				
	187	1, 2				
	191	1				
	196	1, 2				
	200	1, 5				
	205	1, 2				
210	1					
215	1, 2					
220	5, 10		0.91			
03	475	1	50	1.28	3 or 4	1.3
	487	1, 2				
	499	1				
	510	5				
	511	1, 2				
	523	1				
	536	1, 2				
	549	1				
	560	5, 10				
	562	1, 2				
	576	1				
	590	1, 2				
	604	1				
	619	1, 2				
	620	5				

Type Variant (Note 1)	Capacitance Value (C) (nF)	Capacitance Tolerance ( $\pm$ %)	DC Rated Voltage ( $U_R$ ) (V)	AC Rated Current ( $I_{RA}$ ) (Arms)	Terminal Finish (Note 2)	Weight Max (g)
03	634	1	50	1.28	3 or 4	1.3
	649	1, 2				
	665	1				
	680	5, 10				
	681	1, 2				
	698	1				
	715	1, 2				
	732	1				
	750	1, 2				
	768	1				
	787	1, 2				
	806	1				
	820	5, 10				
	825	1, 2				
	845	1				
	866	1, 2				
	887	1				
	909	1, 2				
	910	5				
	931	1				
953	1, 2					
976	1					
1000	1, 2, 5, 10					
03	221	1	100	0.91	3 or 4	1.3
	226	1, 2				
	232	1				
	237	1, 2				
	240	5				
	243	1				
	249	1, 2				
	255	1				
	261	1, 2				
	267	1				
	270	5, 10				
	274	1, 2				

Type Variant (Note 1)	Capacitance Value (C) (nF)	Capacitance Tolerance ( $\pm$ %)	DC Rated Voltage ( $U_R$ ) (V)	AC Rated Current ( $I_{RA}$ ) (Arms)	Terminal Finish (Note 2)	Weight Max (g)	
03	280	1	100	0.91	3 or 4	1.3	
	287	1, 2					
	294	1					
	300	5					
	301	1, 2					
	309	1					
	316	1, 2					
	324	1					
	330	5, 10					1.19
	332	1, 2					
	340	1					
	348	1, 2					
	357	1					
	360	5					
	365	1, 2					
	374	1					
	383	1, 2					
	390	5, 10					
	392	1					
	402	1, 2					
	412	1					
	422	1, 2					
	430	5					
	432	1					
	442	1, 2					
	453	1					
464	1, 2						
470	5, 10	1.3					

**NOTES:**

1. See Para. 1.6.
2. Terminal finishes shall be in accordance with the requirements of ESCC Basic Specification No. [23500](#).

**1.5** MAXIMUM RATINGS

The maximum ratings shall not be exceeded at any time during use or storage.

Maximum ratings shall only be exceeded during testing to the extent specified in this specification and when stipulated in Test Methods and Procedures of the ESCC Generic Specification.

Characteristics	Symbols	Maximum Ratings	Units	Remarks
DC Rated Voltage	$U_R$	50, 100	V	Note 1
AC Rated Voltage	$U_A$	$35\%U_R$	Vrms	50/60Hz
AC Rated Current	$I_{RA}$	See Para. 1.4.2	Arms	100kHz
Operating Temperature Range	$T_{op}$	-55 to +125	°C	$T_{amb}$
Storage Temperature Range	$T_{stg}$	-55 to +125	°C	
Soldering Temperature	$T_{sol}$	+215	°C	Note 2

**NOTES:**

1. As required; See Para. 1.4.2.
2. For reflow soldering:
  - Temperature: +215°C
  - Duration: 40 seconds maximum.

1.6 PHYSICAL DIMENSIONS

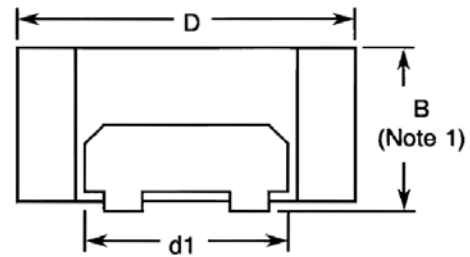
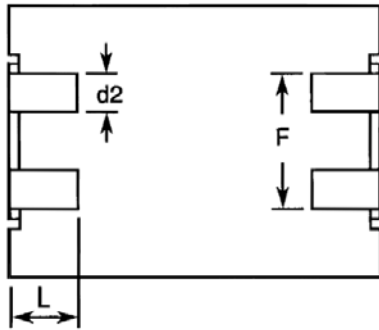

Type Variant	Dimensions (mm)										
	A Max	B Max	D Max	d1		d2		F		L	
				Min	Max	Min	Max	Min	Max	Min	Max
01	8	4.5	7.5	3.5	4.5	0.8	1.2	3.8	4.2	1.5	2.5
02	8	7.5	8.5	3.5	4.5	0.8	1.2	3.8	4.2	1.5	2.5
03	10.7	7.5	10.7	3.5	4.5	1.3	1.8	4.8	5.2	1.5	2.5

1.7 FUNCTIONAL DIAGRAM



2 REQUIREMENTS

2.1 GENERAL

The complete requirements for procurement of the components specified herein are as stated in this specification and the ESCC Generic Specification. Permitted deviations from the Generic Specification, applicable to this specification only, are listed below.

Permitted deviations from the Generic Specification and this Detail Specification, formally agreed with specific Manufacturers on the basis that the alternative requirements are equivalent to the ESCC requirement and do not affect the component's reliability, are listed in the appendices attached to this specification.



### 2.1.1 Deviations from the Generic Specification

#### 2.1.1.1 *Deviations from Qualification and Periodic Tests – Chart F4*

- (a) Mounting:  
Prior to the commencement of Chart F4 Subgroups 1A, 1B, 2A and 2B, components may be mounted on a suitable substrate in accordance with IEC Publication No. 60384-1, Clause 4.33. After mounting, a force of 10N shall be applied normal to a line joining the terminals and in a plane parallel to the substrate for a duration of 10s. There shall be no evidence of damage or loosening of the components from the substrate.
- (b) Operating Life, Test Condition (c), Applied voltage:  $1.25 \times U_R$
- (c) Solderability shall be performed in accordance with IEC Publication No. 60068-2-58. The following details shall apply:
- Test Conditions:
    - Temperature:  $+215 \pm 3^\circ\text{C}$
    - Immersion time:  $3 \pm 0.3\text{s}$
    - Immersion distance: 1mm minimum, 2mm maximum.
- (d) Resistance to Soldering Heat shall be performed in accordance with IEC Publication No. 60068-2-58. The following details shall apply:
- Test Conditions:
    - Temperature:  $+215 \pm 3^\circ\text{C}$
    - Immersion time: 40s
    - Immersion distance: 1mm minimum, 2mm maximum.
  - Data Points: As defined in Resistance to Soldering Heat in the Generic Specification.

### 2.2 MARKING

The marking shall be in accordance with the requirements of ESCC Basic Specification No. [21700](#) and as follows.

The information to be marked on the component or its primary package shall be:

- (a) The ESCC qualified components symbol (for ESCC qualified components only).
- (b) The ESCC Component Number (see Para. 1.4.1).
- (c) Traceability information.

### 2.3 ROBUSTNESS OF TERMINATIONS

The terminals of the components are rigid.

The test conditions for Robustness of Terminations shall be as specified in the ESCC Generic Specification and as follows:

- Test  $U_a$ , with an applied force of 10N and a duration of  $10 \pm 1\text{s}$ .

Both terminals of the component shall be tested.

2.4 **ELECTRICAL MEASUREMENTS AT ROOM, HIGH AND LOW TEMPERATURES**

Electrical measurements shall be performed at room, high and low temperatures.

2.4.1 **Room Temperature Electrical Measurements**

The measurements shall be performed at  $T_{amb} = +22 \pm 3^{\circ}\text{C}$ .

Characteristics	Symbols	Test Method and Conditions	Limits		Units
			Min	Max	
Capacitance	C	ESCC No. 3006 Test Frequency = 1kHz	Note 1	Note 2	nF
Tangent of Loss Angle	tgδ	ESCC No. 3006 Test Frequency = 1kHz	-	20x10 <sup>-4</sup>	-
Insulation Resistance, Dielectric	R <sub>I</sub>	ESCC No. 3006  C ≤ 330nF C > 330nF	30	-	GΩ
			10	-	GΩ.nF
Insulation Resistance, Body Insulation	R <sub>IB</sub>	ESCC No. 3006	50	-	GΩ
Voltage Proof, Terminal-to-Terminal	VP	ESCC No. 3006	1.6xU <sub>R</sub> (Note 3)	-	V
Voltage Proof, Terminal-to-Case	VP <sub>B</sub>	ESCC No. 3006	1.6xU <sub>R</sub> (Note 3)	-	V

**NOTES:**

1. Capacitance Value of the component minus the applicable Tolerance (see Para. 1.4.2).
2. Capacitance Value of the component plus the applicable Tolerance (see Para. 1.4.2).
3. For the applicable Rated Voltage (U<sub>R</sub>) see Para. 1.4.2.

2.4.2 **High and Low Temperatures Electrical Measurements**

Characteristics	Symbols	Test Method and Conditions (Note 1)	Limits		Units
			Min	Max	
Temperature Coefficient	ΔC/C	ESCC No. 3006 Test Frequency = 1kHz  T <sub>amb</sub> = -55 ±2°C	-3 (Note 2)	+3 (Note 2)	%
			-3 (Note 2)	+3 (Note 2)	%

**NOTES:**

1. The measurements shall be performed on a sample of 6 components from each manufacturing lot with 0 failures allowed. In the event of any failure a 100% inspection may be performed.
2. The Temperature Coefficient limits are with respect to the capacitance at +22 ±2°C (reference point temperature).

2.5 INTERMEDIATE AND END-POINT ELECTRICAL MEASUREMENTS

Unless otherwise specified, the measurements shall be performed at  $T_{amb} = +22 \pm 3^{\circ}\text{C}$ .

Unless otherwise specified the test methods and test conditions shall be as per the corresponding test defined in Para. 2.4.1, Room Temperature Electrical Measurements.

Test Reference per ESCC No. 3006	Characteristics	Symbols	Limits		Units
			Min	Max	
Resistance to Soldering Heat Initial Measurements Final Measurements	Capacitance	C	Note 1		nF
	Capacitance	C	Note 1		nF
	Change in Capacitance	$\Delta C/C$	-2	+2	%
	Insulation Resistance, Dielectric	$R_i$			
	$C \leq 330\text{nF}$ $C > 330\text{nF}$		Note 1 Note 1	- -	$G\Omega$ $G\Omega.nF$
	Tangent of Loss Angle	$tg\delta$	-	Note 1	-
Temperature Coefficient	Temperature Coefficient (Note 2)	$\Delta C/C$	Note 3		%
Rapid Change of Temperature Initial Measurements Final Measurements	Capacitance	C	Note 1		nF
	Capacitance	C	Note 1		nF
	Change in Capacitance	$\Delta C/C$	-1	+1	%
	Tangent of Loss Angle	$tg\delta$	-	Note 1	-
Climatic Sequence Initial Measurements Final Measurements	Capacitance	C	Note 1		nF
	Capacitance	C	Note 1		nF
	Change in Capacitance	$\Delta C/C$	-1	+1	%
	Tangent of Loss Angle	$tg\delta$	-	$50 \times 10^{-4}$	-
	Voltage Proof, Terminal-to-Terminal	VP	Note 1	-	V
	Voltage Proof, Terminal-to-Case	$VP_B$	Note 4	-	V
	Insulation Resistance, Dielectric	$R_i$			
	$C \leq 330\text{nF}$ $C > 330\text{nF}$		Note 5 Note 5	- -	$G\Omega$ $G\Omega.nF$
	Insulation Resistance, Body Insulation	$R_{IB}$	Note 5	-	$G\Omega$

Test Reference per ESCC No. 3006	Characteristics	Symbols	Limits		Units
			Min	Max	
Operating Life					
Initial Measurements	Capacitance	C	Note 1		nF
Intermediate Measurements (1000 hours)	Capacitance	C	Note 1		nF
	Change in Capacitance	$\Delta C/C$	-2	+2	%
Final Measurements (1000 or 2000 hours) (Note 6)	Capacitance	C	Note 1		nF
	Change in Capacitance	$\Delta C/C$	-2	+2	%
	Tangent of Loss Angle	$tg\delta$	-	Note 7	-
	Insulation Resistance, Dielectric	$R_i$			
	C ≤ 330nF		Note 5	-	GΩ
	C > 330nF		Note 5	-	GΩ.nF
	Insulation Resistance, Body Insulation	$R_{IB}$	Note 5	-	GΩ

**NOTES:**

- As specified in Para. 2.4.1.
- The test method and test conditions shall be as specified in Para. 2.4.2.
- As specified in Para. 2.4.2.
- $1.6 \times U_R$  or 200V, whichever is greater. For the applicable Rated Voltage ( $U_R$ ) see Para. 1.4.2.
- 50% of the limit specified in Para. 2.4.1.
- 1000 hours is applicable to Periodic Testing for extension of qualification. 2000 hours is applicable to Qualification Testing, and to Periodic Testing for renewal of qualification after lapse.
- 2x the limit specified in Para. 2.4.1.

2.6

**BURN-IN CONDITIONS**

Characteristics	Symbols	Conditions (Note 1)	Units
Ambient Temperature	$T_{amb}$	+125 (+0 -5)	°C
Test Voltage	$V_T$	$1.25 \times U_R$ (Note 2)	V

**NOTES:**

- On completion of Burn-in the components shall be removed from the burn-in chamber and allowed to cool, under normal atmospheric conditions, for recovery for 24 ±2 hours.
- For the applicable Rated Voltage ( $U_R$ ) see Para. 1.4.2.

**APPENDIX 'A'**  
**AGREED DEVIATIONS FOR EXXELIA TECHNOLOGIES (F)**

Items Affected	Description of Deviations
<p>Para. 2.1.1, Deviations from the Generic Specification: Deviations from Screening Tests – Chart F3</p>	<p>All procurement lots shall have 100% Serialisation carried out at any point during Chart F3 testing prior to the performance of High and Low Temperatures Electrical Measurements.</p> <p>If a particular lot is required to undergo testing in accordance with Chart F4, then the Temperature Coefficient measurements, made during High and Low Temperatures Electrical Measurements on a sample of 6 randomly-selected serialised capacitors, shall be Read-and-Record measurements. See “Deviations from Qualification and Periodic Tests – Chart F4” below.</p> <p>These measurements may also be performed at the end of Chart F3 in order that the sample of components can include any components which passed post-Burn-in Room Temperature Electrical Measurements but subsequently failed External Visual Inspection.</p>
<p>Para. 2.1.1.1, Deviations from Qualification and Periodic Tests – Chart F4</p>	<p>Robustness of Terminations shall be performed as follows:  The components shall be mounted on a suitable substrate. After mounting, examination shall be made for good tinning as evidenced by flowing of the solder with wetting of the terminations. A force of 10N shall be applied normal to the line joining the terminals and in a plane parallel to the substrate, for a duration of 10 ±1s. The components shall then be examined and there shall be no evidence of damage or loosening of the components from the substrate.</p> <p>The Temperature Coefficient testing specified in Subgroup 2B of Chart F4 may not be performed.</p> <p>In instances when Temperature Coefficient testing per Subgroup 2B of Chart F4 is not performed, the Read-and-Record measurements data obtained during High and Low Temperature Electrical Measurements (part of Chart F3, Screening Tests) shall be submitted instead.</p>