



**CONTACTS, POWER, PRESS-FIT TYPE FOR  
3401/098 CONNECTORS**

**ESCC Detail Specification No. 3401/099**

Issue 1	November 2021
---------	---------------



Document Custodian: European Space Agency – see <https://escies.org>

**LEGAL DISCLAIMER AND COPYRIGHT**

European Space Agency, Copyright © 2021. All rights reserved.

The European Space Agency disclaims any liability or responsibility, to any person or entity, with respect to any loss or damage caused, or alleged to be caused, directly or indirectly by the use and application of this ESCC publication.

This publication, without the prior permission of the European Space Agency and provided that it is not used for a commercial purpose, may be:

- copied in whole, in any medium, without alteration or modification.
- copied in part, in any medium, provided that the ESCC document identification, comprising the ESCC symbol, document number and document issue, is removed.

**DOCUMENTATION CHANGE NOTICE**

(Refer to <https://escies.org> for ESCC DCR content)

DCR No.	CHANGE DESCRIPTION

**TABLE OF CONTENTS**

1	GENERAL	6
1.1	SCOPE	6
1.2	TYPE VARIANTS	6
1.3	MAXIMUM RATINGS	6
1.4	PARAMETER DERATING INFORMATION (FIGURE 1)	6
1.5	PHYSICAL DIMENSIONS	6
2	APPLICABLE DOCUMENTS	9
3	TERMS, DEFINITIONS, ABBREVIATIONS, SYMBOLS AND UNITS	9
4	REQUIREMENTS	9
4.1	GENERAL	9
4.2	DEVIATIONS FROM GENERIC SPECIFICATION	9
4.2.1	Deviations from Special In-Process Controls	9
4.2.2	Deviations from Final Production Tests (Chart II)	10
4.2.3	Deviations from Burn-in and Electrical Measurements (Chart III)	10
4.2.4	Deviations from Qualification Tests (Chart IV)	10
4.2.5	Deviations from Lot Acceptance Tests (Chart V)	10
4.3	MECHANICAL REQUIREMENTS	10
4.3.1	Dimension Check	10
4.3.2	Weight	10
4.3.3	Contact Capability (Variant 02)	10
4.3.4	Contact Retention (in Insert)	10
4.3.5	Contact Insertion and Withdrawal Forces	10
4.3.6	Engagement and Separation Forces (Variant 02)	11
4.3.7	Press-fit Insertion Force	11
4.4	MATERIALS AND FINISHES	11
4.4.1	Contact Body	11
4.4.2	Retention Clip	11
4.4.3	Magnetism Level	11
4.5	MARKING	11
4.5.1	General	11
4.5.2	The ESCC Component Number	12
4.5.3	Traceability Information	12
4.6	ELECTRICAL MEASUREMENTS	12
4.6.1	Electrical Measurements at Room Temperature	12
4.7	ENVIRONMENTAL AND ENDURANCE TESTS	12
4.7.1	Measurements and Inspections on Completion of Environmental Tests	12



4.7.2	Measurements and Inspections on Completion of Endurance Tests	12
4.7.3	Conditions for High Temperature Storage Test (Part of Endurance Testing)	12

## 1 GENERAL

### 1.1 SCOPE

This specification details the ratings, physical and electrical characteristics, test and inspection data for Contacts, Power, Press-fit Type for 3401/098 Connectors.

The specification shall be read in conjunction with:

- ESCC Generic Specification No. 3401, Connectors, Electrical, Non-Filtered, Circular and Rectangular.
- ESCC Detail Specification No. 3401/098, Connectors, Electrical, Rectangular, Non-removable Signal Press-fit Contacts and Removable Power Press-fit Contacts, Based on Types SDD, SND, SCBM.

the requirements of which are supplemented herein.

These contacts are not mounted in the connectors and are therefore delivered separately.

### 1.2 TYPE VARIANTS

Variants of the basic type contacts specified herein, which are covered by this specification, together with their mechanical characteristics, are given in Table 1(a).

### 1.3 MAXIMUM RATINGS

The maximum ratings, which shall not be exceeded at any time during use or storage, applicable to the contacts specified herein, are scheduled in Table 1(b).

### 1.4 PARAMETER DERATING INFORMATION (FIGURE 1)

The derating information applicable to the contacts specified herein is shown in Figure 1.

### 1.5 PHYSICAL DIMENSIONS

The physical dimensions of the contacts specified herein are shown in Figure 2.

**TABLE 1(a) - TYPE VARIANTS**

Variant	Gender	Max. Weight (g)	Rear End
01	Male	2	Press-fit
02	Female	1.8	Press-fit

**TABLE 1(b) - MAXIMUM RATINGS**

No.	Characteristics	Symbol	Maximum Rating	Unit	Remarks
1	Rated Current	$I_{CR}$	40	A	Note 1
2	Operating Temperature Range	$T_{op}$	-55 to +125	°C	$T_{amb}$
3	Storage Temperature Range	$T_{stg}$	-65 to +125	°C	

**NOTES:**

- At  $T_{amb} \leq +60^{\circ}C$ . For derating at  $T_{amb} > +60^{\circ}C$ , see Figure 1.

**FIGURE 1 - PARAMETER DERATING INFORMATION**

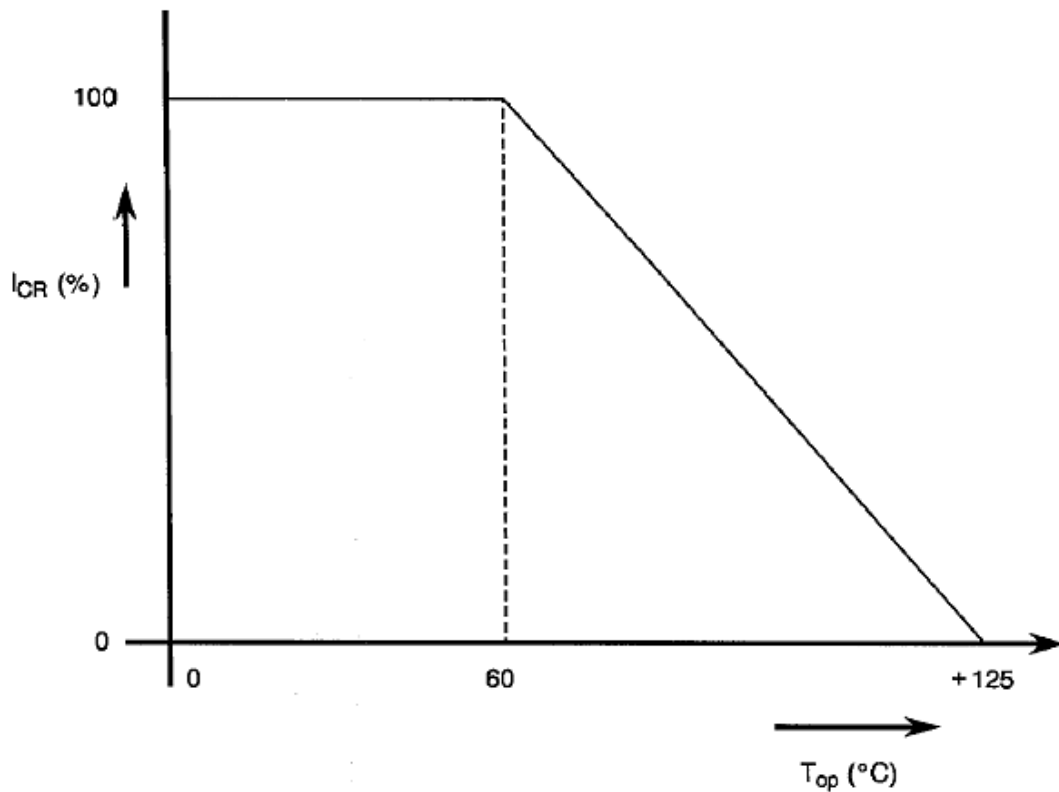

**Rated Contact Current versus Temperature**

**FIGURE 2 - PHYSICAL DIMENSIONS**

**FIGURE 2(a) – POWER PRESS-FIT CONTACTS, MALE AND FEMALE**

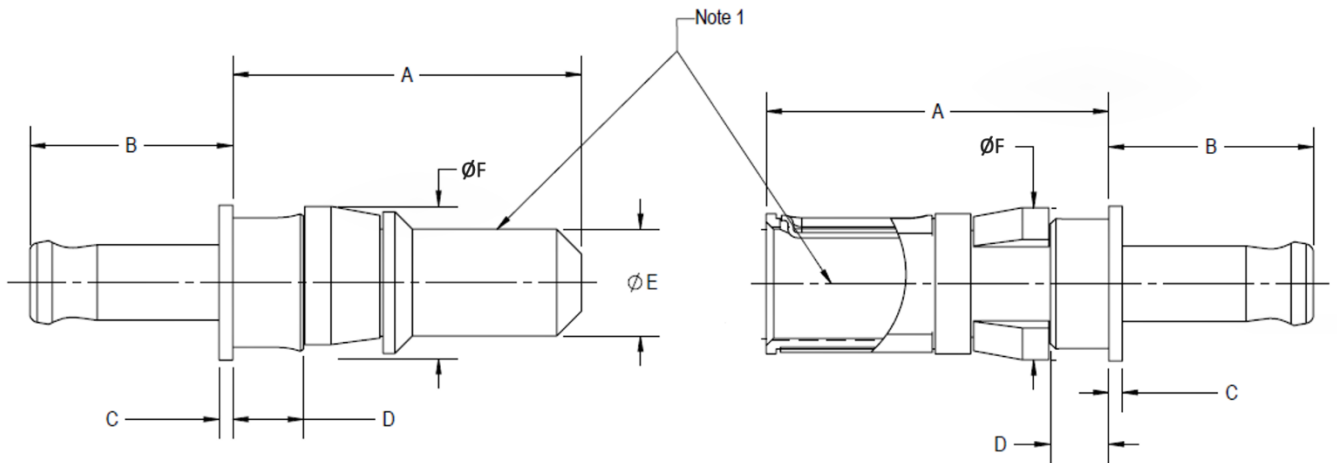

Variant	Contact Gender	A max.	B max.	C max.	D max.	ØE		ØF max.
						min.	max.	
01	Male	14	8	1	3	3.55	3.65	5.3
02	Female	14	8	1	3	-	-	5.3

**NOTES:**

1. Measurement point for plating thickness.
2. All dimensions are in millimetres.

**FIGURE 2(b) - PROTRUSION AND RECESS**

**MAXIMUM PROTRUSION OF CONTACTS RELATIVE TO REAR OF SHELL FLANGE**

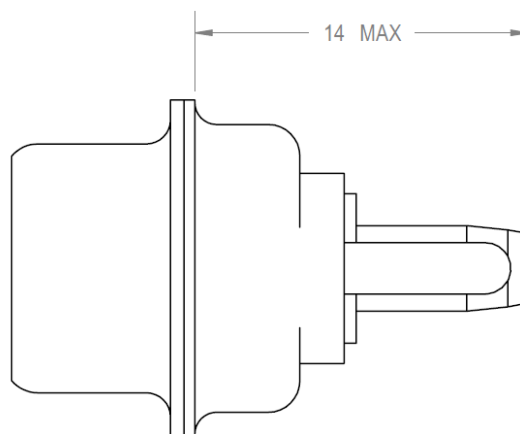



### MAXIMUM RECESS OF CONTACTS RELATIVE TO FRONT OF SHELL

Variant 01 (Male)

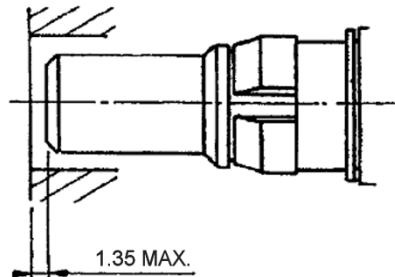

Variant 02 (Female)

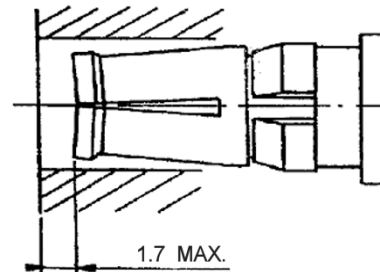

#### **NOTES:**

1. All dimensions are in millimetres.

## **2 APPLICABLE DOCUMENTS**

The following documents form part of this specification and shall be read in conjunction with it:

- (a) ESCC Generic Specification No. [3401](#) for Connectors, Electrical, Non-Filtered, Circular and Rectangular.
- (b) ESCC Detail Specification No. [3401/098](#), Connectors, Electrical, Rectangular, Non-removable Signal Press-fit Contacts and Removable Power Press-fit Contacts, Based on Types SDD, SND, SCBM.

## **3 TERMS, DEFINITIONS, ABBREVIATIONS, SYMBOLS AND UNITS**

For the purpose of this specification, the terms, definitions, abbreviations, symbols and units specified in ESCC Basic Specification No. [21300](#) shall apply.

## **4 REQUIREMENTS**

### **4.1 GENERAL**

The complete requirements for procurement of the contacts specified herein are stated in this specification and ESCC Generic Specification No. [3401](#). Deviations from the Generic Specification, applicable to this specification only, are detailed in Para. 4.2.

Deviations from the applicable Generic Specification and this Detail Specification, formally agreed with specific Manufacturers on the basis that the alternative requirements are equivalent to the ESCC requirements and do not affect the components' reliability, are listed in the appendices attached to this specification.

### **4.2 DEVIATIONS FROM GENERIC SPECIFICATION**

#### **4.2.1 Deviations from Special In-Process Controls**

None.

4.2.2 Deviations from Final Production Tests (Chart II)  
None.

4.2.3 Deviations from Burn-in and Electrical Measurements (Chart III)  
None (Chart III is not applicable).

4.2.4 Deviations from Qualification Tests (Chart IV)

- (a) Para. 9.10, Wiring: A Press-Fit Insertion Force Test shall be performed instead (see Para. 4.3.7 and ESCC Detail Specification No. [3401/098](#)).
- (b) Para. 9.15, Joint Strength: Not applicable.
- (c) Para. 9.29, Oversize Pin Exclusion: Not applicable.
- (d) Para. 9.30, Probe Damage: Not applicable.
- (e) Para. 9.31, Solderability: Not applicable.

4.2.5 Deviations from Lot Acceptance Tests (Chart V)

- (a) Para. 9.10, Wiring: A Press-Fit Insertion Force Test shall be performed instead (see Para. 4.3.7 and ESCC Detail Specification No. [3401/098](#)).
- (b) Para. 9.15, Joint Strength: Not applicable.
- (c) Para. 9.29, Oversize Pin Exclusion: Not applicable.
- (d) Para. 9.30, Probe Damage: Not applicable.

4.3 MECHANICAL REQUIREMENTS

4.3.1 Dimension Check  
The dimensions of the contacts specified herein shall be verified in accordance with the requirements set out in Para. 9.6 of ESCC Generic Specification No. [3401](#) and they shall conform to those shown in Figure 2 of this specification. Overall dimensions are specified with compatible inserts in ESCC Detail Specification No. [3401/098](#).

4.3.2 Weight  
The maximum weight of the contacts specified herein shall be as given in Table 1(a).

4.3.3 Contact Capability (Variant 02)  
For the purpose of this test, the pick-up and drop weights shall be as follows.

	Pick-Up Weight	Drop Weight
Weight (g)	85	567
Pin diameter (mm)	3.581 (+0.0025, -0)	3.632 (+0, -0.0025)
Insertion Depth (mm)	3.17	3.17

4.3.4 Contact Retention (in Insert)  
Contact retention within the insert shall be 40.86N. There shall be no displacement of the contact in excess of 0.3mm.

4.3.5 Contact Insertion and Withdrawal Forces  
The contact insertion and withdrawal forces shall be 65N maximum.

4.3.6 Engagement and Separation Forces (Variant 02)

The engagement and separation forces of the female contacts shall be as specified hereunder.

	Maximum Diameter Test Pin 3.632 (+0, -0.0025) mm	Minimum Diameter Test Pin 3.581 (+0.0025, -0) mm
Engagement Force (N)	6.87 max	0.83 min
Separation Force (N)	5.56 max	0.83 min

4.3.7 Press-fit Insertion Force

Receiving holes for press-fit terminations and the insertion force shall be as follows:

Contacts	Receiving Hole Diameter (mm)		Max. Insertion Force (N)
	Min.	Max.	
Gauge 8	2.97	3.07	500

4.4 MATERIALS AND FINISHES

The materials and finishes shall be as specified herein. Where a definite material is not specified, a material which will enable the contacts specified herein to meet the performance requirements of this specification shall be used. Acceptance or approval of any constituent material does not guarantee acceptance of the finished product.

4.4.1 Contact Body

The contacts shall be made of copper base alloy selected from raw materials with a minimum of impurities. Gold plating thickness shall be 1.27µm minimum over 1µm minimum of copper.

4.4.2 Retention Clip

The retention clips shall be made of copper base alloy selected from raw materials with a minimum of impurities. Gold plating thickness shall be 1.27µm minimum over 1µm minimum of copper.

4.4.3 Magnetism Level

As specified in ESCC Detail Specification No. [3401/098](#).

4.5 MARKING

4.5.1 General

The marking of all components delivered to this specification shall be in accordance with the requirements of ESCC Basic Specification No. [21700](#) and the following paragraphs.

Each component or the component's primary package shall be marked in respect of:

- (a) The ESCC qualified components symbol (for ESCC qualified components only).
- (b) The ESCC Component Number (see Para. 4.5.2).
- (c) Traceability Information.

The primary package shall also be marked with the delivered quantity of components.

4.5.2 The ESCC Component Number

The ESCC Component Number shall be constituted and marked as follows:

Example: 340109901B

- Detail Specification Reference: 3401099
- Component Type Variant Number: 01 (as required; see Table 1(a))
- Testing Level: B (mandatory)

4.5.3 Traceability Information

Traceability information shall be marked in accordance with the requirements of ESCC Basic Specification No. 21700.

4.6 ELECTRICAL MEASUREMENTS

4.6.1 Electrical Measurements at Room Temperature

The parameters to be measured in respect of electrical characteristics are scheduled in Table 2. Unless otherwise specified these measurements shall be performed at  $T_{amb} = +22 \pm 3^{\circ}C$ .

**TABLE 2 - ELECTRICAL MEASUREMENTS AT ROOM TEMPERATURE**

No.	Characteristics	Symbol	ESCC 3401 Test Method and Test Conditions	Limits		Unit
				Min	Max	
1	Low Level Contact Resistance	R <sub>CL</sub>	Para. 9.1.1.3	-	2.5	mΩ
2	Rated Current Contact Resistance	R <sub>CR</sub>	Para. 9.1.1.3 40A	-	2	mΩ

4.7 ENVIRONMENTAL AND ENDURANCE TESTS

4.7.1 Measurements and Inspections on Completion of Environmental Tests

The parameters to be measured and inspections to be performed on completion of environmental tests are scheduled in Table 6. Unless otherwise specified, the measurements shall be performed at  $T_{amb} = +22 \pm 3^{\circ}C$ .

4.7.2 Measurements and Inspections on Completion of Endurance Tests

The parameters to be measured and inspections to be performed on completion of endurance tests shall be those specified in Table 6. Unless otherwise specified, these measurements shall be performed at  $T_{amb} = +22 \pm 3^{\circ}C$ .

4.7.3 Conditions for High Temperature Storage Test (Part of Endurance Testing)

The requirements for the high temperature storage test are specified in Section 9 of ESCC Generic Specification No. 3401. The conditions for high temperature storage testing shall be the maximum storage temperature specified in Table 1(b) of this specification.

**TABLE 6 - MEASUREMENTS AND INSPECTIONS ON COMPLETION OF ENVIRONMENTAL AND ENDURANCE TESTING**

No.	ESCC Generic Spec. No. 3401		Measurements and Inspections		Symbol	Limits		Unit
	Environmental and Endurance Tests (1)	Test Methods and Conditions	Identification	Conditions		Min	Max	
01	Wiring	Paras. 4.2.4, 4.2.5 and 4.3.7 of this Spec.	Press-fit Insertion Force	Para. 4.3.7 of this Spec.	-	Para. 4.3.7 of this Spec.		-
			<b>Final Measurements</b>					
			Low Level Contact Resistance	Table 2 Item 1	R <sub>CL</sub>	-	2.5	mΩ
			Rated Current Contact Resistance	Table 2 Item 2	R <sub>CR</sub>	-	2	mΩ
02	Vibration	Para. 9.11	ESCC 3401/098	-	-	-	-	-
03	Shock or Bump	Para. 9.12	ESCC 3401/098	-	-	-	-	-
04	Climatic Sequence	Para. 9.13	ESCC 3401/098	-	-	-	-	-
05	Plating Thickness	Para. 9.14 and Para. 4.4.1 of this Spec.	Thickness	Para. 4.4.1 of this Spec.	-	Para. 4.4.1 of this Spec.		-
06	Rapid Change of Temperature	Para. 9.16	ESCC 3401/098	-	-	-	-	-
07	Contact Retention (in Insert)	Para. 9.17 and Para. 4.3.4 of this Spec.	Contact Displacement	Para. 4.3.4 of this Spec.	-	Para. 4.3.4 of this Spec.		-
08	Endurance	Para. 9.18	<b>Initial Measurement</b>					
			Low Level Contact Resistance	Table 2 Item 1	R <sub>CL</sub>	-	2.5	mΩ
			<b>Final Inspection</b>					
			Visual Examination	-	-	-	-	-
			<b>Final Measurement</b>					
			Low Level Contact Resistance Drift	Table 2 Item 1	ΔR <sub>CL</sub>	-	0.5	mΩ
09	High Temperature Storage	Para. 9.21	<b>Initial</b>					
			Low Level Contact Resistance	Table 2 Item 1	R <sub>CL</sub>	-	2.5	mΩ
			<b>Final Inspection</b>					
			Visual Examination	-	-	-	-	-
			<b>Final Measurement</b>					
			Low Level Contact Resistance Drift	Table 2 Item 1	ΔR <sub>CL</sub>	-	0.5	mΩ
			Rated Current Contact Resistance	Table 2 Item 2	R <sub>CR</sub>	-	2	mΩ
			Contact Retention (in Insert)	Para. 4.3.4 of this Spec.	-	Para. 4.3.4 of this Spec.		-
10	Corrosion	Para. 9.22	ESCC 3401/098	-	-	-	-	-
11	High Temperature Measurements	Para. 9.25	ESCC 3401/098	-	-	-	-	-

No.	ESCC Generic Spec. No. 3401		Measurements and Inspections		Symbol	Limits		Unit
	Environmental and Endurance Tests (1)	Test Methods and Conditions	Identification	Conditions		Min	Max	
12	Overload Test	Para. 9.26	Rated Current Contact Resistance	Table 2 item 2	R <sub>CR</sub>	-	2	mΩ
13	Maintenance Aging	Para. 9.27	<b>Final Measurements</b> Contact Retention (in Insert) Contact Insertion & Withdrawal Forces	Para. 4.3.4 of this Spec. Para. 4.3.5 of this Spec.	- -	Para. 4.3.4 of this Spec. Para. 4.3.5 of this Spec.	- -	- -
14	Engagement and Separation Forces	Para. 9.28 and para. 4.3.6 of this Spec.	Force	-	-	Para. 4.3.6 of this Spec.	-	-

**NOTES:**

1. The tests in this table refer to either Chart IV or V and shall be used as applicable.