



**INTEGRATED CIRCUITS, SILICON MONOLITHIC, CMOS
8-BIT PRIORITY ENCODER WITH FULLY BUFFERED
OUTPUTS**

BASED ON TYPE 4532B

ESCC Detail Specification No. 9202/065

Issue 5	August 2020
---------	-------------



LEGAL DISCLAIMER AND COPYRIGHT

European Space Agency, Copyright © 2020. All rights reserved.

The European Space Agency disclaims any liability or responsibility, to any person or entity, with respect to any loss or damage caused, or alleged to be caused, directly or indirectly by the use and application of this ESCC publication.

This publication, without the prior permission of the European Space Agency and provided that it is not used for a commercial purpose, may be:

- copied in whole, in any medium, without alteration or modification.
- copied in part, in any medium, provided that the ESCC document identification, comprising the ESCC symbol, document number and document issue, is removed.

DOCUMENTATION CHANGE NOTICE

(Refer to <https://escies.org> for ESCC DCR content)

DCR No.	CHANGE DESCRIPTION
1185 , 1200 , 1258	Specification updated to incorporate changes per DCR.

TABLE OF CONTENTS

1	GENERAL	5
1.1	SCOPE	5
1.2	APPLICABLE DOCUMENTS	5
1.3	TERMS, DEFINITIONS, ABBREVIATIONS, SYMBOLS AND UNITS	5
1.4	THE ESCC COMPONENT NUMBER AND COMPONENT TYPE VARIANTS	5
1.4.1	The ESCC Component Number	5
1.4.2	Component Type Variants	5
1.5	MAXIMUM RATINGS	6
1.6	HANDLING PRECAUTIONS	6
1.7	PHYSICAL DIMENSIONS AND TERMINAL IDENTIFICATION	7
1.7.1	Flat Package (FP) - 16 Pin	7
1.7.2	Dual-in-line Package (DIP) - 16 Pin	8
1.7.3	Notes to Physical Dimensions and Terminal Identification for Packaged Components	9
1.7.4	Die (Variant 12)	10
1.8	FUNCTIONAL DIAGRAM	11
1.9	PIN/PAD ASSIGNMENT	11
1.10	TRUTH TABLE	12
1.11	INPUT PROTECTION NETWORK	12
2	REQUIREMENTS	13
2.1	GENERAL	13
2.1.1	Deviations from the Generic Specification	13
2.2	MARKING	13
2.3	ELECTRICAL MEASUREMENTS AT ROOM, HIGH AND LOW TEMPERATURES	13
2.3.1	Room Temperature Electrical Measurements	13
2.3.2	High and Low Temperatures Electrical Measurements	17
2.3.3	Notes to Electrical Measurement Tables	19
2.4	PARAMETER DRIFT VALUES	21
2.5	INTERMEDIATE AND END-POINT ELECTRICAL MEASUREMENTS	21
2.6	HIGH TEMPERATURE REVERSE BIAS BURN-IN CONDITIONS	22
2.6.1	N-Channel HTRB	22
2.6.2	P-Channel HTRB	23
2.7	POWER BURN-IN CONDITIONS	23
2.8	OPERATING LIFE CONDITIONS	23
	APPENDIX 'A'	24

1 GENERAL

1.1 SCOPE

This specification details the ratings, physical and electrical characteristics and test and inspection data for the component type variants and/or the range of components specified below. It supplements the requirements of, and shall be read in conjunction with, the ESCC Generic Specification listed under Applicable Documents.

1.2 APPLICABLE DOCUMENTS

The following documents form part of this specification and shall be read in conjunction with it:

- (a) ESCC Generic Specification No. [9000](#)
- (b) [MIL-STD-883](#), Test Methods and Procedures for Microelectronics

1.3 TERMS, DEFINITIONS, ABBREVIATIONS, SYMBOLS AND UNITS

For the purpose of this specification, the terms, definitions, abbreviations, symbols and units specified in ESCC Basic Specification No. [21300](#) shall apply.

1.4 THE ESCC COMPONENT NUMBER AND COMPONENT TYPE VARIANTS

1.4.1 The ESCC Component Number

The ESCC Component Number shall be constituted as follows:

Example: 920206501

- Detail Specification Reference: 9202065
- Component Type Variant Number: 01 (as required)

1.4.2 Component Type Variants

The component type variants applicable to this specification are as follows:

Variant Number	Based on Type	Case	Terminal Material and Finish	Weight max g
01	4532B	FP	G2	0.7
02	4532B	FP	G4	0.7
08	4532B	DIP	G2	2.2
09	4532B	DIP	G4	2.2
12	4532B	Die	N/A	N/A

The terminal material and finish shall be in accordance with the requirements of ESCC Basic Specification No. [23500](#).

1.5 MAXIMUM RATINGS

The maximum ratings shall not be exceeded at any time during use or storage.

Maximum ratings shall only be exceeded during testing to the extent specified in this specification and when stipulated in Test Methods and Procedures of the ESCC Generic Specification.

Characteristics	Symbols	Maximum Ratings	Units	Remarks
Supply Voltage	V_{DD}	-0.5 to 18	V	Note 1
Input Voltage	V_{IN}	-0.5 to $V_{DD}+0.5$	V	Note 1 Power on
Input Current	I_{IN}	± 10	mA	-
Device Power Dissipation (Continuous)	P_D	200	mW	-
Power Dissipation per Output	P_{DSO}	100	mW	-
Operating Temperature Range	T_{op}	-55 to +125	°C	T_{amb}
Storage Temperature Range	T_{stg}	-65 to +150	°C	-
Soldering Temperature	T_{sol}	+265	°C	Note 2

NOTES:

1. Device is functional for $3V \leq V_{DD} \leq 15V$.
2. Duration 10 seconds maximum at a distance of not less than 1.5mm from the device body and the same terminal shall not be resoldered until 3 minutes have elapsed.

1.6 HANDLING PRECAUTIONS

These devices are susceptible to damage by electrostatic discharge. Therefore, suitable precautions shall be employed for protection during all phases of manufacture, testing, packaging, shipment and any handling.

These components are categorised as Class 1 per ESCC Basic Specification No. [23800](#) with a minimum Critical Path Failure Voltage of 400 Volts.

1.7 PHYSICAL DIMENSIONS AND TERMINAL IDENTIFICATION

Consolidated Notes for Packaged Components are given in Para. 1.7.3.

1.7.1 Flat Package (FP) - 16 Pin (Variants 01, 02)

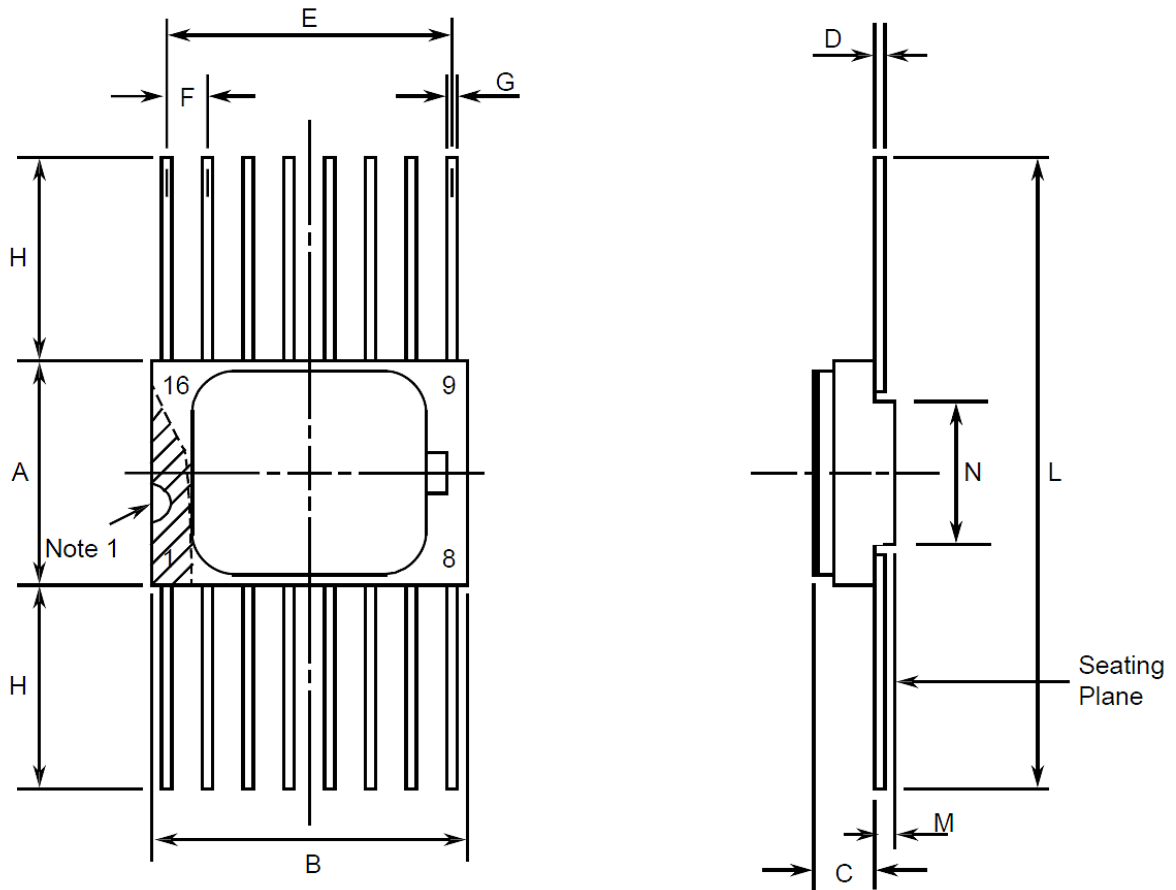

Symbols	Dimensions mm		Notes
	Min	Max	
A	6.75	7.06	
B	9.76	10.14	
C	1.49	1.95	
D	0.1	0.15	5
E	8.76	9.01	
F	1.27 BSC		3, 6
G	0.38	0.48	5
H	6	-	5
L	18.75	22	
M	0.33	0.43	
N	4.32 TYPICAL		

1.7.2 Dual-in-line Package (DIP) - 16 Pin (Variants 08, 09)

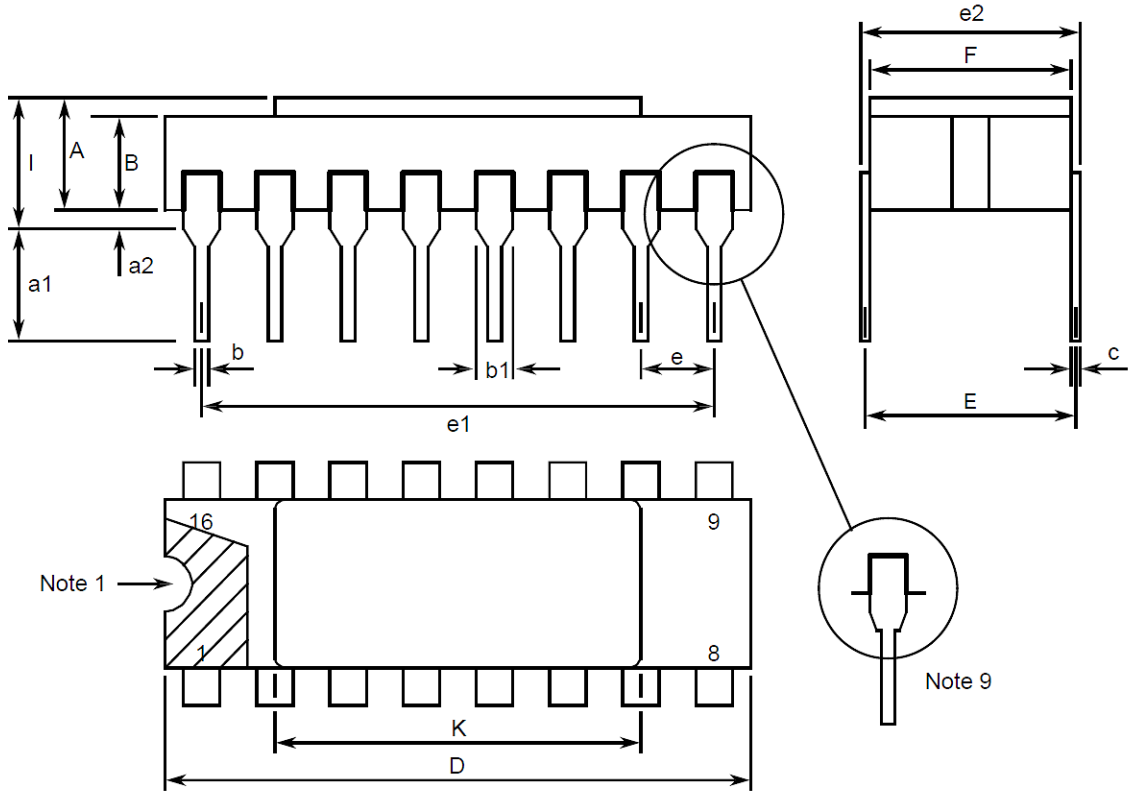

Symbols	Dimensions mm		Notes
	Min	Max	
A	2.1	2.71	
a1	3	3.7	
a2	0.63	1.14	2
B	1.82	2.39	
b	0.4	0.5	5
b1	1.14	1.5	5
c	0.2	0.3	5
D	20.06	20.58	
E	7.36	7.87	
e	2.54 BSC		4, 6
e1	17.65	17.9	
e2	7.62	8.12	
F	7.29	7.7	
I	-	3.83	

Symbols	Dimensions mm		Notes
	Min	Max	
K	10.9	12.1	

1.7.3 Notes to Physical Dimensions and Terminal Identification for Packaged Components

1. Index area; a notch or a dot shall be located adjacent to Pin 1 and shall be within the shaded area shown. For chip carrier packages, the index shall be as shown.
2. The dimension shall be measured from the seating plane to the base plane.
3. The true position pin spacing is 1.27mm between centrelines. Each pin centreline shall be located within ± 0.13 mm of its true longitudinal position relative to Pin 1 and the highest pin number.
4. The true position pin spacing is 2.54mm between centrelines. Each pin centreline shall be located within ± 0.25 mm of its true longitudinal position relative to Pin 1 and the highest pin number.
5. All terminals.
6. 14 spaces.
9. For all pins, either pin shape may be supplied.

1.7.4 Die (Variant 12)

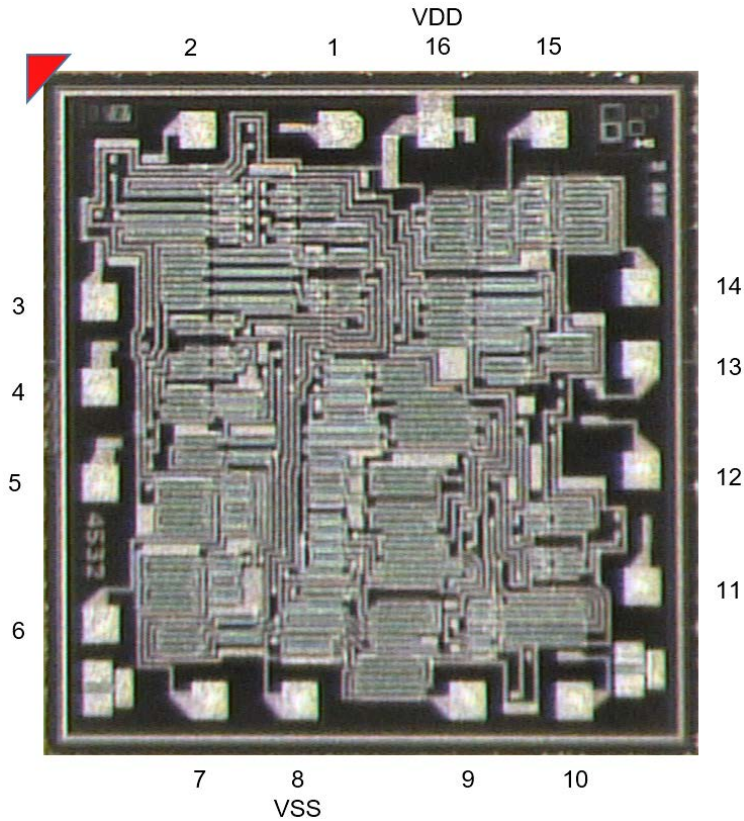

NOTES:

1. Die materials and dimensions:
 - Die substrate: Silicon
 - Die length and width: 1.93mm x 1.85mm
 - Die thickness: 525 ±25µm
 - Passivation: P. Vapox: 800nm ±160nm
 - Top metallisation: Al (99%)/Si (1%) with thickness: 1.1 ±0.1µm
 - Backside metallisation: N/A (i.e. bare silicon)
 - Bond pad dimensions: 90µm x 90µm (typ.)
2. Terminal identification and die orientation are indicated by the die mask (including the die reference, i.e. 4532) and pad numbers as shown; see Para. 1.9.
3. Bias details: backside contact = V_{DD}
4. Die packaging orientation: The die corner highlighted with the red triangle is positioned in the waffle pack as follows:

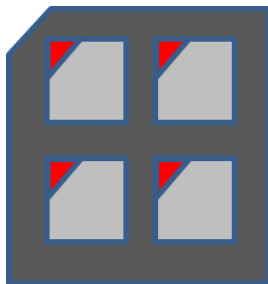

1.8 FUNCTIONAL DIAGRAM

Pin/Pad numbers relate to FP, DIP packages and Die.

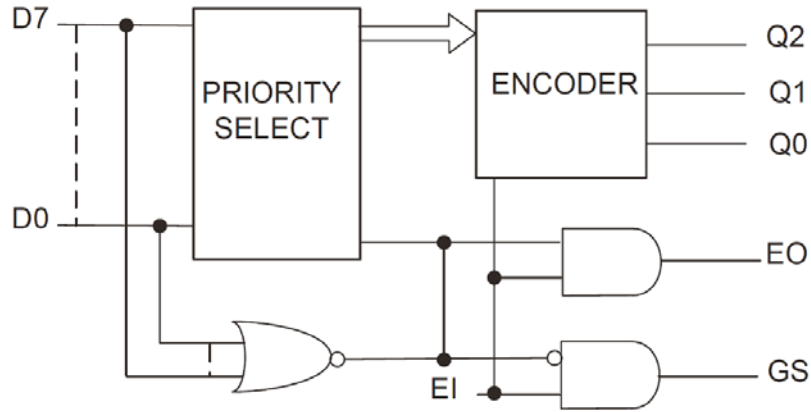

NOTES:

1. The package lid for all packages is not connected to any terminal.

1.9 PIN/PAD ASSIGNMENT

Pin/Pad	Function	Pin/Pad	Function
1	D4 Input	9	Q0 Output
2	D5 Input	10	D0 Input
3	D6 Input	11	D1 Input
4	D7 Input	12	D2 Input
5	EI Input (Enable Input)	13	D3 Input
6	Q2 Output	14	GS Output (Group Select)
7	Q1 Output	15	EO Output (Enable Output)
8	V _{SS}	16	V _{DD}

1.10 TRUTH TABLE

1. Logic Level Definitions: L = Low Level, H = High Level, X = Irrelevant.

INPUTS									OUTPUTS				
EI	D7	D6	D5	D4	D3	D2	D1	D0	GS	Q2	Q1	Q0	EO
L	X	X	X	X	X	X	X	X	L	L	L	L	L
H	L	L	L	L	L	L	L	L	L	L	L	L	H
H	H	X	X	X	X	X	X	X	H	H	H	H	L
H	L	H	X	X	X	X	X	X	H	H	H	L	L
H	L	L	H	X	X	X	X	X	H	H	L	H	L
H	L	L	L	H	X	X	X	X	H	H	L	L	L
H	L	L	L	L	H	X	X	X	H	L	H	H	L
H	L	L	L	L	L	H	X	X	H	L	H	L	L
H	L	L	L	L	L	L	H	X	H	L	L	H	L
H	L	L	L	L	L	L	L	H	H	L	L	L	L

1.11 INPUT PROTECTION NETWORK
(CONTROL INPUTS)

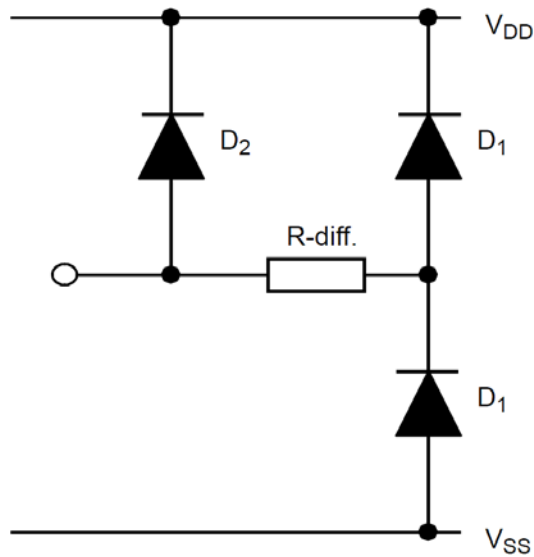

2 REQUIREMENTS

2.1 GENERAL

The complete requirements for procurement of the components specified herein are as stated in this specification and the ESCC Generic Specification. Permitted deviations from the Generic Specification, applicable to this specification only, are listed below.

Permitted deviations from the Generic Specification and this Detail Specification, formally agreed with specific Manufacturers on the basis that the alternative requirements are equivalent to the ESCC requirement and do not affect the component's reliability, are listed in the appendices attached to this specification.

2.1.1 Deviations from the Generic Specification

None.

2.2 MARKING

The marking shall be in accordance with the requirements of ESCC Basic Specification No. 21700 and as follows.

The information to be marked on the component or its primary package shall be:

- (a) Terminal identification (see Para. 1.7).
- (b) The ESCC qualified components symbol (for ESCC qualified components only).
- (c) The ESCC Component Number (see Para. 1.4.1).
- (d) Traceability information.

2.3 ELECTRICAL MEASUREMENTS AT ROOM, HIGH AND LOW TEMPERATURES

Electrical measurements shall be performed at room, high and low temperatures. Consolidated Notes are given in Para. 2.3.3.

2.3.1 Room Temperature Electrical Measurements

The measurements shall be performed at $T_{amb} = +22 \pm 3^{\circ}C$.

Characteristics	Symbols	MIL-STD-883 Test Method	Test Conditions Note 1	Limits		Units
				Min	Max	
Functional Test 1	-	3014	Verify Truth Table without Load $V_{IL} = 0V, V_{IH} = 3V$ $V_{DD} = 3V, V_{SS} = 0V$ Note 2	-	-	-
Functional Test 2	-	3014	Verify Truth Table without Load $V_{IL} = 0V, V_{IH} = 15V$ $V_{DD} = 15V, V_{SS} = 0V$ Note 2	-	-	-
Quiescent Current	I_{DD}	3005	$V_{IL} = 0V, V_{IH} = 15V$ $V_{DD} = 15V, V_{SS} = 0V$ Note 3	-	1	μA

Characteristics	Symbols	MIL-STD-883 Test Method	Test Conditions Note 1	Limits		Units
				Min	Max	
Low Level Input Current	I _{IL}	3009	V _{IN} (Under Test) = 0V V _{DD} = 15V, V _{SS} = 0V	-	-50	nA
High Level Input Current	I _{IH}	3010	V _{IN} (Under Test) = 15V V _{DD} = 15V, V _{SS} = 0V	-	50	nA
Low Level Output Voltage 1	V _{OL1}	3007	V _{IL} = 0V, V _{IH} = 15V, I _{OL} = 0A V _{DD} = 15V, V _{SS} = 0V	-	50	mV
Low Level Output Voltage 2 (Noise Immunity)	V _{OL2}	3007	V _{IL} = 1.5V, V _{IH} = 3.5V, I _{OL} = 0A V _{DD} = 5V, V _{SS} = 0V	-	500	mV
Low Level Output Voltage 3 (Noise Immunity)	V _{OL3}	3007	V _{IL} = 4V, V _{IH} = 11V, I _{OL} = 0A V _{DD} = 15V, V _{SS} = 0V	-	1.5	V
High Level Output Voltage 1	V _{OH1}	3006	V _{IL} = 0V, V _{IH} = 15V, I _{OH} = 0A V _{DD} = 15V, V _{SS} = 0V	14.95	-	V
High Level Output Voltage 2 (Noise Immunity)	V _{OH2}	3006	V _{IL} = 1.5V, V _{IH} = 3.5V, I _{OH} = 0A V _{DD} = 5V, V _{SS} = 0V	4.5	-	V
High Level Output Voltage 3 (Noise Immunity)	V _{OH3}	3006	V _{IL} = 4V, V _{IH} = 11V, I _{OH} = 0A V _{DD} = 15V, V _{SS} = 0V	13.5	-	V
Low Level Output Current 1	I _{OL1}	-	V _{IL} = 0V, V _{IH} = 5V, V _{OL} = 0.4V V _{DD} = 5V, V _{SS} = 0V Note 4	510	-	μA
Low Level Output Current 2	I _{OL2}	-	V _{IL} = 0V, V _{IH} = 15V, V _{OL} = 1.5V V _{DD} = 15V, V _{SS} = 0V Note 4	3.4	-	mA
High Level Output Current 1	I _{OH1}	-	V _{IL} = 0V, V _{IH} = 5V, V _{OH} = 4.6V V _{DD} = 5V, V _{SS} = 0V Note 4	-510	-	μA
High Level Output Current 2	I _{OH2}	-	V _{IL} = 0V, V _{IH} = 15V, V _{OH} = 13.5V V _{DD} = 15V, V _{SS} = 0V Note 4	-3.4	-	mA
Threshold Voltage N-Channel	V _{THN}	-	D1 Input at Ground All Other Inputs: V _{IN} = 5V V _{DD} = 5V, I _{SS} = -10μA	-0.7	-3	V
Threshold Voltage P-Channel	V _{THP}	-	D1 Input at Ground All Other Inputs: V _{IN} = -5V V _{SS} = -5V, I _{DD} = 10μA	0.7	3	V
Input Clamp Voltage 1, to V _{SS}	V _{IC1}	-	I _{IN} (Under Test) = -100μA V _{DD} = Open, V _{SS} = 0V All Other Pins Open	-	-2	V

Characteristics	Symbols	MIL-STD-883 Test Method	Test Conditions Note 1	Limits		Units
				Min	Max	
Input Clamp Voltage 2, to V _{DD}	V _{IC2}	-	V _{IN} (Under Test) = 6V R = 30kΩ, V _{SS} = Open All Other Pins Open Note 5	3	-	V
Input Capacitance	C _{IN}	3012	V _{IN} (Not Under Test) = 0V V _{DD} = V _{SS} = 0V f = 100 kHz to 1 MHz Note 6	-	7.5	pF
Propagation Delay Low to High, D7 to Q0	t _{PLH1}	3003	V _{IN} (Under Test) = Pulse Generator V _{IN} (Remaining Inputs) = Truth Table V _{IL} = 0V, V _{IH} = 5V, V _{DD} = 5V, V _{SS} = 0V Note 7	-	390	ns
Propagation Delay High to Low, D7 to Q0	t _{PHL1}	3003	V _{IN} (Under Test) = Pulse Generator V _{IN} (Remaining Inputs) = Truth Table V _{IL} = 0V, V _{IH} = 5V, V _{DD} = 5V, V _{SS} = 0V Note 7	-	390	ns
Propagation Delay Low to High, E1 to EO	t _{PLH2}	3003	V _{IN} (Under Test) = Pulse Generator V _{IN} (Remaining Inputs) = Truth Table V _{IL} = 0V, V _{IH} = 5V, V _{DD} = 5V, V _{SS} = 0V Note 7	-	220	ns
Propagation Delay High to Low, E1 to EO	t _{PHL2}	3003	V _{IN} (Under Test) = Pulse Generator V _{IN} (Remaining Inputs) = Truth Table V _{IL} = 0V, V _{IH} = 5V, V _{DD} = 5V, V _{SS} = 0V Note 7	-	220	ns
Propagation Delay Low to High, E1 to GS	t _{PLH3}	3003	V _{IN} (Under Test) = Pulse Generator V _{IN} (Remaining Inputs) = Truth Table V _{IL} = 0V, V _{IH} = 5V, V _{DD} = 5V, V _{SS} = 0V Note 7	-	220	ns
Propagation Delay High to Low, E1 to GS	t _{PHL3}	3003	V _{IN} (Under Test) = Pulse Generator V _{IN} (Remaining Inputs) = Truth Table V _{IL} = 0V, V _{IH} = 5V, V _{DD} = 5V, V _{SS} = 0V Note 7	-	220	ns

Characteristics	Symbols	MIL-STD-883 Test Method	Test Conditions Note 1	Limits		Units
				Min	Max	
Propagation Delay Low to High, EI to Q0	t _{PLH4}	3003	V _{IN} (Under Test) = Pulse Generator V _{IN} (Remaining Inputs) = Truth Table V _{IL} = 0V, V _{IH} = 5V, V _{DD} = 5V, V _{SS} = 0V Note 7	-	290	ns
Propagation Delay High to Low, EI to Q0	t _{PHL4}	3003	V _{IN} (Under Test) = Pulse Generator V _{IN} (Remaining Inputs) = Truth Table V _{IL} = 0V, V _{IH} = 5V, V _{DD} = 5V, V _{SS} = 0V Note 7	-	290	ns
Propagation Delay Low to High, D7 to GS	t _{PLH5}	3003	V _{IN} (Under Test) = Pulse Generator V _{IN} (Remaining Inputs) = Truth Table V _{IL} = 0V, V _{IH} = 5V, V _{DD} = 5V, V _{SS} = 0V Note 7	-	290	ns
Propagation Delay High to Low, D7 to GS	t _{PHL5}	3003	V _{IN} (Under Test) = Pulse Generator V _{IN} (Remaining Inputs) = Truth Table V _{IL} = 0V, V _{IH} = 5V, V _{DD} = 5V, V _{SS} = 0V Note 7	-	290	ns
Transition Time Low to High, EO	t _{TLH}	3004	V _{IN} (Under Test) = Pulse Generator V _{IN} (Remaining Inputs) = Truth Table V _{IL} = 0V, V _{IH} = 5V, V _{DD} = 5V, V _{SS} = 0V Note 7	-	150	ns
Transition Time High to Low, EO	t _{THL}	3004	V _{IN} (Under Test) = Pulse Generator V _{IN} (Remaining Inputs) = Truth Table V _{IL} = 0V, V _{IH} = 5V, V _{DD} = 5V, V _{SS} = 0V Note 7	-	150	ns

2.3.2 High and Low Temperatures Electrical Measurements

The measurements shall be performed at $T_{amb} = +125 (+0 -5)^{\circ}C$ and $T_{amb} = -55 (+5 -0)^{\circ}C$.

Characteristics	Symbols	MIL-STD-883 Test Method	Test Conditions Note 1	Limits		Units
				Min	Max	
Functional Test 1	-	3014	Verify Truth Table without Load $V_{IL} = 0V, V_{IH} = 3V$ $V_{DD} = 3V, V_{SS} = 0V$ Note 2	-	-	-
Functional Test 2	-	3014	Verify Truth Table without Load $V_{IL} = 0V, V_{IH} = 15V$ $V_{DD} = 15V, V_{SS} = 0V$ Note 2	-	-	-
Quiescent Current	I_{DD}	3005	$V_{IL} = 0V, V_{IH} = 15V$ $V_{DD} = 15V, V_{SS} = 0V$ Note 3 $T_{amb} = +125^{\circ}C$ $T_{amb} = -55^{\circ}C$	- -	30 1	μA
Low Level Input Current	I_{IL}	3009	V_{IN} (Under Test) = 0V $V_{DD} = 15V, V_{SS} = 0V$ $T_{amb} = +125^{\circ}C$ $T_{amb} = -55^{\circ}C$	- -	-100 -50	nA
High Level Input Current	I_{IH}	3010	V_{IN} (Under Test) = 15V $V_{DD} = 15V, V_{SS} = 0V$ $T_{amb} = +125^{\circ}C$ $T_{amb} = -55^{\circ}C$	- -	100 50	nA
Low Level Output Voltage 1	V_{OL1}	3007	$V_{IL} = 0V, V_{IH} = 15V,$ $I_{OL} = 0A$ $V_{DD} = 15V, V_{SS} = 0V$	-	50	mV
Low Level Output Voltage 2 (Noise Immunity)	V_{OL2}	3007	$V_{IL} = 1.5V, V_{IH} = 3.5V,$ $I_{OL} = 0A$ $V_{DD} = 5V, V_{SS} = 0V$	-	500	mV
Low Level Output Voltage 3 (Noise Immunity)	V_{OL3}	3007	$V_{IL} = 4V, V_{IH} = 11V,$ $I_{OL} = 0A$ $V_{DD} = 15V, V_{SS} = 0V$	-	1.5	V
High Level Output Voltage 1	V_{OH1}	3006	$V_{IL} = 0V, V_{IH} = 15V,$ $I_{OH} = 0A$ $V_{DD} = 15V, V_{SS} = 0V$	14.95	-	V
High Level Output Voltage 2 (Noise Immunity)	V_{OH2}	3006	$V_{IL} = 1.5V, V_{IH} = 3.5V,$ $I_{OH} = 0A$ $V_{DD} = 5V, V_{SS} = 0V$	4.5	-	V
High Level Output Voltage 3 (Noise Immunity)	V_{OH3}	3006	$V_{IL} = 4V, V_{IH} = 11V,$ $I_{OH} = 0A$ $V_{DD} = 15V, V_{SS} = 0V$	13.5	-	V

Characteristics	Symbols	MIL-STD-883 Test Method	Test Conditions Note 1	Limits		Units
				Min	Max	
Low Level Output Current 1	I _{OL1}	-	V _{IL} = 0V, V _{IH} = 5V, V _{OL} = 0.4V V _{DD} = 5V, V _{SS} = 0V Note 4 T _{amb} = +125°C T _{amb} = -55°C	360 640	- -	μA
Low Level Output Current 2	I _{OL2}	-	V _{IL} = 0V, V _{IH} = 15V, V _{OL} = 1.5V V _{DD} = 15V, V _{SS} = 0V Note 4 T _{amb} = +125°C T _{amb} = -55°C	2.4 4.2	- -	mA
High Level Output Current 1	I _{OH1}	-	V _{IL} = 0V, V _{IH} = 5V, V _{OH} = 4.6V V _{DD} = 5V, V _{SS} = 0V Note 4 T _{amb} = +125°C T _{amb} = -55°C	-360 -640	- -	μA
High Level Output Current 2	I _{OH2}	-	V _{IL} = 0V, V _{IH} = 15V, V _{OH} = 13.5V V _{DD} = 15V, V _{SS} = 0V Note 4 T _{amb} = +125°C T _{amb} = -55°C	-2.4 -4.2	- -	mA
Threshold Voltage N-Channel	V _{THN}	-	D1 Input at Ground All Other Inputs: V _{IN} = 5V V _{DD} = 5V, I _{SS} = -10μA T _{amb} = +125°C T _{amb} = -55°C	-0.3 -0.7	-3.5 -3.5	V
Threshold Voltage P-Channel	V _{THP}	-	D1 Input at Ground All Other Inputs: V _{IN} = -5V V _{SS} = -5V, I _{DD} = 10μA T _{amb} = +125°C T _{amb} = -55°C	0.3 0.7	3.5 3.5	V

2.3.3 Notes to Electrical Measurement Tables

1. Unless otherwise specified all inputs and outputs shall be tested for each characteristic, inputs not under test shall be $V_{IN} = V_{SS}$ or V_{DD} and outputs not under test shall be open.
2. Functional tests shall be performed to verify Truth Table with $V_{OH} \geq V_{DD}-0.5V$, $V_{OL} \leq 0.5V$. The maximum time to output comparator strobe = 300 μ s.
3. Quiescent Current shall be tested using the following input conditions where 1 = V_{IH} and 0 = V_{IL} :

I _{DD} Test	Input Pattern No.	Input Conditions								
		D0	D1	D2	D3	D4	D5	D6	D7	EI
(a)	1	0	0	0	0	0	0	0	0	0
	2	0	0	0	0	0	0	0	0	1
	3	1	0	0	0	0	0	0	0	1
(b)	4	1	1	0	0	0	0	0	0	1
(c)	5	0	1	0	0	0	0	0	0	1
(d)	6	1	1	1	0	0	0	0	0	1
(e)	7	0	0	1	0	0	0	0	0	1
(f)	8	0	0	0	1	0	0	0	0	1
(g)	9	1	1	1	1	1	0	0	0	1
(h)	10	0	0	0	0	1	0	0	0	1
(i)	11	0	0	0	0	0	1	0	0	1
(j)	12	0	0	0	0	0	0	1	0	1
	13	1	1	1	1	1	1	1	1	1
(k)	14	0	0	0	0	0	0	0	1	1
	15	1	1	1	1	1	1	1	1	0
(l)	16	0	1	0	0	1	0	0	0	1
(m)	17	1	0	1	1	0	0	0	0	1
(n)	18	0	0	1	0	1	1	0	0	1
(o)	19	1	0	1	0	1	0	1	1	1
(p)	20	0	1	1	1	0	1	0	0	0
(q)	21	1	1	0	1	1	1	0	1	1
(r)	22	1	1	0	1	0	1	1	0	1

4. Interchange of forcing and measuring parameters is permitted.

5. Input Clamp Voltage 2 to V_{DD} , V_{IC2} , shall be tested on each input as follows:

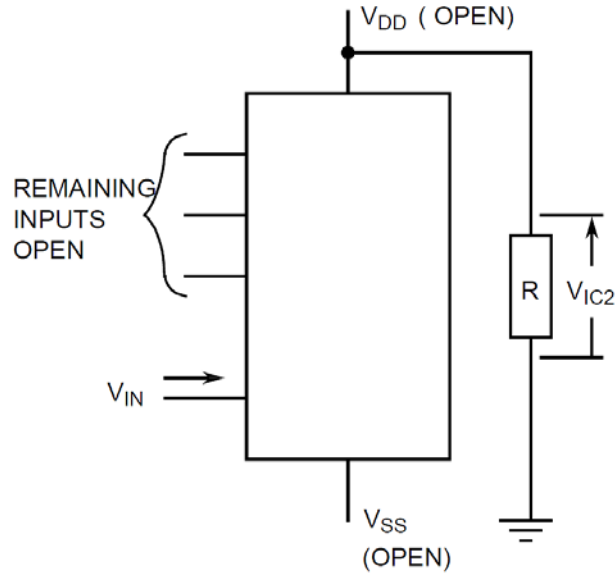

6. Guaranteed but not tested.
7. For Packaged Components (Variants 01, 02, 08, 09), read and record measurements shall be performed on a sample of 32 components with 0 failures permitted.
- For Die Components (Variant 12), read and record measurements shall be performed on a sample of 32 components or 100% of the Packaged Test Sublot, whichever is less, with 0 failures permitted.

The pulse generator shall have the following characteristics:

$V_{GEN} = 0$ to V_{DD} ; $f_{GEN} = 500\text{kHz}$; t_r and $t_f \leq 15\text{ns}$ (10% to 90%); duty cycle = 50%; $Z_{out} = 50\Omega$. Output load capacitance $C_L = 50\text{pF} \pm 5\%$ including scope probe, wiring and stray capacitance without component in the test fixture. Channel bias resistance $R_L = 200\text{k}\Omega \pm 5\%$.

Propagation delay times shall be measured referenced to the 50% input and output voltages.

Transition time shall be measured referenced to the 10% and 90% output voltage.

2.4 PARAMETER DRIFT VALUES

Unless otherwise specified, the measurements shall be performed at $T_{amb} = +22 \pm 3^{\circ}C$.

The test methods and test conditions shall be as per the corresponding test defined in Para. 2.3.1, Room Temperature Electrical Measurements.

The drift values (Δ) shall not be exceeded for each characteristic specified. The corresponding absolute limit values for each characteristic shall not be exceeded.

Characteristics	Symbols	Limits			Units
		Drift Value Δ	Absolute		
			Min	Max	
Quiescent Current	I_{DD}	± 0.15	-	1	μA
Low Level Output Current 1	I_{OL1}	$\pm 15\% (2)$	510	-	μA
High Level Output Current 1	I_{OH1}	$\pm 15\% (2)$	-510	-	μA
Threshold Voltage N-Channel	V_{THN}	± 0.3	-0.7	-3	V
Threshold Voltage P-Channel	V_{THP}	± 0.3	0.7	3	V

NOTES:

1. Unless otherwise specified all inputs and outputs shall be tested for each characteristic.
2. Percentage of limit value if voltage is the measuring parameter.

2.5 INTERMEDIATE AND END-POINT ELECTRICAL MEASUREMENTS

Unless otherwise specified, the measurements shall be performed at $T_{amb} = +22 \pm 3^{\circ}C$.

The test methods and test conditions shall be as per the corresponding test defined in Para. 2.3.1, Room Temperature Electrical Measurements.

The drift values (Δ) shall not be exceeded for each characteristic where specified. The corresponding absolute limit values for each characteristic shall not be exceeded.

Characteristics	Symbols	Limits			Units
		Drift Value Δ	Absolute		
			Min	Max	
Functional Test 1	-	-	-	-	-
Quiescent Current	I_{DD}	± 0.15	-	1	μA
Low Level Input Current	I_{IL}	-	-	-50	nA
High Level Input Current	I_{IH}	-	-	50	nA
Low Level Output Voltage 1	V_{OL1}	-	-	50	mV
Low Level Output Voltage 2 (Noise Immunity)	V_{OL2}	-	-	500	mV
High Level Output Voltage 1	V_{OH1}	-	14.95	-	V

Characteristics	Symbols	Limits			Units
		Drift Value Δ	Absolute		
			Min	Max	
High Level Output Voltage 2 (Noise Immunity)	V_{OH2}	-	4.5	-	V
Low Level Output Current 1	I_{OL1}	$\pm 15\%$ (3)	510	-	μA
Low Level Output Current 2	I_{OL2}	$\pm 15\%$ (3)	3.4	-	mA
High Level Output Current 1	I_{OH1}	$\pm 15\%$ (3)	-510	-	μA
High Level Output Current 2	I_{OH2}	$\pm 15\%$ (3)	-3.4	-	mA
Threshold Voltage N-Channel	V_{THN}	± 0.3	-0.7	-3	V
Threshold Voltage P-Channel	V_{THP}	± 0.3	0.7	3	V

NOTES:

1. Unless otherwise specified all inputs and outputs shall be tested for each characteristic.
2. The drift values (Δ) are applicable to the Operating Life test only.
3. Percentage of limit value if voltage is the measuring parameter.

2.6 HIGH TEMPERATURE REVERSE BIAS BURN-IN CONDITIONS

2.6.1 N-Channel HTRB

Characteristics	Symbols	Test Conditions	Units
Ambient Temperature	T_{amb}	+125 (+0 -5)	$^{\circ}C$
Outputs Q0, Q1, Q2, EO, GS	V_{OUT}	Open	V
Inputs D4, D5, D6, D7	V_{IN}	V_{SS}	V
Inputs E1, D0, D1, D2, D3	V_{IN}	V_{DD}	V
Positive Supply Voltage	V_{DD}	15 (+0 -0.5)	V
Negative Supply Voltage	V_{SS}	0	V
Duration	t	72	Hours

NOTES

1. Input Protection Resistor = 2k Ω min to 47k Ω max.

2.6.2 P-Channel HTRB

Characteristics	Symbols	Test Conditions	Units
Ambient Temperature	T _{amb}	+125 (+0 -5)	°C
Outputs Q0, Q1, Q2, EO, GS	V _{OUT}	Open	V
Inputs D4, D5, D6, D7	V _{IN}	V _{DD}	V
Inputs EI, D0, D1, D2, D3	V _{IN}	V _{SS}	V
Positive Supply Voltage	V _{DD}	15 (+0 -0.5)	V
Negative Supply Voltage	V _{SS}	0	V
Duration	t	72	Hours

NOTES:

1. Input Protection Resistor = 2kΩ min to 47kΩ max.

2.7 POWER BURN-IN CONDITIONS

Characteristics	Symbols	Test Conditions	Units
Ambient Temperature	T _{amb}	+125 (+0 -5)	°C
Outputs Q0, Q1, Q2, EO, GS	V _{OUT}	V _{DD} /2	V
Inputs Dn	V _{IN}	V _{GEN1}	V
Input EI	V _{IN}	V _{GEN2}	V
Pulse Voltage	V _{GEN}	0V to V _{DD}	V
Pulse Frequency Square Wave	f _{GEN1} f _{GEN2}	50k 25k 50% Duty Cycle	Hz
Positive Supply Voltage	V _{DD}	15 (+0 -0.5)	V
Negative Supply Voltage	V _{SS}	0	V

NOTES:

1. Input Protection Resistor = Output Load = 2kΩ min to 47kΩ max.

2.8 OPERATING LIFE CONDITIONS

The conditions shall be as specified in Para. 2.7, Power Burn-in Conditions.

APPENDIX 'A'
AGREED DEVIATIONS FOR STMICROELECTRONICS (F)

ITEMS AFFECTED	DESCRIPTION OF DEVIATIONS
Para. 2.1.1 Deviations from the Generic Specification: Deviations from Screening Tests - Chart F3	<p>External Visual Inspection: The criteria applicable to chip-outs are those described in MIL-STD-883, Test Method 2009, Paras 3.3.6(b) and 3.3.7(a).</p> <p>High Temperature Reverse Bias Burn-in: The temperature limits of MIL-STD-883, Para. 4.5.8(c) may be used.</p> <p>Power Burn-in test is performed using STMicroelectronics Specification Ref: 0019255.</p> <p>Solderability is not applicable unless specifically stipulated in the Purchase Order.</p>
Para. 2.1.1 Deviations from the Generic Specification: Deviations from Qualification and Periodic Tests - Chart F4	<p>External Visual Inspection: The criteria applicable to chip-outs are those described in MIL-STD-883, Test Method 2009, Paras 3.3.6(b) and 3.3.7(a).</p> <p>Operating Life: The temperature limits of MIL-STD-883, Para. 4.5.8(c) may be used.</p>
Para. 2.3.1 Room Temperature Electrical Measurements	<p>All AC characteristics (Capacitance and Timings) may be considered guaranteed but not tested if successful pilot lot testing has been performed on the wafer lot which includes AC characteristic measurements per the Detail Specification.</p> <p>A summary of the pilot lot testing shall be provided if required by the Purchase Order.</p>
Para. 2.3.2 High and Low Temperatures Electrical Measurements	<p>High and Low Temperatures Electrical Measurements may be considered guaranteed but not tested if successful pilot lot testing has been performed on the wafer lot which includes High and Low Temperatures Electrical Measurements per the Detail Specification.</p> <p>A summary of the pilot lot testing shall be provided if required by the Purchase Order.</p>