



**INTEGRATED CIRCUITS, SILICON MONOLITHIC, CMOS
DUAL 2-LINE TO 4-LINE DECODER/DEMULTIPLEXER
WITH FULLY BUFFERED OUTPUTS**

BASED ON TYPE 4555B

ESCC Detail Specification No. 9408/011

Issue 6	August 2020
---------	-------------



LEGAL DISCLAIMER AND COPYRIGHT

European Space Agency, Copyright © 2020. All rights reserved.

The European Space Agency disclaims any liability or responsibility, to any person or entity, with respect to any loss or damage caused, or alleged to be caused, directly or indirectly by the use and application of this ESCC publication.

This publication, without the prior permission of the European Space Agency and provided that it is not used for a commercial purpose, may be:

- copied in whole, in any medium, without alteration or modification.
- copied in part, in any medium, provided that the ESCC document identification, comprising the ESCC symbol, document number and document issue, is removed.

DOCUMENTATION CHANGE NOTICE

(Refer to <https://escies.org> for ESCC DCR content)

DCR No.	CHANGE DESCRIPTION
1200, 1258	Specification upissued to incorporate changes per DCR.

TABLE OF CONTENTS

1	GENERAL	5
1.1	SCOPE	5
1.2	APPLICABLE DOCUMENTS	5
1.3	TERMS, DEFINITIONS, ABBREVIATIONS, SYMBOLS AND UNITS	5
1.4	THE ESCC COMPONENT NUMBER AND COMPONENT TYPE VARIANTS	5
1.4.1	The ESCC Component Number	5
1.4.2	Component Type Variants	5
1.5	MAXIMUM RATINGS	6
1.6	HANDLING PRECAUTIONS	6
1.7	PHYSICAL DIMENSIONS AND TERMINAL IDENTIFICATION	7
1.7.1	Flat Package (FP) - 16 Pin (Variants 01, 02)	7
1.7.2	Dual-in-line Package (DIP) - 16 Pin (Variants 08, 09)	8
1.7.3	Notes to Physical Dimensions and Terminal Identification	9
1.8	FUNCTIONAL DIAGRAM	9
1.9	PIN ASSIGNMENT	10
1.10	TRUTH TABLE	10
1.11	INPUT PROTECTION NETWORK	10
2	REQUIREMENTS	11
2.1	GENERAL	11
2.1.1	Deviations from the Generic Specification	11
2.2	MARKING	11
2.3	ELECTRICAL MEASUREMENTS AT ROOM, HIGH AND LOW TEMPERATURES	11
2.3.1	Room Temperature Electrical Measurements	11
2.3.2	High and Low Temperatures Electrical Measurements	14
2.3.3	Notes to Electrical Measurement Tables	15
2.4	PARAMETER DRIFT VALUES	16
2.5	INTERMEDIATE AND END-POINT ELECTRICAL MEASUREMENTS	17
2.6	HIGH TEMPERATURE REVERSE BIAS BURN-IN CONDITIONS	18
2.6.1	N-Channel HTRB	18
2.6.2	P-Channel HTRB	18
2.7	POWER BURN-IN CONDITIONS	19
2.8	OPERATING LIFE CONDITIONS	19
	APPENDIX 'A'	20

1 GENERAL

1.1 SCOPE

This specification details the ratings, physical and electrical characteristics and test and inspection data for the component type variants and/or the range of components specified below. It supplements the requirements of, and shall be read in conjunction with, the ESCC Generic Specification listed under Applicable Documents.

1.2 APPLICABLE DOCUMENTS

The following documents form part of this specification and shall be read in conjunction with it:

- (a) ESCC Generic Specification No. [9000](#)
- (b) [MIL-STD-883](#), Test Methods and Procedures for Microelectronics

1.3 TERMS, DEFINITIONS, ABBREVIATIONS, SYMBOLS AND UNITS

For the purpose of this specification, the terms, definitions, abbreviations, symbols and units specified in ESCC Basic Specification No. [21300](#) shall apply.

1.4 THE ESCC COMPONENT NUMBER AND COMPONENT TYPE VARIANTS

1.4.1 The ESCC Component Number

The ESCC Component Number shall be constituted as follows:

Example: 940801101

- Detail Specification Reference: 9408011
- Component Type Variant Number: 01 (as required)

1.4.2 Component Type Variants

The component type variants applicable to this specification are as follows:

Variant Number	Based on Type	Case	Terminal Material and Finish	Weight max g
01	4555B	FP	G2	0.7
02	4555B	FP	G4	0.7
08	4555B	DIP	G2	2.2
09	4555B	DIP	G4	2.2

The terminal material and finish shall be in accordance with the requirements of ESCC Basic Specification No. [23500](#).

1.5 MAXIMUM RATINGS

The maximum ratings shall not be exceeded at any time during use or storage.

Maximum ratings shall only be exceeded during testing to the extent specified in this specification and when stipulated in Test Methods and Procedures of the ESCC Generic Specification.

Characteristics	Symbols	Maximum Ratings	Units	Remarks
Supply Voltage	V_{DD}	-0.5 to 18	V	Note 1
Input Voltage	V_{IN}	-0.5 to $V_{DD}+0.5$	V	Note 2 Power on
Input Current	I_{IN}	± 10	mA	-
Device Power Dissipation (Continuous)	P_D	200	mW	-
Power Dissipation per Output	P_{DSO}	100	mW	Note 3
Operating Temperature Range	T_{op}	-55 to +125	°C	T_{amb}
Storage Temperature Range	T_{stg}	-65 to +150	°C	-
Soldering Temperature	T_{sol}	+265	°C	Note 4

NOTES:

1. Device is functional for $3V \leq V_{DD} \leq 15V$.
2. $V_{DD}+0.5V$ should not exceed +18V.
3. The maximum power dissipation of any single output.
4. Duration 10 seconds maximum at a distance of not less than 1.5mm from the device body and the same terminal shall not be resoldered until 3 minutes have elapsed.

1.6 HANDLING PRECAUTIONS

These devices are susceptible to damage by electrostatic discharge. Therefore, suitable precautions shall be employed for protection during all phases of manufacture, testing, packaging, shipment and any handling.

These components are categorised as Class 1 per ESCC Basic Specification No. [23800](#) with a minimum Critical Path Failure Voltage of 400 Volts.

1.7 PHYSICAL DIMENSIONS AND TERMINAL IDENTIFICATION

Consolidated Notes are given in Para. 1.7.3.

1.7.1 Flat Package (FP) - 16 Pin (Variants 01, 02)

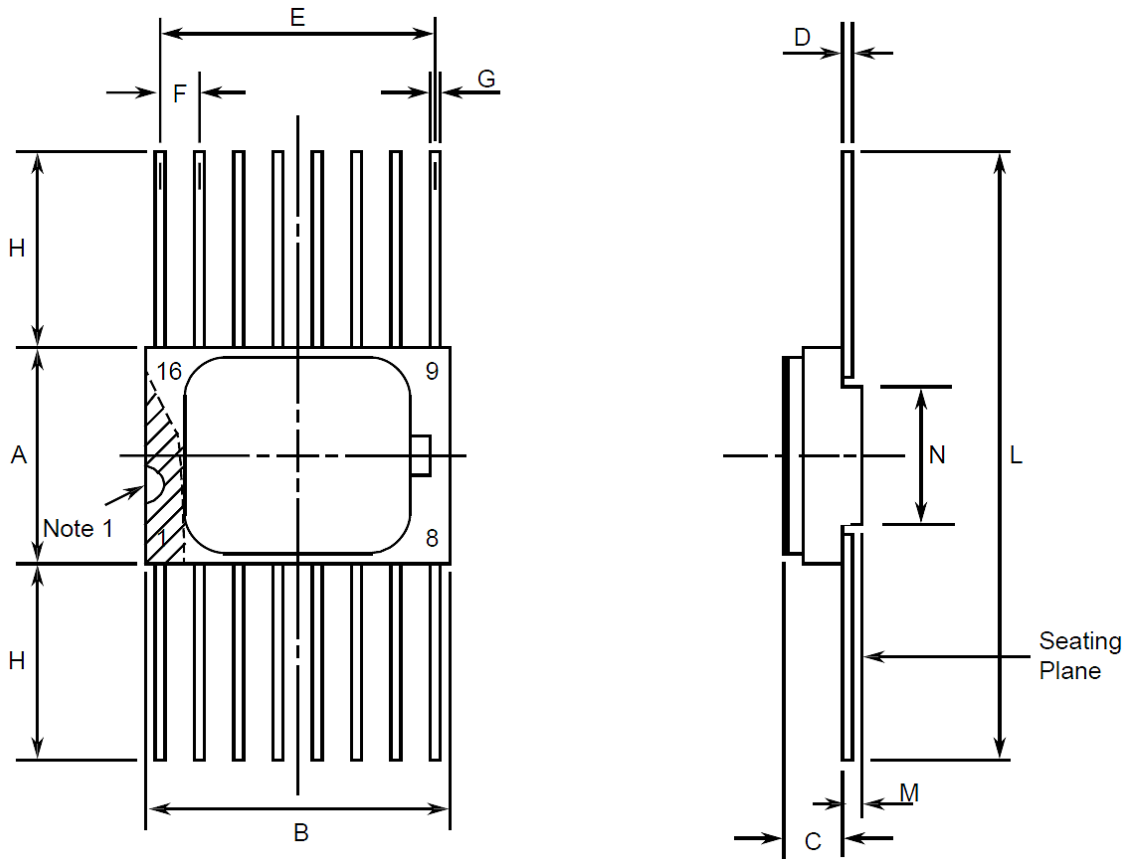

Symbols	Dimensions mm		Notes
	Min	Max	
A	6.75	7.06	
B	9.76	10.14	
C	1.49	1.95	
D	0.1	0.15	5
E	8.76	9.01	
F	1.27 BSC		3, 6
G	0.38	0.48	5
H	6	-	5
L	18.75	22	
M	0.33	0.43	
N	4.32 TYPICAL		

1.7.2 Dual-in-line Package (DIP) - 16 Pin (Variants 08, 09)

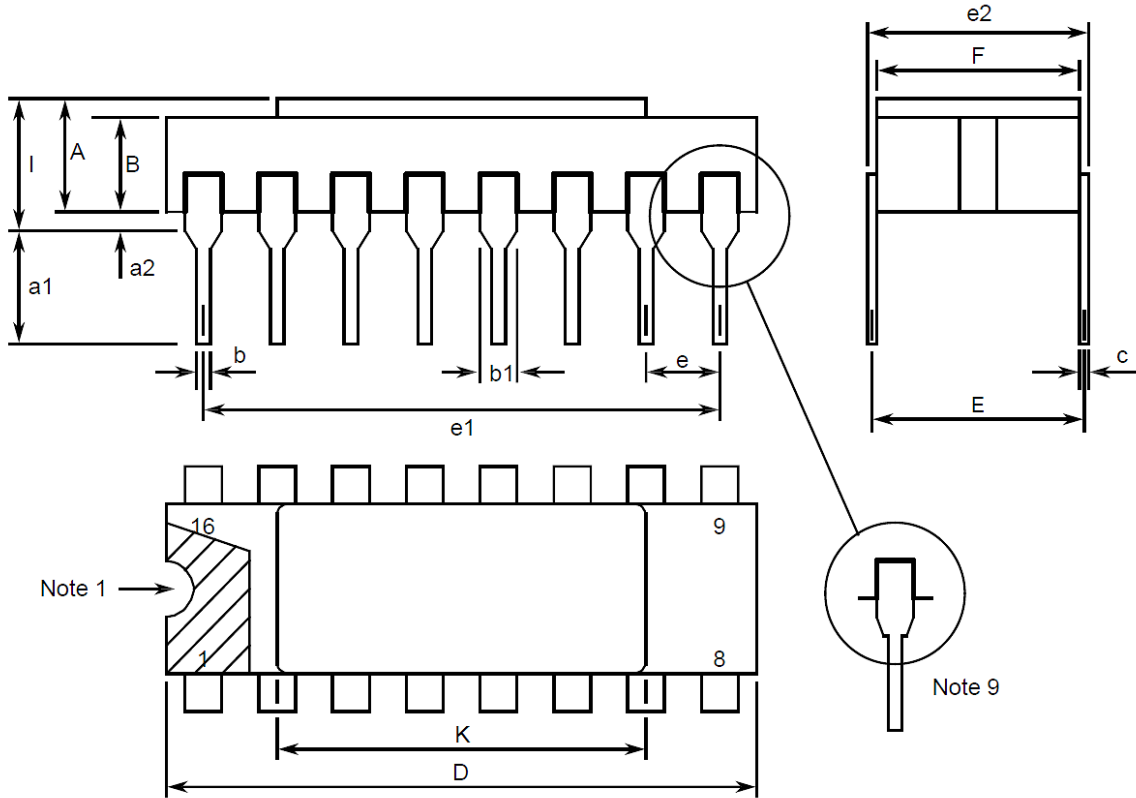

Symbols	Dimensions mm		Notes
	Min	Max	
A	2.1	2.71	
a1	3	3.7	
a2	0.63	1.14	2
B	1.82	2.39	
b	0.4	0.5	5
b1	1.14	1.5	5
c	0.2	0.3	5
D	20.06	20.58	
E	7.36	7.87	
e	2.54 BSC		4, 6
e1	17.65	17.9	
e2	7.62	8.12	
F	7.29	7.7	
I	-	3.83	

Symbols	Dimensions mm		Notes
	Min	Max	
K	10.9	12.1	

1.7.3 Notes to Physical Dimensions and Terminal Identification

1. Index area; a notch or a dot shall be located adjacent to Pin 1 and shall be within the shaded area shown. For chip carrier packages, the index shall be as shown.
2. The dimension shall be measured from the seating plane to the base plane.
3. The true position pin spacing is 1.27mm between centrelines. Each pin centreline shall be located within $\pm 0.13\text{mm}$ of its true longitudinal position relative to Pin 1 and the highest pin number.
4. The true position pin spacing is 2.54mm between centrelines. Each pin centreline shall be located within $\pm 0.25\text{mm}$ of its true longitudinal position relative to Pin 1 and the highest pin number.
5. All terminals.
6. 14 spaces.
9. For all pins, either pin shape may be supplied.

1.8 FUNCTIONAL DIAGRAM

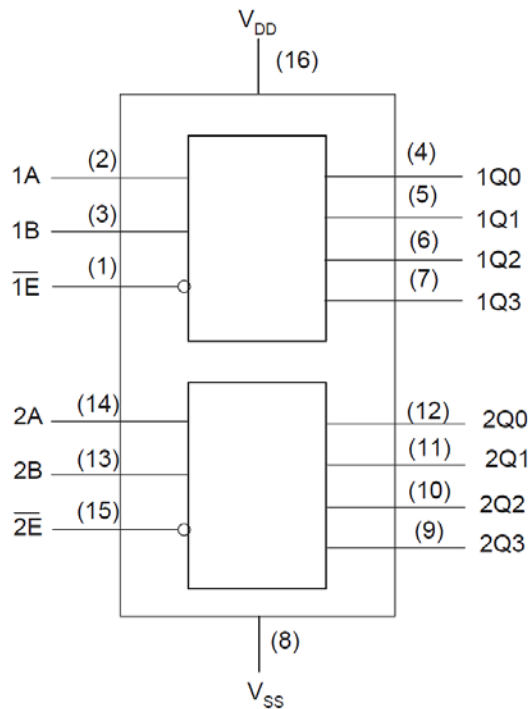

NOTES:

1. The package lid for all packages is not connected to any terminal.

1.9 PIN ASSIGNMENT

Pin	Function	Pin	Function
1	$\overline{1E}$ Input (Enable)	1	$\overline{1E}$ Input (Enable)
2	1A Input (Select)	2	1A Input (Select)
3	1B Input (Select)	11	2Q1 Output
4	1Q0 Output	12	2Q0 Output
5	1Q1 Output	13	2B Input (Select)
6	1Q2 Output	14	2A Input (Select)
7	1Q3 Output	15	$\overline{2E}$ Input (Enable)
8	V_{SS}	16	V_{DD}

1.10 TRUTH TABLE

1. Logic Level Definitions: L = Low Level, H = High Level, X = Irrelevant.

EACH DECODER

INPUTS			OUTPUTS			
ENABLE \overline{E}	SELECT		Q3	Q2	Q1	Q0
	B	A				
L	L	L	L	L	L	H
L	L	H	L	L	H	L
L	H	L	L	H	L	L
L	H	H	H	L	L	L
H	X	X	L	L	L	L

1.11 INPUT PROTECTION NETWORK

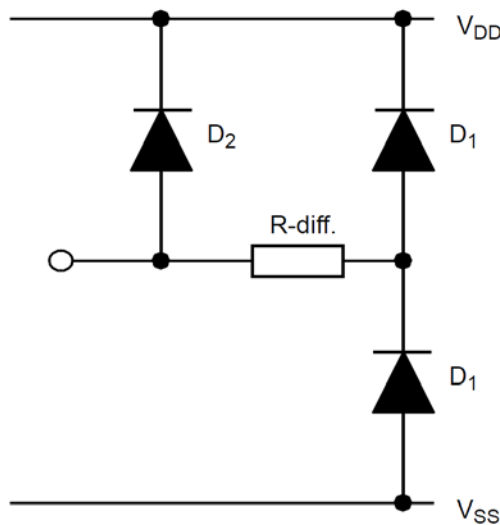

2 REQUIREMENTS

2.1 GENERAL

The complete requirements for procurement of the components specified herein are as stated in this specification and the ESCC Generic Specification. Permitted deviations from the Generic Specification, applicable to this specification only, are listed below.

Permitted deviations from the Generic Specification and this Detail Specification, formally agreed with specific Manufacturers on the basis that the alternative requirements are equivalent to the ESCC requirement and do not affect the component's reliability, are listed in the appendices attached to this specification.

2.1.1 Deviations from the Generic Specification

None.

2.2 MARKING

The marking shall be in accordance with the requirements of ESCC Basic Specification No. 21700 and as follows.

The information to be marked on the component shall be:

- (a) Terminal identification (see Para. 1.7).
- (b) The ESCC qualified components symbol (for ESCC qualified components only).
- (c) The ESCC Component Number (see Para. 1.4.1).
- (d) Traceability information.

2.3 ELECTRICAL MEASUREMENTS AT ROOM, HIGH AND LOW TEMPERATURES

Electrical measurements shall be performed at room, high and low temperatures. Consolidated Notes are given in Para. 2.3.3.

2.3.1 Room Temperature Electrical Measurements

The measurements shall be performed at $T_{amb} = +22 \pm 3^{\circ}C$.

Characteristics	Symbols	MIL-STD-883 Test Method	Test Conditions Note 1	Limits		Units
				Min	Max	
Functional Test 1	-	3014	Verify Truth Table without Load $V_{IL} = 0V, V_{IH} = 3V$ $V_{DD} = 3V, V_{SS} = 0V$ Note 2	-	-	-
Functional Test 2	-	3014	Verify Truth Table without Load $V_{IL} = 0V, V_{IH} = 15V$ $V_{DD} = 15V, V_{SS} = 0V$ Note 2	-	-	-
Quiescent Current	I_{DD}	3005	$V_{IL} = 0V, V_{IH} = 15V$ $V_{DD} = 15V, V_{SS} = 0V$ Note 3	-	1	μA

Characteristics	Symbols	MIL-STD-883 Test Method	Test Conditions Note 1	Limits		Units
				Min	Max	
Low Level Input Current	I _{IL}	3009	V _{IN} (Under Test) = 0V All other inputs = 15V V _{DD} = 15V, V _{SS} = 0V	-	-50	nA
High Level Input Current	I _{IH}	3010	V _{IN} (Under Test) = 15V All other inputs = 0V V _{DD} = 15V, V _{SS} = 0V	-	50	nA
Low Level Output Voltage 1	V _{OL1}	3007	V _{IL} = 0V, V _{IH} = 15V, I _{OL} = 0A V _{DD} = 15V, V _{SS} = 0V	-	50	mV
Low Level Output Voltage 2 (Noise Immunity)	V _{OL2}	3007	V _{IL} = 1.5V, V _{IH} = 3.5V, I _{OL} = 0A V _{DD} = 5V, V _{SS} = 0V	-	500	mV
Low Level Output Voltage 3 (Noise Immunity)	V _{OL3}	3007	V _{IL} = 4V, V _{IH} = 11V, I _{OL} = 0A V _{DD} = 15V, V _{SS} = 0V	-	1.5	V
High Level Output Voltage 1	V _{OH1}	3006	V _{IL} = 0V, V _{IH} = 15V, I _{OH} = 0A V _{DD} = 15V, V _{SS} = 0V	14.95	-	V
High Level Output Voltage 2 (Noise Immunity)	V _{OH2}	3006	V _{IL} = 1.5V, V _{IH} = 3.5V, I _{OH} = 0A V _{DD} = 5V, V _{SS} = 0V	4.5	-	V
High Level Output Voltage 3 (Noise Immunity)	V _{OH3}	3006	V _{IL} = 4V, V _{IH} = 11V, I _{OH} = 0A V _{DD} = 15V, V _{SS} = 0V	13.5	-	V
Low Level Output Current 1	I _{OL1}	-	V _{IL} = 0V, V _{IH} = 5V, V _{OL} = 0.4V V _{DD} = 5V, V _{SS} = 0V Note 4	510	-	μA
Low Level Output Current 2	I _{OL2}	-	V _{IL} = 0V, V _{IH} = 15V, V _{OL} = 1.5V V _{DD} = 15V, V _{SS} = 0V Note 4	3.4	-	mA
High Level Output Current 1	I _{OH1}	-	V _{IL} = 0V, V _{IH} = 5V, V _{OH} = 4.6V V _{DD} = 5V, V _{SS} = 0V Note 4	-510	-	μA
High Level Output Current 2	I _{OH2}	-	V _{IL} = 0V, V _{IH} = 15V, V _{OH} = 13.5V V _{DD} = 15V, V _{SS} = 0V Note 4	-3.4	-	mA
Threshold Voltage N-Channel	V _{THN}	-	$\bar{1}E$ Input at Ground All Other Inputs V _{IN} = 5V V _{DD} = 5V, I _{SS} = -10μA	-0.7	-3	V
Threshold Voltage P-Channel	V _{THP}	-	$\bar{1}E$ Input at Ground All Other Inputs V _{IN} = -5V V _{SS} = -5V, I _{DD} = 10μA	0.7	3	V

Characteristics	Symbols	MIL-STD-883 Test Method	Test Conditions Note 1	Limits		Units
				Min	Max	
Input Clamp Voltage 1, to V_{SS}	V_{IC1}	-	I_{IN} (Under Test) = $-100\mu A$ V_{DD} = Open, V_{SS} = 0V All Other Pins Open	-	-2	V
Input Clamp Voltage 2, to V_{DD}	V_{IC2}	-	V_{IN} (Under Test) = 6V R = 30k Ω , V_{SS} = Open All Other Pins Open Note 5	3	-	V
Input Capacitance	C_{IN}	3012	V_{IN} (Not Under Test) = 0V V_{DD} = V_{SS} = 0V f = 100kHz to 1MHz Note 6	-	7.5	pF
Propagation Delay Low to High 1, 1A to 1Q0	t_{PLH1}	3003	V_{IN} (Under Test) = Pulse Generator V_{IN} (Remaining Inputs) = Truth Table V_{IL} = 0V, V_{IH} = 5V, V_{DD} = 5V, V_{SS} = 0V Note 7	-	390	ns
Propagation Delay High to Low 1, 1A to 1Q0	t_{PHL1}	3003	V_{IN} (Under Test) = Pulse Generator V_{IN} (Remaining Inputs) = Truth Table V_{IL} = 0V, V_{IH} = 5V, V_{DD} = 5V, V_{SS} = 0V Note 7	-	390	ns
Propagation Delay Low to High 2, 1E to 1Q0	t_{PLH2}	3003	V_{IN} (Under Test) = Pulse Generator V_{IN} (Remaining Inputs) = Truth Table V_{IL} = 0V, V_{IH} = 5V, V_{DD} = 5V, V_{SS} = 0V Note 7	-	350	ns
Propagation Delay High to Low 2, 1E to 1Q0	t_{PHL2}	3003	V_{IN} (Under Test) = Pulse Generator V_{IN} (Remaining Inputs) = Truth Table V_{IL} = 0V, V_{IH} = 5V, V_{DD} = 5V, V_{SS} = 0V Note 7	-	350	ns
Transition Time Low to High, 1Q0	t_{TLH}	3004	V_{IN} (Under Test) = Pulse Generator V_{IN} (Remaining Inputs) = Truth Table V_{IL} = 0V, V_{IH} = 5V, V_{DD} = 5V, V_{SS} = 0V Note 7	-	150	ns

Characteristics	Symbols	MIL-STD-883 Test Method	Test Conditions Note 1	Limits		Units
				Min	Max	
Transition Time High to Low, 1Q0	t_{THL}	3004	V_{IN} (Under Test) = Pulse Generator V_{IN} (Remaining Inputs) = Truth Table $V_{IL} = 0V$, $V_{IH} = 5V$, $V_{DD} = 5V$, $V_{SS} = 0V$ Note 7	-	150	ns

2.3.2 High and Low Temperatures Electrical Measurements

The measurements shall be performed at $T_{amb} = +125 (+0 -5)^{\circ}C$ and $T_{amb} = -55 (+5 -0)^{\circ}C$.

Characteristics	Symbols	MIL-STD-883 Test Method	Test Conditions Note 1	Limits		Units
				Min	Max	
Functional Test 1	-	3014	Verify Truth Table without Load $V_{IL} = 0V$, $V_{IH} = 3V$ $V_{DD} = 3V$, $V_{SS} = 0V$ Note 2	-	-	-
Functional Test 2	-	3014	Verify Truth Table without Load $V_{IL} = 0V$, $V_{IH} = 15V$ $V_{DD} = 15V$, $V_{SS} = 0V$ Note 2	-	-	-
Quiescent Current	I_{DD}	3005	$V_{IL} = 0V$, $V_{IH} = 15V$ $V_{DD} = 15V$, $V_{SS} = 0V$ Note 3 $T_{amb} = +125^{\circ}C$ $T_{amb} = -55^{\circ}C$	- -	30 1	μA
Low Level Input Current	I_{IL}	3009	V_{IN} (Under Test) = 0V $V_{DD} = 15V$, $V_{SS} = 0V$ $T_{amb} = +125^{\circ}C$ $T_{amb} = -55^{\circ}C$	- -	-100 -50	nA
High Level Input Current	I_{IH}	3010	V_{IN} (Under Test) = 15V $V_{DD} = 15V$, $V_{SS} = 0V$ $T_{amb} = +125^{\circ}C$ $T_{amb} = -55^{\circ}C$	- -	100 50	nA
Low Level Output Voltage 1	V_{OL1}	3007	$V_{IL} = 0V$, $V_{IH} = 15V$, $I_{OL} = 0A$ $V_{DD} = 15V$, $V_{SS} = 0V$	-	50	mV
Low Level Output Voltage 2 (Noise Immunity)	V_{OL2}	3007	$V_{IL} = 1.5V$, $V_{IH} = 3.5V$, $I_{OL} = 0A$ $V_{DD} = 5V$, $V_{SS} = 0V$	-	500	mV
Low Level Output Voltage 3 (Noise Immunity)	V_{OL3}	3007	$V_{IL} = 4V$, $V_{IH} = 11V$, $I_{OL} = 0A$ $V_{DD} = 15V$, $V_{SS} = 0V$	-	1.5	V
High Level Output Voltage 1	V_{OH1}	3006	$V_{IL} = 0V$, $V_{IH} = 15V$, $I_{OH} = 0A$ $V_{DD} = 15V$, $V_{SS} = 0V$	14.95	-	V

Characteristics	Symbols	MIL-STD-883 Test Method	Test Conditions Note 1	Limits		Units
				Min	Max	
High Level Output Voltage 2 (Noise Immunity)	V _{OH2}	3006	V _{IL} = 1.5V, V _{IH} = 3.5V, I _{OH} = 0A V _{DD} = 5V, V _{SS} = 0V	4.5	-	V
High Level Output Voltage 3 (Noise Immunity)	V _{OH3}	3006	V _{IL} = 4V, V _{IH} = 11V, I _{OH} = 0A V _{DD} = 15V, V _{SS} = 0V	13.5	-	V
Low Level Output Current 1	I _{OL1}	-	V _{IL} = 0V, V _{IH} = 5V, V _{OL} = 0.4V V _{DD} = 5V, V _{SS} = 0V Note 4 T _{amb} = +125°C T _{amb} = -55°C	360 640	- -	µA
Low Level Output Current 2	I _{OL2}	-	V _{IL} = 0V, V _{IH} = 15V, V _{OL} = 1.5V V _{DD} = 15V, V _{SS} = 0V Note 4 T _{amb} = +125°C T _{amb} = -55°C	2.4 4.2	- -	mA
High Level Output Current 1	I _{OH1}	-	V _{IL} = 0V, V _{IH} = 5V, V _{OH} = 4.6V V _{DD} = 5V, V _{SS} = 0V Note 4 T _{amb} = +125°C T _{amb} = -55°C	-360 -640	- -	µA
High Level Output Current 2	I _{OH2}	-	V _{IL} = 0V, V _{IH} = 15V, V _{OH} = 13.5V V _{DD} = 15V, V _{SS} = 0V Note 4 T _{amb} = +125°C T _{amb} = -55°C	-2.4 -4.2	- -	mA
Threshold Voltage N-Channel	V _{THN}	-	1E Input at Ground All Other Inputs V _{IN} = 5V V _{DD} = 5V, I _{SS} = -10µA T _{amb} = +125°C T _{amb} = -55°C	-0.3 -0.7	-3.5 -3.5	V
Threshold Voltage P-Channel	V _{THP}	-	1E Input at Ground All Other Inputs V _{IN} = -5V V _{SS} = -5V, I _{DD} = 10µA T _{amb} = +125°C T _{amb} = -55°C	0.3 0.7	3.5 3.5	V

2.3.3 Notes to Electrical Measurement Tables

1. Unless otherwise specified all inputs and outputs shall be tested for each characteristic, inputs not under test shall be V_{IN} = V_{SS} or V_{DD} and outputs not under test shall be open.
2. Functional tests shall be performed to verify Truth Table with V_{OH} ≥ V_{DD}-0.5V, V_{OL} ≤ 0.5V. The maximum time to output comparator strobe = 300µs.

3. Quiescent Current shall be tested using the following input conditions:
 - (a) All inputs $A = B = \bar{E} = V_{IL}$
 - (b) All inputs $A = B = \bar{E} = V_{IH}$
4. Interchange of forcing and measuring parameters is permitted.
5. Input Clamp Voltage 2 to V_{DD} , V_{IC2} , shall be tested on each input as follows:

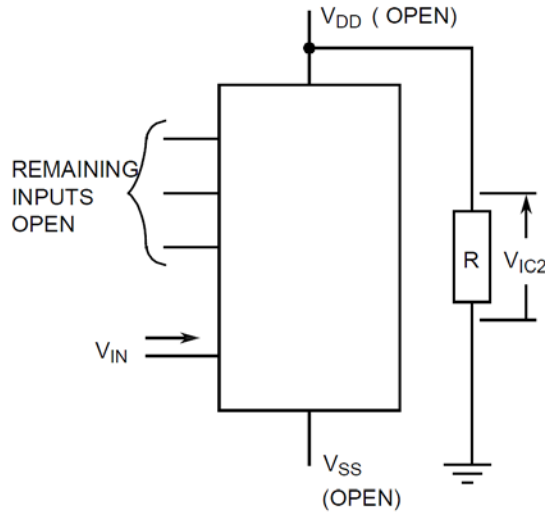

6. Guaranteed but not tested.
7. Read and record measurements shall be performed on a sample of 32 components with 0 failures permitted.

The pulse generator shall have the following characteristics:

$V_{GEN} = 0$ to V_{DD} ; $f_{GEN} = 500\text{kHz}$; t_r and $t_f \leq 20\text{ns}$ (10% to 90%); duty cycle = 50%; $Z_{out} = 50\Omega$. Output load capacitance $C_L = 50\text{pF} \pm 5\%$ including scope probe, wiring and stray capacitance without component in the test fixture. Output load resistance $R_L = 200\text{k}\Omega \pm 5\%$.

Propagation delay shall be measured referenced to the 50% input and output voltages.

Transition time shall be measured referenced to the 10% and 90% output voltage.

2.4 PARAMETER DRIFT VALUES

Unless otherwise specified, the measurements shall be performed at $T_{amb} = +22 \pm 3^\circ\text{C}$.

The test methods and test conditions shall be as per the corresponding test defined in Para. 2.3.1, Room Temperature Electrical Measurements.

The drift values (Δ) shall not be exceeded for each characteristic specified. The corresponding absolute limit values for each characteristic shall not be exceeded.

Characteristics	Symbols	Limits			Units
		Drift Value Δ	Absolute		
			Min	Max	
Quiescent Current	I_{DD}	± 0.15	-	1	μA
Low Level Output Current 1	I_{OL1}	$\pm 15\%$ (2)	510	-	μA
High Level Output Current 1	I_{OH1}	$\pm 15\%$ (2)	-510	-	μA

Characteristics	Symbols	Limits			Units
		Drift Value Δ	Absolute		
			Min	Max	
Threshold Voltage N-Channel	V_{THN}	± 0.3	-0.7	-3	V
Threshold Voltage P-Channel	V_{THP}	± 0.3	0.7	3	V

NOTES:

1. Unless otherwise specified all inputs and outputs shall be tested for each characteristic.
2. Percentage of limit value if voltage is the measuring parameter.

2.5 **INTERMEDIATE AND END-POINT ELECTRICAL MEASUREMENTS**

Unless otherwise specified, the measurements shall be performed at $T_{amb} = +22 \pm 3^{\circ}C$.

The test methods and test conditions shall be as per the corresponding test defined in Para. 2.3.1, Room Temperature Electrical Measurements.

The drift values (Δ) shall not be exceeded for each characteristic where specified. The corresponding absolute limit values for each characteristic shall not be exceeded.

Characteristics	Symbols	Limits			Units
		Drift Value Δ	Absolute		
			Min	Max	
Functional Test 1	-	-	-	-	-
Quiescent Current	I_{DD}	± 0.15	-	1	μA
Low Level Input Current	I_{IL}	-	-	-50	nA
High Level Input Current	I_{IH}	-	-	50	nA
Low Level Output Voltage 1	V_{OL1}	-	-	50	mV
Low Level Output Voltage 2 (Noise Immunity)	V_{OL2}	-	-	500	mV
High Level Output Voltage 1	V_{OH1}	-	14.95	-	V
High Level Output Voltage 2 (Noise Immunity)	V_{OH2}	-	4.5	-	V
Low Level Output Current 1	I_{OL1}	$\pm 15\%$ (3)	510	-	μA
Low Level Output Current 2	I_{OL2}	$\pm 15\%$ (3)	3.4	-	mA
High Level Output Current 1	I_{OH1}	$\pm 15\%$ (3)	-510	-	μA
High Level Output Current 2	I_{OH2}	$\pm 15\%$ (3)	-3.4	-	mA
Threshold Voltage N-Channel	V_{THN}	± 0.3	-0.7	-3	V
Threshold Voltage P-Channel	V_{THP}	± 0.3	0.7	3	V

NOTES:

1. Unless otherwise specified all inputs and outputs shall be tested for each characteristic.
2. The drift values (Δ) are applicable to the Operating Life test only.
3. Percentage of limit value if voltage is the measuring parameter.

2.6 HIGH TEMPERATURE REVERSE BIAS BURN-IN CONDITIONS

2.6.1 N-Channel HTRB

Characteristics	Symbols	Test Conditions	Units
Ambient Temperature	T_{amb}	+125 (+0 -5)	°C
Outputs 1Qn, 2Qn	V_{OUT}	Open	V
Inputs 1A, 1B, $\overline{1E}$, $\overline{2E}$	V_{IN}	V_{SS}	V
Inputs 2A, 2B	V_{IN}	V_{DD}	V
Positive Supply Voltage	V_{DD}	15 (+0 -0.5)	V
Negative Supply Voltage	V_{SS}	0	V
Duration	t	72	Hours

NOTES:

1. Input Protection Resistor = 2k Ω min to 47k Ω max.

2.6.2 P-Channel HTRB

Characteristics	Symbols	Test Conditions	Units
Ambient Temperature	T_{amb}	+125 (+0 -5)	°C
Outputs 1Qn, 2Qn	V_{OUT}	Open	V
Inputs 1A, 1B, $\overline{1E}$, $\overline{2E}$	V_{IN}	V_{DD}	V
Inputs 2A, 2B	V_{IN}	V_{SS}	V
Positive Supply Voltage	V_{DD}	15 (+0 -0.5)	V
Negative Supply Voltage	V_{SS}	0	V
Duration	t	72	Hours

NOTES:

1. Input Protection Resistor = 2k Ω min to 47k Ω max.

2.7 POWER BURN-IN CONDITIONS

Characteristics	Symbols	Test Conditions	Units
Ambient Temperature	T_{amb}	+125 (+0 -5)	°C
Outputs 1Qn, 2Qn	V_{OUT}	$V_{DD}/2$	V
Inputs $\overline{1E}$, $\overline{2E}$	V_{IN}	V_{SS}	V
Inputs 1A, 2A	V_{IN}	V_{GEN1}	V
Inputs 1B, 2B	V_{IN}	V_{GEN2}	V
Pulse Voltage	V_{GEN}	0V to V_{DD}	V
Pulse Frequency Square Wave	f_{GEN1} f_{GEN2}	50k 25k 50% Duty Cycle	Hz
Positive Supply Voltage	V_{DD}	15 (+0 -0.5)	V
Negative Supply Voltage	V_{SS}	0	V

NOTES:

1. Input Protection Resistor = Output Load = 2kΩ min to 47kΩ max.

2.8 OPERATING LIFE CONDITIONS

The conditions shall be as specified in Para. 2.7, Power Burn-in Conditions.

APPENDIX 'A'
AGREED DEVIATIONS FOR STMICROELECTRONICS (F)

ITEMS AFFECTED	DESCRIPTION OF DEVIATIONS
Para. 2.1.1 Deviations from the Generic Specification: Deviations from Screening Tests - Chart F3	<p>External Visual Inspection: The criteria applicable to chip-outs are those described in MIL-STD-883, Test Method 2009, Paras 3.3.6(b) and 3.3.7(a).</p> <p>High Temperature Reverse Bias Burn-in: The temperature limits of MIL-STD-883, Para. 4.5.8(c) may be used.</p> <p>Power Burn-in test is performed using STMicroelectronics Specification Ref: 0019255.</p> <p>Solderability is not applicable unless specifically stipulated in the Purchase Order.</p>
Para. 2.1.1 Deviations from the Generic Specification: Deviations from Qualification and Periodic Tests - Chart F4	<p>External Visual Inspection: The criteria applicable to chip-outs are those described in MIL-STD-883, Test Method 2009, Paras 3.3.6(b) and 3.3.7(a).</p> <p>Operating Life: The temperature limits of MIL-STD-883, Para. 4.5.8(c) may be used.</p>
Para. 2.3.1 Room Temperature Electrical Measurements	<p>All AC characteristics (Capacitance and Timings) may be considered guaranteed but not tested if successful pilot lot testing has been performed on the wafer lot which includes AC characteristic measurements per the Detail Specification.</p> <p>A summary of the pilot lot testing shall be provided if required by the Purchase Order.</p>
Para. 2.3.2 High and Low Temperatures Electrical Measurements	<p>High and Low Temperatures Electrical Measurements may be considered guaranteed but not tested if successful pilot lot testing has been performed on the wafer lot which includes High and Low Temperatures Electrical Measurements per the Detail Specification.</p> <p>A summary of the pilot lot testing shall be provided if required by the Purchase Order.</p>