



**RF CABLE ASSEMBLY, 2.92MM CONNECTORS,
LOW POWER, 50 OHMS, FLEXIBLE CABLE,
DC TO 32 GHZ**

BASED ON TYPE AXOWAVE SL44SQ

ESCC Detail Specification No. 3408/004

Issue 1	January 2021
---------	--------------



LEGAL DISCLAIMER AND COPYRIGHT

European Space Agency, Copyright © 2021. All rights reserved.

The European Space Agency disclaims any liability or responsibility, to any person or entity, with respect to any loss or damage caused, or alleged to be caused, directly or indirectly by the use and application of this ESCC publication.

This publication, without the prior permission of the European Space Agency and provided that it is not used for a commercial purpose, may be:

- copied in whole, in any medium, without alteration or modification.
- copied in part, in any medium, provided that the ESCC document identification, comprising the ESCC symbol, document number and document issue, is removed.

DOCUMENTATION CHANGE NOTICE

(Refer to <https://escies.org> for ESCC DCR content)

DCR No.	CHANGE DESCRIPTION

TABLE OF CONTENTS

1	GENERAL	5
1.1	SCOPE	5
1.2	APPLICABLE DOCUMENTS	5
1.3	TERMS, DEFINITIONS, ABBREVIATIONS, SYMBOLS AND UNITS	5
1.4	THE ESCC COMPONENT NUMBER AND COMPONENT TYPE VARIANTS	5
1.4.1	The ESCC Component Number	5
1.4.1.1	Characteristics Codes	5
1.4.2	Component Type Variants and Range of Components	6
1.5	MAXIMUM RATINGS	7
1.6	PHYSICAL DIMENSIONS	7
1.6.1	Cable Assemblies	7
1.6.1.1	Variant 01	7
1.6.1.2	Variant 02	8
1.6.1.3	Variant 03 (Example : Relative Angle Code 1 ; see Note 1),	8
1.6.1.4	Dimensions applicable to all Variants	9
1.6.2	Connectors	9
1.6.2.1	2.92mm, Male, Straight Plug – used in Variants 01, 02	9
1.6.2.2	2.92mm, Male, Swept (90°) Plug – used in Variants 02, 03	9
1.6.3	Connector Interface Dimensions and Connector Interface Gauge Dimensions	10
1.7	ADD-ON COMPONENTS	10
1.7.1	Connectors	10
1.7.2	Cable	10
1.8	MATERIALS AND FINISHES	10
1.8.1	Connectors	10
1.8.2	Cable	10
2	REQUIREMENTS	11
2.1	GENERAL	11
2.1.1	Deviations from the Generic Specification	11
2.2	MARKING	11
2.3	ENVIRONMENTAL AND MECHANICAL TESTS	11
2.4	ROOM TEMPERATURE ELECTRICAL MEASUREMENTS	12
2.5	INTERMEDIATE AND END-POINT ELECTRICAL MEASUREMENTS	13
	APPENDIX A	15

1 GENERAL

1.1 SCOPE

This specification details the ratings, physical and electrical characteristics and test and inspection data for the component type variants and/or the range of components specified below. It supplements the requirements of, and shall be read in conjunction with, the ESCC Generic Specification listed under Applicable Documents.

1.2 APPLICABLE DOCUMENTS

The following documents form part of this specification and shall be read in conjunction with it:

- (a) ESCC Generic Specification No. [3408](#).
- (b) [MIL-STD-348](#), Department of Defence Interface Standard: Radio Frequency Connector Interfaces.

1.3 TERMS, DEFINITIONS, ABBREVIATIONS, SYMBOLS AND UNITS

For the purpose of this specification, the terms, definitions, abbreviations, symbols and units specified in ESCC Basic Specification No. [21300](#) shall apply.

1.4 THE ESCC COMPONENT NUMBER AND COMPONENT TYPE VARIANTS

1.4.1 The ESCC Component Number

The ESCC Component Number shall be constituted as follows:

Example: 340800402030000

- Detail Specification Reference: 3408004
- Component Type Variant Number: 02 (as required)
- Characteristic code: Total Length (3000mm): 03000 (as required)
- Characteristic code: Relative Angle (N/A): 0 (as required)

1.4.1.1 *Characteristics Codes*

Characteristics to be codified as part of the ESCC Component Number shall be as follows:

(a) **Total Length of Cable Assembly**

The required total nominal length of the cable assembly, L, is expressed by means of the following codes. The unit quantity shall be millimetre (mm):

Total Nominal Length L (mm) (Note 1)	Code
XXX	00XXX
XXXX	0XXXX
XXXXX	XXXXX

NOTES:

1. See Para. 1.4.2 for the available limits for length L (see Para. 1.6.1), and Para. 1.6.1.4 for the tolerances on length L

(b) Relative Angle

The required relative angle (see Para. 1.6.1.3) is expressed by means of the following codes:

Variant Number	Relative Angle	Code
01, 02	N/A	0
03	0°	1
	+90°	2
	+180°	3
	+270°	4

1.4.2 Component Type Variants and Range of Components

The component type variants and range of components applicable to this specification are as follows:

Variant Number	Connector 1 Type (See Paras. 1.6 & 1.7.1)	Connector 2 Type (See Paras. 1.6 & 1.7.1)	Cable Type (See Para. 1.7.2)	Total Length L (mm) (See Para. 1.6.1)	Weight Max (g)
01	2.92mm, Male, Straight Plug	2.92mm, Male, Straight Plug	Flexible Cable Ø4.4mm	250 to 20000 (Note 1)	Note 2
02	2.92mm, Male, Straight Plug	2.92mm, Male, Swept (90°) Plug	Flexible Cable Ø4.4mm	250 to 20000 (Note 1)	Note 2
03	2.92mm, Male, Swept (90°) Plug	2.92mm, Male, Swept (90°) Plug	Flexible Cable Ø4.4mm	250 to 20000 (Note 1)	Note 2

NOTES:

- Any length in the given range is available.
- The cable assembly total maximum weight may be calculated from the connector weights, the cable weight, the protecting sleeve weights and the marking sleeve weight as follows:

- Each connector:

Connector Type	Weight Max (g)
2.92mm, Male, Straight Plug	6
2.92mm, Male, Swept (90°) Plug	6.3

- Cable weight: 34g/m
- Combined weight of two protecting sleeves plus the Marking sleeve: 1.3g maximum.

1.5 MAXIMUM RATINGS

The maximum ratings shall not be exceeded at any time during use or storage.

Maximum ratings shall only be exceeded during testing to the extent specified in this specification and when stipulated in Test Methods and Procedures of the ESCC Generic Specification.

Characteristics	Symbols	Maximum Ratings	Units	Remarks
Nominal Impedance	Z	50	Ω	
Operating Frequency Range	f_{op}	DC to 32	GHz	
Working Voltage	U_R	750	V_{rms}	AC (50Hz) without breakdown
Minimum Bending Radius	R_{min}	50	mm	
Operating Temperature Range	T_{op}	-55 to +125	$^{\circ}C$	T_{amb}
Storage Temperature Range	T_{stg}	-55 to +125	$^{\circ}C$	
Coupling Nut Torque	T_q	170	N.cm	Coupling Proof Torque Note 1

NOTES:

- Whenever a test is performed on mated pairs of connectors, the pairs shall be torqued at 90 ± 10 N.cm.

1.6 PHYSICAL DIMENSIONS

1.6.1 Cable Assemblies

Dimensions L and $\varnothing N$ for all Variants are given in Para. 1.6.1.4.

1.6.1.1 *Variant 01*

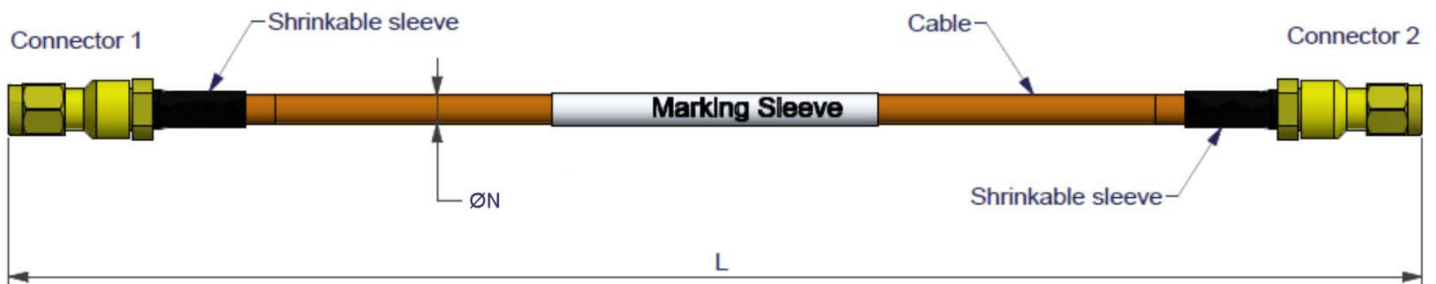

1.6.1.2 Variant 02

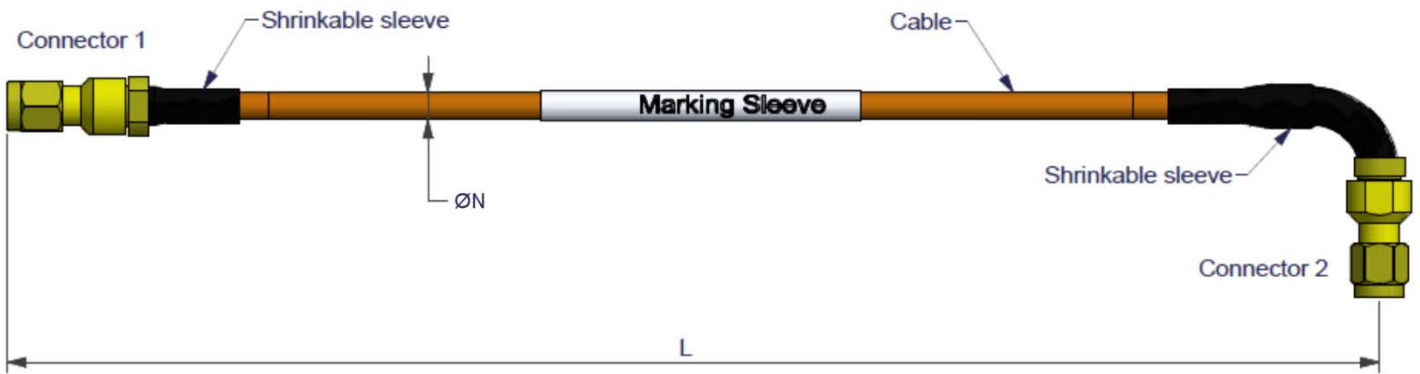

1.6.1.3 Variant 03 (Example : Relative Angle Code 1 ; see Note 1),

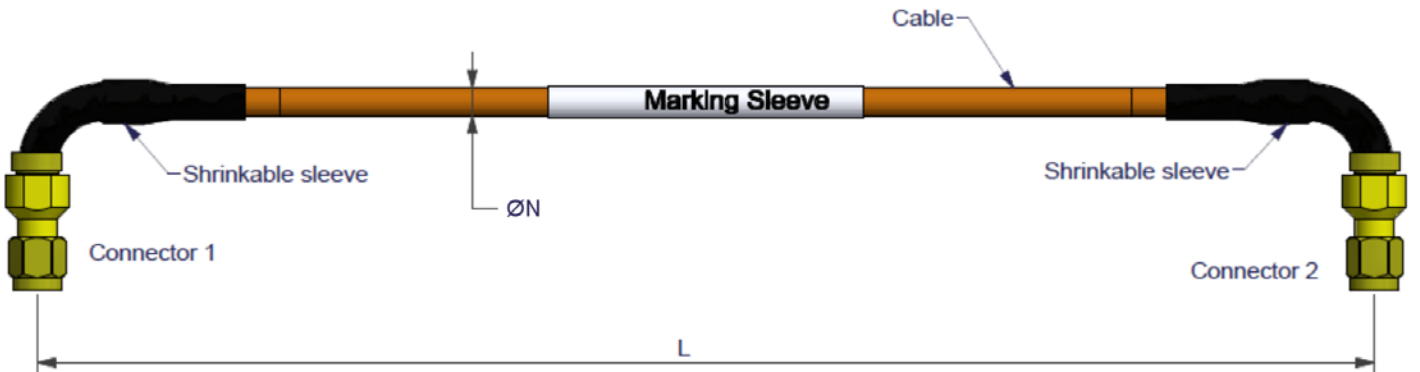

NOTES:

1. Relative Angle: For Variant 03, the positioning of the swept connectors with respect to each other is defined by a codified angle (the relative angle) as shown below:

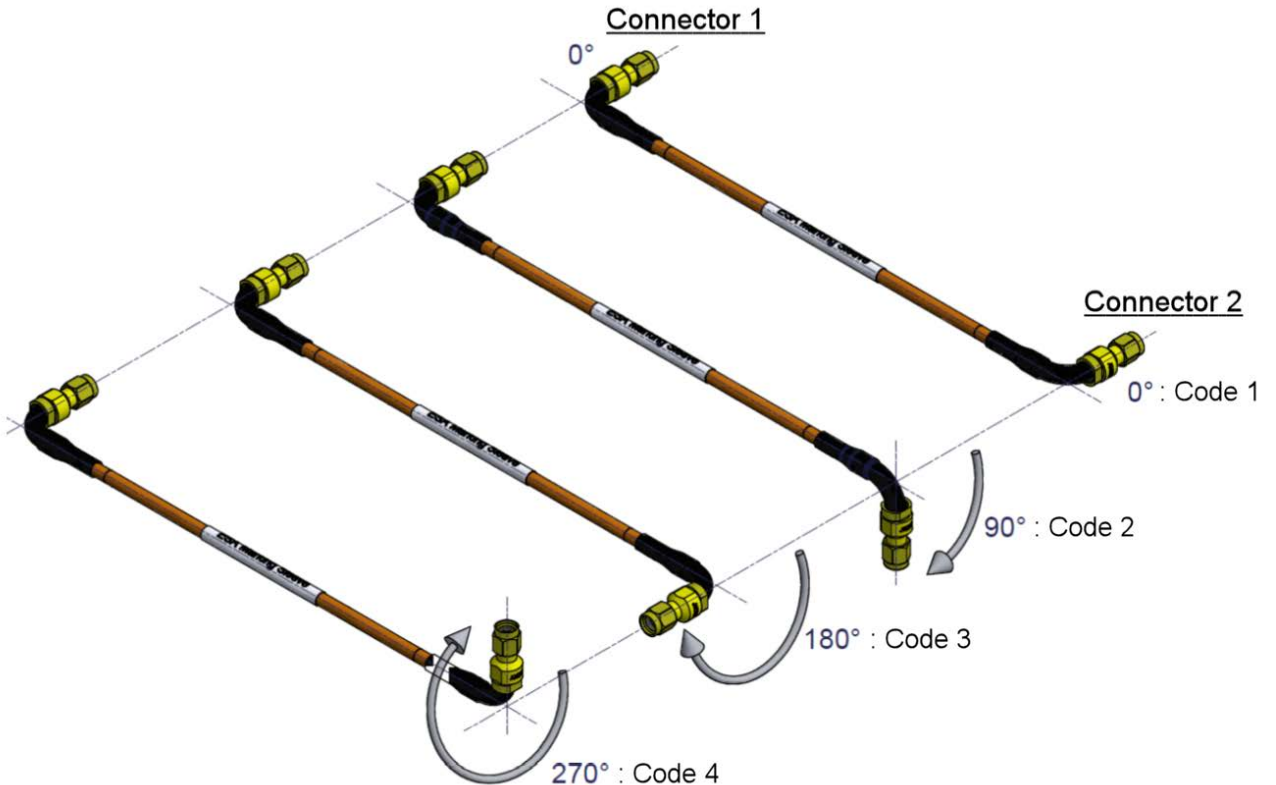

1.6.1.4 Dimensions applicable to all Variants

Symbols	Dimensions mm (Note 1)		Remarks
	Min	Max	
L	L -5	L +5	L = nominal length: 250 to 999mm
	L -10	L +10	L = nominal length: 1000 to 4999mm
	L -30	L -30	L = nominal length: 5000 to 20000mm
ØN	-	4.45	Cable outer diameter

NOTES:

1. For connector dimensions, see Para. 1.6.2.1 or 1.6.2.2 (as applicable) and Para. 1.6.3.

1.6.2 Connectors

1.6.2.1 2.92mm, Male, Straight Plug – used in Variants 01, 02

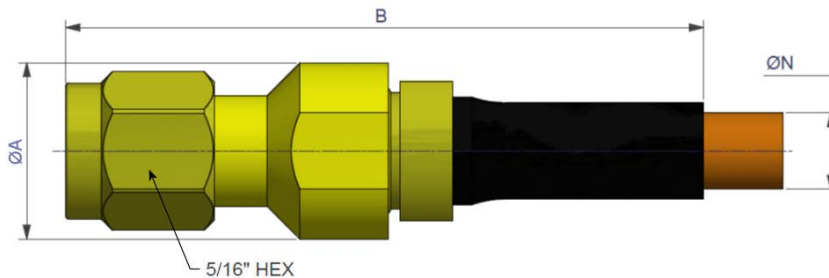

Symbols	Dimensions mm	
	Min	Max
ØA	-	10.05
B	33	39
ØN	-	4.45

NOTES:

1. For connector interface dimensions, see Para. 1.6.3.

1.6.2.2 2.92mm, Male, Swept (90°) Plug – used in Variants 02, 03

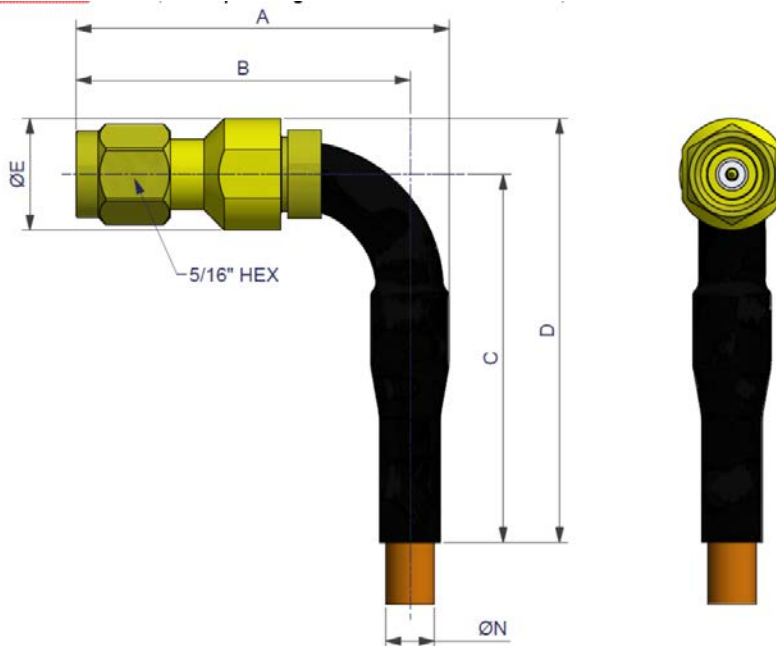

Symbols	Dimensions mm	
	Min	Max
A	-	34.4
B	-	30.7
C	28	38
D	33	43
ØE	-	10.05
ØN	-	4.45

NOTES:

1. For connector interface dimensions, see Para. 1.6.3.

1.6.3 Connector Interface Dimensions and Connector Interface Gauge Dimensions

- (a) 2.92mm Male Connector Interface: compatible with series SMK pin contact interface as specified in [MIL-STD-348](#) Figure 323-1.
- (b) 2.92mm Female Gauge Interface: compatible with series SMK socket contact interface as specified in [MIL-STD-348](#) Figure 323-2.

1.7 ADD-ON COMPONENTS

1.7.1 Connectors

The connectors to be used in the components specified herein shall be RF coaxial connectors, type 2.92mm that meet the requirements of this specification and the ESCC Generic Specification.

1.7.2 Cable

The cable to be used in the components specified herein shall be 4.4mm outer diameter, RF low density PTFE flexible coaxial cable that meets the requirements of this specification and the ESCC Generic Specification.

1.8 MATERIALS AND FINISHES

Materials and finishes shall be as follows.

1.8.1 Connectors

The materials and finishes applicable to the various connectors shall be as follows, as applicable to each connector type:

- (a) Body Shell: Beryllium copper; plated gold 2.54µm minimum over copper 2.54µm minimum.
- (b) Coupling Nut: Beryllium copper; plated gold 2.54µm minimum.
- (c) Rear Nut: Beryllium copper; plated gold 2.54µm minimum.
- (d) Centre Contact: Beryllium copper; plated gold 2.54µm minimum over copper 2.54µm minimum.
- (e) Soldering Sleeve: Brass; plated gold 2.54µm minimum over copper 2.54µm minimum.
- (f) Insulator: PTFE
- (g) Washer: PTFE
- (h) Soldering Sleeve Maintaining Ring (applicable to the swept plug only): Peek 1000
- (i) Protecting Sleeve: Heat-shrinkable Polyolefin tubing; colour: black.

1.8.2 Cable

The materials and finishes applicable to the cable shall be as follows:

- (a) Centre Conductor: Solid SPCCA (silver plated copper clad aluminium), silver plated 2µm minimum.
- (b) Dielectric Core: Low density PTFE.
- (c) Inner Shield: SPC tape (silver plated copper), silver plated 2µm minimum.
- (d) Outer Shield: SPAL braid (silver plated aluminium), silver plated 2.5µm minimum.
- (e) Outer Jacket: Polyimide tapes protected by a Peek braid; colour: ochre.
- (f) Marking Sleeve: Heat-shrinkable Polyolefin tubing; colour: white.

2 REQUIREMENTS

2.1 GENERAL

The complete requirements for procurement of the components specified herein are as stated in this specification and the ESCC Generic Specification. Permitted deviations from the Generic Specification, applicable to this specification only, are listed below.

Permitted deviations from the Generic Specification and this Detail Specification, formally agreed with specific Manufacturers on the basis that the alternative requirements are equivalent to the ESCC requirement and do not affect the component's reliability, are listed in the appendices attached to this specification.

2.1.1 Deviations from the Generic Specification

None.

2.2 MARKING

The marking shall be in accordance with the requirements of ESCC Basic Specification No. [21700](#) and as follows.

The information to be marked on the component shall be:

- (a) The ESCC qualified components symbol (for ESCC qualified components only).
- (b) The ESCC Component Number (see Para. 1.4.1).
- (c) Traceability information.

2.3 ENVIRONMENTAL AND MECHANICAL TESTS

The following requirements apply to tests performed on the connector (and contact) lot, the cable lot and the cable assembly lot, as specified in the ESCC Generic Specification:

- (a) Para. 8.2, Contact Capability: Not applicable (due to the contact type).
- (b) Para. 8.4, Plating Thickness: Plating thicknesses: see Para. 1.8.1.
- (c) Para. 8.5, Magnetism Level: Not applicable.
- (d) Para. 8.7, Insulation Flaws:
 - Applied voltage: 500Vrms
 - Leakage Current: < 5mA
 - Insulation Resistance: > 1GΩ
- (e) Para. 8.11, Adhesion of Inner Conductor: 4N minimum.
- (f) Para. 8.12, Dielectric Strength of Jacket:
 - Test voltage: 1kVac
 - Frequency: 50Hz
- (g) Para. 8.13, Conductor Resistance: 26.2 Ω/km.
- (h) Para. 8.14, Capacitance: 87pF/m.
- (i) Para. 8.15, Characteristic Impedance: 50 ±2Ω.
- (j) Para. 8.17.2.1, Temperature Cycling I (Chart F4A): Not applicable.
- (k) Para. 8.18, Coupling Proof Torque: See Para. 1.5.

- (l) Para. 8.19, Mating and Unmating Forces:
 - Para. 8.19.1, During Screening Tests (Chart F3): Not applicable (due to the connector type).
 - Para. 8.19.2, During Qualification Testing and Lot Validation Testing (Chart F4A): 24N.cm maximum.
- (m) Para. 8.21, Multipaction: Shall not be performed.
- (n) Para. 8.26, Cable Retention Force: 40N.
- (o) Para. 8.27, Radiation: Radiation dosage: 300Mrad.
- (p) Para. 8.32, Corona: Shall not be performed.
- (q) Para. 8.33, RF Power Handling: Shall not be performed.
- (r) Para. 8.34, RF Power Cycling: Shall not be performed.
- (s) Para. 8.36, Crimp Contact Tensile Strength: Not applicable.

2.4 ROOM TEMPERATURE ELECTRICAL MEASUREMENTS

The measurements shall be performed at $T_{amb} = +22 \pm 3^{\circ}\text{C}$.

Characteristics	Symbols	Test Method and Conditions	Limits		Units
			Min	Max	
Dielectric Withstanding Voltage	DWV	ESCC No. 3408 Note 1	750	-	Vrms
Voltage Proof Leakage Current	I _{VPL}	Note 2	-	5	mA
Insulation Resistance	R _i	ESCC No. 3408	1000	-	MΩ
Voltage Standing Wave Ratio	VSWR	ESCC No. 3408 RF Power = 1mW f = DC to 32GHz	-	1.25	-
Insertion Loss	IL	ESCC No. 3408 f = DC to 32GHz	-	Note 3	dB

NOTES:

1. Test voltage shall be applied between inner and outer conductors.
2. Measured during Dielectric Withstanding Voltage.
3. IL maximum limits, where the cable assembly length L is in metres and the test frequency f is in GHz, shall be calculated as follows:
 - Variant 01: $IL \leq 0.05 \times \sqrt{f} + (0.275 \times \sqrt{f} + 0.011 \times f) \times L$
 - Variant 02: $IL \leq 0.05 \times \sqrt{f} + (0.275 \times \sqrt{f} + 0.011 \times f) \times (L + 0.028)$
 - Variant 03: $IL \leq 0.05 \times \sqrt{f} + (0.275 \times \sqrt{f} + 0.011 \times f) \times (L + 0.056)$

2.5 INTERMEDIATE AND END-POINT ELECTRICAL MEASUREMENTS

Unless otherwise specified, the measurements shall be performed at $T_{amb} = +22 \pm 3^{\circ}C$

Unless otherwise specified, test methods and test conditions shall be as per the corresponding test defined in Para. 2.4, Room Temperature Electrical Measurements.

Test Reference per ESCC No. 3408	Characteristics	Symbols	Limits		Units
			Min	Max	
Temperature Cycling II Final Measurements	Voltage Standing Wave Ratio	VSWR	Note 1		
	Insertion Loss	IL	Note 1		
Electrical Measurements at Room, High and Low Temperatures	At room temperature ($T_{amb} = +22 \pm 3^{\circ}C$):				dB
	Dielectric Withstanding Voltage	DWV	Note 1		
	Voltage Proof Leakage Current	I_{VPL}	Note 1		
	Insulation Resistance	I_R	Note 1		
	Voltage Standing Wave Ratio	VSWR	Note 1		
	Insertion Loss	IL	Note 1		
	At high temperature ($T_{amb} = +125 (+0 -5)^{\circ}C$):				
	Dielectric Withstanding Voltage	DWV	Note 1		
	Voltage Proof Leakage Current	I_{VPL}	Note 1		
	Insulation Resistance	I_R	Note 1		
	Voltage Standing Wave Ratio	VSWR	Note 1		
	Insertion Loss	IL	-	Note 2	
	At low temperature ($T_{amb} = -55 (+5 -0)^{\circ}C$):				
	Dielectric Withstanding Voltage	DWV	Note 1		
	Voltage Proof Leakage Current	I_{VPL}	Note 1		
	Insulation Resistance	I_R	Note 1		
	Voltage Standing Wave Ratio	VSWR	Note 1		
	Insertion Loss	IL	-	Note 2	
Shielding Effectiveness	Shielding Effectiveness DC to 18GHz: 18 to 32GHz:	SE	80	-	dB
			65	-	
Cable Retention Force Initial Measurement Final Measurements	Voltage Standing Wave Ratio	VSWR	Note 1		
	Voltage Standing Wave Ratio	VSWR	Note 1		
	Insertion Loss	IL	Note 1		
Radiation Initial Measurements Final Measurements	Voltage Standing Wave Ratio	VSWR	Note 1		
	Insertion Loss	IL	Note 1		
	Dielectric Withstanding Voltage	DWV	Note 1		
	Voltage Proof Leakage Current	I_{VPL}	Note 1		
	Insulation Resistance	I_R	Note 1		
	Voltage Standing Wave Ratio	VSWR	Note 1		
	Insertion Loss	IL	Note 1		

Test Reference per ESCC No. 3408	Characteristics	Symbols	Limits		Units
			Min	Max	
Ageing	Voltage Standing Wave Ratio Insertion Loss	VSWR IL	Note 1 Note 1		
Bending	Voltage Standing Wave Ratio Insertion Loss	VSWR IL	Note 1 Note 1		
Random Vibration	Voltage Standing Wave Ratio Insertion Loss	VSWR IL	Note 1 Note 1		
Sine Vibration	Voltage Standing Wave Ratio Insertion Loss	VSWR IL	Note 1 Note 1		

NOTES:

1. The limits specified in Para. 2.4, Room Temperature Electrical Measurements shall apply.
2. IL maximum limits at high and low temperatures shall be calculated using IL measured at room temperature and the applicable test temperature T in °C as follows:
 - $IL (at T) = 1.05 \times IL (at 22^{\circ}C) \times \sqrt{1 + (T - 22) \times 0.0038}$

APPENDIX A
AGREED DEVIATIONS FOR AXON (F)

Items Affected	Description of Deviations
Para. 1.7, Add-on Components	Para. 1.7.1, Connectors: The following connector types, as specified in Axon PID CNES-PID-19, shall apply: <ul style="list-style-type: none"> • 2.92mm straight plug: P576330A • 2.92mm swept (90°) plug: P576331A Para. 1.7.2, Cable: The following cable type, as specified in Axon PID CNES-PID-19-Axon, shall apply: <ul style="list-style-type: none"> • Flexible Cable Ø4.4mm: type SL44SQ, referenced P849542D, in accordance with Axon technical specification: 11012-TS-A-01.
Para. 2.1.1, Deviations from the Generic Specification: Deviations from Production Control – Chart F2	Para. 8.9, Anthony and Brown Test: This test shall be performed only on the conductor prior to cable manufacturing (it shall not be performed on the finished cable).
Para. 2.1.1, Deviations from the Generic Specification: Deviations from Screening Tests – Chart F3	Para. 8.18, Coupling Proof Torque: This test shall only be performed during Qualification Testing or Periodic Testing.