



Page 1 of 18

TRANSISTORS, LOW POWER, PNP

BASED ON TYPE 2N2907A

ESCC Detail Specification No. 5202/001

Issue 10	October 2020
----------	--------------



Document Custodian: European Space Agency – see <https://escies.org>

LEGAL DISCLAIMER AND COPYRIGHT

European Space Agency, Copyright © 2020. All rights reserved.

The European Space Agency disclaims any liability or responsibility, to any person or entity, with respect to any loss or damage caused, or alleged to be caused, directly or indirectly by the use and application of this ESCC publication.

This publication, without the prior permission of the European Space Agency and provided that it is not used for a commercial purpose, may be:

- copied in whole, in any medium, without alteration or modification.
- copied in part, in any medium, provided that the ESCC document identification, comprising the ESCC symbol, document number and document issue, is removed.

DOCUMENTATION CHANGE NOTICE

(Refer to <https://escies.org> for ESCC DCR content)

DCR No.	CHANGE DESCRIPTION
1365	Specification updated to incorporate changes per DCR.

TABLE OF CONTENTS

1	GENERAL	5
1.1	SCOPE	5
1.2	APPLICABLE DOCUMENTS	5
1.3	TERMS, DEFINITIONS, ABBREVIATIONS, SYMBOLS AND UNITS	5
1.4	THE ESCC COMPONENT NUMBER AND COMPONENT TYPE VARIANTS	5
1.4.1	The ESCC Component Number	5
1.4.2	Component Type Variants	6
1.5	MAXIMUM RATINGS	7
1.6	PHYSICAL DIMENSIONS AND TERMINAL IDENTIFICATION	8
1.6.1	Metal Can Package (TO-18) - 3 lead	8
1.6.2	Chip Carrier Package (CCP) - 3 terminal	9
1.6.3	Chip Carrier Package (CCP) - 4 terminal	10
1.6.4	Die	11
1.7	FUNCTIONAL DIAGRAM	11
1.8	MATERIALS AND FINISHES	12
1.8.1	Materials and Finishes of Packaged Components	12
1.8.2	Materials and Finishes of Die Components	12
2	REQUIREMENTS	12
2.1	GENERAL	12
2.1.1	Deviations from the Generic Specification	12
2.2	MARKING	12
2.3	TERMINAL STRENGTH	12
2.4	ELECTRICAL MEASUREMENTS AT ROOM, HIGH AND LOW TEMPERATURES	13
2.4.1	Room Temperature Electrical Measurements	13
2.4.2	High and Low Temperatures Electrical Measurements	15
2.5	PARAMETER DRIFT VALUES	15
2.6	INTERMEDIATE AND END-POINT ELECTRICAL MEASUREMENTS	15
2.7	HIGH TEMPERATURE REVERSE BIAS BURN-IN CONDITIONS	16
2.8	POWER BURN-IN CONDITIONS	16
2.9	OPERATING LIFE CONDITIONS	16
2.10	TOTAL DOSE RADIATION TESTING	16
2.10.1	Bias Conditions and Total Dose Level for Total Dose Radiation Testing	16
2.10.2	Electrical Measurements for Radiation Testing	17
	APPENDIX 'A'	18

1 GENERAL

1.1 SCOPE

This specification details the ratings, physical and electrical characteristics and test and inspection data for the component type variants and/or the range of components specified below. It supplements the requirements of, and shall be read in conjunction with, the ESCC Generic Specification listed under Applicable Documents.

1.2 APPLICABLE DOCUMENTS

The following documents form part of this specification and shall be read in conjunction with it:

- (a) ESCC Generic Specification No. [5000](#)
- (b) [MIL-STD-750](#), Test Methods and Procedures for Semiconductor Devices

1.3 TERMS, DEFINITIONS, ABBREVIATIONS, SYMBOLS AND UNITS

For the purpose of this specification, the terms, definitions, abbreviations, symbols and units specified in ESCC Basic Specification No. [21300](#) shall apply.

1.4 THE ESCC COMPONENT NUMBER AND COMPONENT TYPE VARIANTS

1.4.1 The ESCC Component Number

The ESCC Component Number shall be constituted as follows:

Example: 520200101R

- Detail Specification Reference: 5202001
- Component Type Variant Number: 01 (as required)
- Total Dose Radiation Level Letter: R (as required)

1.4.2 Component Type Variants

The component type variants applicable to this specification are as follows:

Variant Number	Based on Type	Case	Lead/Terminal Material and/or Finish (Note 1)	Weight max g	Total Dose Radiation Level Letter (Note 2)
01	2N2907A	TO-18	D2	0.4	R [100krad(Si)]
02	2N2907A	TO-18	D3 or D4	0.4	R [100krad(Si)]
04	2N2907A	CCP (3 Terminal)	2	0.06	R [100krad(Si)]
05	2N2907A	CCP (3 Terminal)	4	0.06	R [100krad(Si)]
06	2N2907A	CCP (4 Terminal)	2	0.06	R [100krad(Si)]
07	2N2907A	CCP (4 Terminal)	4	0.06	R [100krad(Si)]
08	2N2907A	Die (Note 3)	N/A	N/A	R [100krad(Si)]
09	2N2907A	Die (Note 4)	N/A	N/A	Note 4

NOTES:

1. The lead/terminal material and/or finish shall be in accordance with the requirements of ESCC Basic Specification No. [23500](#).
2. Total dose radiation level letters are defined in ESCC Basic Specification No. [22900](#). If an alternative radiation test level is specified in the Purchase Order, the letter shall be changed accordingly.
3. Variant 08 is a die with 2.85µm top metallisation, see Para. 1.6.4.
4. Variant 09 is a die with 2µm top metallisation, see Para. 1.6.4, and is not available with Total Dose Radiation Testing.

1.5 MAXIMUM RATINGS

The maximum ratings shall not be exceeded at any time during use or storage.

Maximum ratings shall only be exceeded during testing to the extent specified in this specification and when stipulated in Test Methods and Procedures of the ESCC Generic Specification.

Characteristics	Symbols	Maximum Ratings	Unit	Remarks
Collector-Base Voltage	V_{CBO}	-60	V	Over entire operating temperature range
Collector-Emitter Voltage	V_{CEO}	-60	V	
Emitter-Base Voltage	V_{EBO}	-5	V	
Collector Current For TO-18 For CCP	I_c	-600 -500	mA	Continuous
Power Dissipation For TO-18 and CCP	P_{tot1}	0.4	W	At $T_{amb} \leq +25^{\circ}C$
For TO-18	P_{tot2}	1.8	W	At $T_{case} \leq +25^{\circ}C$
Thermal Resistance, Junction-to-Ambient	$R_{th(j-a)}$	437.5	$^{\circ}C/W$	
Thermal Resistance, Junction-to-Case	$R_{th(j-c)}$	97.2	$^{\circ}C/W$	Note 1
Operating Temperature Range	T_{op}	-65 to +200	$^{\circ}C$	Note 2
Storage Temperature Range	T_{stg}	-65 to +200	$^{\circ}C$	Note 2
Soldering Temperature For TO-18 For CCP	T_{sol}	+260 +245	$^{\circ}C$	Note 3 Note 4

NOTES:

1. Thermal Resistance, Junction-to-Case only applies to TO-18 packaged Variants.
2. For Variants with tin-lead plating or hot solder dip lead finish all testing, and any handling, performed at $T_{amb} > +125^{\circ}C$ shall be carried out in a 100% inert atmosphere.
3. Duration 10 seconds maximum at a distance of not less than 1.5mm from the device body and the same lead shall not be resoldered until 3 minutes have elapsed.
4. Duration 5 seconds maximum and the same terminal shall not be resoldered until 3 minutes have elapsed.

1.6 PHYSICAL DIMENSIONS AND TERMINAL IDENTIFICATION

1.6.1 Metal Can Package (TO-18) - 3 lead

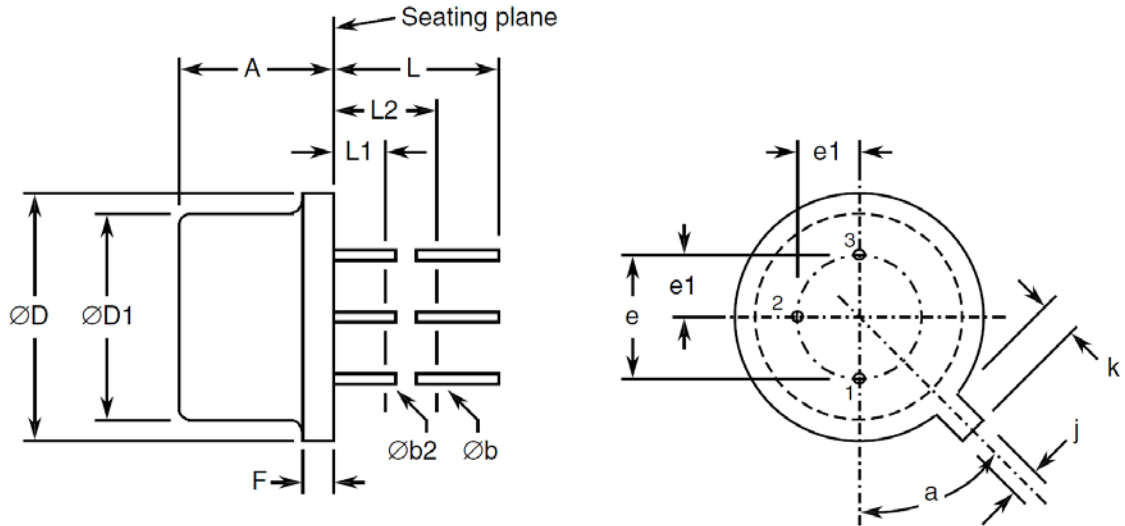

Symbols	Dimensions mm		Notes
	Min	Max	
A	4.32	5.33	
$\varnothing b$	0.406	0.533	2, 3
$\varnothing b2$	0.406	0.483	2, 3
$\varnothing D$	5.31	5.84	
$\varnothing D1$	4.52	4.95	
e	2.54 BSC		4
e1	1.27 BSC		4
F	-	0.762	
j	0.914	1.17	
k	0.711	1.22	5
L	12.7	-	2
L1	-	1.27	3
L2	6.35	-	3
a	45° BSC		1, 4, 6

NOTES:

- Terminal identification is specified by reference to the tab position where lead 1 = emitter, lead 2 = base, lead 3 = collector.
- Applies to all leads.
- $\varnothing b2$ applies between L1 and L2. $\varnothing b$ applies between L2 and 12.7mm from the seating plane. Diameter is uncontrolled within L1 and beyond 12.7mm from the seating plane.

4. Leads having maximum diameter 0.483mm measured in the gauging plane 1.37 (+0.025, -0) mm below the seating plane of the device shall be within 0.178mm of their true position relative to a maximum-width-tab.
5. Measured from the maximum diameter of the actual device.
6. Tab centreline.

1.6.2 Chip Carrier Package (CCP) - 3 terminal

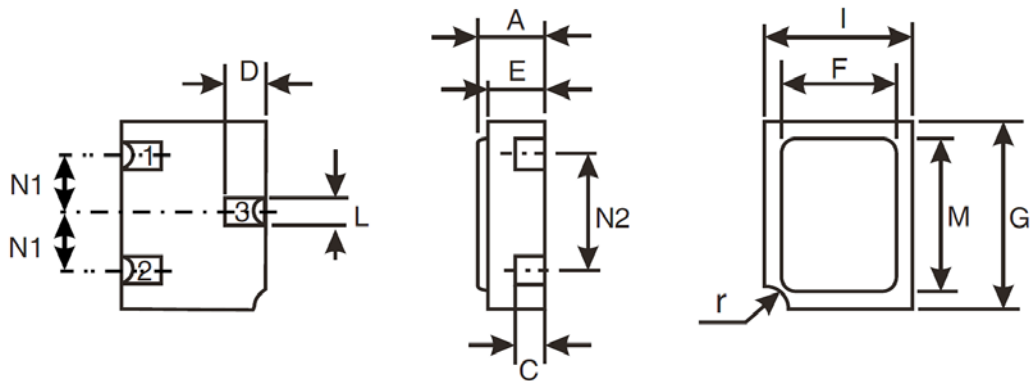

Symbols	Dimensions mm		Notes
	Min	Max	
A	1.15	1.5	
C	0.45	0.56	2
D	0.6	0.91	2
E	0.91	1.12	
F	1.9	2.15	
G	2.9	3.25	
I	2.4	2.85	
L	0.4	0.6	2
M	2.4	2.65	
N1	0.855	1.055	
N2	1.8	2	
r	0.3 TYPICAL		1

NOTES:

1. Terminal identification is specified by reference to the corner notch position where terminal 1 = emitter, terminal 2 = base, terminal 3 = collector.
2. Applies to all terminals.

1.6.3 Chip Carrier Package (CCP) - 4 terminal

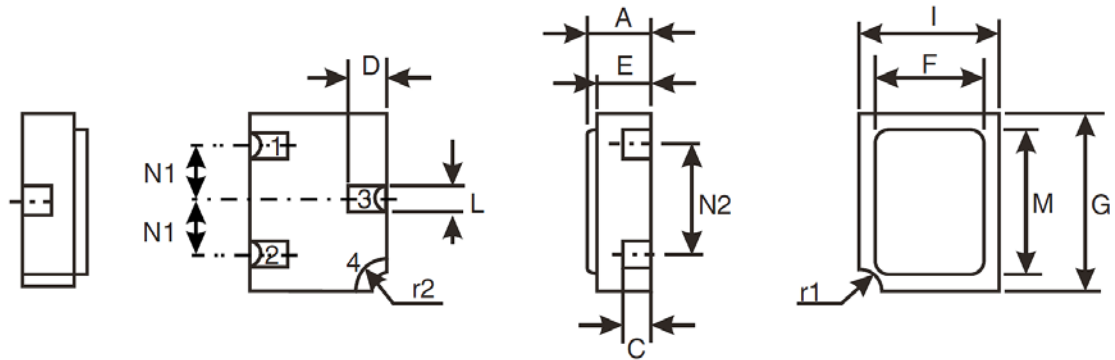

Symbols	Dimensions mm		Notes
	Min	Max	
A	1.15	1.5	
C	0.45	0.56	2
D	0.6	0.91	2
E	0.91	1.12	
F	1.9	2.15	
G	2.9	3.25	
I	2.4	2.85	
L	0.4	0.6	2
M	2.4	2.65	
N1	0.855	1.055	
N2	1.8	2	
r1	0.3 TYPICAL		1
r2	0.56 TYPICAL		1

NOTES:

- Terminal identification is specified by reference to the corner notch position where terminal 1 = emitter, terminal 2 = base, terminal 3 = collector, terminal 4 = shielding connected to the lid.
- Applies to terminals 1, 2, 3.

1.6.4 Die (Variants 08, 09)

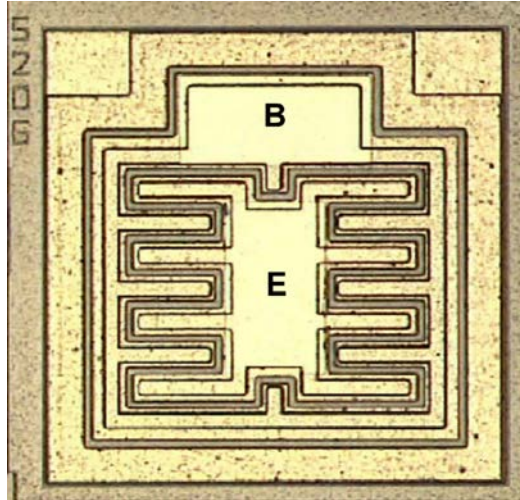

NOTES:

1. Die materials and dimensions:
 - Die substrate: Silicon
 - Die length: 508 μm
 - Die width: 508 μm
 - Die thickness: 230 $\pm 20\mu\text{m}$
 - Top Glassivation: P-Vapox with thickness: 720 $\pm 80\text{nm}$ and Nitride with thickness 540 $\pm 60\text{nm}$
 - Top metallisation:
 - Variant 08: Al/Si (1%) with thickness: 2.85 $\pm 0.15\mu\text{m}$
 - Variant 09: Al/Si (1%) with thickness: 2 $\pm 0.2\mu\text{m}$
 - Backside metallisation: Au with thickness: 1.48 $\pm 0.12\mu\text{m}$
 - Emitter pad dimensions: 154 \times 84 μm
 - Base pad dimensions: 163 \times 80 μm
2. Terminal identification: B = Base, E = Emitter
3. Bias details: backside contact = Collector

1.7 FUNCTIONAL DIAGRAM

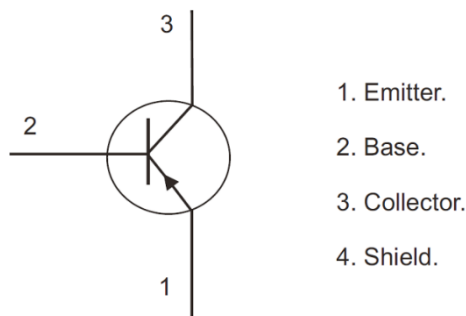

NOTES:

1. For TO-18 (Variants 01, 02), the collector is internally connected to the case.
2. For 3 terminal CCP (Variants 04, 05) the lid is not connected to any terminal.
3. For 4 terminal CCP (Variants 06, 07) the shielding terminal is connected to the lid.
4. For Die Components (Variants 08, 09), the terminal numbering and the Shield are not applicable.

1.8 MATERIALS AND FINISHES

1.8.1 Materials and Finishes of Packaged Components

For Variants 01, 02, 04, 05, 06 and 07, the materials and finishes shall be as follows:

(a) Case

For the metal can package the case shall be hermetically sealed and have a metal body with hard glass seals.

For chip carrier packages, the case shall be hermetically sealed and have a ceramic body with a Kovar lid.

(b) Leads/Terminals

As specified in Para. 1.4.2, Component Type Variants.

1.8.2 Materials and Finishes of Die Components

For Variants 08 and 09, the materials and finishes shall be as specified in Para. 1.6.4.

2 REQUIREMENTS

2.1 GENERAL

The complete requirements for procurement of the components specified herein are as stated in this specification and the ESCC Generic Specification. Permitted deviations from the Generic Specification, applicable to this specification only, are listed below.

Permitted deviations from the Generic Specification and this Detail Specification, formally agreed with specific Manufacturers on the basis that the alternative requirements are equivalent to the ESCC requirement and do not affect the component's reliability, are listed in the appendices attached to this specification.

2.1.1 Deviations from the Generic Specification

None.

2.2 MARKING

The marking shall be in accordance with the requirements of ESCC Basic Specification No. 21700 and as follows.

The information to be marked on the component or its primary package shall be:

- (a) The ESCC qualified components symbol (for ESCC qualified components only).
- (b) The ESCC Component Number (see Para. 1.4.1).
- (c) Traceability information.

2.3 TERMINAL STRENGTH

The test conditions for terminal strength, tested as specified in the ESCC Generic Specification, shall be as follows:

- For TO-18, Test Condition: E, lead fatigue.

2.4 ELECTRICAL MEASUREMENTS AT ROOM, HIGH AND LOW TEMPERATURES

Electrical measurements shall be performed at room, high and low temperatures.

2.4.1 Room Temperature Electrical Measurements

The measurements shall be performed at $T_{amb} = +22 \pm 3^{\circ}\text{C}$.

Characteristics	Symbols	MIL-STD-750 Test Method	Test Conditions	Limits		Units
				Min	Max	
Collector-Emitter Breakdown Voltage	$V_{(BR)CEO}$	3011	$I_C = -10\text{mA}$ Note 1 Bias condition D	-60	-	V
Collector-Base Breakdown Voltage	$V_{(BR)CBO}$	3001	$I_E = -10\mu\text{A}$ Bias condition D	-60	-	V
Emitter-Base Breakdown Voltage	$V_{(BR)EBO}$	3026	$I_E = -10\mu\text{A}$ Bias condition D	-5	-	V
Collector-Emitter Cut-off Current	I_{CEX}	3041	$V_{CE} = -30\text{V}$ $V_{BE} = 500\text{mV}$ Bias condition C	-	-50	nA
Collector-Base Cut-off Current	I_{CBO}	3036	$V_{CB} = -50\text{V}$ Bias condition D	-	-10	nA
Forward-Current Transfer Ratio	h_{FE1}	3076	$V_{CE} = -10\text{V}$, $I_C = -100\mu\text{A}$	75	-	-
	h_{FE2}		$V_{CE} = -10\text{V}$, $I_C = -10\text{mA}$	100	-	-
	h_{FE3}		$V_{CE} = -10\text{V}$, $I_C = -150\text{mA}$ Note 1	100	300	-
	h_{FE4}		$V_{CE} = -10\text{V}$, $I_C = -500\text{mA}$ Note 1	50	-	-
Collector-Emitter Saturation Voltage	$V_{CE(sat)}$	3071	$I_C = -150\text{mA}$ $I_B = -15\text{mA}$ Note 1	-	-400	mV
Base-Emitter Saturation Voltage	$V_{BE(sat)}$	3066	$I_C = -150\text{mA}$ $I_B = -15\text{mA}$ Test condition A Note 1	-	-1.3	V
Magnitude of Small-Signal Short-Circuit Forward-Current Transfer Ratio	$ h_{fe} $	3306	$I_C = -20\text{mA}$, $V_{CE} = -20\text{V}$ $f = 100\text{MHz}$ Notes 2, 3	2	-	-
Output Capacitance	C_{obo}	3236	$V_{CB} = -10\text{V}$, $I_E = 0\text{mA}$ $100\text{kHz} \leq f \leq 1\text{MHz}$ Notes 2, 3	-	8	pF
Turn-on Time	t_{on}	-	$V_{CC} = -30\text{V}$ $I_C = -150\text{mA}$ $I_B = -15\text{mA}$ Notes 2, 3, 4	-	45	ns

Characteristics	Symbols	MIL-STD-750 Test Method	Test Conditions	Limits		Units
				Min	Max	
Turn-off Time	t_{off}	-	$V_{CC} = -30V$ $I_C = -150mA$ $I_B = -15mA$ Notes 2, 3, 5	-	300	ns

NOTES:

1. Pulse measurement: Pulse Width $\leq 300\mu s$, Duty Cycle $\leq 1\%$
2. For Packaged Components (Variants 01, 02, 04, 05, 06, 07) all AC characteristics read and record measurements shall be performed on a sample of 32 components with 0 failures allowed. Alternatively a 100% inspection may be performed.
3. For Die Components (Variants 08, 09) all AC characteristics read and record measurements shall be performed on either a sample of 32 components or 100% of the Packaged Test Sublot, whichever is less, with 0 failures allowed.
4. t_{on} shall be measured using the following test circuit. The input waveform shall be supplied by a pulse generator with the following characteristics: $Z_{OUT} = 50\Omega$, $t_r \leq 2ns$, Pulse Width = $200 \pm 10ns$, Duty Cycle $\leq 2\%$. The output waveform shall be monitored on an oscilloscope with the following characteristics: $Z_{IN} \geq 100k\Omega$, input capacitance $\leq 12pF$, $t_r \leq 5ns$.

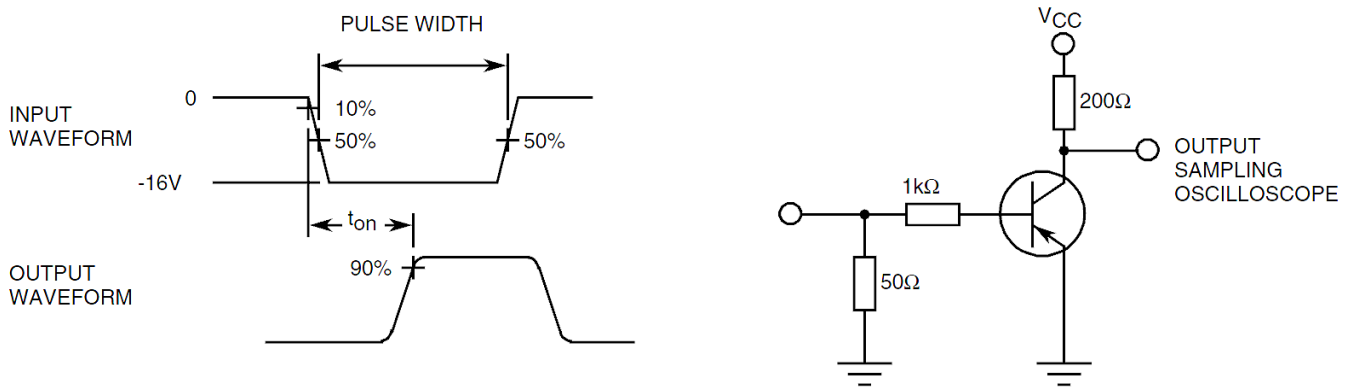

5. t_{off} shall be measured using the following test circuit. The input waveform shall be supplied by a pulse generator with the following characteristics: $Z_{OUT} = 50\Omega$, $t_r \leq 2ns$, Pulse Width = 10 to $100\mu s$, Duty Cycle $\leq 2\%$. The output waveform shall be monitored on an oscilloscope with the following characteristics: $Z_{IN} \geq 100k\Omega$, input capacitance $\leq 12pF$, $t_r \leq 5ns$.

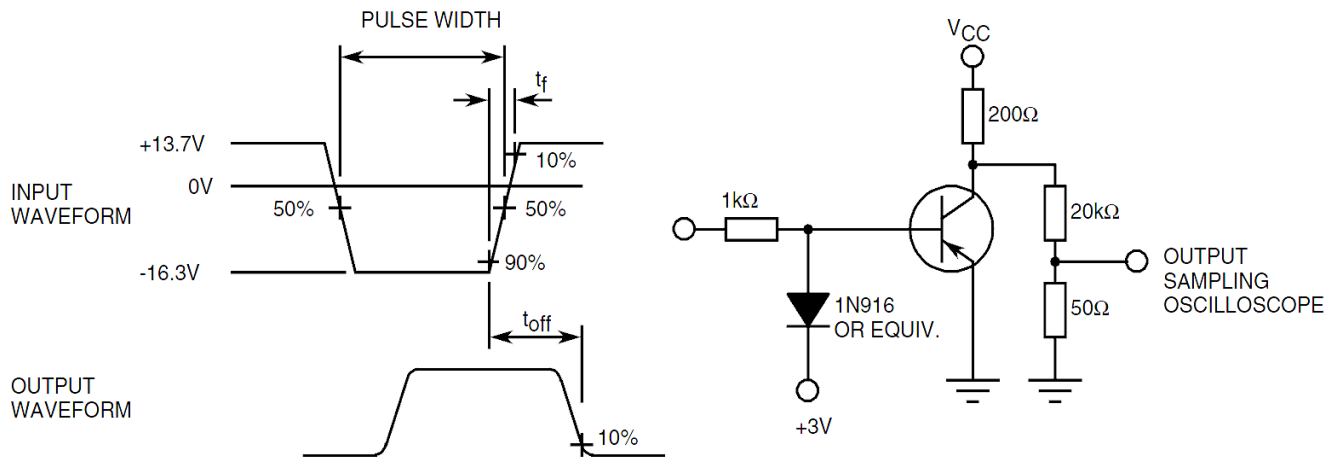

2.4.2 High and Low Temperatures Electrical Measurements

Characteristics	Symbols	MIL-STD-750 Test Method	Test Conditions Note 1	Limits		Units
				Min	Max	
Collector-Base Cut-off Current	I _{CB0}	3036	T _{amb} = +150 (+0 -5)°C V _{CB} = 50V, Bias Condition D	-	-10	µA

NOTES:

1. Measurements shall be performed on a sample basis as specified in the Generic Specification.

2.5 PARAMETER DRIFT VALUES

Unless otherwise specified, the measurements shall be performed at T_{amb} = +22 ±3°C.

The test methods and test conditions shall be as per the corresponding test defined in Para. 2.4.1, Room Temperature Electrical Measurements.

The drift values (Δ) shall not be exceeded for each characteristic specified. The corresponding absolute limit values for each characteristic shall not be exceeded.

Characteristics	Symbols	Limits			Units
		Drift Value Δ	Absolute		
			Min	Max	
Collector-Base Cut-off Current	I _{CB0}	±2 or (1) ±100%	-	-10	nA
Forward-Current Transfer Ratio 3	h _{FE3}	±15%	100	300	-
Collector-Emitter Saturation Voltage	V _{CE(sat)}	±50 or (1) ±15%	-	-400	mV

NOTES:

1. Whichever is the greater referred to the initial value.

2.6 INTERMEDIATE AND END-POINT ELECTRICAL MEASUREMENTS

Unless otherwise specified, the measurements shall be performed at T_{amb} = +22 ±3°C.

The test methods and test conditions shall be as per the corresponding test defined in Para. 2.4.1, Room Temperature Electrical Measurements.

The limit values for each characteristic shall not be exceeded.

Characteristics	Symbols	Limits		Units
		Min	Max	
Collector-Base Cut-off Current	I _{CB0}	-	-10	nA
Forward-Current Transfer Ratio 3	h _{FE3}	100	300	-

Characteristics	Symbols	Limits		Units
		Min	Max	
Collector-Emitter Saturation Voltage	$V_{CE(sat)}$	-	-400	mV

2.7 HIGH TEMPERATURE REVERSE BIAS BURN-IN CONDITIONS

Characteristics	Symbols	Test Conditions	Units
Ambient Temperature	T_{amb}	+150 (+0 -5)	°C
Collector-Base Voltage	V_{CB}	-50	V
Duration	t	48 minimum	Hours

2.8 POWER BURN-IN CONDITIONS

Characteristics	Symbols	Test Conditions	Units
Ambient Temperature	T_{amb}	+20 to +50	°C
Power Dissipation	P_{tot}	As per Para. 1.5, Maximum Ratings. Derate P_{tot1} at the chosen T_{amb} using the specified $R_{th(j-a)}$.	W
Collector-Base Voltage	V_{CB}	40	V

2.9 OPERATING LIFE CONDITIONS

The conditions shall be as specified in Para. 2.8, Power Burn-in Conditions.

2.10 TOTAL DOSE RADIATION TESTING

Total dose radiation testing is not applicable to Variant 09.

All lots of Variants 01, 02, 04, 05, 06, 07 and 08 shall be irradiated in accordance with ESCC Basic Specification No. 22900, low dose rate (window 2: 36rad(Si) to 360rad(Si) per hour).

2.10.1 Bias Conditions and Total Dose Level for Total Dose Radiation Testing

The following bias conditions shall be used for Total Dose Radiation Testing:

Characteristics	Symbols	Test Conditions	Units
Ambient Temperature	T_{amb}	+20 ±5	°C
Bias Condition 1: Collector-Emitter Voltage	V_{CES}	≥ 65% $V_{(BR)CEO}$	V
Bias Condition 2: Collector-Emitter Voltage	V_{CES}	0	V

The total dose level applied shall be as specified in Para. 1.4.2 or in the Purchase Order.

2.10.2 Electrical Measurements for Radiation Testing

Prior to irradiation testing the devices shall have successfully met Room Temperature Electrical Measurements specified in Para. 2.4.1.

Unless otherwise stated the measurements shall be performed at $T_{amb} = +22 \pm 3^{\circ}\text{C}$.

Unless otherwise specified the test methods and test conditions shall be as per the corresponding test defined in Para. 2.4.1, Room Temperature Electrical Measurements.

The parameters to be measured during and on completion of irradiation testing are shown below.

Characteristics	Symbols	MIL-STD-750 Test Method	Test Conditions	Limits		Units
				Min	Max	
Collector-Emitter Breakdown Voltage	$V_{(BR)CEO}$	See Para. 2.4.1	See Para. 2.4.1	-60	-	V
Collector-Base Breakdown Voltage	$V_{(BR)CBO}$	See Para. 2.4.1	See Para. 2.4.1	-60	-	V
Emitter-Base Breakdown Voltage	$V_{(BR)EBO}$	See Para. 2.4.1	See Para. 2.4.1	-5	-	V
Collector-Emitter Cut-off Current	I_{CEX}	See Para. 2.4.1	See Para. 2.4.1	-	-50	nA
Collector-Base Cut-off Current	I_{CBO}	See Para. 2.4.1	See Para. 2.4.1	-	-10	nA
Collector-Emitter Saturation Voltage	$V_{CE(sat)}$	See Para. 2.4.1	See Para. 2.4.1	-	-400	mV
Base-Emitter Saturation Voltage	$V_{BE(sat)}$	See Para. 2.4.1	See Para. 2.4.1	-	-1.3	V
Forward-Current Transfer Ratio (post irradiation gain calculation) (Note 1)	$[h_{FE1}]$	3076	$V_{CE} = -10\text{V}, I_C = -100\mu\text{A}$	[30]	-	-
	$[h_{FE2}]$		$V_{CE} = -10\text{V}, I_C = -10\text{mA}$	[50]	-	-
	$[h_{FE3}]$		$V_{CE} = -10\text{V}, I_C = -150\text{mA}$	[50]	300	-
	$[h_{FE4}]$		$V_{CE} = -10\text{V}, I_C = -500\text{mA}$	[25]	-	-

NOTES:

- The post-irradiation gain calculation of $[h_{FE}]$, made using h_{FE} measurements from prior to and on completion of irradiation testing and after each annealing step if any, shall be as specified in [MIL-STD-750 Method 1019](#).

APPENDIX 'A'
AGREED DEVIATIONS FOR STMICROELECTRONICS (F)

ITEMS AFFECTED	DESCRIPTION OF DEVIATIONS
Para. 2.1.1, Deviations from the Generic Specification: Para. 8, Test Methods and Procedures	For qualification and qualification maintenance, or procurement of qualified or unqualified components, the following replacement test method specifications shall be used instead of the following ESCC Basic Specifications: <ul style="list-style-type: none"> • No. 20400, Internal Visual Inspection: replaced by MIL-STD-750 Test Method 2072. • No. 20500, External Visual Inspection: replaced by MIL-STD-750 Test Method 2071. • No. 20900, Radiographic Inspection of Electronic Components: replaced by MIL-STD-750 Test Method 2076.
Para. 2.1.1, Deviations from the Generic Specification: Deviations from Production Control - Chart F2	Special In-Process Controls - Internal Visual Inspection. For CCP packages the criteria specified for voids in the fillet and minimum die mounting material around the visible die perimeter for die mounting defects may be omitted providing that a radiographic inspection to verify the die-attach process is performed on a sample basis in accordance with STMicroelectronics procedure 0076637.
Para. 2.1.1, Deviations from the Generic Specification: Deviations from Screening Tests - Chart F3	Solderability is not applicable unless specifically stipulated in the Purchase Order.
Para. 2.4.1, Room Temperature Electrical Measurements	All AC characteristics (Para. 2.4.1 Notes 2 and 3) may be considered guaranteed but not tested if successful pilot lot testing has been performed on the wafer lot which includes AC characteristic measurements per the Detail Specification. A summary of the pilot lot testing shall be provided if required by the Purchase Order.
Para. 2.4.2, High and Low Temperatures Electrical Measurements	All characteristics specified may be considered guaranteed but not tested if successful pilot lot testing has been performed on the wafer lot which includes characteristic measurements at high and low temperatures per the Detail Specification. A summary of the pilot lot testing shall be provided if required by the Purchase Order.