



TRANSISTORS, LOW POWER, NPN

BASED ON TYPE 2ST15300

ESCC Detail Specification No. 5201/020

Issue 2	October 2020
---------	--------------



LEGAL DISCLAIMER AND COPYRIGHT

European Space Agency, Copyright © 2020. All rights reserved.

The European Space Agency disclaims any liability or responsibility, to any person or entity, with respect to any loss or damage caused, or alleged to be caused, directly or indirectly by the use and application of this ESCC publication.

This publication, without the prior permission of the European Space Agency and provided that it is not used for a commercial purpose, may be:

- copied in whole, in any medium, without alteration or modification.
- copied in part, in any medium, provided that the ESCC document identification, comprising the ESCC symbol, document number and document issue, is removed.

DOCUMENTATION CHANGE NOTICE

(Refer to <https://escies.org> for ESCC DCR content)

DCR No.	CHANGE DESCRIPTION
1365, 1378	Specification upissued to incorporate changes per DCR.

TABLE OF CONTENTS

1	GENERAL	5
1.1	SCOPE	5
1.2	APPLICABLE DOCUMENTS	5
1.3	TERMS, DEFINITIONS, ABBREVIATIONS, SYMBOLS AND UNITS	5
1.4	THE ESCC COMPONENT NUMBER AND COMPONENT TYPE VARIANTS	5
1.4.1	The ESCC Component Number	5
1.4.2	Component Type Variants	5
1.5	MAXIMUM RATINGS	6
1.6	PHYSICAL DIMENSIONS AND TERMINAL IDENTIFICATION	7
1.6.1	Surface Mount Package (SMD.5) - 3 terminal	7
1.7	FUNCTIONAL DIAGRAM	7
1.8	MATERIALS AND FINISHES	8
2	REQUIREMENTS	8
2.1	GENERAL	8
2.1.1	Deviations from the Generic Specification	8
2.2	MARKING	8
2.3	TERMINAL STRENGTH	8
2.4	ELECTRICAL MEASUREMENTS AT ROOM, HIGH AND LOW TEMPERATURES	8
2.4.1	Room Temperature Electrical Measurements	9
2.4.2	High and Low Temperatures Electrical Measurements	11
2.5	PARAMETER DRIFT VALUES	11
2.6	INTERMEDIATE AND END-POINT ELECTRICAL MEASUREMENTS	11
2.7	HIGH TEMPERATURE REVERSE BIAS BURN-IN CONDITIONS	12
2.8	POWER BURN-IN CONDITIONS	12
2.9	OPERATING LIFE CONDITIONS	12
	APPENDIX A	14

1 GENERAL

1.1 SCOPE

This specification details the ratings, physical and electrical characteristics and test and inspection data for the component type variants and/or the range of components specified below. It supplements the requirements of, and shall be read in conjunction with, the ESCC Generic Specification listed under Applicable Documents.

1.2 APPLICABLE DOCUMENTS

The following documents form part of this specification and shall be read in conjunction with it:

- (a) ESCC Generic Specification No. [5000](#)
- (b) [MIL-STD-750](#), Test Methods and Procedures for Semiconductor Devices
- (c) [MIL-STD-883](#), Test Methods and Procedures for Micro-electronics.

1.3 TERMS, DEFINITIONS, ABBREVIATIONS, SYMBOLS AND UNITS

For the purpose of this specification, the terms, definitions, abbreviations, symbols and units specified in ESCC Basic Specification No. [21300](#) shall apply.

1.4 THE ESCC COMPONENT NUMBER AND COMPONENT TYPE VARIANTS

1.4.1 The ESCC Component Number

The ESCC Component Number shall be constituted as follows:

Example: 520102001

- Detail Specification Reference: 5201020
- Component Type Variant Number: 01 (as required)
- Total Dose Radiation Level Letter: R (as required)

1.4.2 Component Type Variants

The component type variants applicable to this specification are as follows:

Variant Number	Based on Type	Case	Terminal Material and Finish	Weight max g	Total Dose Radiation Level Letter
01	2ST15300	SMD.5	Q14	2	R [100krad(Si)]

The terminal material and finish shall be in accordance with the requirements of ESCC Basic Specification No. [23500](#).

Total dose radiation level letters are defined in ESCC Basic Specification No. [22900](#). If an alternative radiation test level is specified in the Purchase Order, the letter shall be changed accordingly.

1.5 MAXIMUM RATINGS

The maximum ratings shall not be exceeded at any time during use or storage.

Maximum ratings shall only be exceeded during testing to the extent specified in this specification and when stipulated in Test Methods and Procedures of the ESCC Generic Specification.

Characteristics	Symbols	Maximum Ratings	Units	Remarks
Collector-Base Voltage	V_{CBO}	300	V	Over entire operating temperature range
Collector-Emitter Voltage	V_{CEO}	100	V	
Emitter-Base Voltage	V_{EBO}	6	V	
Collector Current	I_C	5	A	Continuous
Power Dissipation	P_{tot1}	2.2	W	At $T_{amb} \leq +25^\circ\text{C}$ Note 1
	P_{tot2}	40	W	At $T_{case} \leq +25^\circ\text{C}$ Note 1
Thermal Resistance, Junction-to-Ambient	$R_{th(j-a)}$	80	$^\circ\text{C/W}$	
Thermal Resistance, Junction-to-Case	$R_{th(j-c)}$	4.38	$^\circ\text{C/W}$	
Junction Temperature	T_j	+200	$^\circ\text{C}$	
Operating Temperature Range	T_{op}	-65 to +200	$^\circ\text{C}$	
Storage Temperature Range	T_{stg}	-65 to +200	$^\circ\text{C}$	
Soldering Temperature	T_{sol}	+245	$^\circ\text{C}$	Note 2

NOTES:

1. For T_{amb} or $T_{case} > +25^\circ\text{C}$, derate linearly to 0W at +200 $^\circ\text{C}$.
2. Duration 5 seconds maximum and the same terminal shall not be resoldered until 3 minutes have elapsed.

1.6 PHYSICAL DIMENSIONS AND TERMINAL IDENTIFICATION

1.6.1 Surface Mount Package (SMD.5) - 3 terminal

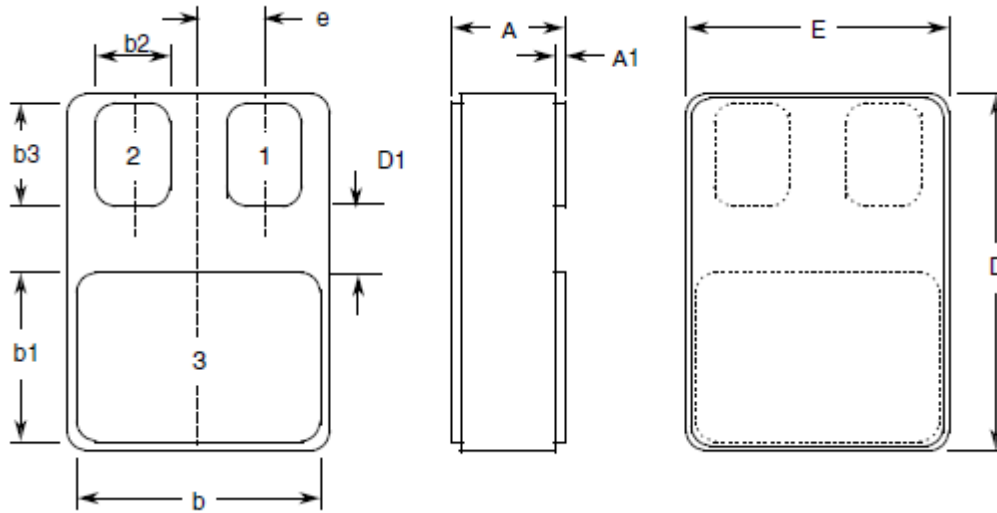

Symbols	Dimensions mm		Remarks
	Min	Max	
A	2.84	3.15	
A1	0.25	0.51	
b	7.13	7.39	
b1	5.58	5.84	
b2	2.28	2.54	2 places
b3	2.92	3.18	2 places
D	10.03	10.28	
D1	0.76	-	2 places
E	7.39	7.64	
e	1.91 BSC		2 places

NOTES:

- Terminal identification is specified by the components geometry where Terminal 1 = base, Terminal 2 = emitter and Terminal 3 = collector.

1.7 FUNCTIONAL DIAGRAM

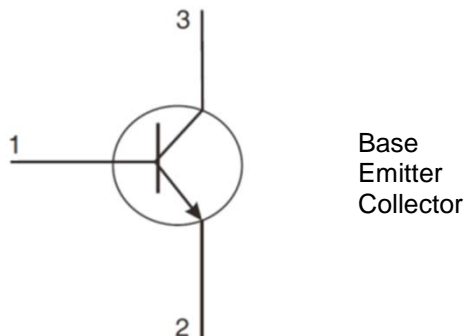

NOTES:

- The lid is not connected to any terminal.

1.8 MATERIALS AND FINISHES

Materials and finishes shall be as follows:

- (a) Case
The case shall be hermetically sealed and have a ceramic body with a Kovar lid.
- (b) Terminals
As specified in Para. 1.4.2 Component Type Variants.

2 REQUIREMENTS

2.1 GENERAL

The complete requirements for procurement of the components specified herein are as stated in this specification and the ESCC Generic Specification. Permitted deviations from the Generic Specification, applicable to this specification only, are listed below.

Permitted deviations from the Generic Specification and this Detail Specification, formally agreed with specific Manufacturers on the basis that the alternative requirements are equivalent to the ESCC requirement and do not affect the component's reliability, are listed in the appendices attached to this specification.

2.1.1 Deviations from the Generic Specification

None.

2.2 MARKING

The marking shall be in accordance with the requirements of ESCC Basic Specification No. [21700](#) and as follows.

The information to be marked on the component or its primary package shall be:

- (a) The ESCC qualified components symbol (for ESCC qualified components only).
- (b) The ESCC Component Number (see Para. 1.4.1).
- (c) Traceability information.

2.3 TERMINAL STRENGTH

The test conditions for terminal strength, tested as specified in the ESCC Generic Specification, shall be in accordance with [MIL-STD-883, Test Method 2004](#), Test Condition D.

2.4 ELECTRICAL MEASUREMENTS AT ROOM, HIGH AND LOW TEMPERATURES

Electrical measurements shall be performed at room, high and low temperatures.

2.4.1 Room Temperature Electrical Measurements

The measurements shall be performed at $T_{amb} = +22 \pm 3^{\circ}C$.

Characteristics	Symbols	MIL-STD-750 Test Method	Test Conditions	Limits		Units
				Min	Max	
Collector-Emitter Breakdown Voltage	$V_{(BR)CEO}$	3011	$I_C = 10mA$ Bias condition D Note 1	100	-	V
Collector-Base Breakdown Voltage	$V_{(BR)CBO}$	3001	$I_C = 10mA$ Bias condition D	300	-	V
Emitter-Base Breakdown Voltage	$V_{(BR)EBO}$	3026	$I_E = 10\mu A$ Bias condition D	6	-	V
Collector-Base Cut-off Current	I_{CBO}	3036	$V_{CE} = 300V$ Bias condition D	-	10	μA
Emitter-Base Cut-off Current	I_{EBO}	3061	$V_{EB} = 6V$ Bias condition D	-	50	μA
Forward-Current Transfer Ratio	h_{FE1}	3076	$V_{CE} = 0.6V; I_C = 50mA$	50	-	-
	h_{FE2}		$V_{CE} = 0.6V; I_C = 250mA$	55	-	-
	h_{FE3}		$V_{CE} = 5V; I_C = 1A$	55	-	-
	h_{FE4}		$V_{CE} = 5V; I_C = 5A$	35	-	-
Collector-Emitter Saturation Voltage	$V_{CE(sat)}$	3071	$I_C = 5A, I_B = 1A$ Note 1	-	0.7	V
Base-Emitter Saturation Voltage	$V_{BE(sat)}$	3066	$I_C = 5A, I_B = 1A$ Test condition A Note 1	-	1.4	V
Output Capacitance	C_{obo}	3236	$V_{CB} = 10V, I_E = 0A$ $f = 1MHz$ Note 2	-	120	pF
Turn-on Time	t_{on}	-	$V_{CC} = 30V, V_{BB} = -8V$ $I_C = 3A$	-	0.4	μs
Turn-off Time	t_{off}	-	$I_{B1} = I_{B2} = 300mA$ Notes 2, 3	-	3.5	μs

NOTES:

1. Pulse measurement: Pulse Width $\leq 300\mu s$, Duty Cycle $\leq 2\%$.
2. For AC characteristics, read and record measurements shall be performed on a sample of 32 components with 0 failures allowed. Alternatively a 100% inspection may be performed.

3. t_{on} and t_{off} shall be measured as follows:

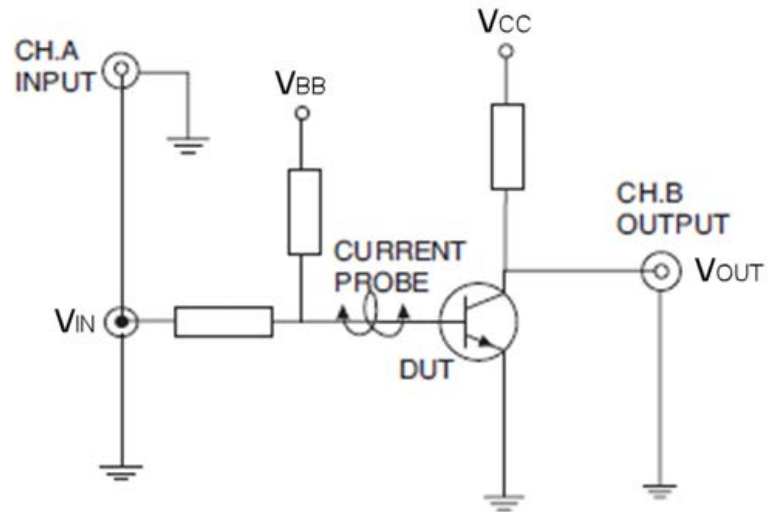

VOLTAGE WAVEFORMS

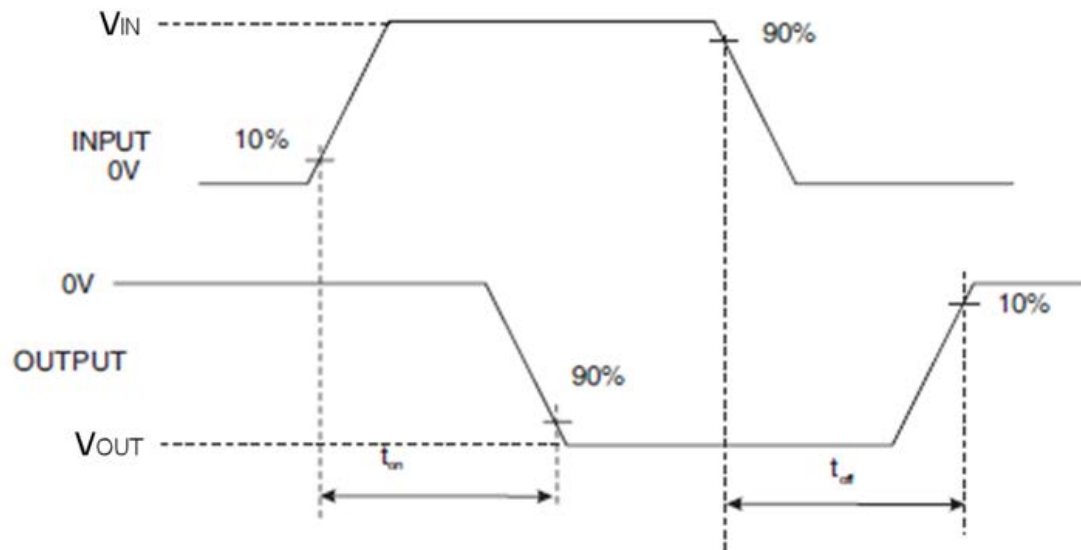

2.4.2 High and Low Temperatures Electrical Measurements

Characteristics	Symbols	MIL-STD-750 Test Method	Test Conditions Note 1	Limits		Units
				Min	Max	
Collector-Base Cut-off Current	I _{CB0}	3036	T _{amb} = +150 (+0 -5)°C V _{CB} = 300V Bias condition D	-	100	µA

NOTES:

1. Read and record measurements shall be performed on a sample of 5 components with 0 failures allowed. Alternatively a 100% inspection may be performed.

2.5 PARAMETER DRIFT VALUES

Unless otherwise specified, the measurements shall be performed at T_{amb} = +22 ±3°C.

The test methods and test conditions shall be as per the corresponding test defined in Para. 2.4.1 Room Temperature Electrical Measurements.

The drift values (Δ) shall not be exceeded for each characteristic specified. The corresponding absolute limit values for each characteristic shall not be exceeded.

Characteristics	Symbols	Limits			Units
		Drift Value Δ	Absolute		
			Min	Max	
Collector-Base Cut-off Current	I _{CB0}	±100 or (1) ±100%	-	10	µA
Collector-Emitter Saturation Voltage	V _{CE(sat)}	±30mV or (1) ±15%	-	0.7	V
Forward-Current Transfer Ratio 2	h _{FE2}	±15%	55	-	-

NOTES:

1. Whichever is the greater referred to initial value.

2.6 INTERMEDIATE AND END-POINT ELECTRICAL MEASUREMENTS

Unless otherwise specified, the measurements shall be performed at T_{amb} = +22 ±3°C.

The test methods and test conditions shall be as per the corresponding test defined in Para. 2.4.1 Room Temperature Electrical Measurements.

The limit values for each characteristic shall not be exceeded.

Characteristics	Symbols	Limits		Units
		Min	Max	
Collector-Base Cut-off Current	I _{CB0}	-	10	µA
Collector-Emitter Saturation Voltage	V _{CE(sat)}	-	0.7	V
Forward-Current Transfer Ratio 2	h _{FE2}	55	-	-

2.7 HIGH TEMPERATURE REVERSE BIAS BURN-IN CONDITIONS

Characteristics	Symbols	Test Conditions	Units
Ambient Temperature	T_{amb}	+150 (+0 -5)	°C
Collector-Base Voltage	V_{CB}	100	V
Duration	t	48 minimum	Hours

2.8 POWER BURN-IN CONDITIONS

Characteristics	Symbols	Test Conditions	Units
Ambient Temperature	T_{amb}	+20 to +50	°C
Power Dissipation	P_{tot}	As per Para. 1.5 Maximum Ratings. Derate P_{tot1} at the chosen T_{amb} using the specified $R_{th(j-a)}$.	W
Collector-Base Voltage	V_{CB}	20 to 50	V

2.9 OPERATING LIFE CONDITIONS

The conditions shall be as specified in Para. 2.8 Power Burn-in Conditions.

2.10 TOTAL DOSE RADIATION TESTING

All lots shall be irradiated in accordance with ESCC Basic Specification No. [22900](#), low dose rate (window 2: 36 to 360 rad(Si)/hour).

2.10.1 Bias Conditions and Total Dose Level for Total dose Radiation Testing

The following bias conditions shall be used for Total Dose Radiation Testing:

Characteristics	Symbols	Test Conditions	Units
Ambient Temperature	T_{amb}	+20 ±5	°C
Bias Condition 1: Collector-Emitter Voltage	V_{CES}	≥ 80% $V_{(BR)CEO}$	V
Bias Condition 2: Collector-Emitter Voltage	V_{CES}	0	V

The total dose level applied shall be as specified in Para. 1.4.2 or in the Purchase Order.

2.10.2 Electrical Measurements for Radiation Testing

Prior to irradiation testing, the devices shall have successfully met Para. 2.4.1 Room Temperature Electrical Measurements.

Unless otherwise stated, the measurements shall be performed at $T_{amb} = +22 \pm 3^{\circ}C$.

Unless otherwise specified, the test methods and test conditions shall be as per the corresponding test defined in Para. 2.4.1 Room Temperature Electrical Measurements.

The parameters to be measured during and on completion of irradiation testing are shown below.

Characteristics	Symbols	MIL-STD-750 Test Method	Test Conditions	Limits		Units
				Min	Max	
Collector-Emitter Breakdown Voltage	$V_{(BR)CEO}$	See Para. 2.4.1	See Para. 2.4.1	100	-	V
Collector-Base Breakdown Voltage	$V_{(BR)CBO}$	See Para. 2.4.1	See Para. 2.4.1	240	-	V
Emitter-Base Breakdown Voltage	$V_{(BR)EBO}$	See Para. 2.4.1	See Para. 2.4.1	6	-	V
Collector-Base Cut-off Current	I_{CBO}	See Para. 2.4.1	See Para. 2.4.1	-	10	μA
Emitter-Base Cut-off Current	I_{EBO}	See Para. 2.4.1	See Para. 2.4.1	-	50	μA
Forward-Current Transfer Ratio (post irradiation gain calculation) (Note 1)	$[h_{FE1}]$	3076	$V_{CE} = 0.6V; I_C = 50mA$	[25]	-	-
	$[h_{FE2}]$		$V_{CE} = 0.6V; I_C = 250mA$	[27.5]	-	-
	$[h_{FE3}]$		$V_{CE} = 5V; I_C = 1A$	[27.5]	-	-
	$[h_{FE4}]$		$V_{CE} = 5V; I_C = 5A$	[17.5]	-	-
Collector-Emitter Saturation Voltage	$V_{CE(sat)}$	See Para. 2.4.1	See Para. 2.4.1	-	0.7	V
Base-Emitter Saturation Voltage	$V_{BE(sat)}$	See Para. 2.4.1	See Para. 2.4.1	-	1.4	V

NOTES:

1. The post-irradiation gain calculation of $[h_{FE}]$, made using h_{FE} measurements from prior to and on completion of irradiation testing and after each annealing step if any, shall be as specified in [MIL-STD-750 Method 1019](#).

APPENDIX A
AGREED DEVIATIONS FOR STMICROELECTRONICS (F)

ITEMS AFFECTED	DESCRIPTION OF DEVIATIONS
Para. 2.1.1, Deviations from the Generic Specification: Para. 8, Test Methods and Procedures	For qualification and qualification maintenance, or procurement of qualified or unqualified components, the following replacement test method specifications shall be used instead of the following ESCC Basic Specifications: <ul style="list-style-type: none"> • No. 20400, Internal Visual Inspection: replaced by MIL-STD-750 Test Method 2072. • No. 20500, External Visual Inspection: replaced by MIL-STD-750 Test Method 2071. • No. 20900, Radiographic Inspection of Electronic Components: replaced by MIL-STD-750 Test Method 2076.
Para. 2.1.1, Deviations from the Generic Specification: Deviations from Screening Tests - Chart F3	Solderability is not applicable unless specifically stipulated in the Purchase Order.
Para. 2.4.1, Room Temperature Electrical Measurements	All AC characteristics (see Para. 2.4.1 Note 2) may be considered guaranteed but not tested if successful pilot lot testing has been performed on the wafer lot which includes AC characteristic measurements per the Detail Specification. A summary of the pilot lot testing shall be provided if required by the Purchase Order.
Para. 2.4.2, High and Low Temperatures Electrical Measurements	All characteristics specified may be considered guaranteed but not tested if successful pilot lot testing has been performed on the wafer lot which includes characteristic measurements at high and low temperatures per the Detail Specification. A summary of the pilot lot testing shall be provided if required by the Purchase Order.