



**INTEGRATED CIRCUITS, SILICON MONOLITHIC,
BIPOLAR DUAL MONOSTABLE
MULTIVIBRATORS,
BASED ON TYPE 54LS123
ESCC Detail Specification No. 9207/002**

**ISSUE 1
October 2002**



	ESCC Detail Specification		PAGE ii ISSUE 1
--	---------------------------	--	--------------------

LEGAL DISCLAIMER AND COPYRIGHT

European Space Agency, Copyright © 2002. All rights reserved.

The European Space Agency disclaims any liability or responsibility, to any person or entity, with respect to any loss or damage caused, or alleged to be caused, directly or indirectly by the use and application of this ESCC publication.

This publication, without the prior permission of the European Space Agency and provided that it is not used for a commercial purpose, may be:

- copied in whole in any medium without alteration or modification.
- copied in part, in any medium, provided that the ESCC document identification, comprising the ESCC symbol, document number and document issue, is removed.



europaean space agency
agence spatiale européenne

Pages 1 to 30

**INTEGRATED CIRCUITS, SILICON MONOLITHIC,
BIPOLAR DUAL MONOSTABLE
MULTIVIBRATORS,
BASED ON TYPE 54LS123
ESA/SCC Detail Specification No. 9207/002**



**space components
coordination group**

Issue/Rev.	Date	Approved by	
		SCCG Chairman	ESA Director General or his Deputy
Issue 4	July 1992	<i>Pommes</i>	<i>[Signature]</i>
Revision 'A'	January 1995	<i>Pommes</i>	<i>[Signature]</i>



DOCUMENTATION CHANGE NOTICE

Rev. Letter	Rev. Date	Reference	CHANGE Item	Approved DCR No.
		This issue supersedes Issue 3 and incorporates all modifications agreed on the basis of the following DCR's:-		
		Cover page		None
		DCN		None
		Table 1(a)	: Lead Material and/or Finish amended for existing Variants	22881
			: Variants 11 and 12 added	22881
		Figures 2(a), (b), (c)	: Imperial dimensions deleted	22881
		Figures 2(b), (c)	: Reference to Note 6 amended to "Note 10"	23519
		Figure 2(d)	: New figure added	22881
		Notes to Figures	: Title of the notes amended	22881
			: Note 1, last sentence added	22881
			: Note 8, 'or terminals' added	22881
			: Note 9, rewritten	22881
			: Notes 11 and 12 added	22881
		Figure 3(a)	: Figure for chip carrier package added	22881
			: Subtitles added above both drawings	22881
			: CLR changed to CLR	None
			: Comparison table added	22881
			: Note 1 added	22881
		Figure 3(b)	: Note amended	23519
		Figure 3(c)	: 12Ω changed to 120Ω	None
		Para. 4.2.2	: PIND deviation deleted, "None" added	21048
		Para. 4.2.4	: Deviation deleted, "None" added	22919
		Para. 4.2.5	: Deviation deleted, "None" added	22919
		Para. 4.3.2	: Paragraph rewritten	23460
		Para. 4.4.2	: Paragraph rewritten	22881
		Para. 4.5.2	: Paragraph rewritten	22881
		Para. 4.5.3	: Paragraph standardised	23519
		Para. 4.6.3	: "...and functional test sequence..." deleted	23519
		Para. 4.7.1	: "T _{amb} " added before "... +22 ± 3°C"	23519
		Paras. 4.7.2 & 4.7.3	: In title and paragraph, "burn-in" amended to read "power burn-in"	23519
		Table 2	: Nos. 47 to 48, 49 to 50, Max. Limit amended	23391
		Para. 4.8	: Title amended	23519
'A'	Jan. '95	P1. Cover Page		None
		P2. DCN		None
		P6. Table 1(b)	: Nos. 2 and 3, Notes reference changed to "1" and "2" respectively.	23573
			: No. 6, Entry amended to include DIL and FP	23573
			: Notes renumbered to "2", "3" and "1" respectively and resequenced	23573
			: Old Note 2, new Note 3 amended	23573
			: New Note 4 added	23573
		P7. Figure 2(a)	: Drawing and Table amended	221033
		P8. Figure 2(b)	: Drawing and Table amended	221033
		P16. Para. 4.3.2	: Maximum weights amended	221047

**TABLE OF CONTENTS**

	<u>Page</u>
1. <u>GENERAL</u>	5
1.1 Scope	5
1.2 Component Type Variants	5
1.3 Maximum Ratings	5
1.4 Parameter Derating Information	5
1.5 Physical Dimensions	5
1.6 Pin Assignment	5
1.7 Truth Table	5
1.8 Circuit Schematic	5
1.9 Functional Diagram	5
2. <u>APPLICABLE DOCUMENTS</u>	15
3. <u>TERMS, DEFINITIONS, ABBREVIATIONS, SYMBOLS AND UNITS</u>	15
4. <u>REQUIREMENTS</u>	15
4.1 General	15
4.2 Deviations from Generic Specification	15
4.2.1 Deviations from Special In-process Controls	15
4.2.2 Deviations from Final Production Tests	15
4.2.3 Deviations from Burn-in Tests	15
4.2.4 Deviations from Qualification Tests	15
4.2.5 Deviations from Lot Acceptance Tests	15
4.3 Mechanical Requirements	16
4.3.1 Dimension Check	16
4.3.2 Weight	16
4.4 Materials and Finishes	16
4.4.1 Case	16
4.4.2 Lead Material and Finish	16
4.5 Marking	16
4.5.1 General	16
4.5.2 Lead Identification	16
4.5.3 The SCC Component Number	16
4.5.4 Traceability Information	17
4.6 Electrical Measurements	17
4.6.1 Electrical Measurements at Room Temperature	17
4.6.2 Electrical Measurements at High and Low Temperatures	17
4.6.3 Circuits for Electrical Measurements	17
4.7 Burn-in Tests	17
4.7.1 Parameter Drift Values	17
4.7.2 Conditions for Power Burn-in	17
4.7.3 Electrical Circuits for Power Burn-in	17
4.8 Environmental and Endurance Tests	28
4.8.1 Electrical Measurements on Completion of Environmental Tests	28
4.8.2 Electrical Measurements at Intermediate Points during Endurance Tests	28
4.8.3 Electrical Measurements on Completion of Endurance Tests	28
4.8.4 Conditions for Operating Life Tests	28
4.8.5 Electrical Circuits for Operating Life Tests	28
4.8.6 Conditions for High Temperature Storage Test	28



Page

TABLES

1(a)	Type Variants	6
1(b)	Maximum Ratings	6
2	Electrical Measurements at Room Temperature, D.C. Parameters	18
	Electrical Measurements at Room Temperature, A.C. Parameters	19
3	Electrical Measurements at High and Low Temperatures	20
4	Parameter Drift Values	26
5	Conditions for Power Burn-in and Operating Life Test	26
6	Electrical Measurements on Completion of Environmental Tests and at Intermediate Points and on Completion of Endurance Tests	29

FIGURES

1	Not applicable	N/A
2	Physical Dimensions	7
3(a)	Pin Assignment	12
3(b)	Truth Table	13
3(c)	Circuit Schematic	14
3(d)	Functional Diagram	14
4	Circuits for Electrical Measurements	21
5	Electrical Circuit for Power Burn-in and Operating Life Test	27

APPENDICES (Applicable to specific Manufacturers only)

'A'	Agreed Deviations for Texas Instruments (F)	30
-----	---	----

**1. GENERAL****1.1 SCOPE**

This specification details the ratings, physical and electrical characteristics, test and inspection data for a silicon monolithic, low power bipolar Schottky Dual Retriggerable Monostable Multivibrator, based on Type 54LS123. It shall be read in conjunction with ESA/SCC Generic Specification No. 9000, the requirements of which are supplemented herein.

1.2 COMPONENT TYPE VARIANTS

Variants of the basic type integrated circuits specified herein, which are also covered by this specification, are given in Table 1(a).

1.3 MAXIMUM RATINGS

The maximum ratings, which shall not be exceeded at any time during use or storage, applicable to the integrated circuits specified herein, are as scheduled in Table 1(b).

1.4 PARAMETER DERATING INFORMATION (FIGURE 1)

Not applicable.

1.5 PHYSICAL DIMENSIONS

The physical dimensions of the integrated circuits specified herein are shown in Figure 2.

1.6 PIN ASSIGNMENT

As per Figure 3(a).

1.7 TRUTH TABLE

As per Figure 3(b).

1.8 CIRCUIT SCHEMATIC

As per Figure 3(c).

1.9 FUNCTIONAL DIAGRAM

As per Figure 3(d).

**TABLE 1(a) - TYPE VARIANTS**

VARIANT	CASE	FIGURE	LEAD MATERIAL AND/OR FINISH
01	FLAT	2(a)	D7
02	FLAT	2(a)	G4
05	DIL	2(b)	D7
06	DIL	2(b)	G4
07	DIL	2(c)	D7
08	DIL	2(c)	D3 or D4
11	CCP	2(d)	7
12	CCP	2(d)	4

TABLE 1(b) - MAXIMUM RATINGS

No.	CHARACTERISTICS	SYMBOL	MAXIMUM RATINGS	UNIT	REMARKS
1	Supply Voltage	V_{CC}	-0.5 to 7.0	V	-
2	Input Voltage	V_{IN}	-0.5 to 7.0	V	Note 1
3	Device Dissipation	P_D	110	mWdc	Note 2
4	Operating Temperature Range	T_{op}	-55 to +125	°C	-
5	Storage Temperature Range	T_{stg}	-65 to +150	°C	-
6	Soldering Temperature For FP and DIL For CCP	T_{sol}	+265 +245	°C	Note 3 Note 4

NOTES

1. Input current limited to -18mA.
2. Must withstand added PD due to short circuit conditions (i.e. IOS) at one output for 5 seconds.
3. Duration 10 seconds maximum at a distance of not less than 1.5mm from the device body and the same lead shall not be resoldered until 3 minutes have elapsed.
4. Duration 5 seconds maximum and the same terminal shall not be resoldered until 3 minutes have elapsed.



FIGURE 2 - PHYSICAL DIMENSIONS

FIGURE 2(a) - FLAT PACKAGE

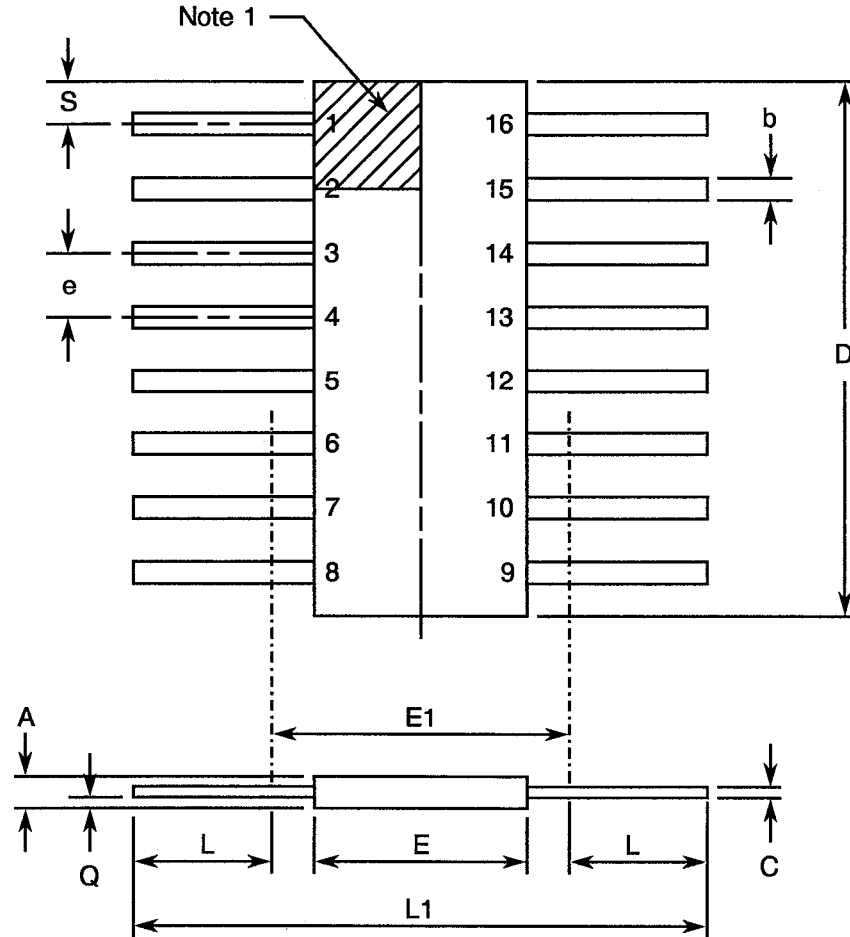

SYMBOL	MILLIMETRES		NOTES
	MIN	MAX	
A	1.27	2.03	
b	0.38	0.56	8
C	0.08	0.23	8
D	9.42	10.16	4
E	6.27	7.24	
E1	7.00 TYPICAL		4
e	1.27 TYPICAL		5, 9
L	7.87	8.89	8
L1	23.88	24.38	
Q	0.51	1.02	2
S	0.25	0.64	7

NOTES: See Page 11.



FIGURE 2 - PHYSICAL DIMENSIONS (CONTINUED)

FIGURE 2(b) - DUAL-IN-LINE PACKAGE

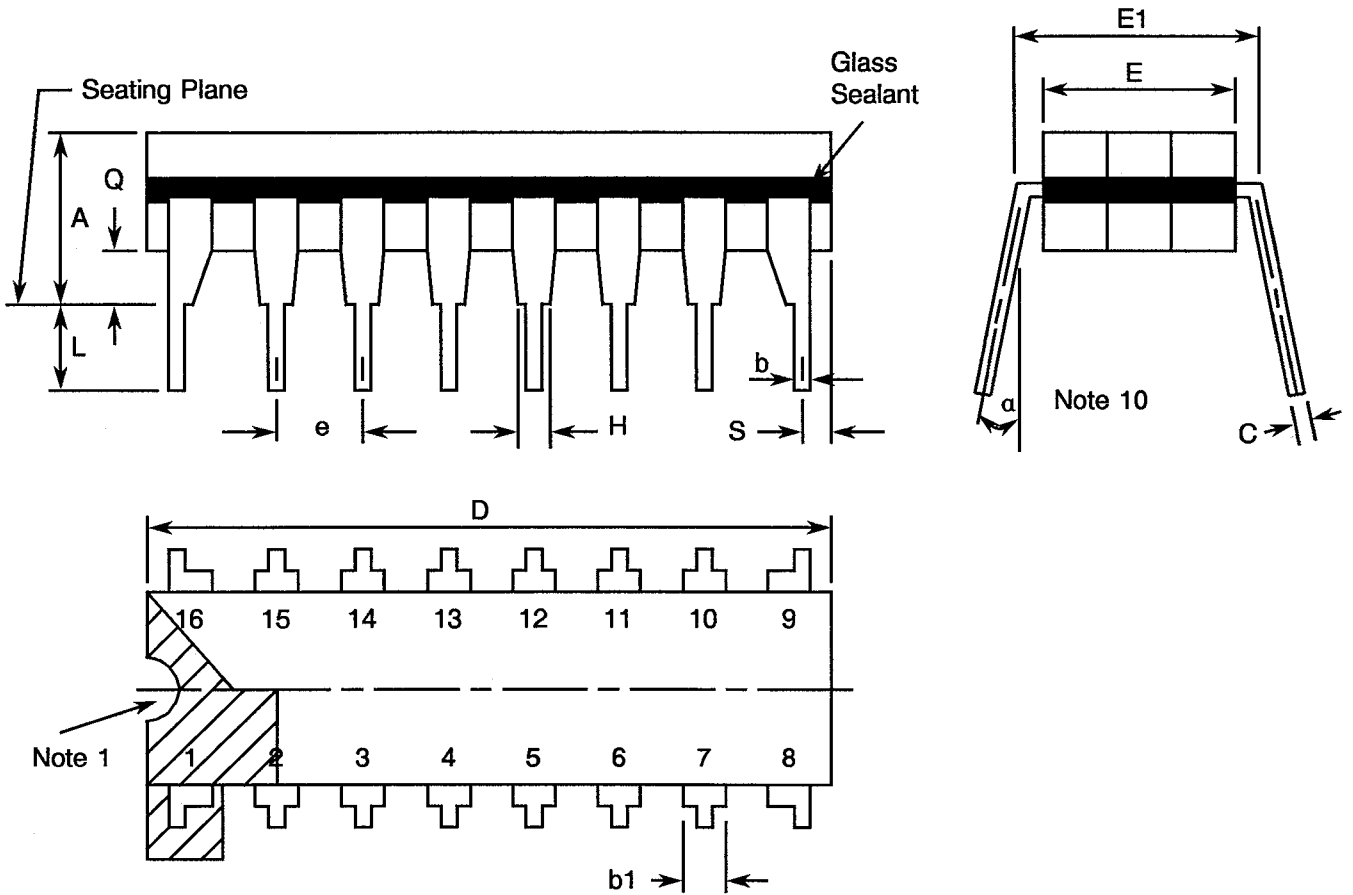

SYMBOL	MILLIMETRES		NOTES
	MIN	MAX	
A	-	5.08	
b	0.38	0.66	8
b1	-	1.78	8
C	0.20	0.44	8
D	19.18	19.94	4
E	6.22	7.62	4
E1	7.37	8.13	
e	2.54 TYPICAL		6, 9
F	1.27 TYPICAL		
H	0.76	-	
L	3.30	5.08	8
Q	0.51	-	3
S	0.38	1.27	7
a	0°	15°	10

NOTES: See Page 11.



FIGURE 2 - PHYSICAL DIMENSIONS (CONTINUED)

FIGURE 2(c) - DUAL-IN-LINE PACKAGE

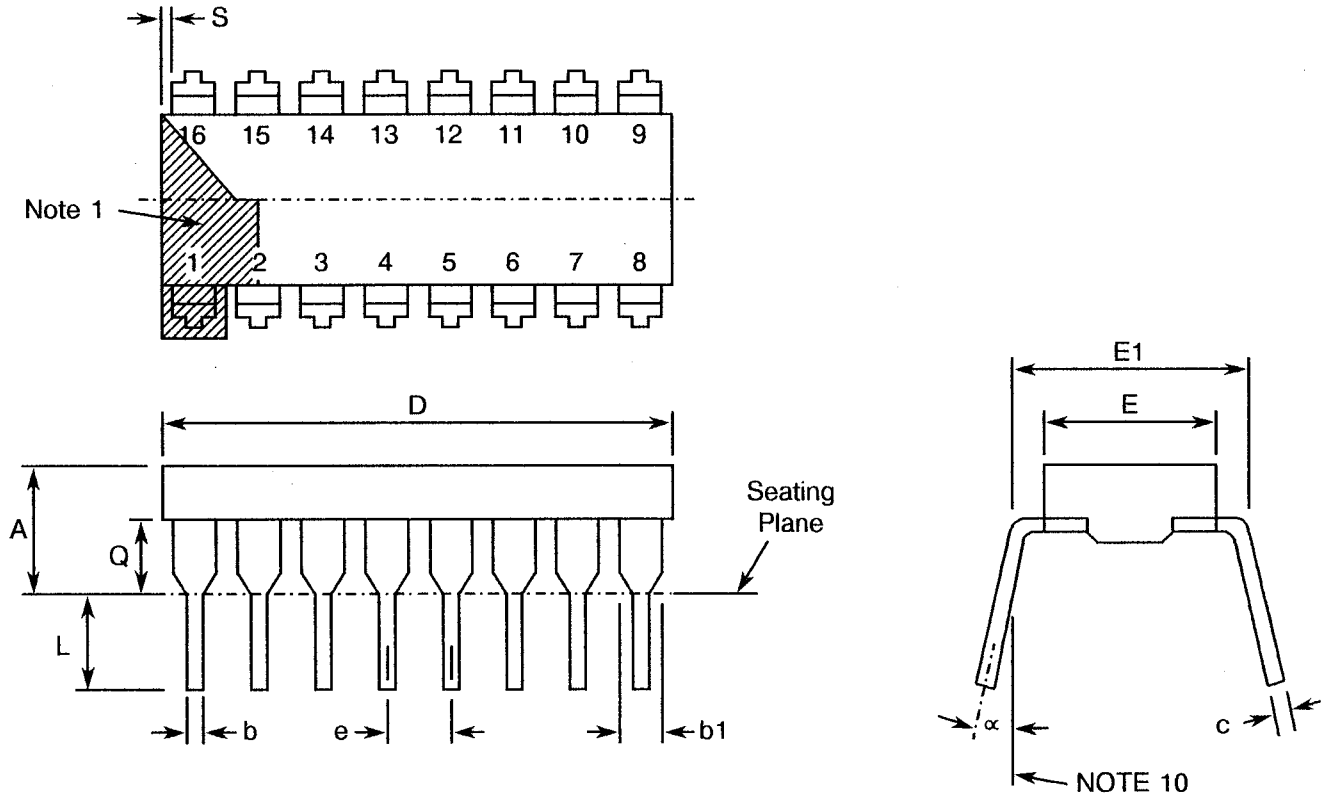

SYMBOL	MILLIMETRES		NOTES
	MIN.	MAX.	
A	-	5.08	-
b	0.36	0.58	8
b1	0.76	1.78	8
c	0.20	0.38	8
D	18.80	22.10	-
E	5.59	7.87	-
E1	7.37	8.13	4
e	2.54 TYPICAL		6, 9
L	3.18	5.08	-
Q	0.38	2.03	3
S	0.25	1.35	7
α	0°	15°	10

NOTES: See Page 11.



FIGURE 2 - PHYSICAL DIMENSIONS (CONTINUED)

FIGURE 2(d) - SQUARE CHIP CARRIER PACKAGE (3 LAYER BASE)

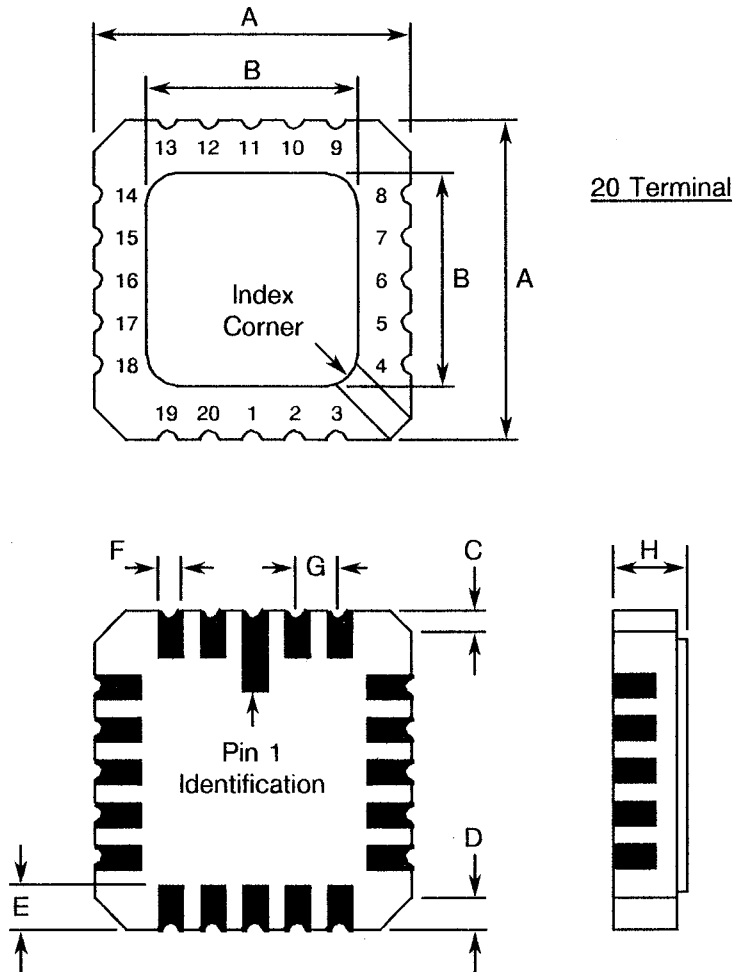

SYMBOL	MILLIMETRES		NOTES
	MIN.	MAX.	
A	8.687	9.093	-
B	7.798	9.093	-
C	0.250	0.510	11
D	0.889	1.143	12
E	1.140	1.400	8
F	0.559	0.712	8
G	1.27 TYPICAL		5, 9
H	1.630	2.540	-

NOTES: See Page 11.

**SCC**ESA/SCC Detail Specification
No. 9207/002

PAGE 11

ISSUE 4

FIGURE 2 - PHYSICAL DIMENSIONS (CONTINUED)**NOTES TO FIGURES 2(a) TO 2(d)**

1. Index area; a notch or a dot shall be located adjacent to Pin 1 and shall be within the shaded area shown. For chip carrier packages, the index shall be as shown in Figure 2(d).
2. Dimension Q shall be measured at the point of exit of the lead from the body.
3. Dimension Q shall be measured from the seating plane to the base plane.
4. This dimension allows for off-centre lids, meniscus and glass overrun.
5. The true position pin spacing is 1.27mm between centrelines. Each pin centreline shall be located within $\pm 0.13\text{mm}$ of its true longitudinal position relative to Pins 1 and 16 .
6. The true position pin spacing is 2.54mm between centrelines. Each pin centreline shall be located within $\pm 0.25\text{mm}$ of its true longitudinal position relative to Pins 1 and 16.
7. Applies to all four corners.
8. All leads or terminals.
9. 14 spaces for flat and dual-in-line packages.
16 spaces for chip carrier packages.
10. Lead centre when α is 0° .
11. Index corner only - 2 dimensions.
12. 3 non-index corners - 6 dimensions.

FIGURE 3(a) - PIN ASSIGNMENT

DUAL-IN-LINE AND FLAT PACKAGE

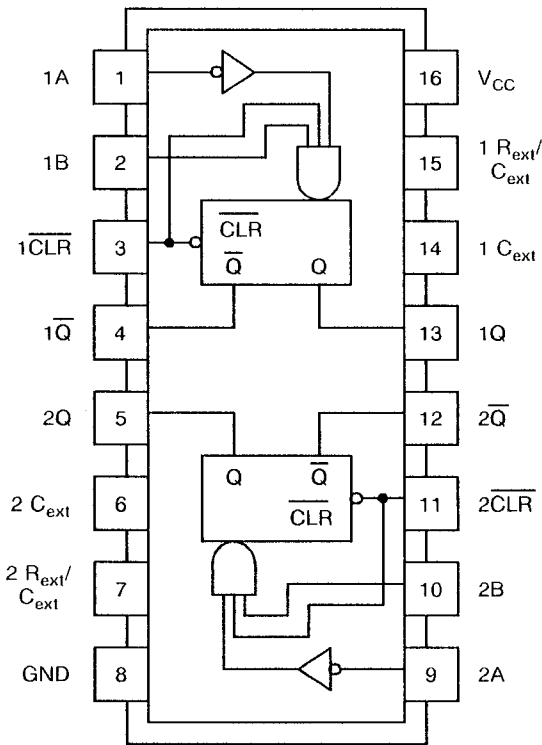

(TOP VIEW)

CHIP CARRIER PACKAGE

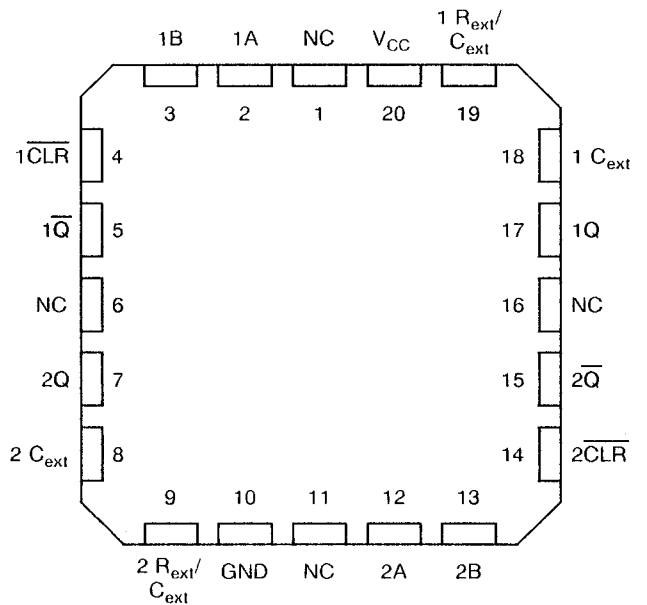

(TOP VIEW)







FLAT PACKAGE AND DUAL-IN-LINE TO CHIP CARRIER PIN ASSIGNMENT

FLAT PACKAGE AND DUAL-IN-LINE PIN OUTS	1	2	3	4	5	6	7	8	9	10	11	12	13	14	15	16
CHIP CARRIER PIN OUTS	2	3	4	5	7	8	9	10	12	13	14	15	17	18	19	20

NOTES

1. All references throughout this specification relate to FLAT/DIL packages only.

**FIGURE 3(b) - TRUTH TABLE (EACH MULTIVIBRATOR)**

INPUTS			OUTPUTS	
CLEAR	A	B	Q	\bar{Q}
L	X	X	L	H
X	H	X	L	H
X	X	L	L	H
H	L	↑		
H	↓	H		
↑	L	H		

NOTES



1. Logic Level Definitions: L = Low Level (Steady State), H = High Level (Steady State), X = Don't Care,  = one high level pulse,  = one low level pulse, ↑ = transition from low to high level, ↓ = transition from high to low level.



FIGURE 3(c) - CIRCUIT SCHEMATIC

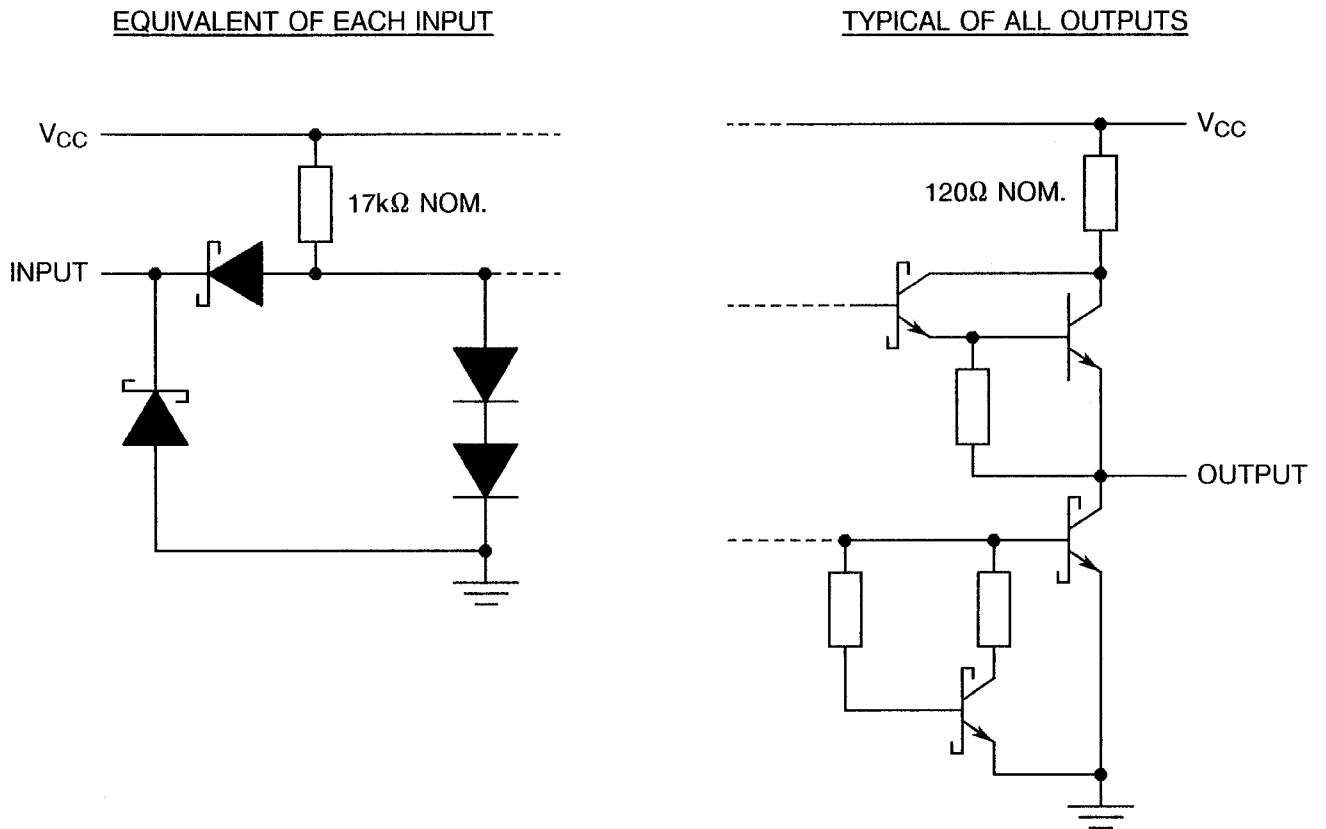
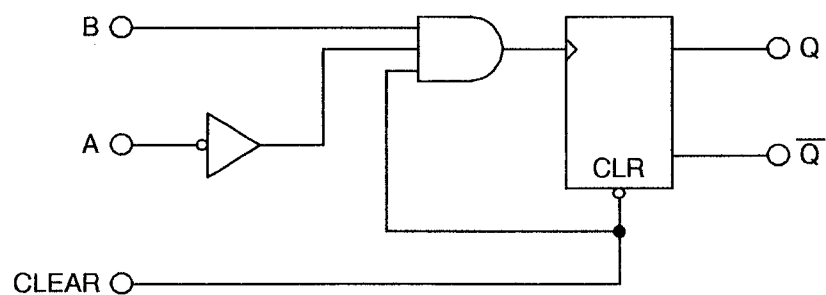

FIGURE 3(d) - FUNCTIONAL DIAGRAM (EACH MULTIVIBRATOR)



**2. APPLICABLE DOCUMENTS**

The following documents form part of this specification and shall be read in conjunction with it:-

- (a) ESA/SCC Generic Specification No. 9000 for Integrated Circuits.
- (b) MIL-STD-883, Test Methods and Procedures for Micro-electronics.

3. TERMS, DEFINITIONS, ABBREVIATIONS, SYMBOLS AND UNITS

For the purpose of this specification, the terms, definitions, abbreviations, symbols and units specified in ESA/SCC Basic Specification No. 21300 shall apply. In addition, the following abbreviation is used:-

- V_{IC} - Input Clamp Voltage.
- I_{CC} - Supply Current.
- V_{CC} - Supply Voltage.

4. REQUIREMENTS**4.1 GENERAL**

The complete requirements for procurement of the integrated circuits specified herein are stated in this specification and ESA/SCC Generic Specification No. 9000 for Integrated Circuits. Deviations from the Generic Specification applicable to this specification only, are listed in Para. 4.2.

Deviations from the applicable Generic Specification and this Detail Specification, formally agreed with specific Manufacturers on the basis that the alternative requirements are equivalent to the ESA/SCC requirements and do not affect the components' reliability, are listed in the appendices attached to this specification.

4.2 DEVIATIONS FROM GENERIC SPECIFICATION**4.2.1 Deviations from Special In-process Controls**

None.

4.2.2 Deviations from Final Production Tests (Chart II)

None.

4.2.3 Deviations from Burn-in Tests (Chart III)

- (a) Para. 7.1.1(a), High Temperature Reverse Bias tests and subsequent electrical measurements related to this test shall be omitted.
- (b) Para. 9.9.2, Electrical Measurements at High and Low Temperatures: Only a test result summary, based on go-no-go tests and presented in histogram form is required.

4.2.4 Deviations from Qualification Tests (Chart IV)

None.

4.2.5 Deviations from Lot Acceptance Tests (Chart V)

None.



4.3 MECHANICAL REQUIREMENTS

4.3.1 Dimension Check

The dimensions of the integrated circuits specified herein shall be checked. They shall conform to those shown in Figure 2.

4.3.2 Weight

The maximum weight of the integrated circuits specified herein shall be 0.7 grammes for the flat package, 2.2 grammes for the dual-in-line package and 0.6 grammes for the chip carrier package.

4.4 MATERIALS AND FINISHES

The materials and finishes shall be as specified herein. Where a definite material is not specified, a material which will enable the integrated circuits specified herein to meet the performance requirements of this specification shall be used. Acceptance or approval of any constituent material does not guarantee acceptance of the finished product.

4.4.1 Case

The case shall be hermetically sealed and have a metal body with hard glass seals or a ceramic body and the lids shall be welded, brazed, preform-soldered or glass frit-sealed.

4.4.2 Lead Material and Finish

For dual-in-line and flat packages, the material shall be either Type 'D' or Type 'G' with either Type '3 or 4', Type '4' or Type '7' finish in accordance with the requirements of ESA/SCC Basic Specification No. 23500. For chip carrier packages, the finish shall be either Type '4' or Type '7' in accordance with the requirements of ESA/SCC Basic Specification No. 23500. (See Table 1(a) for Type Variants).

4.5 MARKING

4.5.1 General

The marking of all components delivered to this specification shall be in accordance with the requirements of ESA/SCC Basic Specification No. 21700. Each component shall be marked in respect of:-

- (a) Lead Identification.
- (b) The SCC Component Number.
- (c) Traceability Information.

4.5.2 Lead Identification

For dual-in-line and flat packages, an index shall be located at the top of the package in the position defined in Note 1 to Figure 2 or, alternatively, a tab may be used to identify Pin No. 1. The pin numbering must be read with the index or tab on the left-hand side. For chip carrier packages, the index shall be as defined by Figure 2(d).

4.5.3 The SCC Component Number

Each component shall bear the SCC Component Number which shall be constituted and marked as follows:

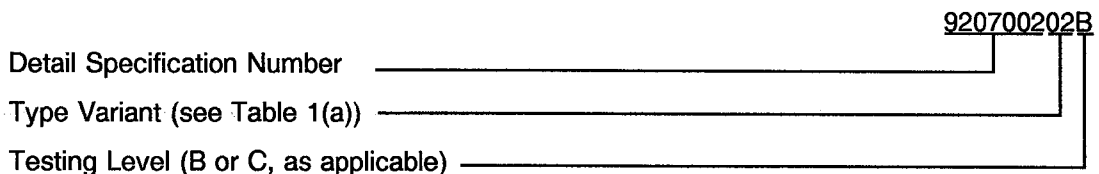



4.5.4 Traceability Information

Each component shall be marked in respect of traceability information in accordance with the requirements of ESA/SCC Basic Specification No. 21700.

4.6 ELECTRICAL MEASUREMENTS

4.6.1 Electrical Measurements at Room Temperature

The parameters to be measured in respect of electrical characteristics are scheduled in Table 2. Unless otherwise specified, the measurements shall be performed at $T_{amb} = +22 \pm 3$ °C.

4.6.2 Electrical Measurements at High and Low Temperatures

The parameters to be measured at high and low temperatures are scheduled in Table 3. The measurements shall be performed at $T_{amb} = +125$ and -55 °C respectively.

4.6.3 Circuits for Electrical Measurements

Circuits for use in performing the electrical measurements listed in Tables 2 and 3 of this specification are shown in Figure 4.

4.7 BURN-IN TESTS

4.7.1 Parameter Drift Values

The parameter drift values applicable to burn-in are specified in Table 4 of this specification. Unless otherwise stated, measurements shall be performed at $T_{amb} = +22 \pm 3$ °C. The parameter drift values (Δ) applicable to the parameters scheduled, shall not be exceeded. In addition to these drift value requirements, the appropriate limit value specified for a given parameter in Table 2 shall not be exceeded.

4.7.2 Conditions for Power Burn-in

The requirements for power burn-in are specified in Section 7 of ESA/SCC Generic Specification No. 9000. The conditions for power burn-in shall be as specified in Table 5 of this specification.

4.7.3 Electrical Circuits for Power Burn-in

Circuits for use in performing the power burn-in tests are shown in Figure 5 of this specification.



TABLE 2 - ELECTRICAL MEASUREMENTS AT ROOM TEMPERATURE - D.C. PARAMETERS

No.	CHARACTERISTICS	SYMBOL	TEST METHOD MIL-STD 883	TEST FIG.	TEST CONDITIONS (PINS UNDER TEST)	LIMITS		UNIT
						MIN	MAX	
1	Functional Test	-	-	3(b)	Verify Truth Table with Load. Note 1	-	-	-
2 to 7	Input Current High Level 1	I_{IH1}	3010	4(a)	$V_{CC} = 5.5V, V_{IN} = 2.7V$ (Pins 1-2-3-9-10-11)	-	20	μA
8 to 13	Input Current High Level 2 (Max. Input Voltage)	I_{IH2}	3010	4(a)	$V_{CC} = 5.5V, V_{IN} = 7.0V$ (Pins 1-2-3-9-10-11)	-	100	μA
14 to 19	Input Clamp Voltage	V_{IC}	3009	4(b)	$V_{CC} = 4.5V, I_{IN} = -18mA$ Note 2 (Pins 1-2-3-9-10-11)	-	-1.5	V
20 to 25	Input Current Low Level	I_{IL}	3009	4(c)	$V_{CC} = 5.5V, V_{IL} = 0.4V$ (Pins 1-2-3-9-10-11)	-	-400	μA
26 to 29	Output Voltage Low Level	V_{OL}	3007	4(d)	$V_{CC} = 4.5V, V_{IL} = 0.7V$ $V_{IH} = 2.0V, I_{OL} = 4.0mA$ (Pins 4-5-12-13)	-	0.4	V
30 to 33	Output Voltage High Level	V_{OH}	3006	4(e)	$V_{CC} = 4.5V, V_{IL} = 0.7V$ $V_{IH} = 2.0V, I_{OH} = -400\mu A$ (Pins 4-5-12-13)	2.5	-	V
34 to 37	Output Current Short Circuit	I_{OS}	3011	4(f)	$V_{CC} = 5.5V$ Note 3 (Pins 4-5-12-13)	-20	-100	mA
38	Supply Current Quiescent or Triggered	I_{CC}	3005	4(g)	$V_{CC} = 5.5V$ Note 4 (Pin 16)	-	20	mA

NOTES: See Page 19.

TABLE 2 - ELECTRICAL MEASUREMENTS AT ROOM TEMPERATURE - A.C. PARAMETERS

No.	CHARACTERISTICS	SYMBOL	TEST METHOD MIL-STD 883	TEST FIG.	TEST CONDITIONS (PINS UNDER TEST) (NOTE 5)	LIMITS		UNIT
						MIN	MAX	
39 to 40	Propagation Delay Low to High A to Q	t_{PLH1}	3003	4(h)	$V_{CC} = 5.0V, C_X = 0pF$ $C_L = 15pF, R_L = 2.0k\Omega$ $R_X = 5.0k\Omega$ (Pins 5-13)	-	33	ns
41 to 42	Propagation Delay Low to High B to Q	t_{PLH2}				-	44	
43 to 44	Propagation Delay High to Low A to \bar{Q}	t_{PHL1}	3003	4(h)	$V_{CC} = 5.0V, C_X = 0pF$ $C_L = 15pF, R_L = 2.0k\Omega$ $R_X = 5.0k\Omega$ (Pins 4-12)	-	45	ns
45 to 46	Propagation Delay High to Low B to \bar{Q}	t_{PHL2}				-	56	
47 to 48	Propagation Delay Low to High Clear to \bar{Q}	t_{PLH3}	3003	4(h)	$V_{CC} = 5.0V, C_X = 0pF$ $C_L = 15pF, R_L = 2.0k\Omega$ $R_X = 5.0k\Omega$ (Pins 4-12) (Pins 5-13)	-	45	ns
49 to 50	Propagation Delay High to Low Clear to Q	t_{PHL3}				-	27	
51 to 54	Output Pulse Width from A or B to Q	tw_Q (min)	3003	4(h)	$V_{CC} = 5.0V, C_X = 0pF$ $C_L = 15pF, R_L = 2.0k\Omega$ $R_X = 5.0k\Omega$ (Pins 5-13)	-	200	ns
		tw_Q	3003	4(h)	$V_{CC} = 5.0V, C_X = 1000pF$ $C_L = 15pF, R_L = 2.0k\Omega$ $R_X = 10k\Omega$ (Pins 5-13)	4	5	μs

NOTES

1. Go-no-go test with $V_{IL} = 0.3V$; $V_{IH} = 3.0V$; trip point 1.5V.
2. All inputs and outputs not under test shall be open.
3. No more than one output should be shorted at a time, and only for 1 second maximum.
4. With all outputs open and 4.5V applied to all data and clear inputs, I_{CC} shall be measured after a momentary ground; then 4.5V shall be applied to the clock.
5. Propagation delay measurements shall be performed as a go-no-go test on a 100% basis. Read-and-record measurements shall be performed on an LTPD7 sample basis following the Chart III Burn-in Test.

**TABLE 3 - ELECTRICAL MEASUREMENTS AT HIGH AND LOW TEMPERATURES,
+ 125(+ 0 - 5) °C AND - 55(+ 5 - 0) °C**

No.	CHARACTERISTICS	SYMBOL	TEST METHOD MIL-STD 883	TEST FIG.	TEST CONDITIONS (PINS UNDER TEST)	LIMITS		UNIT
						MIN	MAX	
1	Functional Test	-	-	3(b)	Verify Truth Table with Load. Note 1	-	-	-
2 to 7	Input Current High Level 1	I_{IH1}	3010	4(a)	$V_{CC} = 5.5V, V_{IN} = 2.7V$ (Pins 1-2-3-9-10-11)	-	20	μA
8 to 13	Input Current High Level 2 (Max. Input Voltage)	I_{IH2}	3010	4(a)	$V_{CC} = 5.5V, V_{IN} = 7.0V$ (Pins 1-2-3-9-10-11)	-	100	μA
14 to 19	Input Clamp Voltage	V_{IC}	3009	4(b)	$V_{CC} = 4.5V, I_{IN} = -18mA$ Note 2 (Pins 1-2-3-9-10-11)	-	- 1.5	V
20 to 25	Input Current Low Level	I_{IL}	3009	4(c)	$V_{CC} = 5.5V, V_{IL} = 0.4V$ (Pins 1-2-3-9-10-11)	-	- 400	μA
26 to 29	Output Voltage Low Level	V_{OL}	3007	4(d)	$V_{CC} = 4.5V, V_{IL} = 0.7V$ $V_{IH} = 2.0V, I_{OL} = 4.0mA$ (Pins 4-5-12-13)	-	0.4	V
30 to 33	Output Voltage High Level	V_{OH}	3006	4(e)	$V_{CC} = 4.5V, V_{IL} = 0.7V$ $V_{IH} = 2.0V, I_{OH} = -400\mu A$ (Pins 4-5-12-13)	2.5	-	V
34 to 37	Output Current Short Circuit	I_{OS}	3011	4(f)	$V_{CC} = 5.5V$ Note 3 (Pins 4-5-12-13)	- 20	- 100	mA
38	Supply Current Quiescent or Triggered	I_{CC}	3005	4(g)	$V_{CC} = 5.5V$ Note 4 (Pin 16)	-	20	mA

NOTES: See Page 19.



FIGURE 4 - CIRCUITS FOR ELECTRICAL MEASUREMENTS

FIGURE 4(a) - HIGH LEVEL INPUT CURRENT

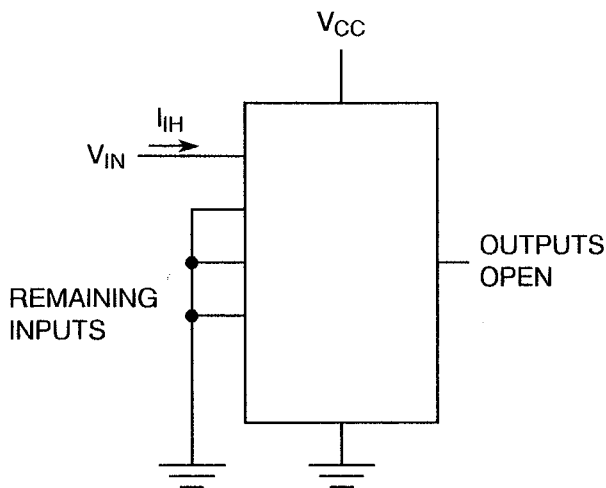

NOTES

- 1. Each input to be tested separately.

FIGURE 4(b) - INPUT CLAMP VOLTAGE

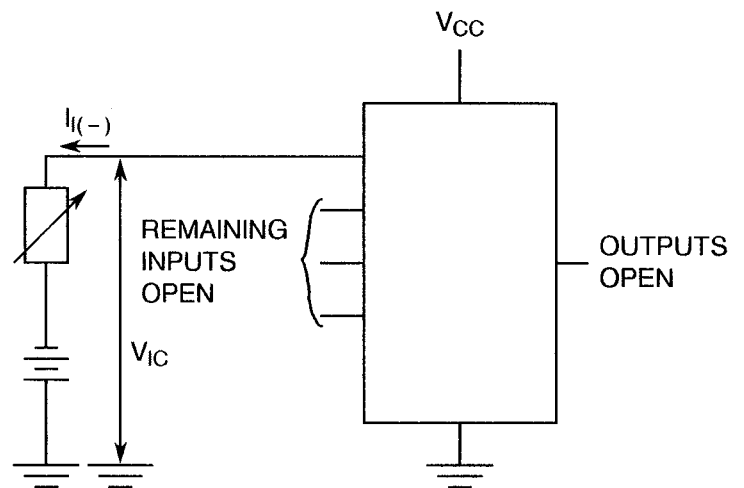

NOTES

- 1. Each input to be tested separately.

FIGURE 4(c) - LOW LEVEL INPUT CURRENT

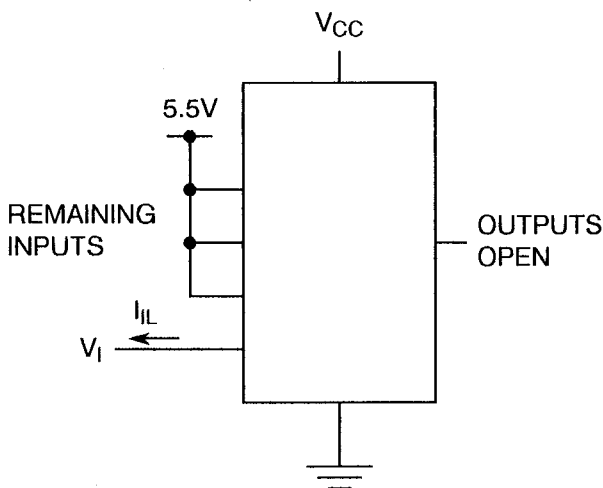

NOTES

- 1. Each input to be tested separately.

FIGURE 4(d) - LOW LEVEL OUTPUT VOLTAGE

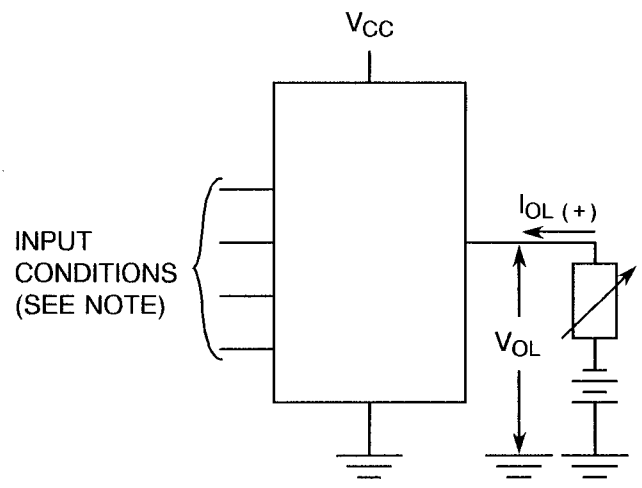

NOTES

- 1. Test per Truth Table.

FIGURE 4 - CIRCUITS FOR ELECTRICAL MEASUREMENTS (CONTINUED)

FIGURE 4(e) - HIGH LEVEL OUTPUT VOLTAGE

FIGURE 4(f) - SHORT CIRCUIT OUTPUT CURRENT

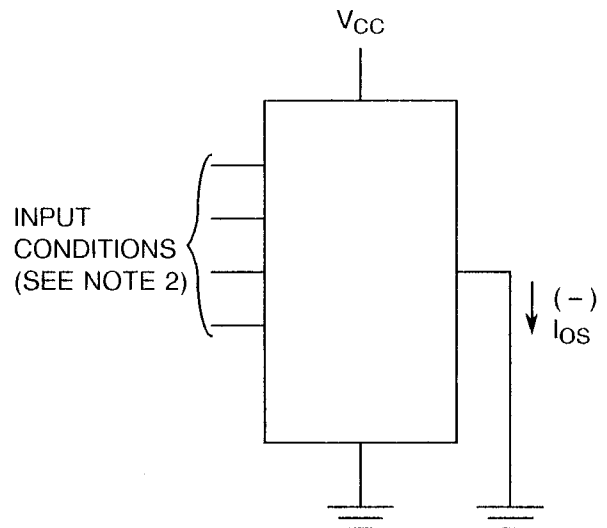
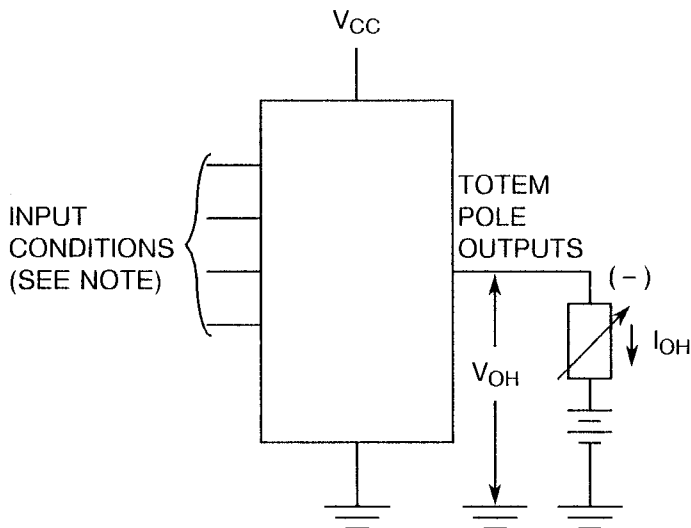

NOTES

1. Test per Truth Table.

NOTES

1. Test per Truth Table.
2. No more than one output to be shorted at a time.

FIGURE 4(g) - SUPPLY CURRENT

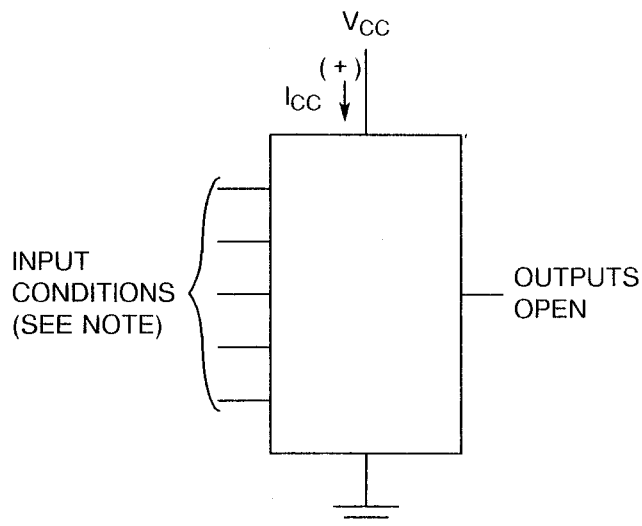

NOTES

1. See Note 4 for Table 2.



FIGURE 4 - CIRCUITS FOR ELECTRICAL MEASUREMENTS (CONTINUED)

FIGURE 4(h) - DYNAMIC TEST AND SWITCHING WAVEFORMS

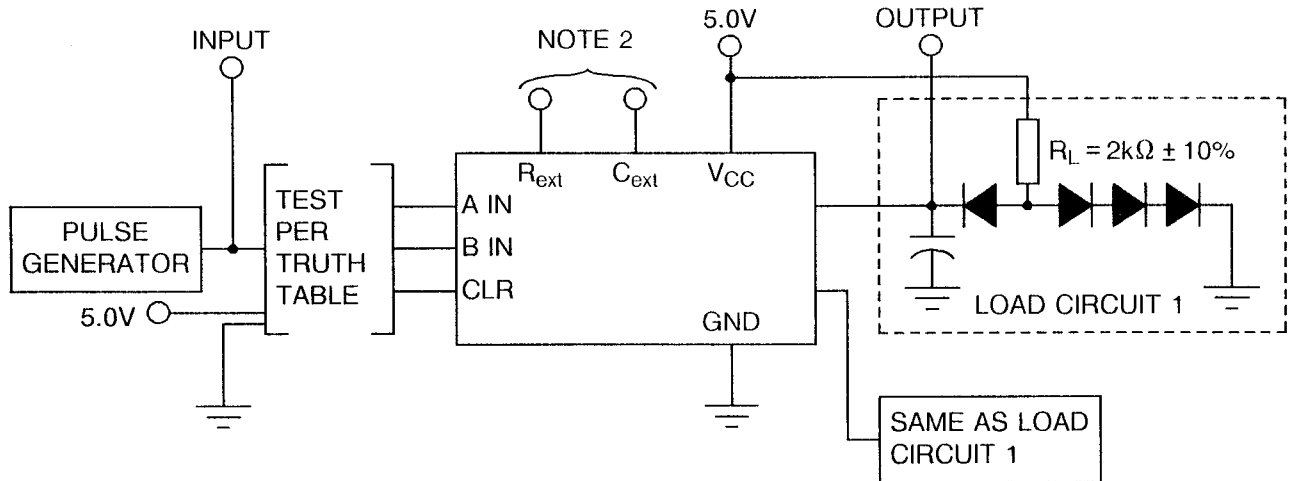

VOLTAGE WAVEFORMS

t_{PLH1} AND t_{w1} WAVEFORMS

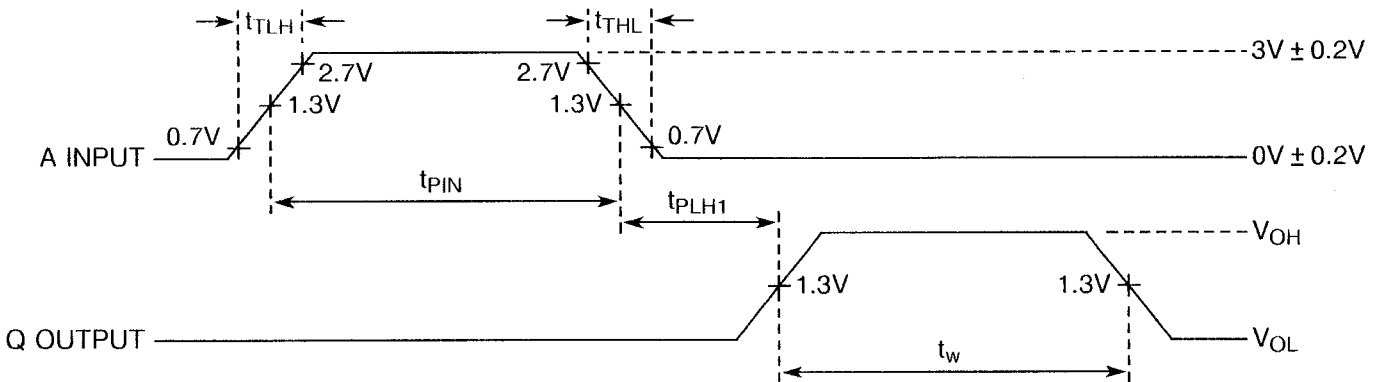

t_{PLH2} AND t_{w2} WAVEFORMS

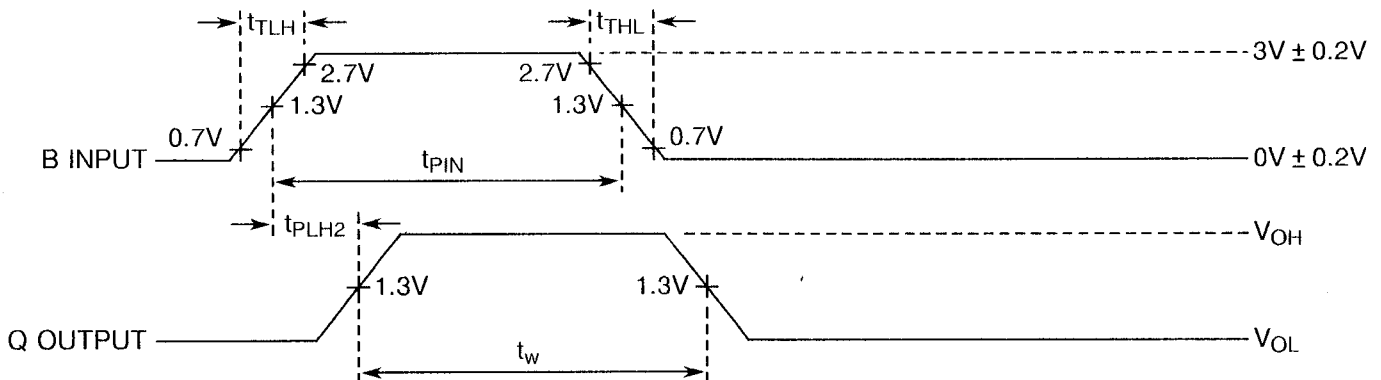



FIGURE 4 - CIRCUITS FOR ELECTRICAL MEASUREMENTS (CONTINUED)

VOLTAGE WAVEFORMS (CONTINUED)

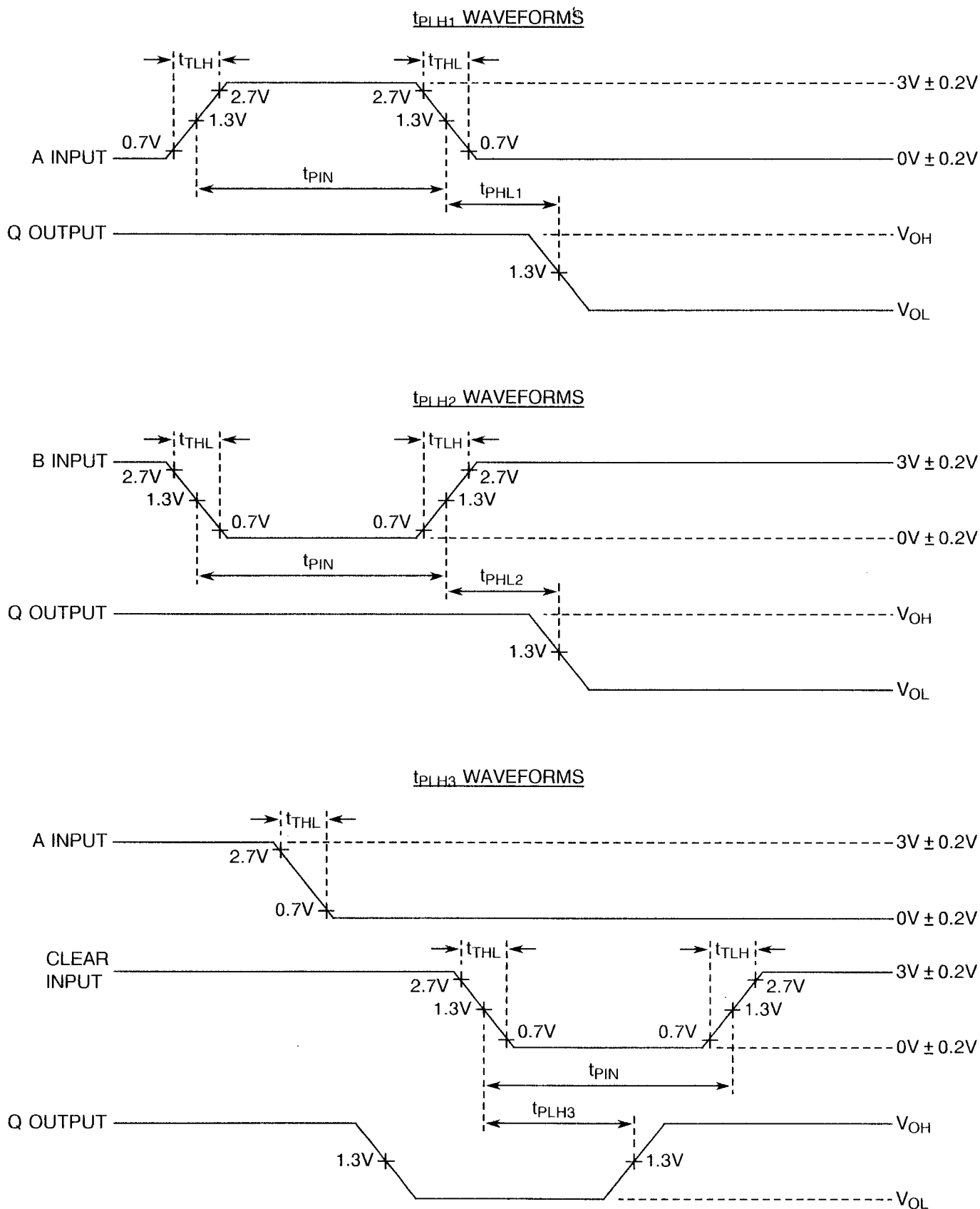
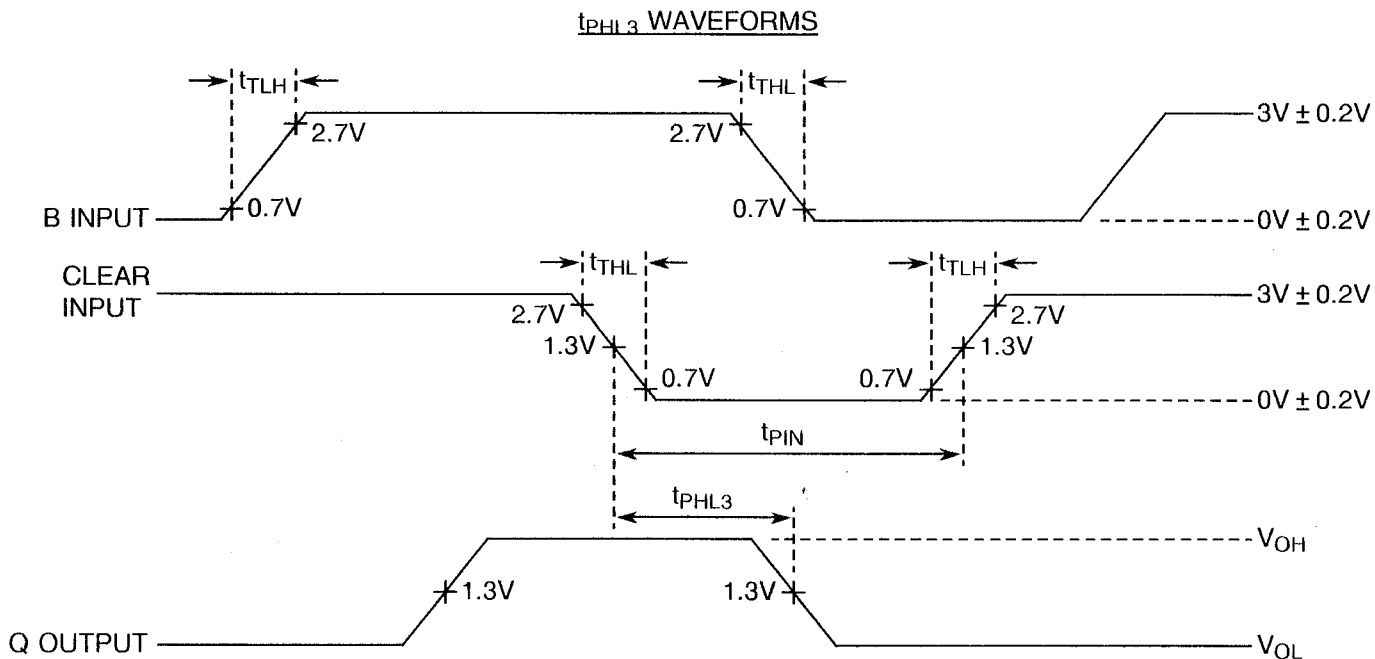



FIGURE 4 - CIRCUITS FOR ELECTRICAL MEASUREMENTS (CONTINUED)

VOLTAGE WAVEFORMS (CONTINUED)



NOTES

1. Pulse generator has the following characteristics: $PRR = 1.0MHz$, $t_{PIN} \geq 40ns$, $t_r < 6.0ns$, $t_f < 15ns$, and $Z_{out} = 50\Omega$.
2. See Table 2 for R_{ext} , C_{ext} values.
3. $C_L = 15pF \pm 10\%$ including scope probe, wiring and stray capacitance, without package in test fixture.
4. All diodes are 1N3064 or 1N916.

TABLE 4 - PARAMETER DRIFT VALUES

No.	CHARACTERISTICS	SYMBOL	SPEC. AND/OR TEST METHOD	TEST CONDITIONS	CHANGE LIMITS (Δ)	UNIT
2 to 7	Input Current High Level 1	I_{IH1}	As per Table 2	As per Table 2	± 20 or (1) ± 0.5	% μA
20 to 25	Input Current Low Level 1	I_{IL1}	As per Table 2	As per Table 2	± 18	μA
26 to 29	Output Voltage Low Level	V_{OL}	As per Table 2	As per Table 2	± 60	mV
30 to 33	Output Voltage High Level	V_{OH}	As per Table 2	As per Table 2	± 240	mV

NOTES

1. Whichever is greater, referred to the initial value.

TABLE 5 - CONDITIONS FOR POWER BURN-IN AND OPERATING LIFE TEST

No.	CHARACTERISTICS	SYMBOL	CONDITION	UNIT
1	Ambient Temperature	T_{amb}	+ 125(+ 0 - 5)	$^{\circ}C$
2	Power Supply Voltage	V_{CC}	+ 5(+ 0.5 - 0)	V
3	Pulse Voltage	V_{GEN}	0.5 max. to 3.0 min.	V
4	Frequency	f_{GEN1} f_{GEN2}	100 50 (See Note 1)	Hz
5	Fan-out	-	10	-
6	Rise Time	t_r	50 max.	μs
7	Fall Time	t_f	50 max.	μs
8	Duty Cycle	-	20 min.	%

NOTES

1. Tolerance $\pm 10\%$.



FIGURE 5 - ELECTRICAL CIRCUIT FOR POWER BURN-IN AND OPERATING LIFE TEST

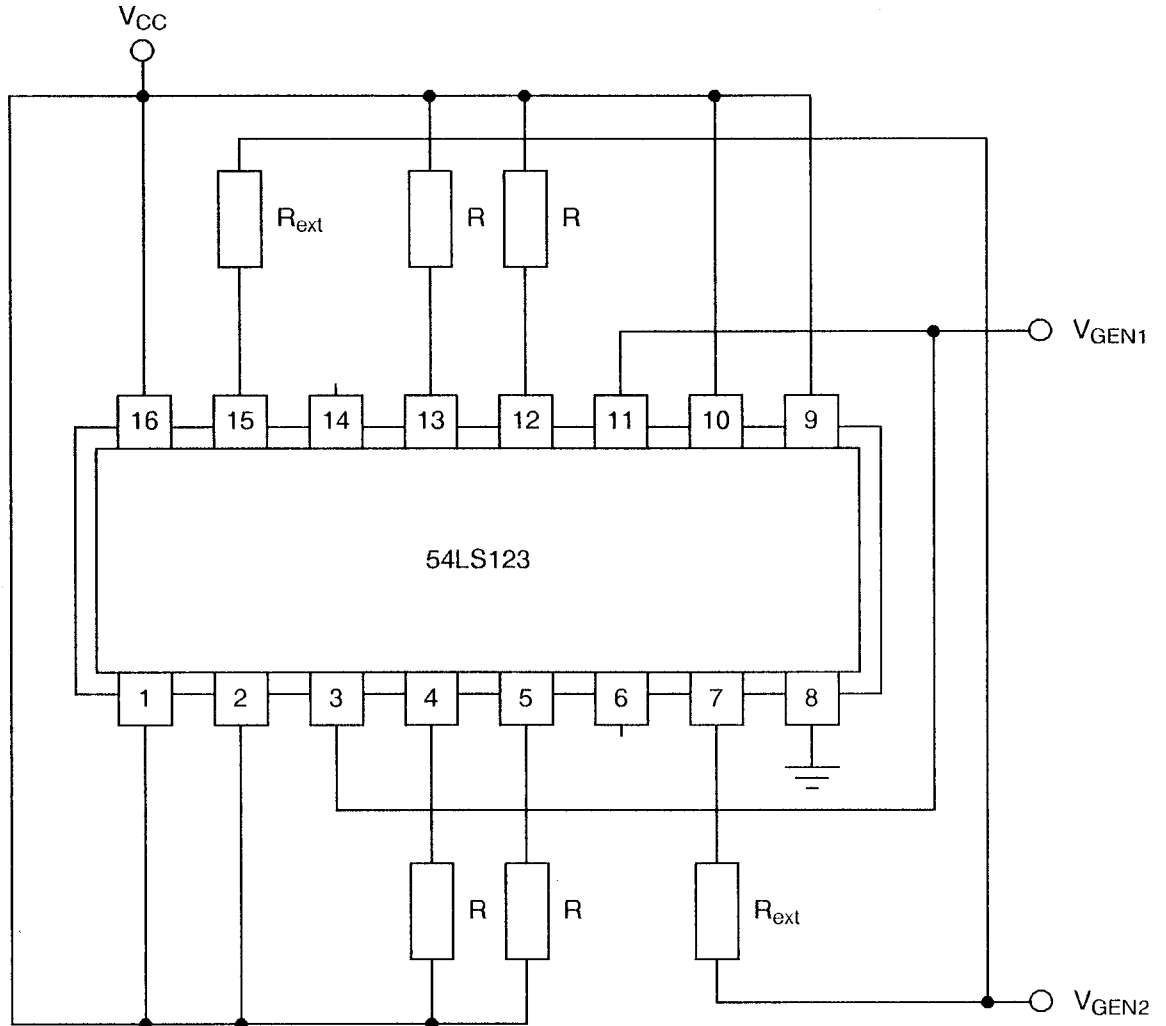

NOTES

1. $R = 1.2k\Omega$.



- 4.8 ENVIRONMENTAL AND ENDURANCE TESTS (CHARTS IV AND V OF ESA/SCC GENERIC SPECIFICATION NO. 9000)
- 4.8.1 Electrical Measurements on Completion of Environmental Tests
The parameters to be measured on completion of environmental tests are scheduled in Table 6. Unless otherwise stated, the measurements shall be performed at $T_{amb} = +22 \pm 3 \text{ }^\circ\text{C}$.
- 4.8.2 Electrical Measurements at Intermediate Points during Endurance Tests
The parameters to be measured at intermediate points during endurance tests are as scheduled in Table 6 of this specification.
- 4.8.3 Electrical Measurements on Completion of Endurance Tests
The parameters to be measured on completion of endurance testing are as scheduled in Table 6 of this specification. Unless otherwise stated, the measurements shall be performed at $T_{amb} = +22 \pm 3 \text{ }^\circ\text{C}$.
- 4.8.4 Conditions for Operating Life Tests
The requirements for operating life testing are specified in Section 9 of ESA/SCC Generic Specification No. 9000. The conditions for operating life testing shall be as specified in Table 5 of this specification.
- 4.8.5 Electrical Circuits for Operating Life Tests
Circuits for use in performing the operating life tests are shown in Figure 5.
- 4.8.6 Conditions for High Temperature Storage Test
The requirements for the high temperature storage test are specified in ESA/SCC Generic Specification No. 9000. The conditions for high temperature storage shall be $T_{amb} = +150(+0-5) \text{ }^\circ\text{C}$.

**TABLE 6 - ELECTRICAL MEASUREMENTS ON COMPLETION OF ENVIRONMENTAL TESTS AND AT INTERMEDIATE POINTS AND ON COMPLETION OF ENDURANCE TESTS**

No.	CHARACTERISTICS	SYMBOL	SPEC. AND/OR TEST METHOD	TEST CONDITIONS	CHANGE LIMITS		UNIT
					(Δ)	ABSOLUTE	
2 to 7	Input Current High Level 1	I_{IH1}	As per Table 2	As per Table 2	± 1.0	-	μA
8 to 13	Input Current High Level 2	I_{IH2}	As per Table 2	As per Table 2	-	100	μA
20 to 25	Input Current Low Level	I_{IL1}	As per Table 2	As per Table 2	± 12	-	μA
26 to 29	Output Voltage Low Level	V_{OL}	As per Table 2	As per Table 2	± 60	-	mV
30 to 33	Output Voltage High Level	V_{OH}	As per Table 2	As per Table 2	± 240	-	mV
38	Supply Current Quiescent or Triggered	I_{CCH}	As per Table 2	As per Table 2	± 20	-	%

 SCC	ESA/SCC Detail Specification No. 9207/002		PAGE 30 ISSUE 4
--	--	--	--------------------

APPENDIX 'A'

Page 1 of 1

AGREED DEVIATIONS FOR TEXAS INSTRUMENTS (F)

ITEMS AFFECTED	DESCRIPTION OF DEVIATIONS
Para. 4.2.1	Scanning Electron Microscope (SEM) Inspection may be performed using TIF document TIF 3.61.610.001.
Para. 4.2.2	Prior to Die Shear Test TIF may perform a Radiographic Inspection on the randomly chosen samples to be subjected to this test, using TIF document TIF 50.42-3002.
Para. 4.2.3	Radiographic Inspection may be performed using TIF document TIF 50.42-3002.