



**INTEGRATED CIRCUITS, SILICON MONOLITHIC,
BIPOLAR 4-BY-4 REGISTER FILES,
BASED ON TYPE 54LS670
ESCC Detail Specification No. 9301/001**

**ISSUE 1
October 2002**



	ESCC Detail Specification		PAGE ii ISSUE 1
---	---------------------------	--	--------------------

LEGAL DISCLAIMER AND COPYRIGHT

European Space Agency, Copyright © 2002. All rights reserved.

The European Space Agency disclaims any liability or responsibility, to any person or entity, with respect to any loss or damage caused, or alleged to be caused, directly or indirectly by the use and application of this ESCC publication.

This publication, without the prior permission of the European Space Agency and provided that it is not used for a commercial purpose, may be:

- copied in whole in any medium without alteration or modification.
- copied in part, in any medium, provided that the ESCC document identification, comprising the ESCC symbol, document number and document issue, is removed.



europaean space agency
agence spatiale européenne

Pages 1 to 33

**INTEGRATED CIRCUITS, SILICON MONOLITHIC,
BIPOLAR 4-BY-4 REGISTER FILES,
BASED ON TYPE 54LS670**

ESA/SCC Detail Specification No. 9301/001



**space components
coordination group**

Issue/Rev.	Date	Approved by	
		SCCG Chairman	ESA Director General or his Deputy
Issue 4	February 1994	<i>P. Monneret</i>	<i>J. L. ...</i>



DOCUMENTATION CHANGE NOTICE

Rev. Letter	Rev. Date	Reference	CHANGE Item	Approved DCR No.
		This issue supersedes Issue 3 and incorporates all modifications defined in Revisions 'A', 'B', 'C' and 'D' to Issue 3 and the following DCR's:-		
		Cover page		None
		DCN		None
		Table 1(a)	: Lead Material and/or Finish amended for existing Variants	22881
			: Variants 11 and 12 added	22881
		Table 1(b)	: No. 2, in Remarks, Note No. amended to "1"	23573
			: No. 3, in Remarks, Note No. amended to "2"	23573
			: No. 6, existing temperature specified for DIL/FP, new temperature and Note reference added for CCP	23573
			: Note 1 renumbered as "2"	23573
			: Note 2 renumbered as "3" and text amended	23573
			: Note 3 renumbered as "1"	23573
			: New Note 4 added	23573
		Figures 2(a), (b)	: Drawing and Table amended	221033
		Figures 2(a), (b), (c)	: Imperial dimensions deleted	22881
		Figures 2(b), (c)	: Reference to Note 6 amended to "Note 10"	23519
		Figure 2(d)	: New figure added	22881
		Notes to Figures	: Title of the notes amended	22881
			: Note 1, last sentence added	22881
			: Note 8, 'or terminals' added	22881
			: Note 9, rewritten	22881
			: Notes 11 and 12 added	22881
		Figure 3(a)	: Figure for chip carrier package added	22881
			: Subtitles added above both drawings	22881
			: Comparison table added	22881
			: Note 1 added	22881
		Para. 4.2.2	: PIND deviation deleted, "None" added	21048
		Para. 4.2.4	: Deviation deleted, "None" added	22919
		Para. 4.2.5	: Deviation deleted, "None" added	22919
		Para. 4.3.2	: Paragraph rewritten	23460
			: Maximum weight limits amended	221047
		Para. 4.4.2	: Paragraph rewritten	22881
		Para. 4.5.2	: Paragraph rewritten	22881
		Para. 4.5.3	: Paragraph standardised	23519
		Para. 4.6.3	: "...and functional test sequence..." deleted	23519
		Para. 4.7.1	: "T _{amb} " added before "... +22 ± 3°C"	23519
		Paras. 4.7.2 & 4.7.3	: In title and paragraph, "burn-in" amended to read "power burn-in"	23519
		Para. 4.8	: Title amended	23519



TABLE OF CONTENTS

	<u>Page</u>
1. <u>GENERAL</u>	5
1.1 Scope	5
1.2 Component Type Variants	5
1.3 Maximum Ratings	5
1.4 Parameter Derating Information	5
1.5 Physical Dimensions	5
1.6 Pin Assignment	5
1.7 Truth Table	5
1.8 Circuit Schematic	5
1.9 Functional Diagram	5
2. <u>APPLICABLE DOCUMENTS</u>	15
3. <u>TERMS, DEFINITIONS, ABBREVIATIONS, SYMBOLS AND UNITS</u>	15
4. <u>REQUIREMENTS</u>	15
4.1 General	15
4.2 Deviations from Generic Specification	15
4.2.1 Deviations from Special In-process Controls	15
4.2.2 Deviations from Final Production Tests	15
4.2.3 Deviations from Burn-in Tests	15
4.2.4 Deviations from Qualification Tests	15
4.2.5 Deviations from Lot Acceptance Tests	15
4.3 Mechanical Requirements	16
4.3.1 Dimension Check	16
4.3.2 Weight	16
4.4 Materials and Finishes	16
4.4.1 Case	16
4.4.2 Lead Material and Finish	16
4.5 Marking	16
4.5.1 General	16
4.5.2 Lead Identification	16
4.5.3 The SCC Component Number	17
4.5.4 Traceability Information	17
4.6 Electrical Measurements	17
4.6.1 Electrical Measurements at Room Temperature	17
4.6.2 Electrical Measurements at High and Low Temperatures	17
4.6.3 Circuits for Electrical Measurements	17
4.7 Burn-in Tests	17
4.7.1 Parameter Drift Values	17
4.7.2 Conditions for Power Burn-in	17
4.7.3 Electrical Circuits for Power Burn-in	17
4.8 Environmental and Endurance Tests	31
4.8.1 Electrical Measurements on Completion of Environmental Tests	31
4.8.2 Electrical Measurements at Intermediate Points during Endurance Tests	31
4.8.3 Electrical Measurements on Completion of Endurance Tests	31
4.8.4 Conditions for Operating Life Tests	31
4.8.5 Electrical Circuits for Operating Life Tests	31
4.8.6 Conditions for High Temperature Storage Test	31

TABLES

		<u>Page</u>
1(a)	Type Variants	6
1(b)	Maximum Ratings	6
2	Electrical Measurements at Room Temperature, D.C. Parameters	18
	Electrical Measurements at Room Temperature, A.C. Parameters	20
3	Electrical Measurements at High and Low Temperatures	21
4	Parameter Drift Values	29
5	Conditions for Power Burn-in and Operating Life Test	29
6	Electrical Measurements on Completion of Environmental Tests and at Intermediate Points and on Completion of Endurance Tests	32

FIGURES

1	Not applicable	N/A
2	Physical Dimensions	7
3(a)	Pin Assignment	12
3(b)	Truth Table	13
3(c)	Circuit Schematic	13
3(d)	Functional Diagram	14
4	Circuits for Electrical Measurements	23
5	Electrical Circuit for Power Burn-in and Operating Life Test	30

APPENDICES (Applicable to specific Manufacturers only)

'A'	Agreed Deviations for Texas Instruments (F)	33
-----	---	----

	<p style="text-align: center;">ESA/SCC Detail Specification No. 9301/001</p>	<p>PAGE 5 ISSUE 4</p>
---	--	---------------------------

1. GENERAL

1.1 SCOPE

This specification details the ratings, physical and electrical characteristics, test and inspection data for a silicon monolithic, low power bipolar Schottky 4-by-4 Register Files with 3-state outputs, based on Type 54LS670. It shall be read in conjunction with ESA/SCC Generic Specification No. 9000, the requirements of which are supplemented herein.

1.2 COMPONENT TYPE VARIANTS

Variants of the basic type integrated circuits specified herein, which are also covered by this specification, are given in Table 1(a).

1.3 MAXIMUM RATINGS

The maximum ratings, which shall not be exceeded at any time during use or storage, applicable to the integrated circuits specified herein, are as scheduled in Table 1(b).

1.4 PARAMETER DERATING INFORMATION (FIGURE 1)

Not applicable.

1.5 PHYSICAL DIMENSIONS

The physical dimensions of the integrated circuits specified herein are shown in Figure 2.

1.6 PIN ASSIGNMENT

As per Figure 3(a).

1.7 TRUTH TABLE

As per Figure 3(b).

1.8 CIRCUIT SCHEMATIC

As per Figure 3(c).

1.9 FUNCTIONAL DIAGRAM

As per Figure 3(d).

TABLE 1(a) - TYPE VARIANTS

VARIANT	CASE	FIGURE	LEAD MATERIAL AND/OR FINISH
01	FLAT	2(a)	D7
02	FLAT	2(a)	G4
05	DIL	2(b)	D7
06	DIL	2(b)	G4
07	DIL	2(c)	D7
08	DIL	2(c)	D3 or D4
11	CCP	2(d)	7
12	CCP	2(d)	4

TABLE 1(b) - MAXIMUM RATINGS

No.	CHARACTERISTICS	SYMBOL	MAXIMUM RATINGS	UNIT	REMARKS
1	Supply Voltage	V_{CC}	- 0.5 to 7.0	V	-
2	Input Voltage	V_{IN}	- 0.5 to 7.0	V	Note 1
3	Device Dissipation	P_D	275	mWdc	Note 2
4	Operating Temperature Range	T_{op}	- 55 to + 125	°C	-
5	Storage Temperature Range	T_{stg}	- 65 to + 150	°C	-
6	Soldering Temperature For FP and DIP For CCP	T_{sol}	+ 265 + 245	°C	Note 3 Note 4

NOTES

1. Input current limited to - 18mA.
2. Must withstand added P_D due to short circuit conditions (i.e. I_{OS}) at one output for 5 seconds.
3. Duration 10 seconds maximum at a distance of not less than 1.5mm from the device body and the same lead shall not be resoldered until 3 minutes have elapsed.
4. Duration 5 seconds maximum and the same terminal shall not be resoldered until 3 minutes have elapsed.



FIGURE 2 - PHYSICAL DIMENSIONS

FIGURE 2(a) - FLAT PACKAGE

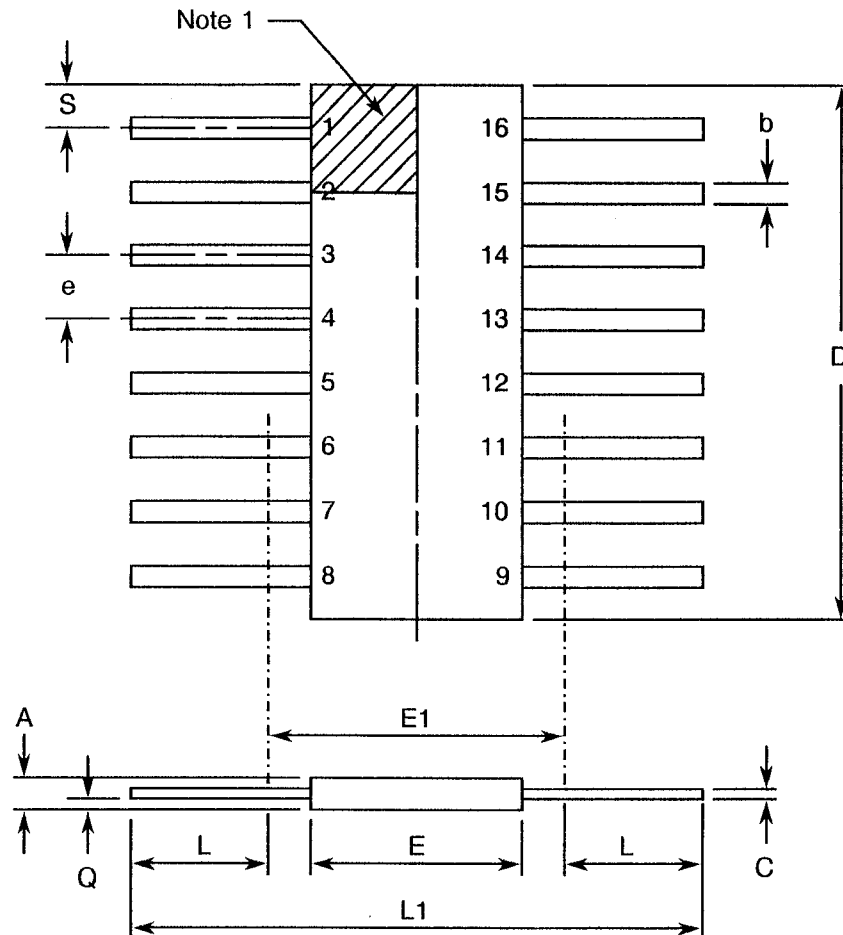

SYMBOL	MILLIMETRES		NOTES
	MIN	MAX	
A	1.27	2.03	
b	0.38	0.56	8
C	0.08	0.23	8
D	9.42	10.16	4
E	6.27	7.24	
E1	7.00 TYPICAL		4
e	1.27 TYPICAL		5, 9
L	7.87	8.89	8
L1	23.88	24.38	
Q	0.51	1.02	2
S	0.25	0.64	7

NOTES: See Page 11.

FIGURE 2 - PHYSICAL DIMENSIONS (CONTINUED)

FIGURE 2(b) - DUAL-IN-LINE PACKAGE

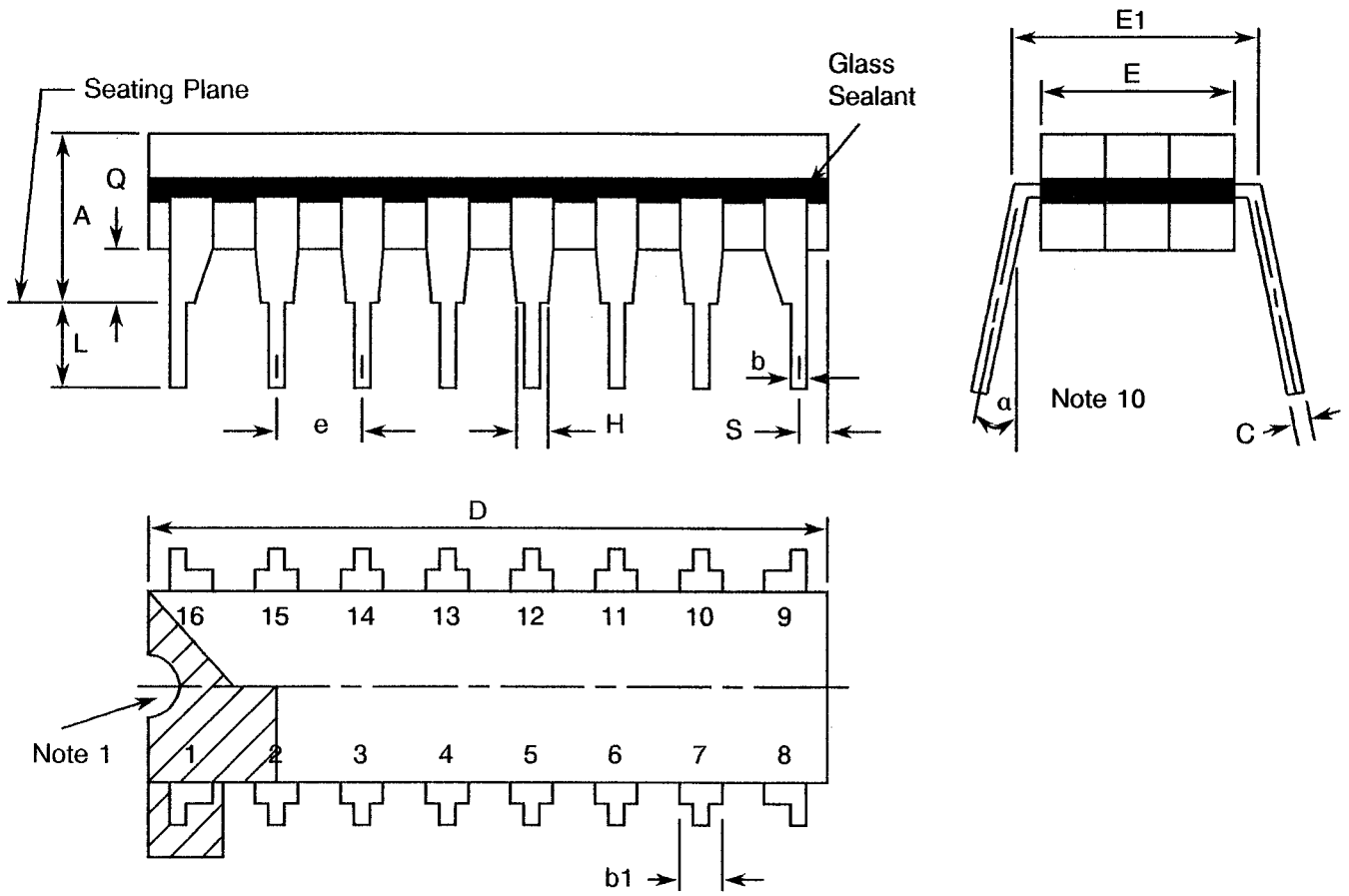

SYMBOL	MILLIMETRES		NOTES
	MIN	MAX	
A	-	5.08	
b	0.38	0.66	8
b1	-	1.78	8
C	0.20	0.44	8
D	19.18	19.94	4
E	6.22	7.62	4
E1	7.37	8.13	
e	2.54 TYPICAL		6, 9
F	1.27 TYPICAL		
H	0.76	-	
L	3.30	5.08	8
Q	0.51	-	3
S	0.38	1.27	7
a	0°	15°	10

NOTES: See Page 11.

FIGURE 2 - PHYSICAL DIMENSIONS (CONTINUED)

FIGURE 2(c) - DUAL-IN-LINE PACKAGE

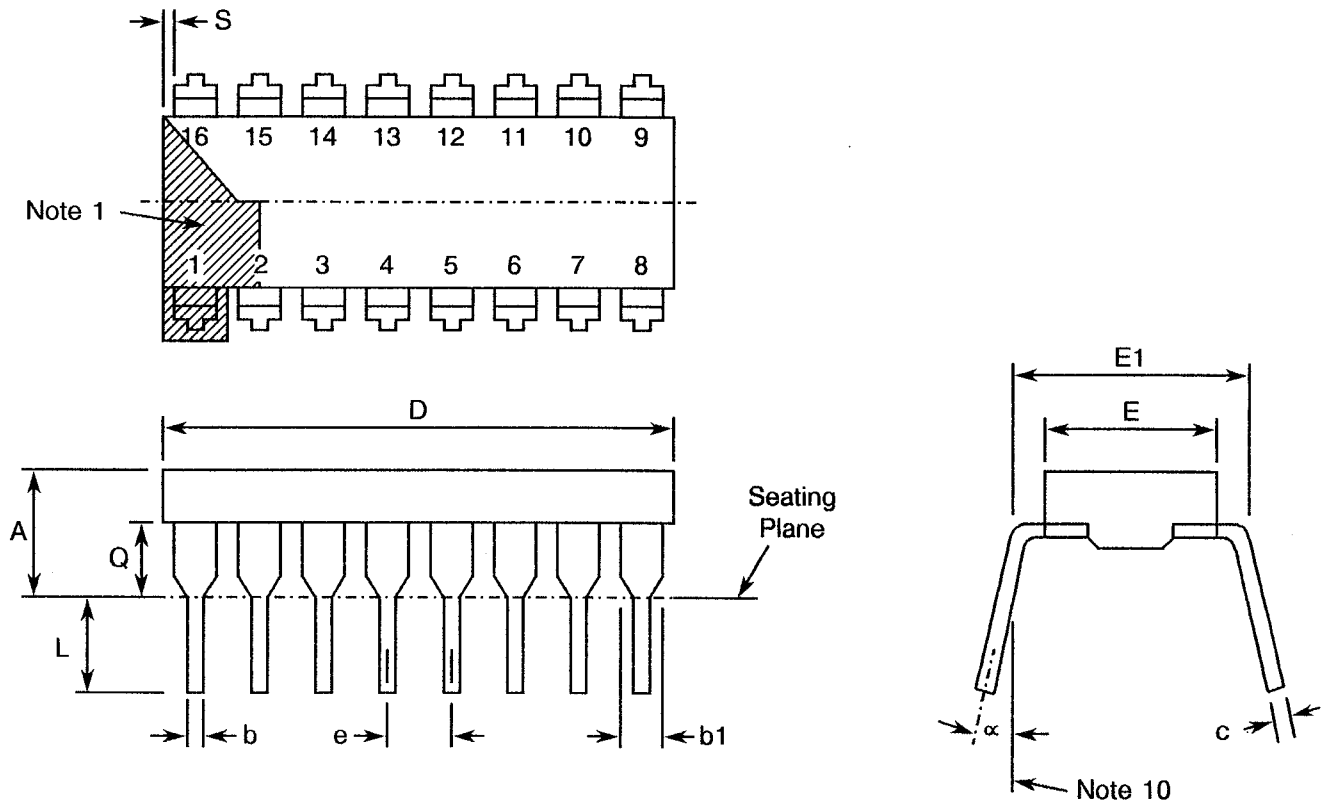

SYMBOL	MILLIMETRES		NOTES
	MIN.	MAX.	
A	-	5.08	-
b	0.36	0.58	8
b1	0.76	1.78	8
c	0.20	0.38	8
D	18.80	22.10	-
E	5.59	7.87	-
E1	7.37	8.13	4
e	2.54 TYPICAL		6, 9
L	3.18	5.08	-
Q	0.38	2.03	3
S	0.25	1.35	7
α	0°	15°	10

NOTES: See Page 11.

FIGURE 2 - PHYSICAL DIMENSIONS (CONTINUED)

FIGURE 2(d) - SQUARE CHIP CARRIER PACKAGE (3 LAYER BASE)

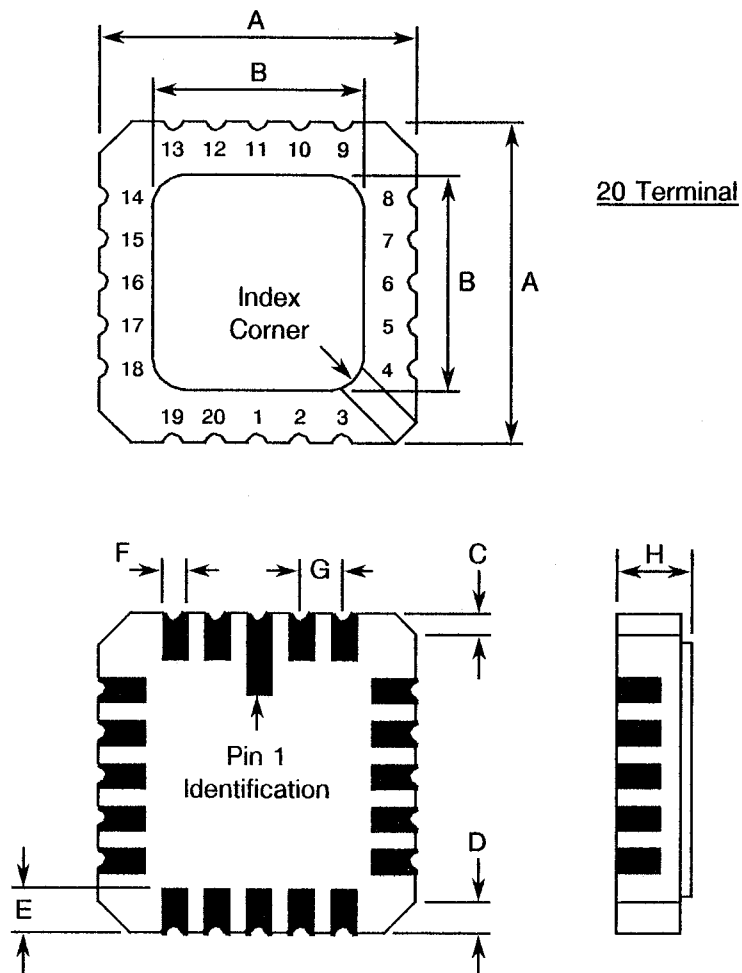

SYMBOL	MILLIMETRES		NOTES
	MIN.	MAX.	
A	8.687	9.093	-
B	7.798	9.093	-
C	0.250	0.510	11
D	0.889	1.143	12
E	1.140	1.400	8
F	0.559	0.712	8
G	1.27 TYPICAL		5, 9
H	1.630	2.540	-

NOTES: See Page 11.



		<p style="text-align: center;">ESA/SCC Detail Specification No. 9301/001</p>	<p>PAGE 11 ISSUE 4</p>
---	---	--	----------------------------

FIGURE 2 - PHYSICAL DIMENSIONS (CONTINUED)

NOTES TO FIGURES 2(a) TO 2(d)

1. Index area: a notch or a dot shall be located adjacent to Pin 1 and shall be within the shaded area shown. For chip carrier packages, the index shall be as shown in Figure 2(d).
2. Dimension Q shall be measured at the point of exit of the lead from the body.
3. Dimension Q shall be measured from the seating plane to the base plane.
4. This dimension allows for off-centre lids, meniscus and glass overrun.
5. The true position pin spacing is 1.27mm between centrelines. Each pin centreline shall be located within $\pm 0.13\text{mm}$ of its true longitudinal position relative to Pins 1 and 16.
6. The true position pin spacing is 2.54mm between centrelines. Each pin centreline shall be located within $\pm 0.25\text{mm}$ of its true longitudinal position relative to Pins 1 and 16.
7. Applies to all four corners.
8. All leads or terminals.
9. 14 spaces for flat and dual-in-line packages.
16 spaces for chip carrier packages.
10. Lead centre when α is 0° .
11. Index corner only - 2 dimensions.
12. 3 non-index corners - 6 dimensions.



FIGURE 3(a) - PIN ASSIGNMENT

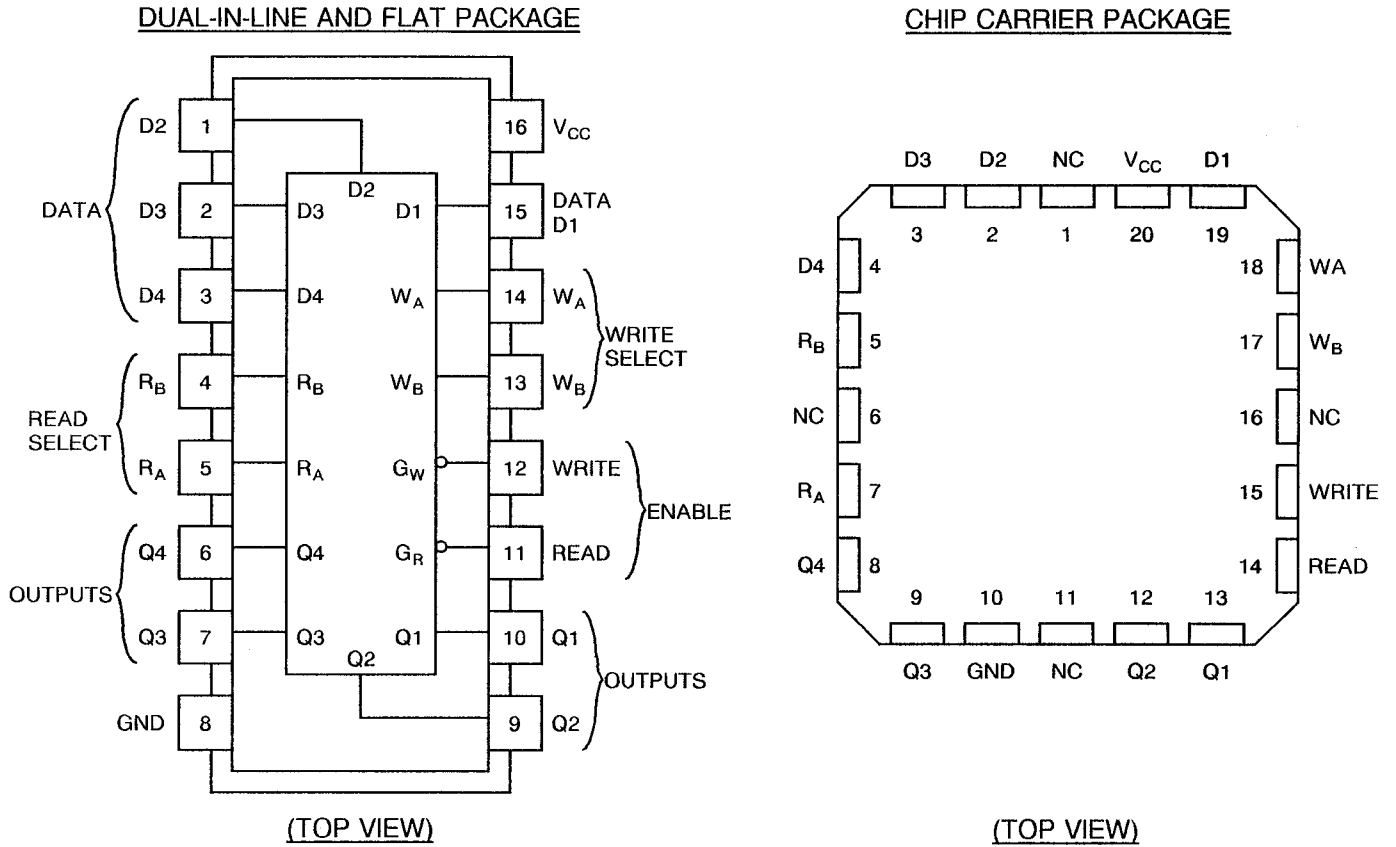

NOTES

1. Positive logic: see Figure 3(b).

FLAT PACKAGE AND DUAL-IN-LINE TO CHIP CARRIER PIN ASSIGNMENT

FLAT PACKAGE AND DUAL-IN-LINE PIN OUTS	1	2	3	4	5	6	7	8	9	10	11	12	13	14	15	16
CHIP CARRIER PIN OUTS	2	3	4	5	7	8	9	10	12	13	14	15	17	18	19	20

NOTES

1. All references throughout this specification relate to FLAT/DIL packages only.

FIGURE 3(b) - TRUTH TABLE

(EACH DECODER/DEMULTIPLEXER)

FUNCTION TABLE

WRITE FUNCTION TABLE

WRITE INPUTS			WORD			
W_B	W_A	G_W	0	1	2	3
L	L	L	Q=D	Q_0	Q_0	Q_0
L	H	L	Q_0	Q=D	Q_0	Q_0
H	L	L	Q_0	Q_0	Q=D	Q_0
H	H	L	Q_0	Q_0	Q_0	Q=D
X	X	H	Q_0	Q_0	Q_0	Q_0

READ FUNCTION TABLE

READ INPUTS			OUTPUTS			
R_B	R_A	G_W	Q1	Q2	Q3	Q4
L	L	L	W0B1	W0B2	W0B3	W0B4
L	H	L	W1B1	W1B2	W1B3	W1B4
H	L	L	W2B1	W2B2	W2B3	W2B4
H	H	L	W3B1	W3B2	W3B3	W3B4
X	X	H	Z	Z	Z	Z

NOTES

1. Logic Level Definitions: L = Low Level, H = High Level, X = Don't Care, Z = High Impedance (off).
2. (Q = D) = The four selected internal flip-flop outputs will assume the states applied to the four external data inputs.
3. Q_C = the level of Q before the indicated input conditions were established.
4. W0B1 = the first bit of word 0, etc.

FIGURE 3(c) - CIRCUIT SCHEMATIC

EQUIVALENT OF EACH INPUT

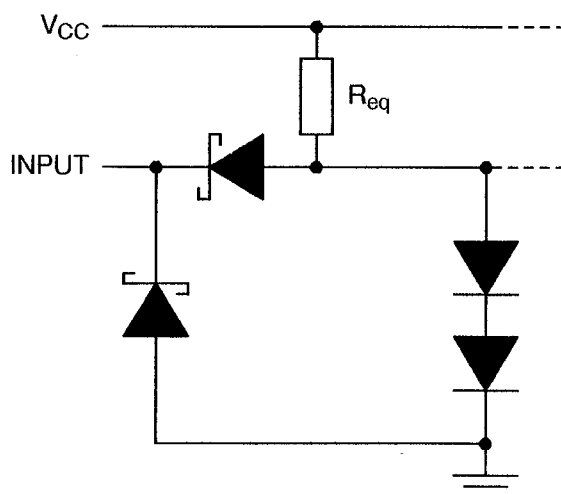

TYPICAL OF ALL OUTPUTS

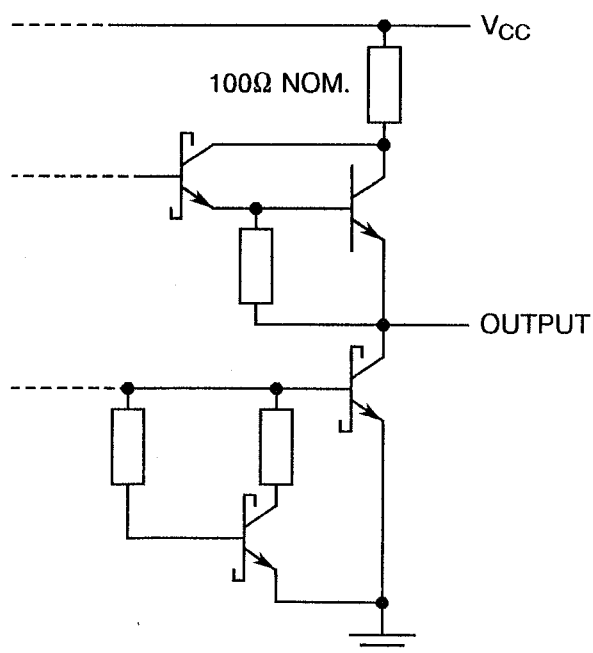



NOTES

1. Any D, R or W: $R_{eq} = 20k\Omega$ NOM.
 G_R : $R_{eq} = 6.67k\Omega$ NOM.
 G_W : $R_{eq} = 10k\Omega$ NOM.

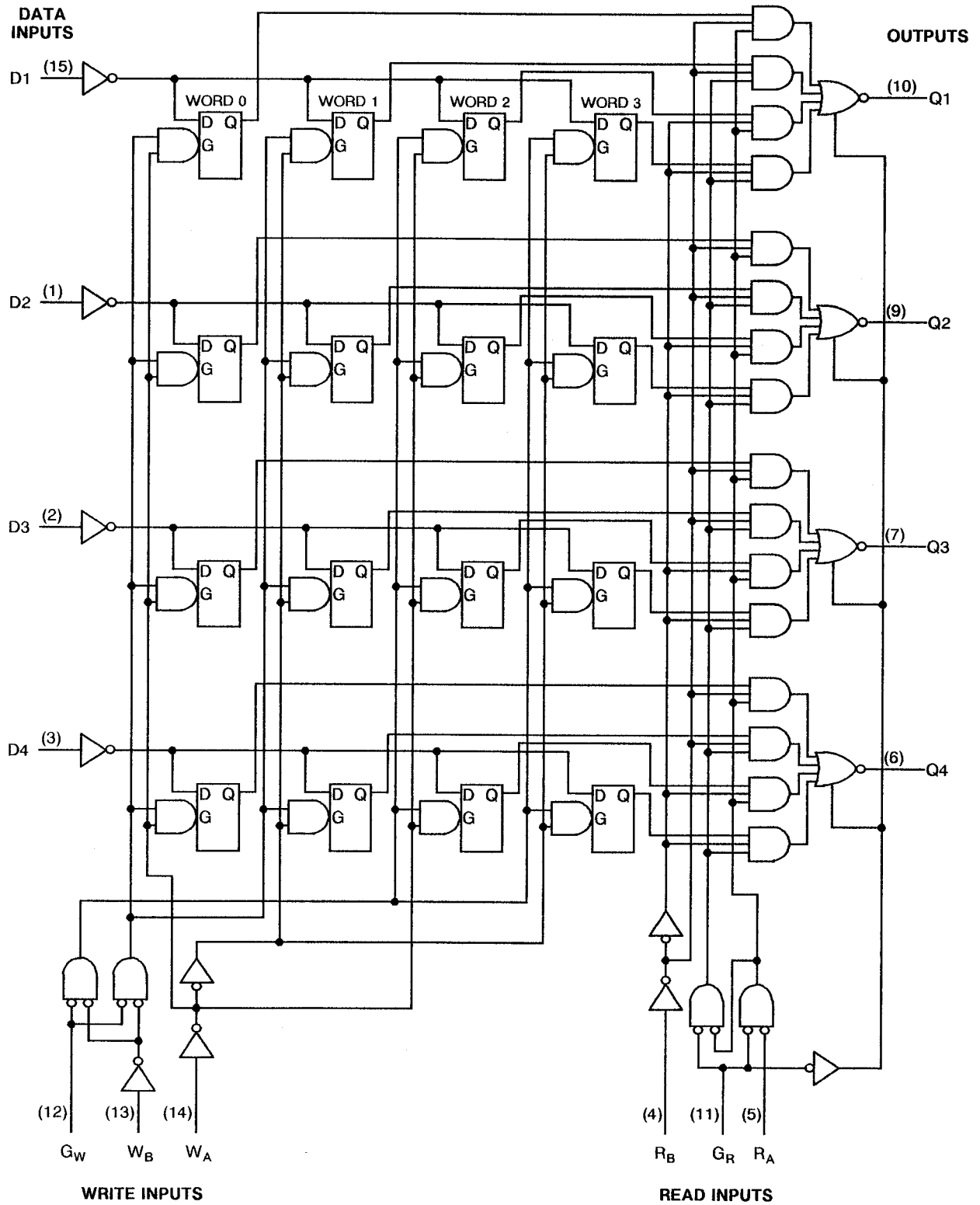

FIGURE 3(d) - FUNCTIONAL DIAGRAM



 	ESA/SCC Detail Specification No. 9301/001	PAGE 15 ISSUE 4
---	--	--------------------

2. APPLICABLE DOCUMENTS

The following documents form part of this specification and shall be read in conjunction with it:-

- (a) ESA/SCC Generic Specification No. 9000 for Integrated Circuits.
- (b) MIL-STD-883, Test Methods and Procedures for Micro-electronics.

3. TERMS, DEFINITIONS, ABBREVIATIONS, SYMBOLS AND UNITS

For the purpose of this specification, the terms, definitions, abbreviations, symbols and units specified in ESA/SCC Basic Specification No. 21300 shall apply. In addition, the following abbreviations are used:-

- V_{IC} = Input Clamp Voltage.
- I_{CC} = Supply Current.
- V_{CC} = Supply Voltage.

4. REQUIREMENTS

4.1 GENERAL

The complete requirements for procurement of the integrated circuits specified herein are stated in this specification and ESA/SCC Generic Specification No. 9000 for Integrated Circuits. Deviations from the Generic Specification applicable to this specification only, are listed in Para. 4.2.

Deviations from the applicable Generic Specification and this Detail Specification, formally agreed with specific Manufacturers on the basis that the alternative requirements are equivalent to the ESA/SCC requirements and do not affect the components' reliability, are listed in the appendices attached to this specification.

4.2 DEVIATIONS FROM GENERIC SPECIFICATION

4.2.1 Deviations from Special In-process Controls

None.

4.2.2 Deviations from Final Production Tests (Chart II)

None.

4.2.3 Deviations from Burn-in Tests (Chart III)

- (a) Para. 7.1.1(a), High Temperature Reverse Bias tests and subsequent electrical measurements related to this test shall be omitted.
- (b) Para. 9.9.2, Electrical Measurements at High and Low Temperatures: Only a test result summary, based on go-no-go tests and presented in histogram form is required.

4.2.4 Deviations from Qualification Tests (Chart IV)

None.

4.2.5 Deviations from Lot Acceptance Tests (Chart V)

None.

	<p style="text-align: center;">ESA/SCC Detail Specification No. 9301/001</p>	<p style="text-align: right;">PAGE 16 ISSUE 4</p>
---	--	---

4.3 MECHANICAL REQUIREMENTS

4.3.1 Dimension Check

The dimensions of the integrated circuits specified herein shall be checked. They shall conform to those shown in Figure 2.

4.3.2 Weight

The maximum weight of the integrated circuits specified herein shall be 0.7 grammes for the flat package, 2.2 grammes for the dual-in-line package and 0.6 grammes for the chip carrier package.

4.4 MATERIALS AND FINISHES

The materials and finishes shall be as specified herein. Where a definite material is not specified, a material which will enable the integrated circuits specified herein to meet the performance requirements of this specification shall be used. Acceptance or approval of any constituent material does not guarantee acceptance of the finished product.

4.4.1 Case

The case shall be hermetically sealed and have a metal body with hard glass seals or a ceramic body and the lids shall be welded, brazed, preform-soldered or glass frit-sealed.

4.4.2 Lead Material and Finish

For dual-in-line and flat packages, the material shall be either Type 'D' or Type 'G' with either Type '3 or 4', Type '4' or Type '7' finish in accordance with the requirements of ESA/SCC Basic Specification No. 23500. For chip carrier packages, the finish shall be either Type '4' or Type '7' in accordance with the requirements of ESA/SCC Basic Specification No. 23500. (See Table 1(a) for Type Variants).

4.5 MARKING

4.5.1 General

The marking of all components delivered to this specification shall be in accordance with the requirements of ESA/SCC Basic Specification No. 21700. Each component shall be marked in respect of:-

- (a) Lead Identification.
- (b) The SCC Component Number.
- (c) Traceability Information.

4.5.2 Lead Identification

For dual-in-line and flat packages, an index shall be located at the top of the package in the position defined in Note 1 to Figure 2 or, alternatively, a tab may be used to identify Pin No. 1. The pin numbering must be read with the index or tab on the left-hand side. For chip carrier packages, the index shall be as defined by Figure 2(d).

4.5.3 The SCC Component Number

Each component shall bear the SCC Component Number which shall be constituted and marked as follows:

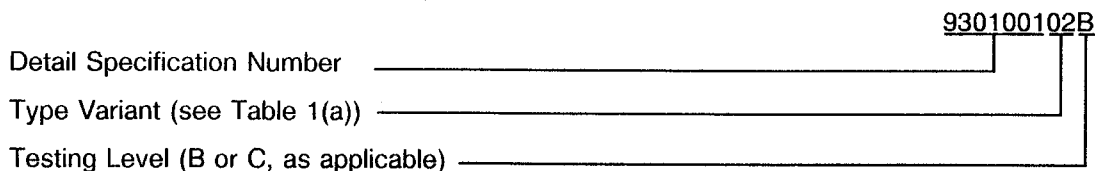

4.5.4 Traceability Information

Each component shall be marked in respect of traceability information in accordance with the requirements of ESA/SCC Basic Specification No. 21700.

4.6 ELECTRICAL MEASUREMENTS

4.6.1 Electrical Measurements at Room Temperature

The parameters to be measured in respect of electrical characteristics are scheduled in Table 2. Unless otherwise specified, the measurements shall be performed at $T_{amb} = +22 \pm 3$ °C.

4.6.2 Electrical Measurements at High and Low Temperatures

The parameters to be measured at high and low temperatures are scheduled in Table 3. The measurements shall be performed at $T_{amb} = +125$ and -55 °C respectively.

4.6.3 Circuits for Electrical Measurements

Circuits for use in performing the electrical measurements listed in Tables 2 and 3 of this specification are shown in Figure 4.

4.7 BURN-IN TESTS

4.7.1 Parameter Drift Values

The parameter drift values applicable to burn-in are specified in Table 4 of this specification. Unless otherwise stated, measurements shall be performed at $T_{amb} = +22 \pm 3$ °C. The parameter drift values (Δ) applicable to the parameters scheduled, shall not be exceeded. In addition to these drift value requirements, the appropriate limit value specified for a given parameter in Table 2 shall not be exceeded.

4.7.2 Conditions for Power Burn-in

The requirements for power burn-in are specified in Section 7 of ESA/SCC Generic Specification No. 9000. The conditions for power burn-in shall be as specified in Table 5 of this specification.

4.7.3 Electrical Circuits for Power Burn-in

Circuits for use in performing the power burn-in tests are shown in Figure 5 of this specification.

**TABLE 2 - ELECTRICAL MEASUREMENTS AT ROOM TEMPERATURE - D.C. PARAMETERS**

No.	CHARACTERISTICS	SYMBOL	TEST METHOD MIL-STD 883	TEST FIG.	TEST CONDITIONS (PINS UNDER TEST)	LIMITS		UNIT
						MIN	MAX	
1	Functional Test	-	-	3(b)	Verify Truth Table with Load. Note 1	-	-	-
2 to 9	Input Current High Level any D, R or W	I_{IH1}	3010	4(a)	$V_{CC} = 5.5V, V_{IN} = 2.7V$ (Pins 1-2-3-4-5-13-14-15)	-	20	μA
10 to 17	Input Current High Level any D, R or W (Max. Input Voltage)	I_{IH2}	3010	4(a)	$V_{CC} = 5.5V, V_{IN} = 7.0V$ (Pins 1-2-3-4-5-13-14-15)	-	100	μA
18	Input Current High Level G_W	I_{IH3}	3010	4(a)	$V_{CC} = 5.5V, V_{IN} = 2.7V$ (Pin 12)	-	40	μA
19	Input Current High Level G_W (Max. Input Voltage)	I_{IH4}	3010	4(a)	$V_{CC} = 5.5V, V_{IN} = 7.0V$ (Pin 12)	-	200	μA
20	Input Current High Level G_R	I_{IH5}	3010	4(a)	$V_{CC} = 5.5V, V_{IN} = 2.7V$ (Pin 11)	-	60	μA
21	Input Current High Level G_R (Max. Input Voltage)	I_{IH6}	3010	4(a)	$V_{CC} = 5.5V, V_{IN} = 7.0V$ (Pin 11)	-	300	μA
22 to 29	Input Clamp Voltage	V_{IC}	3009	4(b)	$V_{CC} = 4.5V, I_{IN} = -18mA$ Note 2 (Pins 1-2-3-4-5-11-12-13-14-15)	-	-1.5	V
30 to 37	Input Current Low Level any G_R or W	I_{IL1}	3009	4(c)	$V_{CC} = 5.5V, V_{IL} = 0.4V$ (Pins 1-2-3-4-5-13-14-15)	-	-0.4	mA
38	Input Current Low Level G_W	I_{IL2}	3009	4(c)	$V_{CC} = 5.5V, V_{IL} = 0.4V$ (Pin 12)	-	-0.8	mA
39	Input Current Low Level G_R	I_{IL3}	3009	4(c)	$V_{CC} = 5.5V, V_{IL} = 0.4V$ (Pin 11)	-	-1.2	mA
40 to 43	Output Voltage Low Level	V_{OL}	3007	4(d)	$V_{CC} = 4.5V, V_{IL} = 0.7V$ $V_{IH} = 2.0V, I_{OL} = 4.0mA$ (Pins 6-7-9-10)	-	0.4	V

NOTES: See Page 20.

**SEC**ESA/SCC Detail Specification
No. 9301/001

PAGE 19

ISSUE 4

TABLE 2 - ELECTRICAL MEASUREMENTS AT ROOM TEMPERATURE - D.C. PARAMETERS (CONT'D)

No.	CHARACTERISTICS	SYMBOL	TEST METHOD MIL-STD 883	TEST FIG.	TEST CONDITIONS (PINS UNDER TEST)	LIMITS		UNIT
						MIN	MAX	
44 to 47	Output Voltage High Level	V_{OH}	3006	4(e)	$V_{CC} = 4.5V$, $V_{IL} = 0.7V$ $V_{IH} = 2.0V$, $I_{OH} = -1.0mA$ (Pins 6-7-9-10)	2.4	-	V
48 to 51	Short Circuit Output Current	I_{OS}	3011	4(f)	$V_{CC} = 5.5V$ Note 3 (Pins 6-7-9-10)	- 15	- 100	mA
52	Supply Current	I_{CC}	3005	4(g)	$V_{CC} = 5.5V$ Note 4 (Pin 16)	-	50	mA
53 to 56	Output Current High Level Off-State	I_{OZH}	-	4(g)	$V_{CC} = 5.5V$, $V_{IH} = 2.0V$ $V_{OH} = 2.7V$ (Pins 6-7-9-10)	-	20	μA
57 to 60	Output Current Low Level Off-State	I_{OZL}	-	4(g)	$V_{CC} = 5.5V$, $V_{IH} = 2.0V$ $V_{OH} = 0.4V$ (Pins 6-7-9-10)	-	- 20	μA

NOTES: See Page 20.

TABLE 2 - ELECTRICAL MEASUREMENTS AT ROOM TEMPERATURE - A.C. PARAMETERS

No.	CHARACTERISTICS	SYMBOL	TEST METHOD MIL-STD 883	TEST FIG.	TEST CONDITIONS (PINS UNDER TEST) (NOTE 5)	LIMITS		UNIT
						MIN	MAX	
61 to 68	Low to High Level Read Select to any Output	t_{PLH}	3003	4(h)	$V_{CC} = 5.0V$ $R_L = 2.0k\Omega$ $C_L = 15pF$ (Pins 6-7-9-10)	-	40	ns
69 to 76	High to Low Level Read Select to any Output	t_{PHL}				-	45	
77 to 80	Low to High Level Write Enable to any Output	t_{PLH}				-	45	
81 to 84	High to Low Level Write Enable to any Output	t_{PHL}				-	50	
85 to 88	Low to High Level Data to any Output	t_{PLH}				-	45	
89 to 92	High to Low Level Data to any Output	t_{PHL}				-	40	
93 to 96	Output Enable Time to High Level	t_{PZH}	3003	4(h)	$V_{CC} = 5.0V$ $R_L = 2.0k\Omega$ $C_L = 5.0pF$ (Pins 6-7-9-10)	-	35	ns
97 to 100	Output Enable Time to Low Level	t_{PZL}				-	40	
101 to 104	Output Disable Time from High Level	t_{PHZ}				-	50	
105 to 108	Output Disable Time from Low Level	t_{PLZ}				-	35	

NOTES

1. Go-no-go test with $V_{IL} = 0.3V$; $V_{IH} = 3.0V$; trip point 1.5V.
2. All inputs and outputs not under test shall be open.
3. No more than one output should be shorted at a time, and only for 1 second maximum.
4. With all outputs open and 4.5V applied to all data and both enable inputs, I_{CC} is measured with address inputs grounded.
5. Propagation delay measurements shall be performed as a go-no-go test on a 100% basis. Read-and-record measurements shall be performed on an LTPD7 sample basis following the Chart III Burn-in Test.

**TABLE 3 - ELECTRICAL MEASUREMENTS AT HIGH AND LOW TEMPERATURES,
+ 125(+ 0 - 5) °C AND - 55(+ 5 - 0) °C**

No.	CHARACTERISTICS	SYMBOL	TEST METHOD MIL-STD 883	TEST FIG.	TEST CONDITIONS (PINS UNDER TEST)	LIMITS		UNIT
						MIN	MAX	
1	Functional Test	-	-	3(b)	Verify Truth Table with Load. Note 1	-	-	-
2 to 9	Input Current High Level any D, R or W	I _{IH1}	3010	4(a)	V _{CC} = 5.5V, V _{IN} = 2.7V (Pins 1-2-3-4-5-13-14-15)	-	20	μA
10 to 17	Input Current High Level any D, R or W (Max. Input Voltage)	I _{IH2}	3010	4(a)	V _{CC} = 5.5V, V _{IN} = 7.0V (Pins 1-2-3-4-5-13-14-15)	-	100	μA
18	Input Current High Level G _W	I _{IH3}	3010	4(a)	V _{CC} = 5.5V, V _{IN} = 2.7V (Pin 12)	-	40	μA
19	Input Current High Level G _W (Max. Input Voltage)	I _{IH4}	3010	4(a)	V _{CC} = 5.5V, V _{IN} = 7.0V (Pin 12)	-	200	μA
20	Input Current High Level G _R	I _{IH5}	3010	4(a)	V _{CC} = 5.5V, V _{IN} = 2.7V (Pin 11)	-	60	μA
21	Input Current High Level G _R (Max. Input Voltage)	I _{IH6}	3010	4(a)	V _{CC} = 5.5V, V _{IN} = 7.0V (Pin 11)	-	300	μA
22 to 29	Input Clamp Voltage	V _{IC}	3009	4(b)	V _{CC} = 4.5V, I _{IN} = - 18mA Note 2 (Pins 1-2-3-4-5-11-12-13-14-15)	-	- 1.5	V
30 to 37	Input Current Low Level any G _R or W	I _{IL1}	3009	4(c)	V _{CC} = 5.5V, V _{IL} = 0.4V (Pins 1-2-3-4-5-13-14-15)	-	- 0.4	mA
38	Input Current Low Level G _W	I _{IL2}	3009	4(c)	V _{CC} = 5.5V, V _{IL} = 0.4V (Pin 12)	-	- 0.8	mA
39	Input Current Low Level G _R	I _{IL3}	3009	4(c)	V _{CC} = 5.5V, V _{IL} = 0.4V (Pin 11)	-	- 1.2	mA
40 to 43	Output Voltage Low Level	V _{OL}	3007	4(d)	V _{CC} = 4.5V, V _{IL} = 0.7V V _{IH} = 2.0V, I _{OL} = 4.0mA (Pins 6-7-9-10)	-	0.4	V

NOTES: See Page 20.

**TABLE 3 - ELECTRICAL MEASUREMENTS AT HIGH AND LOW TEMPERATURES,
+ 125(+ 0 - 5) °C AND - 55(+ 5 - 0) °C (CONT'D)**

No.	CHARACTERISTICS	SYMBOL	TEST METHOD MIL-STD 883	TEST FIG.	TEST CONDITIONS (PINS UNDER TEST)	LIMITS		UNIT
						MIN	MAX	
44 to 47	Output Voltage High Level	V _{OH}	3006	4(e)	V _{CC} = 4.5V, V _{IL} = 0.7V V _{IH} = 2.0V, I _{OH} = - 1.0mA (Pins 6-7-9-10)	2.4	-	V
48 to 51	Short Circuit Output Current	I _{OS}	3011	4(f)	V _{CC} = 5.5V Note 3 (Pins 6-7-9-10)	- 15	- 100	mA
52	Supply Current	I _{CC}	3005	4(g)	V _{CC} = 5.5V Note 4 (Pin 16)	-	50	mA
53 to 56	Output Current High Level Off-State	I _{OZH}	-	4(g)	V _{CC} = 5.5V, V _{IH} = 2.0V V _{OH} = 2.7V (Pins 6-7-9-10)	-	20	μA
57 to 60	Output Current Low Level Off-State	I _{OZL}	-	4(g)	V _{CC} = 5.5V, V _{IH} = 2.0V V _{OH} = 0.4V (Pins 6-7-9-10)	-	- 20	μA

NOTES: See Page 20.

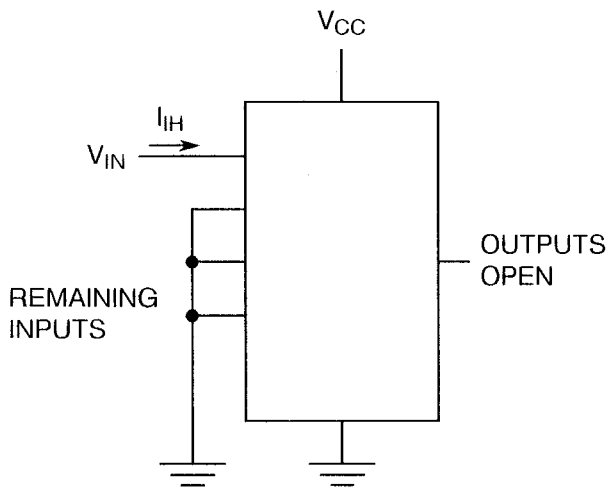
FIGURE 4 - CIRCUITS FOR ELECTRICAL MEASUREMENTS
FIGURE 4(a) - HIGH LEVEL INPUT CURRENT

NOTES

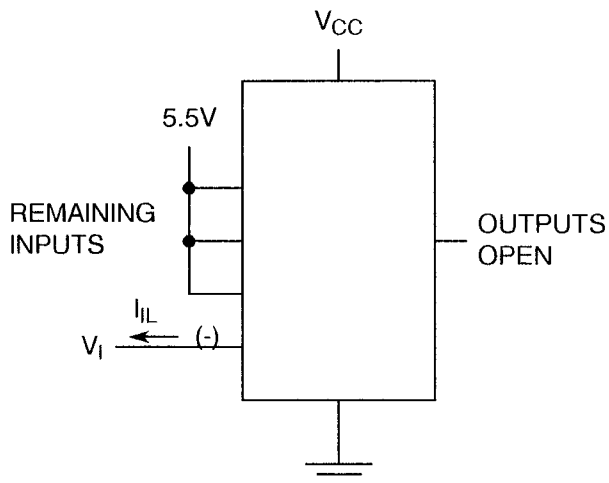
1. Test each input separately.

FIGURE 4(b) - INPUT CLAMP VOLTAGE

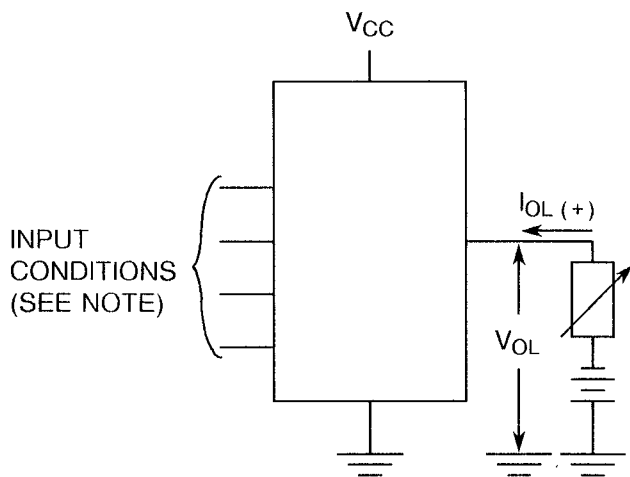
NOTES

1. Test each input separately.

FIGURE 4(c) - LOW LEVEL INPUT CURRENT

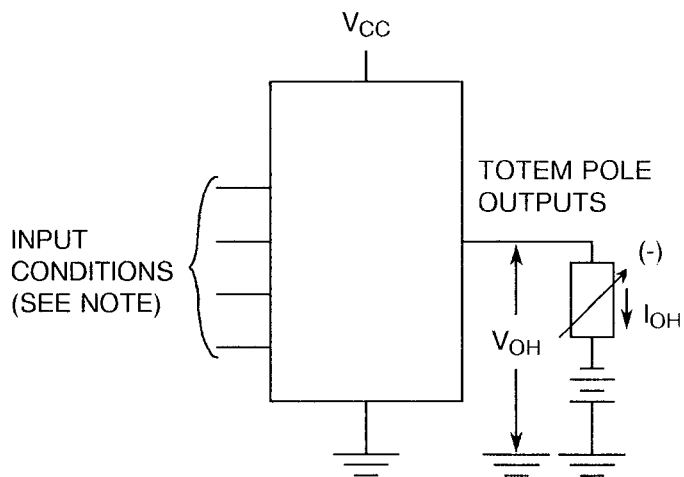
NOTES

1. Test each input separately.

FIGURE 4(d) - LOW LEVEL OUTPUT VOLTAGE

NOTES

1. Test per Truth Table.



FIGURE 4 - CIRCUITS FOR ELECTRICAL MEASUREMENTS (CONTINUED)

FIGURE 4(e) - HIGH LEVEL OUTPUT VOLTAGE

FIGURE 4(f) - SHORT CIRCUIT OUTPUT CURRENT

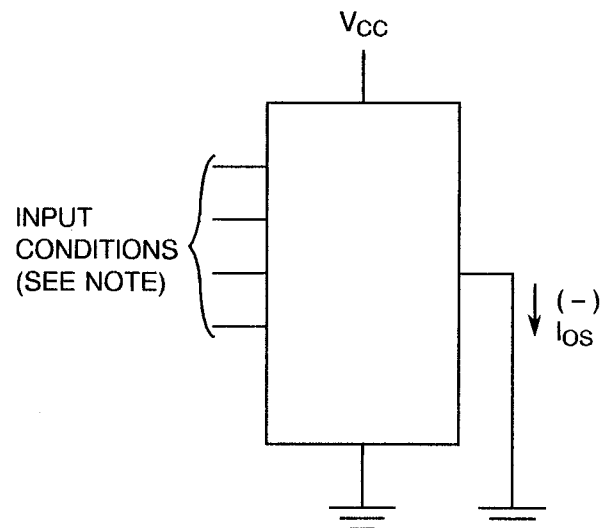
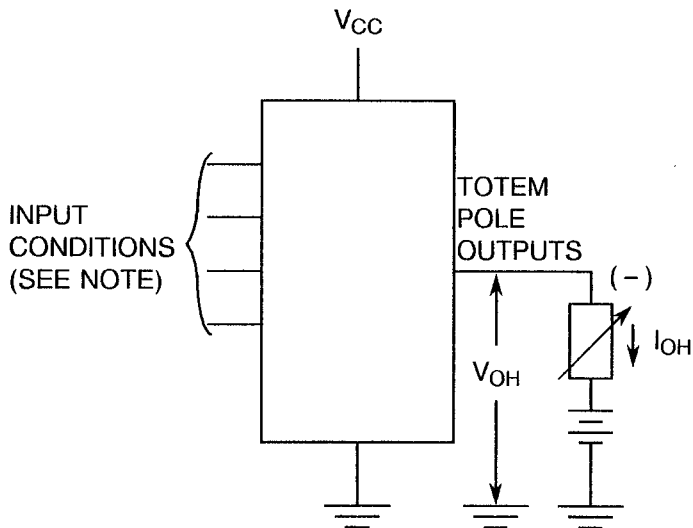

NOTES

1. Test per Truth Table.

NOTES

1. No more than one output should be shorted at a time.
2. Test per Truth Table.

FIGURE 4(g) - SUPPLY CURRENT

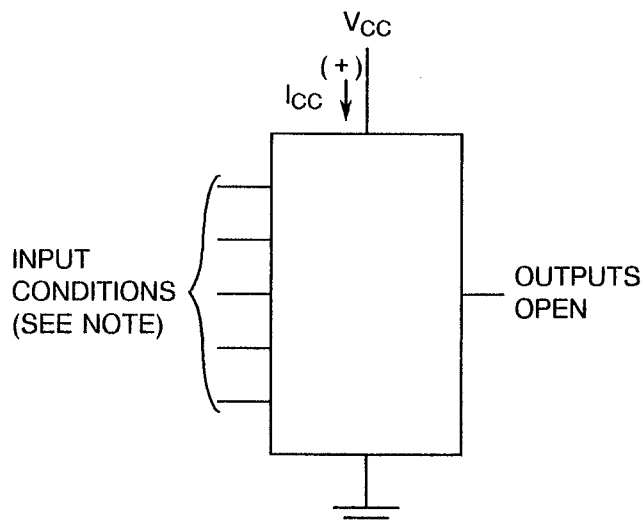

NOTES

1. See Note 4 to Table 2.

FIGURE 4 - CIRCUITS FOR ELECTRICAL MEASUREMENTS (CONTINUED)

FIGURE 4(h) - DYNAMIC TEST AND SWITCHING WAVEFORMS

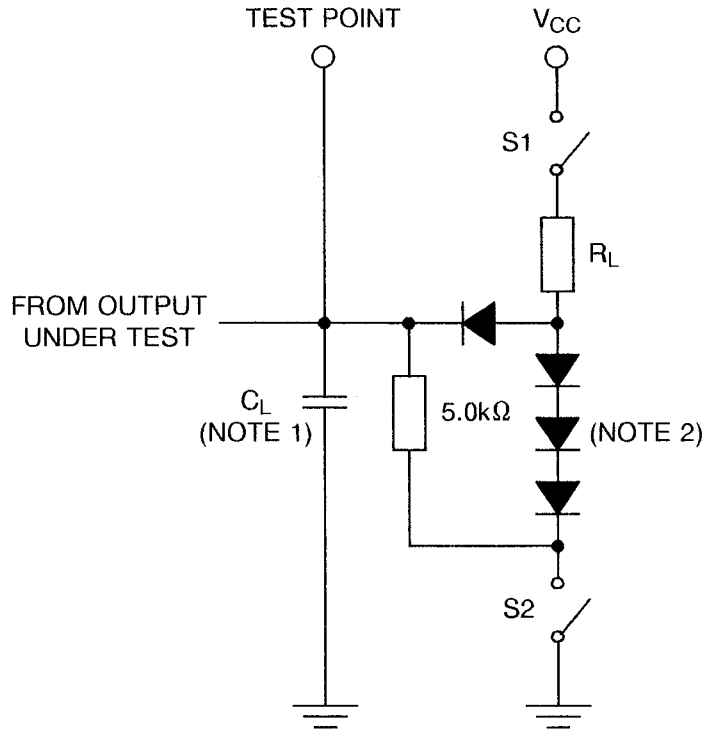

NOTES

1. C_L includes scope probe, wiring and stray capacitance without package in test fixture.
2. All diodes are 1N916 or 1N3064.

FIGURE 4 - CIRCUITS FOR ELECTRICAL MEASUREMENTS (CONTINUED)

FIGURE 4(h) - DYNAMIC TEST AND SWITCHING WAVEFORMS (CONTINUED)

VOLTAGE WAVEFORMS

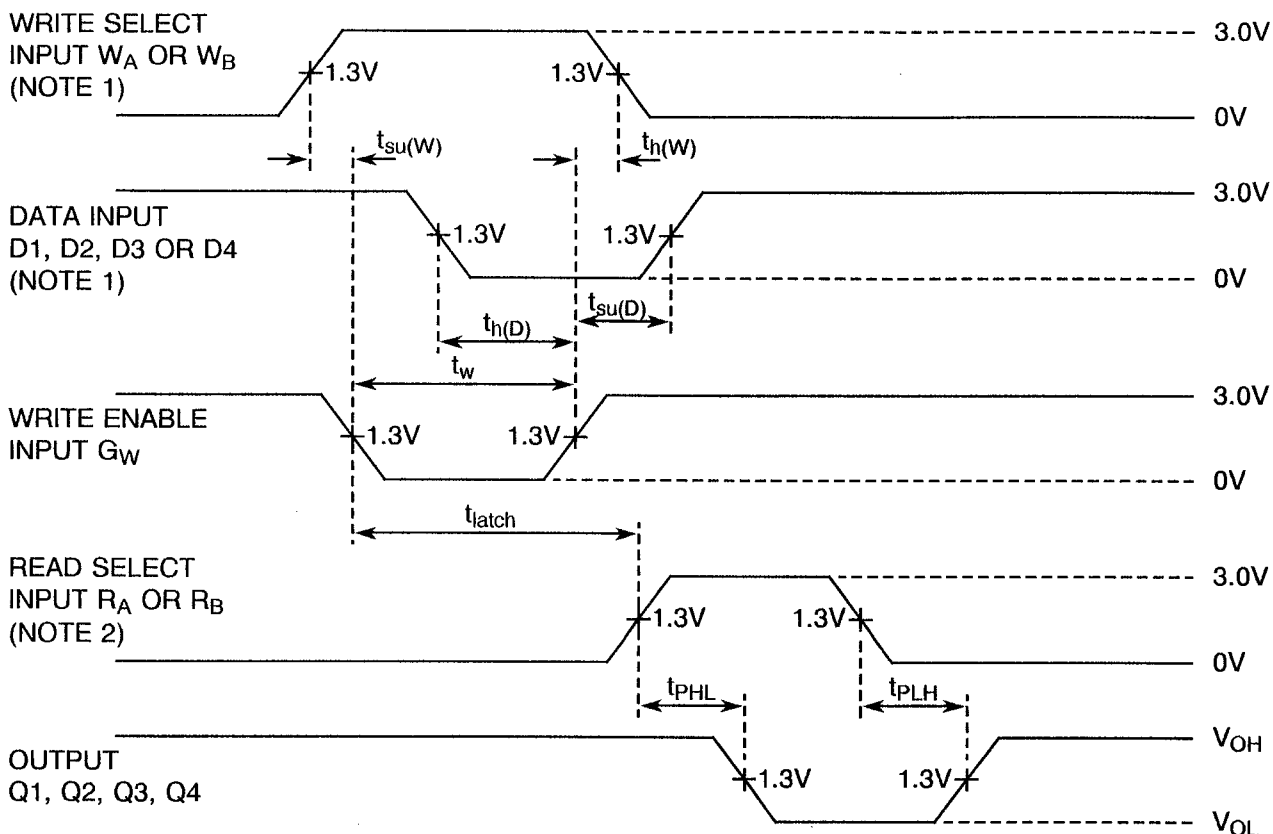

NOTES

1. High level input pulses at the select and data inputs are illustrated; times associated with low level pulses are measured from the same reference points.
2. When measuring delay times from a read select input, the read enable input is low.
3. Input waveforms are supplied by generators having the following characteristics: $t_r \leq 15ns$, $t_f \leq 6.0ns$, $PRR \leq 2.0MHz$, $Z_{OUT} = 50\Omega$, duty cycle $\leq 50\%$.



FIGURE 4 - CIRCUITS FOR ELECTRICAL MEASUREMENTS (CONTINUED)

FIGURE 4(h) - DYNAMIC TEST AND SWITCHING WAVEFORMS (CONTINUED)

VOLTAGE WAVEFORMS (CONTINUED)

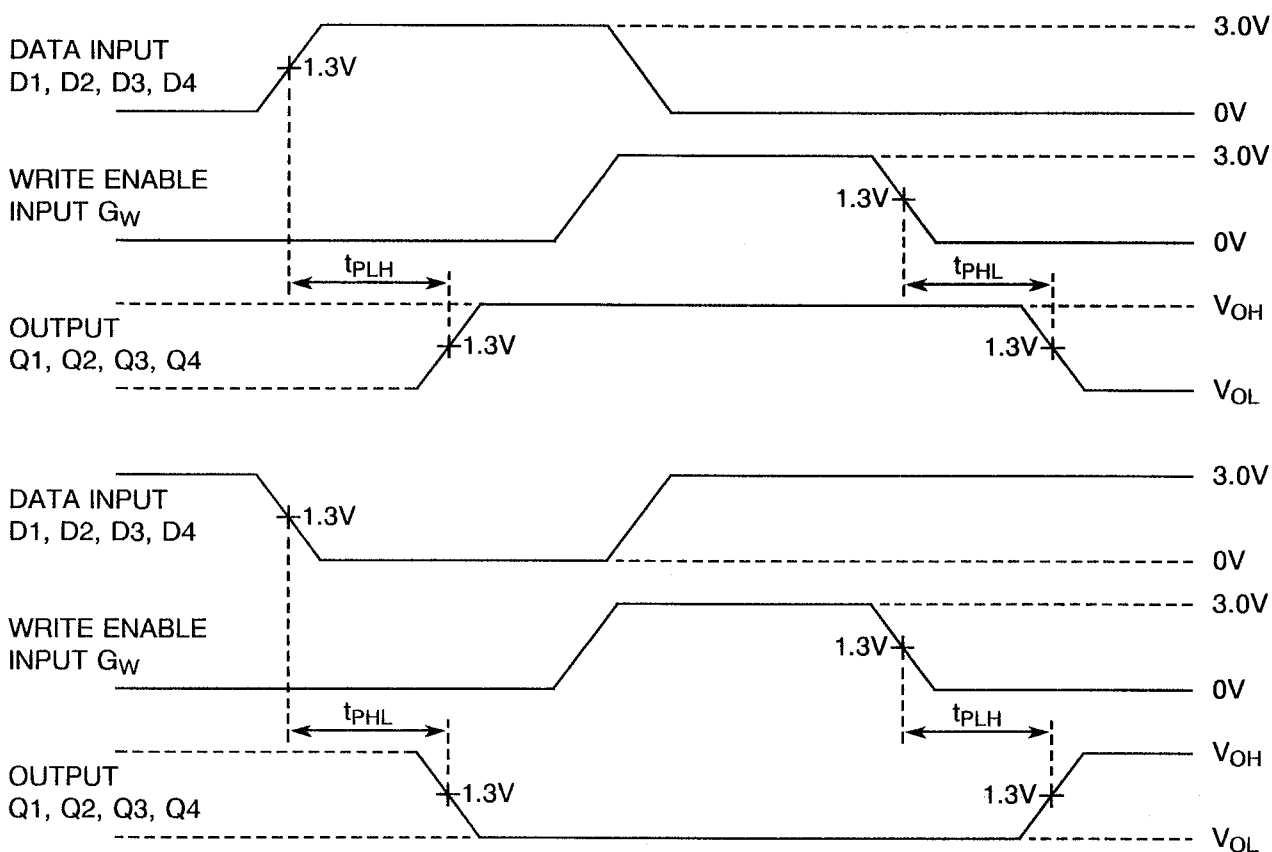

NOTES

1. Each select address is tested. Prior to the start of each of the above tests, both write and read address inputs are stabilised with $W_A = R_A$ and $W_B = R_B$. During the test, G_R is low.
2. Input waveforms are supplied by generators having the following characteristics: $t_r \leq 15ns$, $t_f \leq 6.0ns$, $PRR \leq 1.0MHz$, $Z_{OUT} = 50\Omega$, duty cycle $\leq 50\%$.



FIGURE 4 - CIRCUITS FOR ELECTRICAL MEASUREMENTS (CONTINUED)

FIGURE 4(h) - DYNAMIC TEST AND SWITCHING WAVEFORMS (CONTINUED)

VOLTAGE WAVEFORMS (CONTINUED)

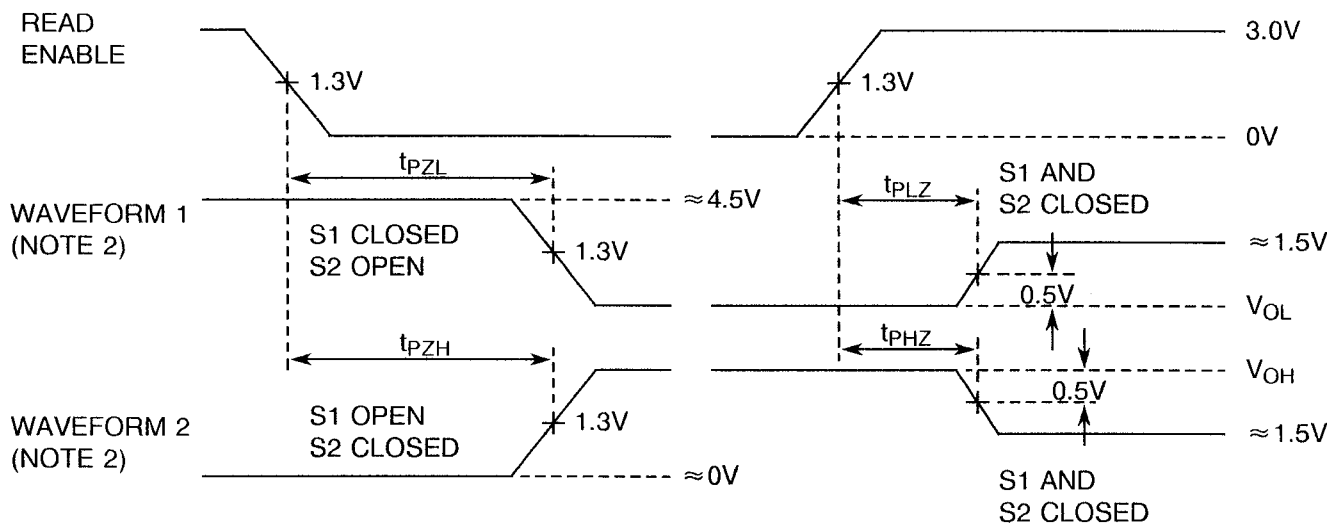

NOTES

1. Input waveforms are supplied by generators having the following characteristics: $t_r \leq 15\text{ns}$, $t_f \leq 6.0\text{ns}$, $\text{PRR} \leq 1.0\text{MHz}$, $Z_{OUT} = 50\Omega$, duty cycle $\leq 50\%$.
2. Waveform 1 is for an output with internal conditions such that the output is low except when disabled by the read enable input.
Waveform 2 is for an output with internal conditions such that the output is high except when disabled by the read enable input.
3. When measuring delay times from the read enable input, both read select inputs have been established at steady state.

**TABLE 4 - PARAMETER DRIFT VALUES**

No.	CHARACTERISTICS	SYMBOL	SPEC. AND/OR TEST METHOD	TEST CONDITIONS	CHANGE LIMITS (Δ)	UNIT
2 to 9	Input Current High Level 1	I_{IH1}	As per Table 2	As per Table 2	± 20 or (1) ± 0.5	% μA
30 to 37	Input Current Low Level	I_{IL1}	As per Table 2	As per Table 2	± 18	μA
40 to 43	Output Voltage Low Level	V_{OL}	As per Table 2	As per Table 2	± 60	mV
44 to 47	Output Voltage High Level	V_{OH}	As per Table 2	As per Table 2	± 240	mV

NOTES

1. Whichever is greater, referred to the initial value.

TABLE 5 - CONDITIONS FOR POWER BURN-IN AND OPERATING LIFE TEST

No.	CHARACTERISTICS	SYMBOL	CONDITION	UNIT
1	Ambient Temperature	T_{amb}	+ 125(+ 0 - 5)	$^{\circ}C$
2	Power Supply Voltage	V_{CC}	5(+ 0.5 - 0)	V
3	Pulse Voltage	V_{GEN}	0.5 max. to 3.0 min.	V
4	Frequency	f	100 (Note 1)	Hz
5	Fan-out	-	10	-
6	Rise Time	t_r	50 max.	μs
7	Fall Time	t_f	50 max.	μs
8	Duty Cycle	-	20 min.	%

NOTES

1. Tolerance $\pm 10\%$.



FIGURE 5 - ELECTRICAL CIRCUIT FOR POWER BURN-IN AND OPERATING LIFE TEST

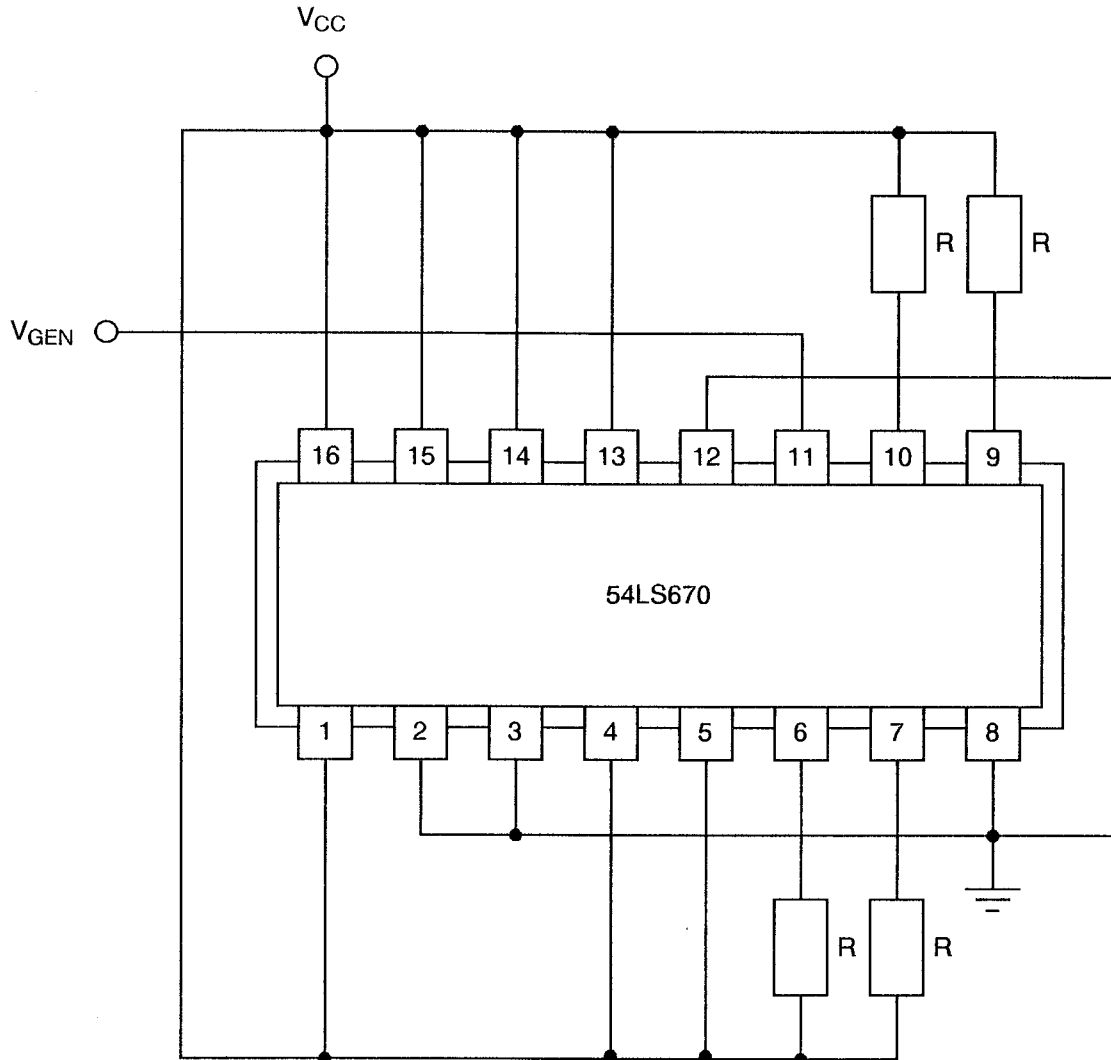

NOTES

- 1. R = 1.2k Ω .



4.8 ENVIRONMENTAL AND ENDURANCE TESTS (CHARTS IV AND V OF ESA/SCC GENERIC SPECIFICATION NO. 9000)

4.8.1 Electrical Measurements on Completion of Environmental Tests

The parameters to be measured on completion of environmental tests are scheduled in Table 6. Unless otherwise stated, the measurements shall be performed at $T_{amb} = +22 \pm 3$ °C.

4.8.2 Electrical Measurements at Intermediate Points during Endurance Tests

The parameters to be measured at intermediate points during endurance tests are as scheduled in Table 6 of this specification.

4.8.3 Electrical Measurements on Completion of Endurance Tests

The parameters to be measured on completion of endurance testing are as scheduled in Table 6 of this specification. Unless otherwise stated, the measurements shall be performed at $T_{amb} = +22 \pm 3$ °C.

4.8.4 Conditions for Operating Life Tests

The requirements for operating life testing are specified in Section 9 of ESA/SCC Generic Specification No. 9000. The conditions for operating life testing shall be as specified in Table 5 of this specification.

4.8.5 Electrical Circuits for Operating Life Tests

Circuits for use in performing the operating life tests are shown in Figure 5.

4.8.6 Conditions for High Temperature Storage Test

The requirements for the high temperature storage test are specified in ESA/SCC Generic Specification No. 9000. The conditions for high temperature storage shall be $T_{amb} = +150(+0-5)$ °C.

**TABLE 6 - ELECTRICAL MEASUREMENTS ON COMPLETION OF ENVIRONMENTAL TESTS AND AT INTERMEDIATE POINTS AND ON COMPLETION OF ENDURANCE TESTS**

No.	CHARACTERISTICS	SYMBOL	SPEC. AND/OR TEST METHOD	TEST CONDITIONS	CHANGE LIMITS		UNIT
					(Δ)	ABSOLUTE	
2 to 9	Input Current High Level 1	I_{IH1}	As per Table 2	As per Table 2	± 1.0	-	μA
10 to 17	Input Current High Level 2	I_{IH2}	As per Table 2	As per Table 2	-	100	μA
30 to 37	Input Current Low Level	I_{IL}	As per Table 2	As per Table 2	± 12	-	μA
40 to 43	Output Voltage Low Level	V_{OL}	As per Table 2	As per Table 2	± 60	-	mV
44 to 47	Output Voltage High Level	V_{OH}	As per Table 2	As per Table 2	± 240	-	mV
52	Supply Current	I_{CCH}	As per Table 2	As per Table 2	± 20	-	%

	<p>ESA/SCC Detail Specification No. 9301/001</p>	<p>PAGE 33 ISSUE 4</p>
---	--	----------------------------

APPENDIX 'A'

Page 1 of 1

AGREED DEVIATIONS FOR TEXAS INSTRUMENTS (F)

ITEMS AFFECTED	DESCRIPTION OF DEVIATIONS
Para. 4.2.1	Scanning Electron Microscope (SEM) Inspection may be performed using TIF document TIF 3.61.610.001.
Para. 4.2.2	Prior to Die Shear Test TIF may perform a Radiographic Inspection on the randomly chosen samples to be subjected to this test, using TIF document TIF 50.42-3002.
Para. 4.2.3	Radiographic Inspection may be performed using TIF document TIF 50.42-3002.