



**RF CABLE ASSEMBLY, SMA, 50 OHMS,
2.2mm FLEXIBLE CABLE, DC TO 22GHz**

BASED ON TYPE 8S-SMA

ESCC Detail Specification No. 3408/002

Issue 2	June 2021
---------	-----------



LEGAL DISCLAIMER AND COPYRIGHT

European Space Agency, Copyright © 2021, All rights reserved.

The European Space Agency disclaims any liability or responsibility, to any person or entity, with respect to any loss or damage caused, or alleged to be caused, directly or indirectly by the use and application of this ESCC publication.

This publication, without the prior permission of the European Space Agency and provided that it is not used for a commercial purpose, may be:

- copied in whole, in any medium, without alteration or modification.
- copied in part, in any medium, provided that the ESCC document identification, comprising the ESCC symbol, document number and document issue, is removed.

DOCUMENTATION CHANGE NOTICE

(Refer to <https://escies.org> for ESCC DCR content)

DCR No.	CHANGE DESCRIPTION
1427	Specification updated to incorporate changes per DCR.

TABLE OF CONTENTS

1	GENERAL	5
1.1	SCOPE	5
1.2	APPLICABLE DOCUMENTS	5
1.3	TERMS, DEFINITIONS, ABBREVIATIONS, SYMBOLS AND UNITS	5
1.4	THE ESCC COMPONENT NUMBER AND COMPONENT TYPE VARIANTS	5
1.4.1	The ESCC Component Number	5
1.4.1.1	Characteristics Codes	5
1.4.2	Component Type Variants and Range of Components	6
1.5	MAXIMUM RATINGS	7
1.6	PHYSICAL DIMENSIONS	8
1.6.1	Cable Assembly	8
1.6.2	Connectors	8
1.6.2.1	SMA, Male, Straight Plug	8
1.6.2.2	SMA, Male, 90° Clip Plug	9
1.6.2.3	SMA, Male, 90° Box Plug	9
1.6.2.4	SMA, Female, Straight Jack	10
1.6.2.5	SMA, Female, Bulkhead Jack	10
1.6.3	Connector Interface Dimensions and Connector Interface Gauge Dimensions	11
1.7	ADD-ON COMPONENTS	11
1.7.1	Connectors	11
1.7.2	Cable	11
1.8	MATERIALS AND FINISHES	11
1.8.1	Connectors	11
1.8.2	Cable	11
2	REQUIREMENTS	12
2.1	GENERAL	12
2.1.1	Deviations from the Generic Specification	12
2.1.1.1	Deviations from Production Control – Chart F2	12
2.2	MARKING	12
2.3	ENVIRONMENTAL AND MECHANICAL TESTS	13
2.4	ROOM TEMPERATURE ELECTRICAL MEASUREMENTS	14
2.5	INTERMEDIATE AND END-POINT ELECTRICAL MEASUREMENTS	15
APPENDIX A		17

1 GENERAL

1.1 SCOPE

This specification details the ratings, physical and electrical characteristics and test and inspection data for the component type variants and/or the range of components specified below. It supplements the requirements of, and shall be read in conjunction with, the ESCC Generic Specification listed under Applicable Documents.

1.2 APPLICABLE DOCUMENTS

The following documents form part of this specification and shall be read in conjunction with it:

- (a) ESCC Generic Specification No. [3408](#).
- (b) [MIL-STD-348](#), Department of Defence Interface Standard: Radio Frequency Connector Interfaces.

1.3 TERMS, DEFINITIONS, ABBREVIATIONS, SYMBOLS AND UNITS

For the purpose of this specification, the terms, definitions, abbreviations, symbols and units specified in ESCC Basic Specification No. [21300](#) shall apply.

1.4 THE ESCC COMPONENT NUMBER AND COMPONENT TYPE VARIANTS

1.4.1 The ESCC Component Number

The ESCC Component Number shall be constituted as follows:

Example: 34080020100600

- Detail Specification Reference: 3408002
- Component Type Variant Number: 01 (as required)
- Characteristic code: Total Length (600mm): 00600 (as required)

1.4.1.1 *Characteristics Codes*

Characteristics to be codified as part of the ESCC Component Number shall be as follows:

- (a) The total nominal length of the cable assembly, L, expressed by means of the following codes. The unit quantity shall be millimetre (mm).

Nominal Length L (mm) (Note 1)	Code
XXX	00XXX
XXXX	0XXXX
XXXXX	XXXXX

NOTES:

1. See Paras. 1.4.2 and 1.6.1.

1.4.2 Component Type Variants and Range of Components

The component type variants and range of components applicable to this specification are as follows:

Variant Number	Connector 1 Type (See Paras. 1.6.1 & 1.7.1)	Connector 2 Type (See Paras. 1.6.1 & 1.7.1)	Cable Type (See Para. 1.7.2)	Total Length L (mm) (Note 1) (See Para. 1.6.1)	Weight Max (g)
01	SMA, Male, Straight Plug	SMA, Male, Straight Plug	RF ePTFE Flexible Cable Ø2.2mm	80 to 50000	Note 2
02	SMA, Male, Straight Plug	SMA, Male, 90° Clip Plug	RF ePTFE Flexible Cable Ø2.2mm	80 to 50000	Note 2
03	SMA, Male, Straight Plug	SMA, Male, 90° Box Plug	RF ePTFE Flexible Cable Ø2.2mm	80 to 50000	Note 2
05	SMA, Male, Straight Plug	SMA, Female, Straight Jack	RF ePTFE Flexible Cable Ø2.2mm	80 to 50000	Note 2
06	SMA, Male, Straight Plug	SMA, Female, Bulkhead Jack	RF ePTFE Flexible Cable Ø2.2mm	80 to 50000	Note 2
07	SMA, Male, 90° Clip Plug	SMA, Male, 90° Clip Plug	RF ePTFE Flexible Cable Ø2.2mm	80 to 50000	Note 2
08	SMA, Male, 90° Clip Plug	SMA, Male, 90° Box Plug	RF ePTFE Flexible Cable Ø2.2mm	80 to 50000	Note 2
10	SMA, Male, 90° Clip Plug	SMA, Female, Straight Jack	RF ePTFE Flexible Cable Ø2.2mm	80 to 50000	Note 2
11	SMA, Male, 90° Clip Plug	SMA, Female, Bulkhead Jack	RF ePTFE Flexible Cable Ø2.2mm	80 to 50000	Note 2
12	SMA, Male, 90° Box Plug	SMA, Male, 90° Box Plug	RF ePTFE Flexible Cable Ø2.2mm	80 to 50000	Note 2
14	SMA, Male, 90° Box Plug	SMA, Female, Straight Jack	RF ePTFE Flexible Cable Ø2.2mm	80 to 50000	Note 2
15	SMA, Male, 90° Box Plug	SMA, Female, Bulkhead Jack	RF ePTFE Flexible Cable Ø2.2mm	80 to 50000	Note 2
19	SMA, Female, Straight Jack	SMA, Female, Straight Jack	RF ePTFE Flexible Cable Ø2.2mm	80 to 50000	Note 2
20	SMA, Female, Straight Jack	SMA, Female, Bulkhead Jack	RF ePTFE Flexible Cable Ø2.2mm	80 to 50000	Note 2
21	SMA, Female, Bulkhead Jack	SMA, Female, Bulkhead Jack	RF ePTFE Flexible Cable Ø2.2mm	80 to 50000	Note 2

NOTES:

1. Any length in the given range is available.
2. The cable assembly total maximum weight may be calculated from the connector weights and the cable weight as follows:
 - each connector:
 - SMA, Male, Straight Plug: 3g maximum
 - SMA, Male, 90° Clip Plug: 5g maximum
 - SMA, Male, 90° Box Plug: 4g maximum
 - SMA, Female, Straight Jack: 3g maximum
 - SMA, Female, Bulkhead Jack: 4g maximum
 - cable (all Variants): 13.1g/m maximum.

1.5 MAXIMUM RATINGS

The maximum ratings shall not be exceeded at any time during use or storage.

Maximum ratings shall only be exceeded during testing to the extent specified in this specification and when stipulated in Test Methods and Procedures of the ESCC Generic Specification.

Characteristics	Symbols	Maximum Ratings	Units	Remarks
RF Power (continuous)	P_{rf}	1	W	Without corona breakdown, Notes 1, 2
Nominal Impedance	Z	50	Ω	
Operating Frequency Range	f_{op}	DC to 22	GHz	
Minimum Bending Radius	R_{min}	12.7	mm	
Operating Temperature Range	T_{op}	-55 to +150	$^{\circ}C$	T_{amb}
Storage Temperature Range	T_{stg}	-55 to +150	$^{\circ}C$	
Coupling Nut Torque	T_q	170	N.cm	Coupling Proof Torque Note 3

NOTES:

1. At $T_{amb} = +40^{\circ}C$. For $T_{amb} > +40^{\circ}C$, derate power linearly to 55% at $T_{amb} = +150^{\circ}C$.
2. At ambient environmental pressure (101kPa). For pressure less than ambient, derate power linearly to 30% when in vacuum ($\leq 133Pa$).
3. Whenever a test is performed on mated pairs of connectors, the pairs shall be torqued at 80 to 110N.cm.

1.6 PHYSICAL DIMENSIONS

1.6.1 Cable Assembly

EXAMPLE: VARIANT 03

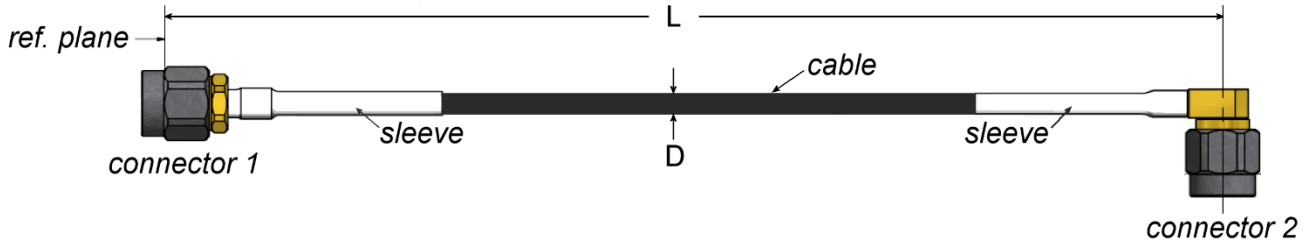

Symbols	Dimensions mm		Remarks
	Min	Max	
L	L - 5	L + 5	For L (nominal length) = 80 to 1500mm; see Para. 1.4.2
	L - 12	L + 12	For L (nominal length) = 1501 to 4600mm; see Para. 1.4.2
	L - 24	L + 24	For L (nominal length) = 4601 to 7600mm; see Para. 1.4.2
	L - 30	L + 30	For L (nominal length) = 7601 to 10000mm; see Para. 1.4.2
	L - 50	L + 50	For L (nominal length) = 10001 to 50000mm; see Para. 1.4.2
ØD	2.15	2.25	Cable outer diameter

NOTES:

- For connector dimensions, see Para. 1.6.2 (as applicable) and Para. 1.6.3.

1.6.2 Connectors

1.6.2.1 SMA, Male, Straight Plug

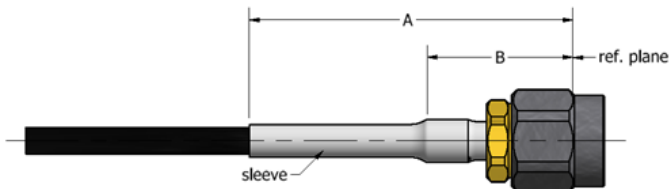

Symbols	Dimensions mm	
	Min	Max
A	17	30
B	12.2	12.6

NOTES:

- For connector interface dimensions, see Para. 1.6.3.

1.6.2.2 SMA, Male, 90° Clip Plug

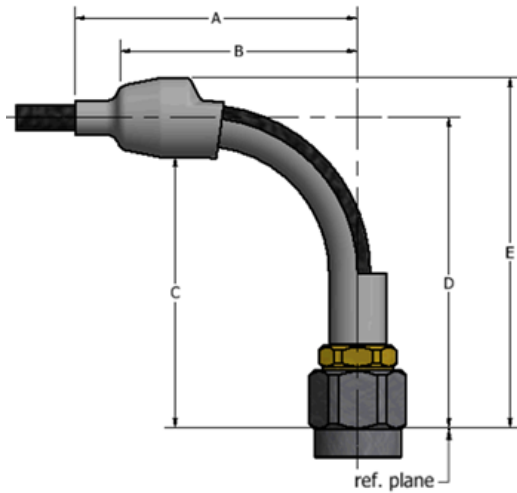

Symbols	Dimensions mm	
	Min	Max
A	21	36
B	-	17
C	23.5	-
D	26.7 BSC	
E	-	30.5

NOTES:

1. For connector interface dimensions, see Para. 1.6.3.

1.6.2.3 SMA, Male, 90° Box Plug

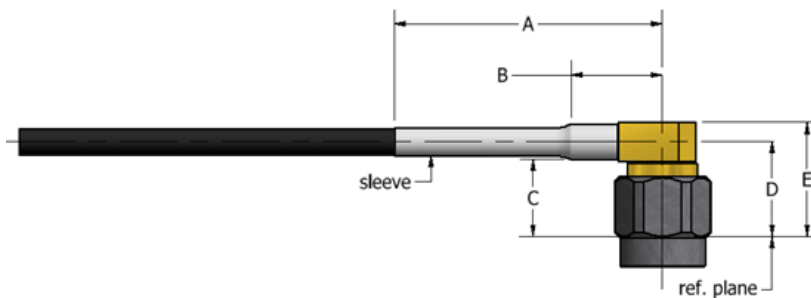

Symbols	Dimensions mm	
	Min	Max
A	14	27
B	8	8.4
C	6.6	-
D	8.2 BSC	
E	-	10

NOTES:

1. For connector interface dimensions, see Para. 1.6.3.

1.6.2.4 SMA, Female, Straight Jack

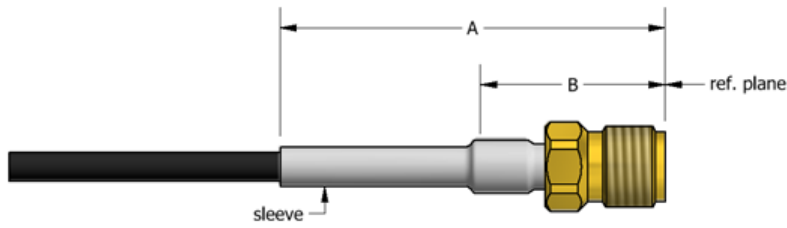

Symbols	Dimensions mm	
	Min	Max
A	19	33
B	14	14.4

NOTES:

- For connector interface dimensions, see Para. 1.6.3.

1.6.2.5 SMA, Female, Bulkhead Jack

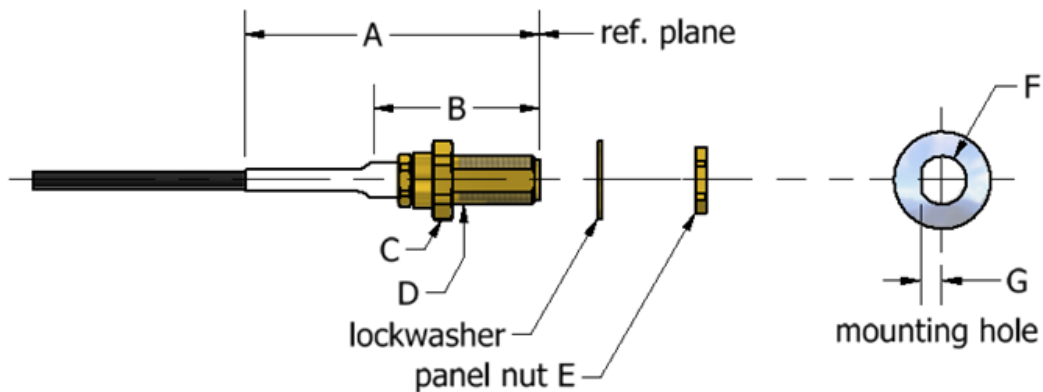

Symbols	Dimensions mm		Remarks
	Min	Max	
A	27	41	
B	21.4	21.8	
C	-	9.525	Hex
D	-	3.1	Maximum panel thickness
E	-	7.938	Hex
ØF	6.4	-	Mounting hole; 1 flat
G	2.7	-	

NOTES:

- For connector interface dimensions, see Para. 1.6.3.

1.6.3 Connector Interface Dimensions and Connector Interface Gauge Dimensions

- (a) SMA Male Connector Interface: compatible with series SMA pin contact interface as specified in [MIL-STD-348](#).
- (b) SMA Female Connector Interface: compatible with series SMA socket contact interface as specified in [MIL-STD-348](#).
- (c) SMA Male Gauge Interface: compatible with series SMA pin contact test connector interface as specified in [MIL-STD-348](#).
- (d) SMA Female Gauge Interface: compatible with series SMA socket contact test connector interface as specified in [MIL-STD-348](#).

1.7 ADD-ON COMPONENTS

1.7.1 Connectors

The connectors to be used in the components specified herein shall be RF coaxial connectors type SMA that meet the requirements of this specification and the ESCC Generic Specification.

1.7.2 Cable

The cable to be used in the components specified herein shall be 2.2mm outer diameter, RF ePTFE flexible coaxial cable that meets the requirements of this specification and the ESCC Generic Specification.

1.8 MATERIALS AND FINISHES

Materials and finishes shall be as follows.

1.8.1 Connectors

The materials and finishes applicable to the various connectors shall be as follows, as applicable to each connector type:

- (a) Body Shell: Beryllium copper, gold plated 1.3µm minimum.
- (b) Coupling Nut: Stainless steel, passivated.
- (c) Centre Contact: Beryllium copper, gold plated 2.5µm minimum
- (d) C Ring: Beryllium copper.
- (e) 90° Clip: Polyetheretherketone; colour: Black.
- (f) Gasket: fluoropolymer elastomer.
- (g) Sleeve: fluoropolymer; colour: white.
- (h) Lockwasher: Stainless steel, gold plated.
- (i) Panel Nut: Beryllium copper, gold plated.

1.8.2 Cable

The materials and finishes applicable to the cable shall be as follows:

- (a) Centre Conductor: Copper, silver plated 2µm minimum.
- (b) Dielectric Core: Expanded PTFE.
- (c) Electrical Shield: Copper, silver plated 1.06µm minimum.
- (d) Mechanical Shield: Copper, silver plated 1.06µm minimum.
- (e) Outer Jacket: Extruded ETFE; colour: black

2 REQUIREMENTS

2.1 GENERAL

The complete requirements for procurement of the components specified herein are as stated in this specification and the ESCC Generic Specification. Permitted deviations from the Generic Specification, applicable to this specification only, are listed below.

Permitted deviations from the Generic Specification and this Detail Specification, formally agreed with specific Manufacturers on the basis that the alternative requirements are equivalent to the ESCC requirement and do not affect the component's reliability, are listed in the appendices attached to this specification.

2.1.1 Deviations from the Generic Specification

2.1.1.1 *Deviations from Production Control – Chart F2*

- (a) Para. 8.8, Microsectioning of Strands: Silver plating thickness shall be as specified in the Detail Specification (see Para. 1.8.2 herein).

2.2 MARKING

The marking shall be in accordance with the requirements of ESCC Basic Specification No. [21700](#) and as follows.

The information to be marked on the component shall be:

- (a) The ESCC qualified components symbol (for ESCC qualified components only).
- (b) The ESCC Component Number (see Para. 1.4.1).
- (c) Traceability information.

2.3 ENVIRONMENTAL AND MECHANICAL TESTS

The following requirements apply to tests performed on the connector (and contact) lot, the cable lot and the cable assembly lot, as specified in the ESCC Generic Specification:

- (a) Para. 8.2, Contact Capability: Applicable only to connectors with female contacts. The following test requirements shall apply:

	Pick-up Test	Drop Test
Weight (g)	30 ±1	750 ±1
Test Pin Diameter (mm)	0.92 ±0.02	0.92 ±0.02
Insertion Depth (mm)	2.54 ±0.02	2.54 ±0.02

- (b) Para. 8.4, Plating Thickness: Plating thicknesses: see Para. 1.8.1.
- (c) Para. 8.5, Magnetism Level: Not applicable.
- (d) Para. 8.7, Insulation Flaws (Spark Test):
 - Applied voltage: 350Vrms
 - Frequency: 50 or 60Hz
- (e) Para. 8.11, Adhesion of Inner Conductor: 1N minimum.
- (f) Para. 8.12, Dielectric Strength of Jacket:
 - Test voltage: 64kV/mm
 - Frequency: N/A
- (g) Para. 8.13, Conductor Resistance: 90Ω/km maximum.
- (h) Para. 8.14, Capacitance: 85pf/m maximum.
- (i) Para. 8.15, Characteristic Impedance: 50 ±1Ω.
- (j) Para. 8.17.2.1, Temperature Cycling I (Chart F4A): Applicable to all Variants.
- (k) Para. 8.18, Coupling Proof Torque: See Para. 1.5.
- (l) Para. 8.19, Mating and Unmating Forces: 24Ncm maximum.
- (m) Para. 8.21, Multipaction: Shall not be performed.
- (n) Para. 8.26, Cable Retention Force: 66.8N.
- (o) Para. 8.27, Radiation: Applicable to all Variants.
 - Radiation source: Electron 3MeV
 - Radiation dosage: 10Mrad
 - Radiation test on the cable jacket:
 - Cable jacket dosage: 700Mrad
 - Data Points: On completion, a visual inspection under x10 magnification plus a tape test for any decomposition, shall be performed. The cable jacket material shall not exhibit any cracking, flaking or loose particles.
- (p) Para. 8.32, Corona: Shall not be performed
- (q) Para. 8.33, RF Power Handling: Shall not be performed.
- (r) Para. 8.34, RF Power Cycling: Shall not be performed.
- (s) Para. 8.36, Crimp Contact Tensile Strength: Not applicable.

2.4 ROOM TEMPERATURE ELECTRICAL MEASUREMENTS

The measurements shall be performed at $T_{amb} = +23 \pm 3^{\circ}\text{C}$.

Characteristics	Symbols	Test Method and Conditions	Limits		Units
			Min	Max	
Dielectric Withstanding Voltage	DWV	ESCC No. 3408 Note 1	350	-	Vrms
Voltage Proof Leakage Current	I_{VPL}	Note 2	-	200	μA
Insulation Resistance	R_i	ESCC No. 3408	2	-	G Ω
Voltage Standing Wave Ratio	VSWR	ESCC No. 3408 RF Power = 1mW			-
Variants 01, 05, 06, 19, 20, 21		f = DC to < 2GHz	-	1.15	
Variants 01, 05, 06, 19, 20, 21		f = 2 to < 4GHz	-	1.2	
Variants 01, 05, 06, 19, 20, 21		f = 4 to < 8GHz	-	1.3	
Variants 01, 05, 06, 19, 20, 21		f = 8 to < 12GHz	-	1.35	
Variants 01, 05, 06, 19, 20, 21		f = 12 to < 16GHz	-	1.35	
Variants 01, 05, 06, 19, 20, 21		f = 16 to < 18GHz	-	1.35	
Variants 01, 05, 06, 19, 20, 21		f = 18 to \leq 22GHz	-	1.45	
Variants 02, 03, 10, 11, 14, 15		f = DC to < 2GHz	-	1.2	
Variants 02, 03, 10, 11, 14, 15		f = 2 to < 4GHz	-	1.25	
Variants 02, 03, 10, 11, 14, 15		f = 4 to < 8GHz	-	1.35	
Variants 02, 03, 10, 11, 14, 15		f = 8 to < 12GHz	-	1.4	
Variants 02, 03, 10, 11, 14, 15		f = 12 to < 16GHz	-	1.4	
Variants 02, 03, 10, 11, 14, 15		f = 16 to < 18GHz	-	1.4	
Variants 02, 03, 10, 11, 14, 15		f = 18 to \leq 22GHz	-	1.5	
Variants 07, 08, 12		f = DC to < 2GHz	-	1.2	
Variants 07, 08, 12		f = 2 to < 4GHz	-	1.25	
Variants 07, 08, 12		f = 4 to < 8GHz	-	1.35	
Variants 07, 08, 12		f = 8 to < 12GHz	-	1.45	
Variants 07, 08, 12		f = 12 to < 16GHz	-	1.45	
Variants 07, 08, 12		f = 16 to < 18GHz	-	1.45	
Variants 07, 08, 12		f = 18 to \leq 22GHz	-	1.55	
Insertion Loss	IL	ESCC No. 3408, f = DC to 22GHz	-	Note 3	dB

NOTES:

1. Test voltage shall be applied between centre contact and the connector body of one of the connectors in the cable assembly.
2. Measured during Dielectric Withstanding Voltage.
3. IL maximum limits (in dB) shall be calculated as follows where the cable assembly length L is in metres and the test frequency f is in GHz:

$$IL \leq 0.06 + (0.0095 \times f) + (0.005 \times \sqrt{f}) + [(3.28084 \times L) \times (0.016 + \{0.0049 \times f\} + \{0.2035 \times \sqrt{f}\})]$$

N.B.

For components with a single 90° connector, Variants 02, 03, 10, 11, 14, 15, add 12.7mm to the length L when calculating IL.

For components with both 90° connectors, Variants 07, 08, 12, add 25.4mm to the length L when calculating IL.

2.5 INTERMEDIATE AND END-POINT ELECTRICAL MEASUREMENTS

Unless otherwise specified, the measurements shall be performed at $T_{amb} = +22 \pm 3^{\circ}\text{C}$

Unless otherwise specified, test methods and test conditions shall be as per the corresponding test defined in Para. 2.4 Room Temperature Electrical Measurements.

The drift values (Δ) shall not be exceeded for each characteristic where specified. The corresponding absolute limit values for each characteristic shall not be exceeded.

Test Reference per ESCC No. 3408	Characteristics	Symbols	Limits		Units
			Min	Max	
Temperature Cycling (I & II) Final Measurements	Voltage Standing Wave Ratio	VSWR	Note 1		
	Insertion Loss	IL	Note 1		
Electrical Measurements at Room, High and Low Temperatures	At room temperature: $T_{amb} = +22 \pm 3^{\circ}\text{C}$				
	Dielectric Withstanding Voltage	DWV	Note 1		
	Voltage Proof Leakage Current	I_{VPL}	Note 1		
	Insulation Resistance	I_R	Note 1		
	Voltage Standing Wave Ratio	VSWR	Note 1		
	Insertion Loss	IL	Note 1		
	At high temperature: $T_{amb} = +150 (+0 -5)^{\circ}\text{C}$				
	Dielectric Withstanding Voltage	DWV	Note 1		
	Voltage Proof Leakage Current	I_{VPL}	Note 1		
	Insulation Resistance	I_R	Note 1		
	Voltage Standing Wave Ratio	VSWR	Note 1		
	Change of Insertion Loss	$\Delta IL/IL$	-	+26	% (2)
At low temperature: $T_{amb} = -55 (+5 -0)^{\circ}\text{C}$					
Dielectric Withstanding Voltage	DWV	Note 1			
Voltage Proof Leakage Current	I_{VPL}	Note 1			
Insulation Resistance	I_R	Note 1			
Voltage Standing Wave Ratio	VSWR	Note 1			
Change of Insertion Loss	$\Delta IL/IL$	-	-23	% (2)	
Shielding Effectiveness	Shielding Effectiveness	SE			dB
	SMA, Male Connectors: SMA, Female Connectors:		90 80	- -	
Cable Retention Force Initial Measurement	Voltage Standing Wave Ratio	VSWR	Note 1		
	Final Measurement				
Final Measurement	Voltage Standing Wave Ratio	VSWR	Note 1		
	Insertion Loss	IL	Note 1		

Test Reference per ESCC No. 3408	Characteristics	Symbols	Limits		Units
			Min	Max	
Radiation Initial Measurement	Voltage Standing Wave Ratio	VSWR	Note 1		
	Insertion Loss	IL	Note 1		
Final Measurement	Dielectric Withstanding Voltage	DWV	Note 1		
	Voltage Proof Leakage Current	I _{VPL}	Note 1		
	Insulation Resistance	I _R	Note 1		
	Voltage Standing Wave Ratio	VSWR	Note 1		
Ageing	Insertion Loss	IL	Note 1		
	Voltage Standing Wave Ratio	VSWR	Note 1		
Bending	Insertion Loss	IL	Note 1		
	Voltage Standing Wave Ratio	VSWR	Note 1		
Random Vibration	Insertion Loss	IL	Note 1		
	Voltage Standing Wave Ratio	VSWR	Note 1		
Sine Vibration	Insertion Loss	IL	Note 1		
	Voltage Standing Wave Ratio	VSWR	Note 1		

NOTES:

1. The limits specified in Room Temperature Electrical Measurements, Para. 2.4, shall apply
2. Referenced to IL measured at room temperature in dB.

APPENDIX A

AGREED DEVIATIONS FOR W.L. GORE & ASSOCIATES Ltd (GB)

Items Affected	Description of Deviations
Para. 1.7 Add-on Components	<p>Para. 1.7.1, Connectors: Connector types as follows, as specified in the PID, ref. WLG-1320, shall apply:</p> <ul style="list-style-type: none"> • SMA, Male, Straight Plug: Gore type S01 (Gore Part Number: 8SS01) • SMA, Male, 90° Clip Plug: Gore type Y04 (Gore Part Number: 8SY04) • SMA, Male, 90° Box Plug: Gore type S71 (Gore Part Number: 8SS71) • SMA, Female, Straight Jack: Gore type S02 (Gore Part Number: 8SS02) • SMA, Female, Bulkhead Jack: Gore type R42 (Gore Part Number: 8SR42) <p>Para. 1.7.2, Cable: Gore cable type 8S, as specified in the PID, ref. WLG-1320, shall apply.</p>
Para. 2.1.1.1 Deviations from the Generic Specification – Production Control – Chart F2	<p>Para. 8.3, Gold Plate Porosity: shall only be performed if the contact lot is intended to be used to manufacture the RF cable assembly test vehicles used for Qualification Testing or Periodic Testing.</p> <p>Paras. 8.7, 8.10, 8.11, Insulation Flaws (Spark Test), Coating Tests, Adhesion of Inner Conductor: shall not be performed.</p> <p>Paras. 8.8, 8.12, 8.13, 8.14, 8.15, Microsectioning of Strands, Dielectric Strength of Jacket, Conductor Resistance, Capacitance, Characteristic Impedance: shall only be performed if the cable lot is intended to be used to manufacture the RF cable assembly test vehicles used for Qualification Testing or Periodic Testing.</p>
Para. 2.1.1 Deviations from the Generic Specification – Data Documentation	<p>Paras. 9.1,3, 9.5, 9.6, Additional Documentation, Add-on Components Documentation, Special In-Process Controls Data:</p> <p>If Add-on Components Documentation or Special In-Process Controls Data is stipulated in the Purchase Order, such data will not be delivered but will be available for review at Gore.</p>