



**CONTACTS, ELECTRICAL, CRIMP, FOR
3401/002, 3401/097 CONNECTORS**

ESCC Detail Specification No. 3401/005

Issue 9	November 2021
---------	---------------



LEGAL DISCLAIMER AND COPYRIGHT

European Space Agency, Copyright © 2021, All rights reserved.

The European Space Agency disclaims any liability or responsibility, to any person or entity, with respect to any loss or damage caused, or alleged to be caused, directly or indirectly by the use and application of this ESCC publication.

This publication, without prior permission of the European Space Agency and provided it is not used for a commercial purpose, may be:

- copied in whole, in any medium, without alteration or modification.
- copied in part, in any medium, provided that the ESCC document identification, comprising the ESCC symbol, document number and document issue, is removed.

DOCUMENTATION CHANGE NOTICE

(Refer to <https://escies.org> for ESCC DCR content)

DCR No.	CHANGE DESCRIPTION
1383	Specification updated to incorporate editorial changes per DCR.

TABLE OF CONTENTS

1	GENERAL	6
1.1	SCOPE	6
1.2	TYPE VARIANTS	6
1.3	MAXIMUM RATINGS	6
1.4	PARAMETER DERATING INFORMATION	6
1.5	PHYSICAL DIMENSIONS	6
2	APPLICABLE DOCUMENTS	7
3	TERMS, DEFINITIONS, ABBREVIATIONS, SYMBOLS AND UNITS	7
4	REQUIREMENTS	13
4.1	GENERAL	13
4.2	DEVIATIONS FROM GENERIC SPECIFICATION	13
4.2.1	Deviations from Special In-process Controls	13
4.2.2	Deviations from Final Production Tests - Chart II	13
4.2.3	Deviations from Burn-in and Electrical Measurements - Chart III	13
4.2.4	Deviations from Qualification Tests - Chart IV	13
4.2.5	Deviations from Lot Acceptance Tests - Chart V	13
4.3	MECHANICAL REQUIREMENTS	13
4.3.1	Dimension Check	13
4.3.2	Weight	13
4.3.3	Contact Capability	13
4.3.4	Contact Retention (In Insert)	13
4.3.5	Mating and Unmating Forces	13
4.3.6	Insert Retention (In Shell)	13
4.3.7	Jackscrew Retention	14
4.3.8	Contact Insertion and Withdrawal Forces	14
4.3.9	Engagement and Separation Forces	14
4.3.10	Oversize Pin Exclusion	14
4.3.11	Probe Damage	14
4.3.12	Solderability	14
4.4	MATERIALS AND FINISHES	14
4.4.1	Shells	14
4.4.2	Inserts	14
4.4.3	Contacts	14
4.4.4	Contact Retaining Clip	14
4.4.5	Guiding and Locking Devices	14
4.4.6	Magnetism Level	14

4.5	MARKING	15
4.5.1	General	15
4.5.2	The ESCC Component Number	15
4.5.3	Traceability Information	15
4.6	ELECTRICAL MEASUREMENTS	15
4.6.1	Electrical Measurements at Room Temperature	15
4.6.2	Electrical Measurements at High and Low Temperatures (Table 3)	15
4.6.3	Circuits for Electrical Measurements (Figure 4)	15
4.7	BURN-IN AND ELECTRICAL MEASUREMENTS (TABLES 4 AND 5)	15
4.8	ENVIRONMENTAL AND ENDURANCE TESTS	15
4.8.1	Measurements and Inspections on Completion of Environmental Tests	15
4.8.2	Measurements and Inspections at Intermediate Points during Endurance Tests	15
4.8.3	Measurements and Inspections on Completion of Endurance Tests	16
4.8.4	Conditions for Operating Life Test (Part of Endurance Testing)	16
4.8.5	Electrical Circuits for Operating Life Test	16
4.8.6	Conditions for High Temperature Storage Test (Part of Endurance Testing)	16
	APPENDIX A	19

1 GENERAL

1.1 SCOPE

This specification details the ratings, physical and electrical characteristics, test and inspection data for Contacts, Electrical, Crimp, Gauge 20 and 22, for [3401/002](#) and [3401/097](#) Connectors.

These contacts shall be packed separately from the connectors and may be procured either with the connectors or separately.

This specification shall be read in conjunction with:

- ESCC Generic Specification No. [3401](#), Connectors, Electrical, Non-Filtered, Circular and Rectangular,
- ESCC Detail Specification No. [3401/002](#), Connectors, Electrical, Rectangular, Removable Crimp Contacts, Based on Type D*MA,
- ESCC Detail Specification No. [3401/097](#), Connecting Pieces, Electrical, for Wires with Standard Density Removable Crimp Contacts, Based on Type Space Splice,

the requirements of which are supplemented herein.

1.2 TYPE VARIANTS

The different sizes of contacts specified herein, which are also covered by this specification, are scheduled in Table 1(a).

1.3 MAXIMUM RATINGS

The maximum ratings, which shall not be exceeded at any time during use or storage, applicable to the contacts specified herein, are as scheduled in Table 1(b).

1.4 PARAMETER DERATING INFORMATION

Not applicable.

1.5 PHYSICAL DIMENSIONS

The physical dimensions of the contacts specified herein are shown in Figure 2.

2 APPLICABLE DOCUMENTS

The following documents form part of this specification and shall be read in conjunction with it:

- (a) ESCC Generic Specification No. [3401](#), Connectors, Electrical, Non-Filtered, Circular and Rectangular.
- (b) ESCC Detail Specification No. [3401/002](#), Connectors, Electrical, Rectangular, Removable Crimp Contacts, Based on Type D*MA.
- (c) ESCC Detail Specification No. [3401/097](#), Connecting Pieces, Electrical, for Wires with Standard Density Removable Crimp Contacts, Based on Type Space Splice,
- (d) MIL-G-45204, Gold Plating, Electro-deposited.
- (e) MIL-C-14450, Copper Plating, Electro-deposited.
- (f) MIL-DTL-81969/39, Detail Specification Sheet, Installing and Removal Tool, Connector Electrical Contacts, Type III, Class 2, Composition B.
- (g) MIL-I-81969/14, Detail Specification Sheet, Installing and Removal Tool, Connector Electrical Contacts, Type III, Class 2, Composition B.

3 TERMS, DEFINITIONS, ABBREVIATIONS, SYMBOLS AND UNITS

For the purpose of this specification, the terms, definitions, abbreviations, symbols and units specified in ESCC Basic Specification No. [21300](#) shall apply.

TABLE 1(A) – TYPE VARIANTS

Variant	Type	Mating End Size	Crimp Barrel Size	Rated Current A	Accept Wire AWG	Max. Weight g	Engagement & Separation				Contact Capability	
							Engag. Forces N (1)	Separ. Forces N (1)	Test Pins Dia. mm		Weight	
									Min.	Max.	Pick-up (2) g	Drop (3) g
01	Male	20	20	7.5	20	0.16	-	-	-	-	-	-
02	Female					0.18	3.33	2.22	1.039	1.040	-	226.8
03	Male	20	26	3	26	0.18	-	-	-	-	-	-
04	Female					0.21	3.33	2.22	1.039	1.040	-	226.8
05	Male	20	18	7.5	18	0.3	-	-	-	-	-	-
06	Female					0.32	3.33	2.22	1.039	1.040	-	226.8
07 ⁽⁴⁾	Male	22	22	5	22	0.08	-	-	-	-	-	-
08 ⁽⁵⁾	Female					0.11	3.33	2.22	0.773	0.775	-	226.8
09 ⁽⁴⁾	Male	22	22	5	22	0.08	-	-	-	-	-	-
10 ⁽⁵⁾	Female					0.11	3.33	2.22	0.773	0.775	-	226.8

Variant	Contact Retention Force Max. N	Contact Insertion and Withdrawal Forces Max. N	Probe Damage			Oversize Pin Excl.		
			Moment N.cm	Probe Dia. mm		Force Max. N	Test Pin Dia. mm	
				Min.	Max.		Min.	Max.
01	40	18.5	-	-	-	-	-	-
02	40	18.5	5.65	1.007	1.033	3.33	1.166	1.17
03	40	18.5	-	-	-	-	-	-
04	40	18.5	5.65	1.007	1.033	3.33	1.166	1.17
05	40	18.5	-	-	-	-	-	-
06	40	18.5	5.65	1.007	1.033	3.33	1.166	1.17
07 ⁽⁴⁾	40	18.5	-	-	-	-	-	-
08 ⁽⁵⁾	40	18.5	1.3	0.749	0.774	2.43	0.905	0.907
09 ⁽⁴⁾	40	18.5	-	-	-	-	-	-
10 ⁽⁵⁾	40	18.5	1.3	0.749	0.774	2.43	0.905	0.907

NOTES:

- 1st line, maximum values with maximum diameter test pin; 2nd line, minimum values with minimum diameter test pin.
- With minimum diameter test pin and minimum insertion depth of 4mm.
- With maximum diameter test pin and minimum insertion depth of 4mm.
- See Figure 2 for dimension difference details between Variants 07 and 09.
- See Figure 2 for dimension difference details between Variants 08 and 10

TABLE 1(b) – MAXIMUM RATINGS

No.	Characteristics	Symbol	Maximum Rating		Unit
			Min.	Max.	
1	Rated Current	I_{CR}	-	See Table 1(a)	A
2	Operating Temperature Range	T_{op}	-55	+125	°C
3	Storage Temperature Range	T_{stg}	-65	+125	°C

FIGURE 1 – PARAMETER DERATING INFORMATION

Not applicable

FIGURE 2 – PHYSICAL DIMENSIONS

VARIANTS 01 AND 03 – MALE CONTACTS

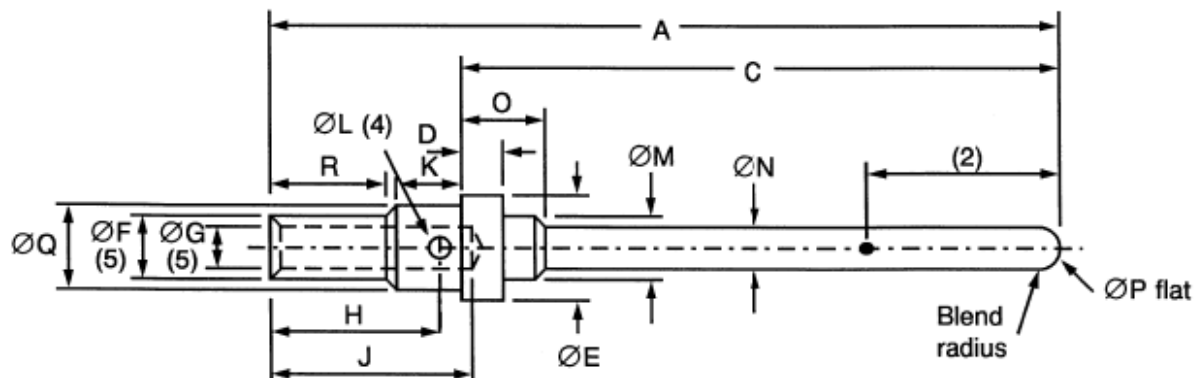

	A	<u>C</u>	D	<u>ØE</u>	ØF	<u>ØG</u> (6)	H	J	K	ØL	ØM	<u>ØN</u>	<u>Ø</u>	ØP	<u>ØQ</u>	R
Min.	-	9.8	0.72	2.08	1.65	1.09	3.4	3.8	1.01	0.6	1.78	0.99	1.65	-	1.7	2.4
Max.	14.14	10	0.86	2.16	1.73	1.17	3.68	4.7	1.25	0.8	1.85	1.04	1.75	0.3	1.8	-

NOTES:

1. All dimensions are in millimetres.
2. Measurement point for plating thickness: 4±1.
3. Underlined dimensions, in table, are critical to ensure intermateability and interchangeability.
4. Inspection hole shall only penetrate one wall of the crimp barrel. May be square, i.e. L×L.
5. ØF and ØG to be concentric within 0.04.
6. ØG of Variant 03 shall be 0.59 minimum, 0.66 maximum.
7. ØL of Variant 03 shall be 0.45 minimum, 0.55 maximum.

VARIANTS 02 AND 04 – FEMALE CONTACTS

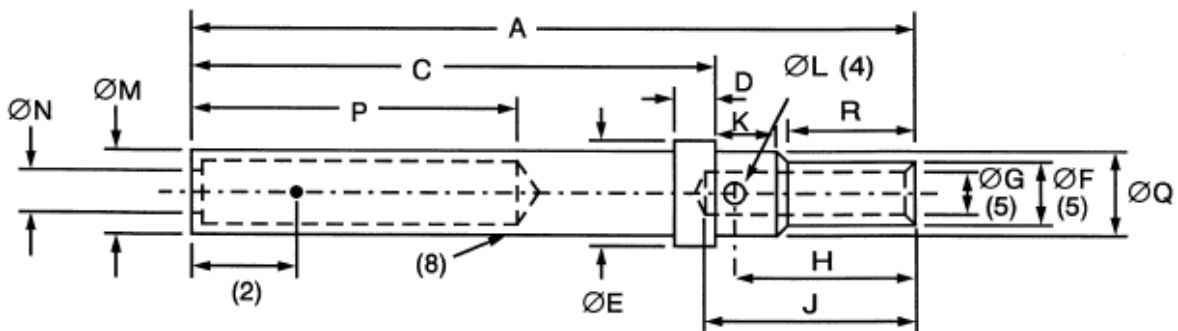

	A	<u>C</u>	D	<u>ØE</u>	<u>ØF</u>	<u>ØG</u> (6)	H	J	K	<u>ØL</u> (7)	<u>ØM</u>	<u>ØN</u>	<u>P</u>	<u>ØQ</u>	R
Min.	-	9.45	0.72	2.08	1.65	1.09	3.4	3.8	1.01	0.6	1.7	1.07	7	1.7	2.4
Max.	13.8	9.65	0.86	2.16	1.73	1.17	3.68	4.7	1.25	0.8	1.85	1.14	-	1.8	-

NOTES:

1. All dimensions are in millimetres.
2. Measurement point for plating thickness: 2±1.
3. Underlined dimensions, in table, are critical to ensure intermateability and interchangeability.
4. Inspection hole shall only penetrate one wall of the crimp barrel. May be square, i.e. L×L.
5. ØF and ØG to be concentric within 0.04.
6. ØG of Variant 04 shall be 0.59 minimum, 0.66 maximum.
7. ØL of Variant 04 shall be 0.45 minimum, 0.55 maximum.
8. The mechanical pressure member shall be shrouded. Sleeve, if used, shall conform to the applicable requirements.

VARIANT 05 – MALE CONTACT

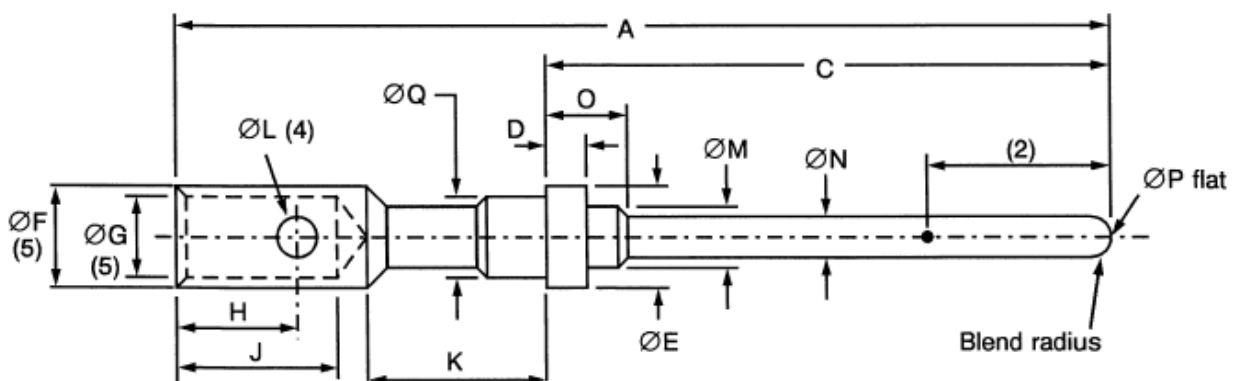

	A	<u>C</u>	D	<u>ØE</u>	<u>ØF</u>	<u>ØG</u>	H	J	K	<u>ØL</u>	<u>ØM</u>	<u>ØN</u>	<u>Q</u>	<u>ØP</u>	<u>ØQ</u>
Min.	-	9.8	0.72	2.08	2.09	1.65	3.8	4.32	6.15	0.6	1.78	0.99	1.65	-	1.7
Max.	21.13	10	0.86	2.16	2.18	1.74	4	4.7	6.45	0.8	1.85	1.04	1.75	0.3	1.8

NOTES:

1. All dimensions are in millimetres.
2. Measurement point for plating thickness: 4±1.
3. Underlined dimensions, in table, are critical to ensure intermateability and interchangeability.
4. Inspection hole shall only penetrate one wall of the crimp barrel. May be square, i.e. L×L.
5. ØF and ØG to be concentric within 0.04.

VARIANT 06 – FEMALE CONTACT

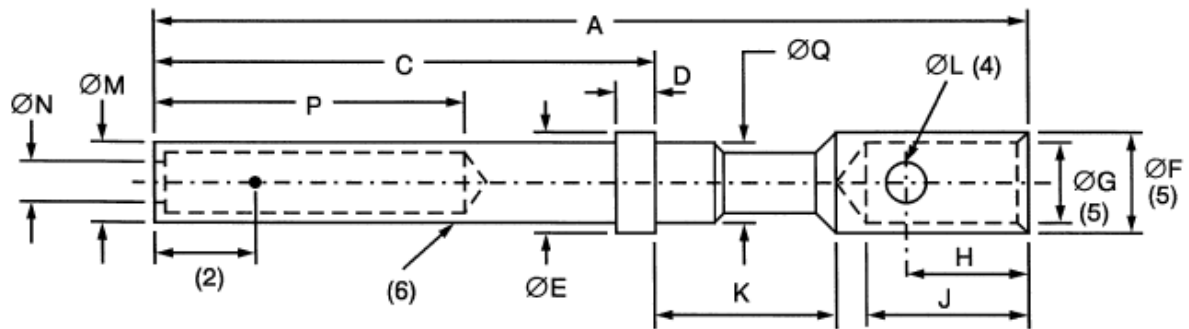

	A	<u>C</u>	D	<u>ØE</u>	ØF	<u>ØG</u>	H	J	K	ØL	ØM	<u>ØN</u>	<u>P</u>	<u>ØQ</u>
Min.	-	9.45	0.72	2.08	2.09	1.65	3.8	4.32	6.15	0.6	1.7	1.07	7	1.7
Max.	20.8	9.65	0.86	2.16	2.18	1.74	4	4.7	6.45	0.8	1.85	1.14	-	1.8

NOTES:

1. All dimensions are in millimetres.
2. Measurement point for plating thickness: 2±1.
3. Underlined dimensions, in table, are critical to ensure intermateability and interchangeability.
4. Inspection hole shall only penetrate one wall of the crimp barrel. May be square, i.e. L×L.
5. ØF and ØG to be concentric within 0.04.
6. The mechanical pressure member shall be shrouded. Sleeve, if used, shall conform to the applicable requirements.

VARIANTS 07 AND 09 – MALE CONTACT

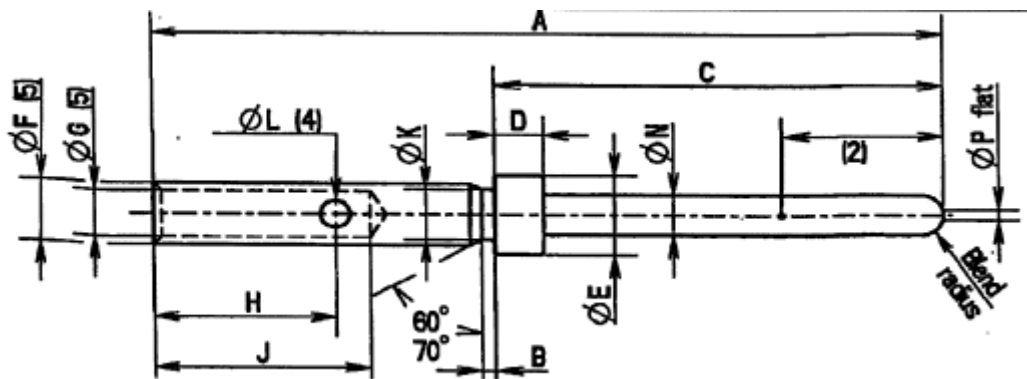

	A	B		<u>C</u>	<u>D</u>	<u>ØE</u>	ØF	<u>ØG</u>	H	J	ØK	ØL	<u>ØN</u>	ØP
		Variant 07	Variant 09											
Min.	-	0.2	0.1	7.49	0.74	1.52	1.17	0.85	3.09	3.58	0.91	0.46	0.75	-
Max.	13.64	0.25	0.25	7.62	0.84	1.57	1.22	0.9	3.27	3.99	1.01	0.56	0.77	0.2

NOTES:

1. All dimensions are in millimetres.
2. Measurement point for plating thickness: 4±1.
3. Underlined dimensions, in table, are critical to ensure intermateability and interchangeability.
4. Inspection hole shall only penetrate one wall of the crimp barrel. May be square, i.e. L×L.
5. ØF and ØG to be concentric within 0.04.

VARIANTS 08 AND 10 – FEMALE CONTACT

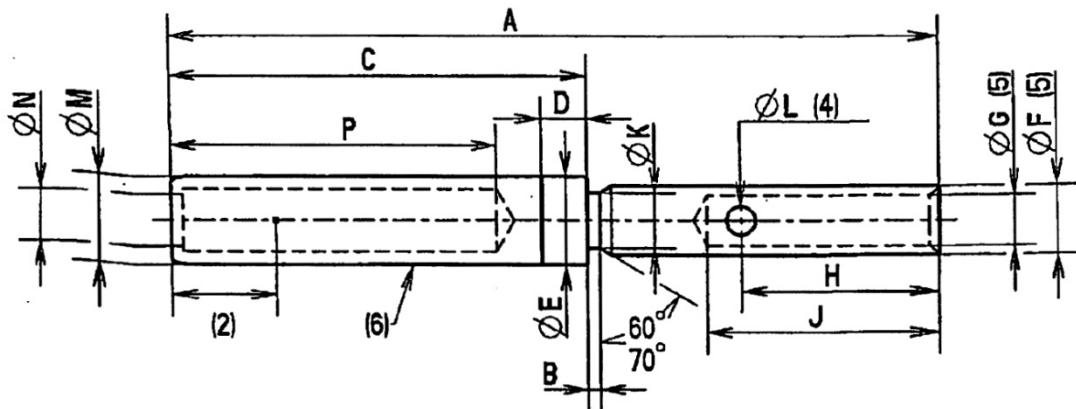

	A	B		<u>C</u>	<u>D</u>	<u>ØE</u>	ØF	ØG	H	J	ØK	ØL	ØM	<u>ØN</u>	ØP
		Variant 08	Variant 10												
Min.	-	0.2	0.1	7.08	0.74	1.52	1.17	0.85	3.09	3.58	0.91	0.46	-	0.78	4.22
Max.	13.41	0.25	0.25	7.34	0.84	1.57	1.22	0.9	3.27	3.99	1.01	0.56	1.57	-	-

NOTES:

1. All dimensions are in millimetres.
2. Measurement point for plating thickness: 2±1.
3. Underlined dimensions, in table, are critical to ensure intermateability and interchangeability.
4. Inspection hole shall only penetrate one wall of the crimp barrel. May be square, i.e. L×L.
5. ØF and ØG to be concentric within 0.04.
6. The mechanical pressure member shall be shrouded. Sleeve, if used, shall conform to the applicable requirements.

4 REQUIREMENTS

4.1 GENERAL

The complete requirements for procurement of the contacts specified herein are stated in this specification and ESCC Generic Specification No. 3401. Deviations from the Generic Specification, applicable to this specification only, are listed in Para. 4.2.

Deviations from the applicable Generic Specification and this Detail Specification, formally agreed with specific Manufacturers on the basis that the alternative requirements are equivalent to the ESCC requirements and do not affect the components' reliability, are listed in the appendices attached to this specification.

4.2 DEVIATIONS FROM GENERIC SPECIFICATION

4.2.1 Deviations from Special In-process Controls

None.

4.2.2 Deviations from Final Production Tests - Chart II

None.

4.2.3 Deviations from Burn-in and Electrical Measurements - Chart III

Chart III is not applicable.

4.2.4 Deviations from Qualification Tests - Chart IV

(a) Para. 9.31, Solderability: Not applicable.

4.2.5 Deviations from Lot Acceptance Tests - Chart V

(a) Para. 9.31, Solderability: Not applicable.

4.3 MECHANICAL REQUIREMENTS

4.3.1 Dimension Check

The dimensions of the contacts specified herein shall be verified in accordance with the requirements set out in Para. 9.6 of ESCC Generic Specification No. 3401 and shall conform to those shown in Figure 2 of this specification. Only the underlined dimensions shall be checked during procurement.

4.3.2 Weight

The maximum weight of the contacts specified herein shall be as specified in Table 1(a).

4.3.3 Contact Capability

For the purpose of this test, the pick-up and drop weights shall be as specified in Table 1(a).

4.3.4 Contact Retention (In Insert)

The contact retention force shall be as specified in Table 1(a).

4.3.5 Mating and Unmating Forces

As specified in ESCC Detail Specification No. 3401/002.

4.3.6 Insert Retention (In Shell)

As specified in ESCC Detail Specification No. 3401/002.

4.3.7 Jackscrew Retention

As specified in ESCC Detail Specification No. [3401/002](#).

4.3.8 Contact Insertion and Withdrawal Forces

The contact insertion and withdrawal forces shall be as specified in Table 1(a).

NOTE: Contacts shall be inserted and removed using the applicable tool as follows or equivalent:

- For size 20 contacts: M81969/39-01 in accordance with MIL-DTL-81969/39
- For size 22 contacts: M81969/14-01 in accordance with MIL-I-81969/14

4.3.9 Engagement and Separation Forces

The diameter of the test pin and the engagement and separation forces of the female contacts shall be as specified in Table 1(a).

4.3.10 Oversize Pin Exclusion

The diameter of the test pin and the force applied to it shall be as specified in Table 1(a).

4.3.11 Probe Damage

The probe diameter and the moment at the end of the probe shall be as specified in Table 1(a).

4.3.12 Solderability

Not applicable.

4.4 MATERIALS AND FINISHES

The materials and finishes shall be as specified herein. Where a definite material is not specified, a material which will enable the components specified herein to meet the performance requirements of this specification shall be used. Acceptance or approval of any constituent material does not guarantee acceptance of the finished product.

4.4.1 Shells

As specified in ESCC Detail Specification No. [3401/002](#).

4.4.2 Inserts

As specified in ESCC Detail Specification No. [3401/002](#).

4.4.3 Contacts

The contact body shall be made of copper alloy with an underplate of 1µm minimum of non-magnetic nickel or copper to MIL-C-14450, gold plated with 1.27µm minimum of gold, Type 2 Grade C of MIL-G-45204.

The female contact spring element shall be made of copper alloy with an underplate of 1µm minimum of nickel or copper to MIL-C-14450, gold plated with 1.27µm minimum of gold, Type 2 Grade C of MIL-G-45204.

4.4.4 Contact Retaining Clip

As specified in ESCC Detail Specification No. [3401/002](#).

4.4.5 Guiding and Locking Devices

As specified in ESCC Detail Specification No. [3401/002](#).

4.4.6 Magnetism Level

As specified in ESCC Detail Specification No. [3401/002](#).

4.5 MARKING

4.5.1 General

The marking of all components delivered to this specification shall be in accordance with the requirements of ESCC Basic Specification No. 21700 and the following subparagraphs.

These components being too small to accommodate the marking as specified hereafter, the full marking information shall accompany each lot of components in its primary package. Such marking shall comprise:

- (a) The ESCC qualified components symbol (for ESCC qualified components only).
- (b) The ESCC Component Number.
- (c) Traceability information.

4.5.2 The ESCC Component Number

The ESCC Component Number shall be constituted and marked as follows:

Example: 340100501B

- Detail Specification Number: 3401005
- Type Variant (see Table 1(a)): 01 (as required)
- Testing Level: B.

4.5.3 Traceability Information

Traceability information shall be marked in accordance with the requirements of ESCC Basic Specification No. [21700](#).

4.6 ELECTRICAL MEASUREMENTS

4.6.1 Electrical Measurements at Room Temperature

The parameters to be measured in respect of electrical characteristics are scheduled in Table 2. Unless otherwise specified, these measurements shall be performed at $T_{amb} = +22 \pm 3$ °C.

4.6.2 Electrical Measurements at High and Low Temperatures (Table 3)

Not applicable.

4.6.3 Circuits for Electrical Measurements (Figure 4)

Not applicable.

4.7 BURN-IN AND ELECTRICAL MEASUREMENTS (TABLES 4 AND 5)

Not applicable.

4.8 ENVIRONMENTAL AND ENDURANCE TESTS

4.8.1 Measurements and Inspections on Completion of Environmental Tests

The parameters to be measured and inspections to be performed on completion of environmental testing are scheduled in Table 6. Unless otherwise specified, these measurements shall be performed at $T_{amb} = +22 \pm 3$ °C.

4.8.2 Measurements and Inspections at Intermediate Points during Endurance Tests

Not applicable.

4.8.3 Measurements and Inspections on Completion of Endurance Tests

The parameters to be measured and inspections to be performed on completion of endurance tests shall be those specified in Table 6. Unless otherwise specified, these measurements shall be performed at $T_{amb} = +22 \pm 3 \text{ }^\circ\text{C}$.

4.8.4 Conditions for Operating Life Test (Part of Endurance Testing)

Not applicable.

4.8.5 Electrical Circuits for Operating Life Test

Not applicable.

4.8.6 Conditions for High Temperature Storage Test (Part of Endurance Testing)

The requirements for the high temperature storage test are specified in Section 9 of ESCC Generic Specification No. 3401. The conditions for high temperature storage testing shall be the maximum storage temperature specified in Table 1(b) of this specification.

TABLE 2 – ELECTRICAL MEASUREMENTS AT ROOM TEMPERATURE

No.	Characteristics	Symbol	Specification and/or Test Method	Test Condition	Variants	Limits		Unit
						Min.	Max.	
1	Contact Resistance (Low Level Current)	Rcl	ESCC 3401 Para. 9.1.1.3	Para. 9.1.1.3	All	-	6	mΩ
2	Contact Resistance (Rated Current)	Rcr	ESCC 3401 Para. 9.1.1.3	Para. 9.1.1.3				
				7.5A	01, 02, 05, 06	-	5	mΩ
				3A	03, 04	-	5	mΩ
				5A	07, 08, 09, 10	-	5	mΩ

TABLES 3, 4 AND 5

Not applicable

TABLE 6 – MEASUREMENTS AND INSPECTIONS ON COMPLETION OF ENVIRONMENTAL AND ENDURANCE TESTS

No.	ESCC Generic No. 3401		Measurements and Inspections		Symbol	Limits		Unit
	Environmental and Endurance Tests (1)	Test Method and Conditions	Identification	Conditions		Min.	Max.	
01	Wiring	Para. 9.10 & Table 1(a) of this spec.	Low Level Contact Resistance	Table 2 Item 1	Rcl	Table 2 Item 1		
02	Vibration	Para. 9.11	ESCC 3401/002					
03	Shock or Bump	Para. 9.12	ESCC 3401/002					
04	Climatic Sequence	Para. 9.13	ESCC 3401/002					
05	Seal Test	Para. 9.9	ESCC 3401/002					
06	Plating Thickness	Para. 9.14	Thickness	-	-	Para. 4.4.3 of this spec		
07	Joint Strength	Para. 9.15	ESCC 3401 Para. 9.15					
08	Rapid Change of Temperature	Para. 9.16	ESCC 3401/002					
09	Contact Retention (in Insert)	Para. 9.17 & Para. 4.3.4 of spec.	Contact Displacement	-	-	ESCC 3401 Para. 9.17		
10	Endurance	Para. 9.18	Initial Measurements Low Level Contact Resistance	Table 2 Item 1	Rcl	Record Values		mΩ
			Final Measurements Low Level Contact Resistance Drift	Table 2 Item 1	ΔRcl	-	3	mΩ
11	Permanence of Marking	Para. 9.19	As applicable					
12	Mating/Unmating Forces	Para. 9.20	ESCC 3401/002					
13	High Temperature Storage	Para. 9.21	Initial Measurements Low Level Contact Resistance	Table 2 Item 1	Rcl	Record Values		mΩ
			Final Measurements Low Level Contact Resistance Drift	Table 2 Item 1	ΔRcl	-	3	mΩ
			Rated Current Contact Resistance	Table 2 Item 2	Rcr	Table 2 Item 2		
			Contact Retention (in Insert)	Para. 4.3.4 of this spec.	-	ESCC 3401 Para. 9.17		
14	Corrosion	Para. 9.22	Visual Examination	-	-	-	-	
15	Insert Retention (in Shell)	Para. 9.23 & Para. 4.3.6 of this spec.	ESCC 3401/002					
16	Jackscrew Retention	Para. 9.24 & Para. 4.3.7 of this spec.	ESCC 3401/002					
17	High Temperature Measurements	Para. 9.25	ESCC 3401/002					
18	Overload Test	Para. 9.26	Rated Current Contact Resistance	Table 2 Item 2	Rcr	Table 2 Item 2		

No.	ESCC Generic No. 3401		Measurements and Inspections		Symbol	Limits		Unit
	Environmental and Endurance Tests (1)	Test Method and Conditions	Identification	Conditions		Min.	Max.	
19	Maintenance Aging	Para. 9.27	Visual Examination Contact Retention Contact Insertion & Withdrawal Forces	- Para. 4.3.4 of this spec. Para. 4.3.8 of this spec.	- - -	- ESCC 3401 Para. 9.17 Para. 4.3.8	-	
20	Engage/Separation Forces	Para. 9.28 & Para. 4.3.9 of this spec.	Force	-	-	Para. 4.3.9		
21	Oversize Pin Exclusion	Para. 9.29 & Para. 4.3.10 of this spec.				ESCC 3401 Para. 9.29		
22	Probe Damage	Para. 9.30 & Para. 4.3.11 of this spec.	Contact Separation Force	Para. 4.3.9 of this spec.	-	Para. 4.3.9		
23	Solderability	Para. 9.31 & Para. 4.3.12 of this spec.	Not applicable					

NOTES:

1. The tests in this Table refer to either Chart IV or V and shall be used as applicable.

APPENDIX A
AGREED DEVIATIONS FOR C&K COMPONENTS (F)

Items Affected	Description of Deviations
Para. 4.2.2, Deviations from Final Production Tests - Chart II	Para. 9.4, Contact Capability: 100% Contact Capability Test may be omitted provided that a 100% visual inspection of the contact and a 10% Contact Capability test are performed in accordance with the C&K PID requirements. The results of the Contact Capability test shall be considered for PDA.