



**RESISTANCE TEMPERATURE DETECTOR THIN FILM
PLATINUM SENSOR, PTC,
RANGE 100 TO 2000 OHMS AT 0°C, WITH
A TEMPERATURE RANGE OF -200°C TO +200°C**

ESCC Detail Specification No. 4006/015

Issue 4	February 2022
---------	---------------



LEGAL DISCLAIMER AND COPYRIGHT

European Space Agency, Copyright © 2022. All rights reserved.

The European Space Agency disclaims any liability or responsibility, to any person or entity, with respect to any loss or damage caused, or alleged to be caused, directly or indirectly by the use and application of this ESCC publication.

This publication, without the prior permission of the European Space Agency and provided that it is not used for a commercial purpose, may be:

- copied in whole, in any medium, without alteration or modification.
- copied in part, in any medium, provided that the ESCC document identification, comprising the ESCC symbol, document number and document issue, is removed.

DOCUMENTATION CHANGE NOTICE

(Refer to <https://escies.org> for ESCC DCR content)

DCR No.	CHANGE DESCRIPTION
1477	Specification updated to incorporate changes per DCR

TABLE OF CONTENTS

1	GENERAL	6
1.1	SCOPE	6
1.2	APPLICABLE DOCUMENTS	6
1.3	TERMS, DEFINITIONS, ABBREVIATIONS, SYMBOLS AND UNITS	6
1.4	THE ESCC COMPONENT NUMBER AND COMPONENT TYPE VARIANTS	6
1.4.1	THE ESCC COMPONENT NUMBER	6
1.4.1.1	CHARACTERISTIC CODES	7
1.4.2	COMPONENT TYPE VARIANTS AND RANGE OF COMPONENTS	8
1.5	MAXIMUM RATINGS	10
1.6	HANDLING PRECAUTIONS	10
1.7	PHYSICAL DIMENSIONS	11
1.7.1	COMPONENTS WITH PLATINUM LEADS ONLY – TERMINATION TYPE CODE 00	11
1.7.2	COMPONENTS WITH EXTENSION CABLE/WIRES – TERMINATION TYPE CODES 01, 02, 03, 04, 0511	
1.7.2.1	COMPONENTS WITH TWISTED 2-CORE EXTENSION CABLE (NO SHIELD) – TERMINATION TYPE CODE 01	12
1.7.2.2	COMPONENTS WITH TWISTED 4-CORE EXTENSION CABLE (NO SHIELD) – TERMINATION TYPE CODE 02	13
1.7.2.3	COMPONENTS WITH TWISTED 2-CORE EXTENSION CABLE WITH SHIELD AND JACKET – TERMINATION TYPE CODE 03	14
1.7.2.4	COMPONENTS WITH TWISTED 4-CORE EXTENSION CABLE WITH SHIELD AND JACKET – TERMINATION TYPE CODE 04	15
1.7.2.5	COMPONENTS WITH 2-WIRE EXTENSION – TERMINATION TYPE CODE 05	16
1.8	FUNCTIONAL DIAGRAM	17
1.9	MATERIALS AND FINISHES	17
1.9.1	BODY	17
1.9.2	LEAD MATERIAL AND FINISH	17
1.9.2.1	PLATINUM SENSOR LEADS	17
1.9.2.2	EXTENSION CABLE/WIRES	17
1.9.3	HEAT-SHRINK TUBING	17
1.10	WEIGHT	18
2	REQUIREMENTS	18
2.1	GENERAL	18
2.1.1	DEVIATIONS FROM THE GENERIC SPECIFICATION	18
2.1.1.1	DEVIATIONS FROM SPECIAL IN-PROCESS CONTROLS – CHART F2	18
2.1.1.2	DEVIATIONS FROM SCREENING TESTS – CHART F3	18
2.1.1.3	DEVIATIONS FROM QUALIFICATION AND PERIODIC TESTS - CHART F4	19
2.2	MARKING	19
2.3	THERMAL SHOCK	19



2.4	TERMINAL STRENGTH	19
2.5	ELECTRICAL MEASUREMENTS AT ROOM, HIGH AND LOW TEMPERATURES	20
2.5.1	ROOM TEMPERATURE ELECTRICAL MEASUREMENTS	20
2.5.2	HIGH AND LOW TEMPERATURES ELECTRICAL MEASUREMENTS	20
2.6	PARAMETER DRIFT VALUES	21
2.7	INTERMEDIATE AND END-POINT ELECTRICAL MEASUREMENTS	21
2.8	BURN-IN CONDITIONS	22
2.9	OPERATING LIFE CONDITIONS	22
	APPENDIX 'A'	23

1 GENERAL

1.1 SCOPE

This specification details the ratings, physical and electrical characteristics and test and inspection data for the component type variants and/or the range of components specified below. It supplements the requirements of, and shall be read in conjunction with, the ESCC Generic Specification listed under Applicable Documents.

1.2 APPLICABLE DOCUMENTS

The following documents form part of this specification and shall be read in conjunction with it:

- (a) ESCC Generic Specification No. [4006](#), Thermistors (Thermally Sensitive Resistors).

1.3 TERMS, DEFINITIONS, ABBREVIATIONS, SYMBOLS AND UNITS

For the purpose of this specification, the terms, definitions, abbreviations, symbols and units specified in ESCC Basic Specification No. [21300](#) shall apply.

1.4 THE ESCC COMPONENT NUMBER AND COMPONENT TYPE VARIANTS

1.4.1 The ESCC Component Number

The ESCC Component Number shall be constituted and marked as follows:

Example 1: Sensor with platinum leads only (no extension cable/wires):

40060150100-0000

- Detail Specification Reference: 4006015
- Component Type Variant Number: 01 (as required)
- Characteristic Code: Termination Type (platinum leads, no extension cable/wires): 00
- Characteristic Code: Heat-shrink Tubing Type (N/A): -
- Characteristic Code: Extension Cable/Wires Nominal Total Length (N/A): 0000

Example 2: Sensor with extension cable/wires:

40060151001B0999

- Detail Specification Reference: 4006015
- Component Type Variant Number: 10 (as required)
- Characteristic Code: Termination Type (twisted 2-core extension cable): 01 (as required)
- Characteristic Code: Heat-shrink Tubing Type (Kynar): B (as required)
- Characteristic Code: Extension Cable/Wires Nominal Total Length (TL = 999mm): 0999 (as required)

1.4.1.1 **Characteristic Codes**

Characteristics to be codified as part of the ESCC Component Number shall be as follows:

(a) **Termination Type**

The following termination types, expressed by the following codes, are available:

Termination Type Description	Code	Applicable Extension Cable/Wires (ESCC Component Number) (Note 1)
Platinum leads only (no extension cable/wires)	00	N/A
Twisted 2-core extension cable (no shield)	01	390101910B
Twisted 4-core extension cable (no shield)	02	390101926B
Twisted 2-core extension cable with shield and jacket	03	390101957B
Twisted 4-core extension cable with shield and jacket	04	390101973B
2-wire extension (single extension wires)	05	390101902B

NOTES:

1. In accordance with ESCC Detail Specification No. [3901/019](#).

(b) **Heat-shrink Tubing Type**

The following heat-shrink tubing types, expressed by the following codes, are available:

Heat-shrink Tubing Type	Code	Remarks
N/A	-	Applicable to components with Platinum leads only (i.e., Termination Type Code: 00)
2 Layers of TFE-R Tubing (Note 1)	A	Applicable to components with extension cable/wires (i.e., Termination Type Codes: 01, 02, 03, 04 05) Note: Tubing operating temperature range: -67°C to +250°C
2 Layers of Kynar Tubing (Note 1)	B	Applicable to components with extension cable/wires (i.e., Termination Type Codes: 01, 02, 03, 04, 05) Note: Tubing operating temperature range: -55°C to +175°C

NOTES:

1. See Paras. 1.7.2.1, 1.7.2.2, 1.7.2.3, 1.7.2.4, 1.7.2.5 and 1.9.3.

(c) **Extension Cable/Wires Nominal Total Length**

The required nominal total length of the extension cable/wires, TL, shall be expressed by the following codes. The unit quantity shall be millimetre (mm).

Nominal Total Length (TL) (mm) (Note 1)	Code	Remarks
N/A	0000	Applicable to components with Platinum leads only (i.e., Termination Type Code: 00)
25 to 99	00XX	Applicable to components with extension cable/wires (i.e., Termination Type Codes: 01, 02, 03, 04, 05)
100 to 999	0XXX	Applicable to components with extension cable/wires (i.e., Termination Type Codes: 01, 02, 03, 04, 05)
1000 to 9999	XXXX	Applicable to components with extension cable/wires (i.e., Termination Type Codes: 01, 02, 03, 04, 05)

NOTES:

1. See Para. 1.7.2.

1.4.2 Component Type Variants and Range of Components

Variant Number	Sensor Element Based on Type (Article Number)	Nominal R _Z (Ω) (at 0°C) (Note 1)	Sensor Element Only Operating Temperature Range T _{op} (°C) (Note 2)	Maximum Operating Current I _{OP} (mA) (Notes 3, 4)	Maximum Rated Current I _{MAX} (mA)	Termination Options
01	P0K1.232.7W (101410)	100	-50 to +150	1	4	See Note 5
02	P0K1.232.7W (101411)	100	-200 to +200	1	4	See Note 5
03	P0K2.232.7W (150026)	200	-50 to +150	0.7	2.8	See Note 5
04	P0K2.232.7W (101412)	200	-200 to +200	0.7	2.8	See Note 5
05	P0K5.232.7W (101413)	500	-50 to +150	0.45	1.8	See Note 5
06	P0K5.232.7W (101414)	500	-200 to +200	0.45	1.8	See Note 5
07	P1K0.232.7W (101415)	1000	-50 to +150	0.3	1.3	See Note 5
08	P1K0.232.7W (101416)	1000	-200 to +200	0.3	1.3	See Note 5
09	P2K0.232.7W (101417)	2000	-50 to +150	0.2	0.9	See Note 5
10	P2K0.232.7W (101418)	2000	-200 to +200	0.2	0.9	See Note 5

RESISTANCE vs. TEMPERATURE LIMITS

Variant Number		R _Z (Ω) Over T _{op} (Notes 1, 2, 4)							
		-200°C	-100°C	-50°C	0°C	+50°C	+100°C	+150°C	+200°C
01	Min	-	-	80.087	99.882	119.185	138.202	156.932	-
	Max	-	-	80.524	100.117	119.608	138.808	157.717	-
02	Min	17.957	59.931	80.087	99.882	119.185	138.202	156.932	175.377
	Max	19.081	60.58	80.524	100.117	119.608	138.808	157.717	176.333
03	Min	-	-	160.174	199.764	238.37	276.404	313.864	-
	Max	-	-	161.048	200.234	239.216	277.616	315.434	-
04	Min	35	119.86	160.174	199.764	238.37	276.404	313.864	350.754
	Max	38.162	121.168	161.048	200.234	239.216	277.616	315.434	352.666
05	Min	-	-	400.435	499.41	595.925	691.01	784.66	-
	Max	-	-	402.62	500.585	598.04	694.04	788.585	-
06	Min	89.785	299.655	400.435	499.41	595.925	691.01	784.66	876.885
	Max	95.405	302.93	402.62	500.585	598.04	694.04	788.585	881.665
07	Min	-	-	800.87	998.82	1191.85	1382.02	1569.32	-
	Max	-	-	805.24	1001.17	1196.08	1388.08	1577.17	-
08	Min	179.571	599.315	800.87	998.82	1191.85	1382.02	1569.32	1753.77
	Max	190.811	605.86	805.24	1001.17	1196.08	1388.08	1577.17	1763.33
09	Min	-	-	1601.74	1997.64	2383.7	2764.04	3138.64	-
	Max	-	-	1610.48	2002.34	2392.16	2776.16	3154.34	-
10	Min	359.143	1198.62	1601.74	1997.64	2383.7	2764.04	3138.64	3507.54
	Max	381.623	1211.61	1610.48	2002.34	2392.16	2776.16	3154.34	3526.66

NOTES:

1. Zero Power Resistance, R_Z, excludes the resistance of any extension cable/wires.
2. Operating temperature range of the sensor element with platinum leads only. For sensors with extension cable/wires, operating temperature range is limited by the selected termination type (i.e., the applicable heat-shrink tubing type); see Para. 1.5.

3. Operating current is limited by self-heating. Mounting details have a major influence on self-heating.
4. For test purposes, when zero power is dissipated (i.e., $\leq I_{OP}$) and the ambient temperature is held as specified and measured with tolerance $\pm 0.01^\circ\text{C}$, the value is referred to as R_Z (Zero Power Resistance).
5. The following termination types are available for each Variant; see Paras. 1.4.1.1(a) and 1.7:
 - Platinum leads only (no extension cable/wires)
 - Twisted 2-core extension cable (with no shield) with length specified by the Orderer, welded to the platinum leads, with a choice of heat-shrink tubing over the welding area.
 - Twisted 4-core extension cable (with no shield) with length specified by the Orderer, welded to the platinum leads, with a choice of heat-shrink tubing over the welding area.
 - Twisted 2-core extension cable with shield and jacket with length specified by the Orderer, welded to the platinum leads, with a choice of heat-shrink tubing over the welding area.
 - Twisted 4-core extension cable with shield and jacket with length specified by the Orderer, welded to the platinum leads, with a choice of heat-shrink tubing over the welding area.
 - 2-wire extension (single extension wires) with length specified by the Orderer, welded to the platinum leads, with a choice of heat-shrink tubing over the welding area

1.5 MAXIMUM RATINGS

The maximum ratings shall not be exceeded at any time during use or storage.

Maximum ratings shall only be exceeded during testing to the extent specified in this specification and when stipulated in Test Methods and Procedures of the ESCC Generic Specification.

Characteristics	Symbols	Maximum Ratings	Units	Remarks
Maximum Rated Current	I_{MAX}	See Para. 1.4.2	mA	
Power Dissipation	P_D	20	mW	
Operating Temperature Range Variants 01 to 10 with Platinum leads only	T_{op}	See Para. 1.4.2	°C	
Variants 01, 03, 05, 07, 09 with Extension cable/wires and TFE-R Tubing		-50 to +150		Note 1
Variants 01, 03, 05, 07, 09 with Extension cable/wires and Kynar Tubing		-50 to +150		Note 2
Variants 02, 04, 06, 08, 10 with Extension cable/wires and TFE-R Tubing		-67 to +200		Note 1
Variants 02, 04, 06, 08, 10 with Extension cable/wires and Kynar Tubing		-55 to +175		Note 2
Storage Temperature Range Variants 01 to 10 with Platinum leads only	T_{stg}	-200 to +200	°C	
Variants 01, 03, 05, 07, 09 with Extension cable/wires and TFE-R Tubing		-67 to +200		Note 1
Variants 01, 03, 05, 07, 09 with Extension cable/wires and Kynar Tubing		-55 to +175		Note 2
Variants 02, 04, 06, 08, 10 with Extension cable/wires and TFE-R Tubing		-67 to +200		Note 1
Variants 02, 04, 06, 08, 10 with Extension cable/wires and Kynar Tubing		-55 to +175		Note 2

NOTES:

- For components with TFE-R Tubing, a short-term application of air flow with a temperature of $\leq +400^{\circ}C$ is permitted during the heat-shrink process.
- For components with Kynar Tubing, a short-term application of air flow with a temperature of $\leq +250^{\circ}C$ is permitted during the heat-shrink process

1.6 HANDLING PRECAUTIONS

These components are susceptible to damage by electrostatic discharge. Therefore, suitable precautions shall be employed for protection during all phases of manufacture, testing, shipment and any handling.

These components are categorised as Class 2 per ESCC Basic Specification No. [23800](#) with a Minimum Critical Path Failure Voltage of 2000 Volts.

1.7 PHYSICAL DIMENSIONS

1.7.1 Components with Platinum Leads Only – Termination Type Code 00

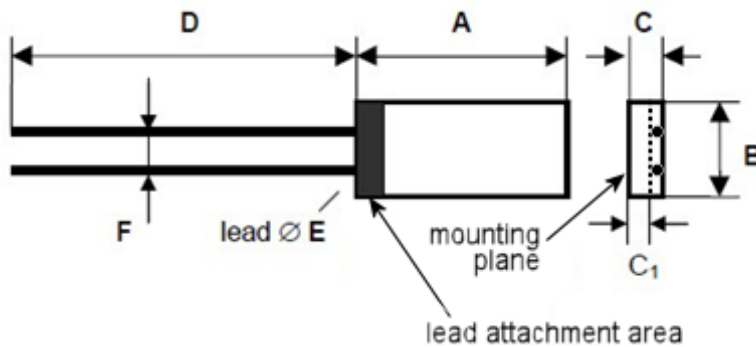

Symbol	Dimensions (mm)		Remarks
	Min	Max	
A	2.1	2.4	
B	1.8	2.2	
C	0.9	1.3	total thickness of the lead attachment area
C ₁	0.55	0.85	substrate thickness excluding the lead attachment area
D	9	10.7	
ØE	0.18	0.22	lead diameter
F	0.75	1.25	

1.7.2 Components with Extension Cable/Wires – Termination Type Codes 01, 02, 03, 04, 05

The dimensions of components with extension cable/wires are specified in Paras. 1.7.2.1 to 1.7.2.5.

The extension cable/wires actual total length, J, for each termination type shall be as follows:

Symbol	Dimensions (mm) (Note 1)	
	Min	Max
J	TL -0%	TL +10%

NOTES:

- Where $25\text{mm} \leq \text{TL} \leq 9999\text{mm}$, as required (TL is the nominal total length of the extension cable/wires; see Para. 1.4.1.1(c)).

1.7.2.1 Components with Twisted 2-Core Extension Cable (No Shield) – Termination Type Code 01

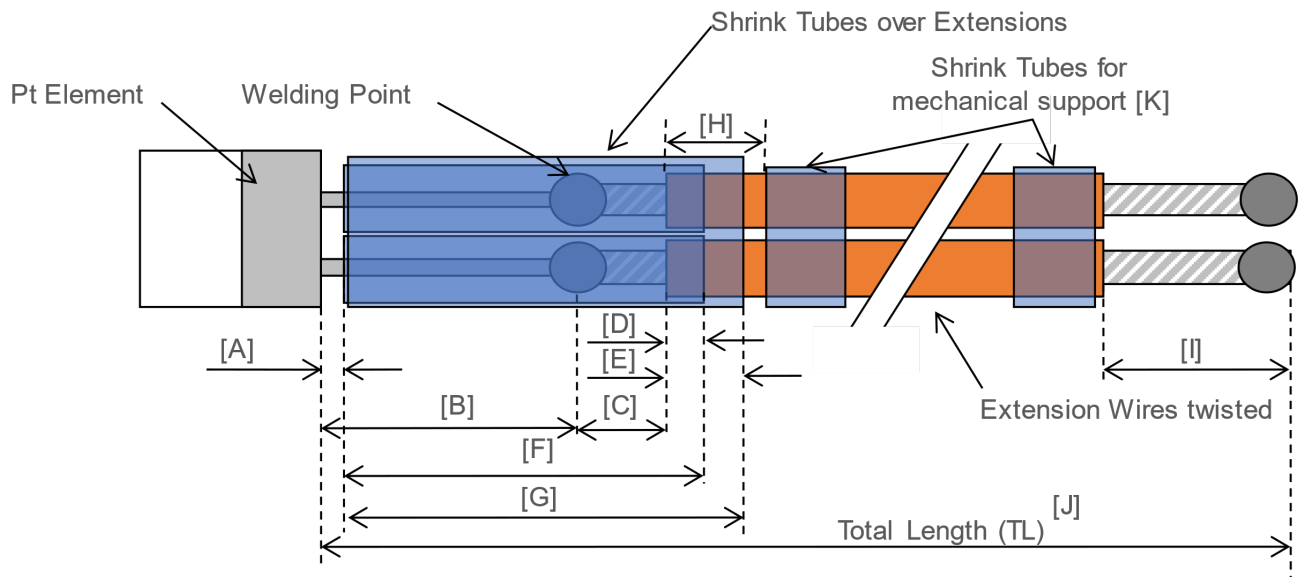

Symbol	Dimensions (mm)		Remarks
	Min	Max	
A	0	2	
B	4	6	Typical
C	2	4	Typical
D	0	10	Typical
E	2	14	
F	10	14	Typical
G	12	18	Typical
H	15	25	Typical
I	4	6	Typical
J	TL -0%	TL +10%	TL = Nominal Total length of the extension cable; see Para. 1.7.2
K	7	13	Typical

NOTES:

1. Sensor element dimensions in accordance with Para. 1.7.1, and extension cable dimensions per [390101910B](#) in accordance with ESCC Detail Specification No. [3901/019](#) (and Para. 1.7.2 herein).
2. The position of the heat-shrink tubing shall not move during use.
3. Typical dimensions need not be measured during Dimension Check in accordance with the ESCC Generic Specification.

1.7.2.2 Components with Twisted 4-Core Extension Cable (No Shield) – Termination Type Code 02

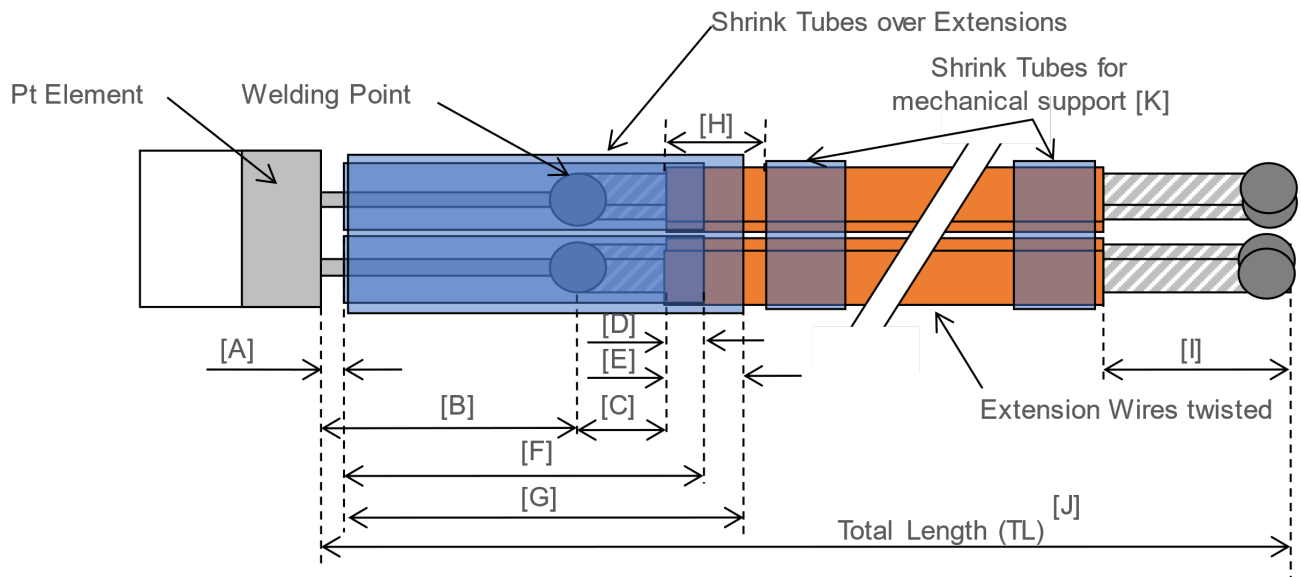

Symbol	Dimensions (mm)		Remarks
	Min	Max	
A	0	2	
B	4	6	Typical
C	2	4	Typical
D	0	10	Typical
E	2	14	
F	10	14	Typical
G	12	18	Typical
H	15	25	Typical
I	4	6	Typical
J	TL -0%	TL +10%	TL = Nominal Total length of the extension cable; see Para. 1.7.2
K	7	13	Typical

NOTES:

1. Sensor element dimensions in accordance with Para. 1.7.1, and extension cable dimensions per [390101926B](#) in accordance with ESCC Detail Specification No. [3901/019](#) (and Para. 1.7.2 herein).
2. The position of the heat-shrink tubing shall not move during use.
3. Typical dimensions need not be measured during Dimension Check in accordance with the ESCC Generic Specification.

1.7.2.3 Components with Twisted 2-Core Extension Cable with Shield and Jacket – Termination Type Code 03

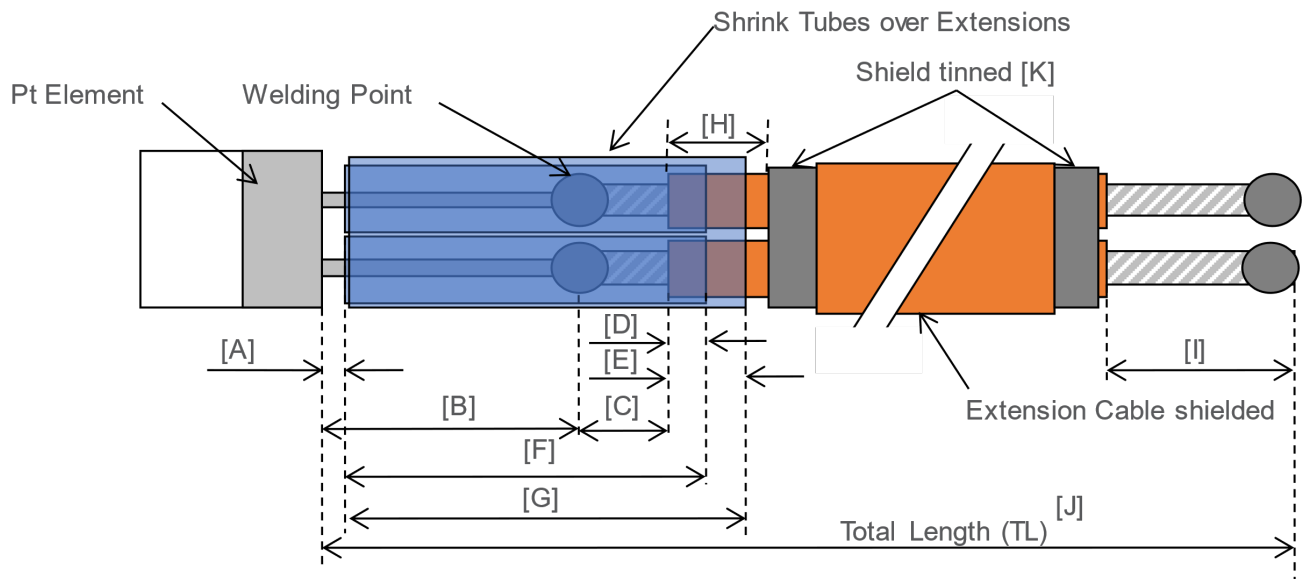

Symbol	Dimensions (mm)		Remarks
	Min	Max	
A	0	2	
B	4	6	Typical
C	2	4	Typical
D	0	10	Typical
E	2	14	
F	10	14	Typical
G	12	18	Typical
H	15	25	Typical
I	4	6	Typical
J	TL -0%	TL +10%	TL = Nominal Total length of the extension cable; see Para. 1.7.2
K	3	7	Typical

NOTES:

1. Sensor element dimensions in accordance with Para. 1.7.1, and extension cable dimensions per [390101957B](#) in accordance with ESCC Detail Specification No. [3901/019](#) (and Para. 1.7.2 herein).
2. The position of the heat-shrink tubing shall not move during use.
3. Typical dimensions need not be measured during Dimension Check in accordance with the ESCC Generic Specification.

1.7.2.4 Components with Twisted 4-Core Extension Cable with Shield and Jacket – Termination Type Code 04

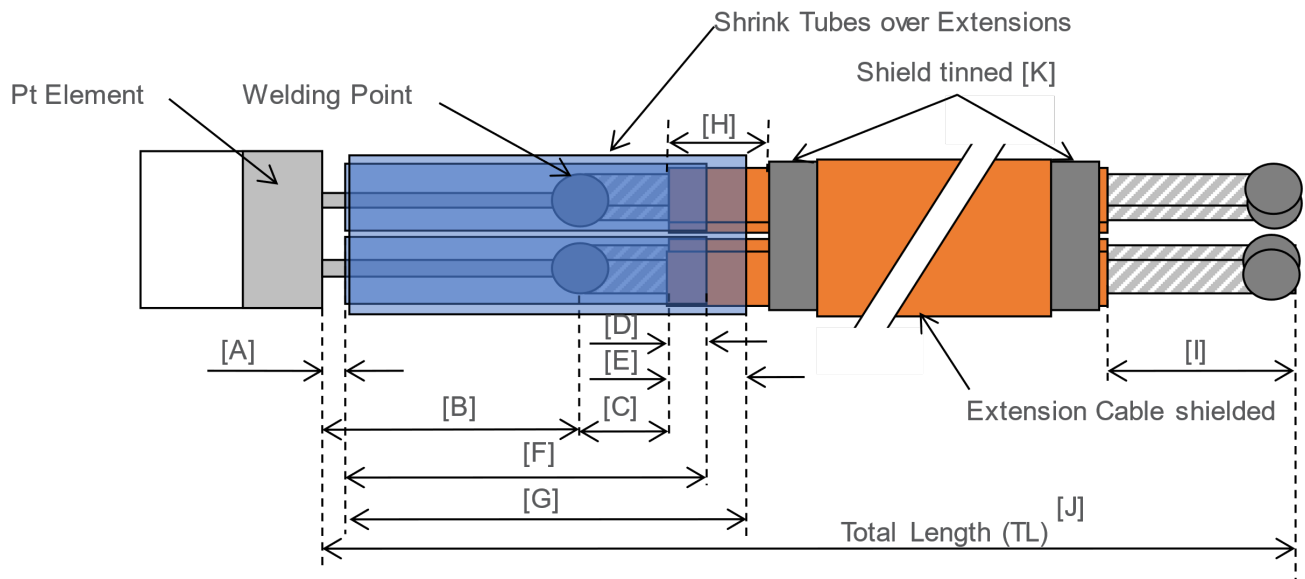

Symbol	Dimensions (mm)		Remarks
	Min	Max	
A	0	2	
B	4	6	Typical
C	2	4	Typical
D	0	10	Typical
E	2	14	
F	10	14	Typical
G	12	18	Typical
H	15	25	Typical
I	4	6	Typical
J	TL -0%	TL +10%	TL = Nominal Total length of the extension cable; see Para. 1.7.2
K	3	7	Typical

NOTES:

1. Sensor element dimensions in accordance with Para. 1.7.1, and extension cable dimensions per [390101973B](#) in accordance with ESCC Detail Specification No. [3901/019](#) (and Para. 1.7.2 herein).
2. The position of the heat-shrink tubing shall not move during use.
3. Typical dimensions need not be measured during Dimension Check in accordance with the ESCC Generic Specification.

1.7.2.5 Components with 2-Wire Extension – Termination Type Code 05

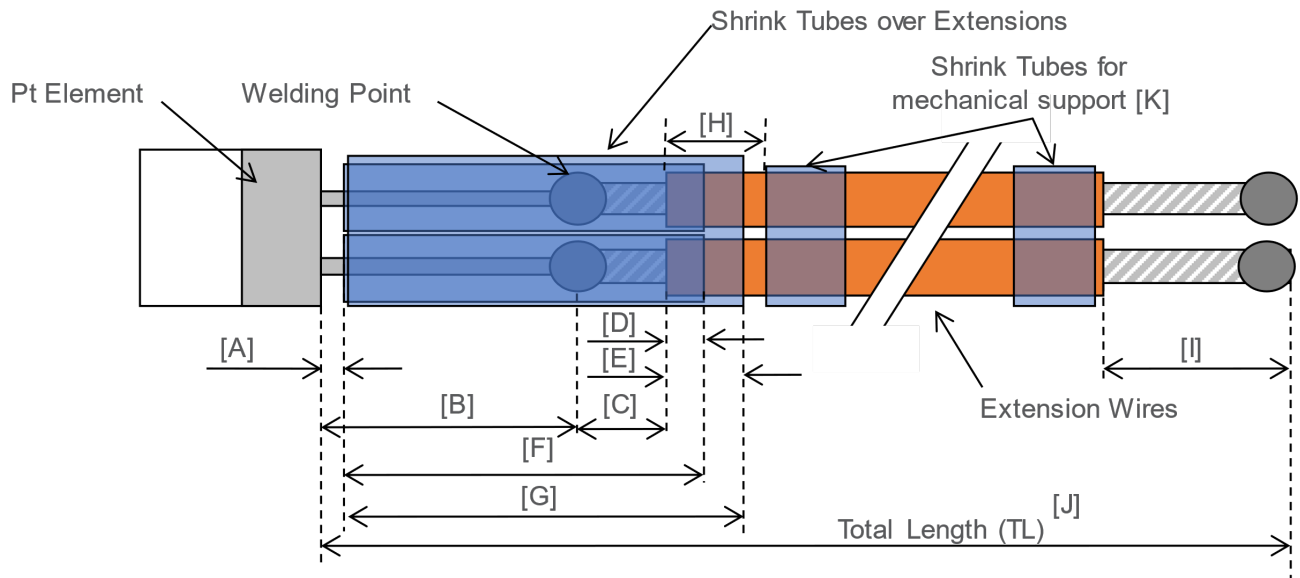

Symbol	Dimensions (mm)		Remarks
	Min	Max	
A	0	2	
B	4	6	Typical
C	2	4	Typical
D	0	10	Typical
E	2	14	
F	10	14	Typical
G	12	18	Typical
H	15	25	Typical
I	4	6	Typical
J	TL -0%	TL +10%	TL = Nominal Total length of the extension cable; see Para. 1.7.2
K	7	13	Typical

NOTES:

1. Sensor element dimensions in accordance with Para. 1.7.1, and extension wire dimensions per [390101902B](#) in accordance with ESCC Detail Specification No. [3901/019](#) (and Para. 1.7.2 herein).
2. The position of the heat-shrink tubing shall not move during use.
3. Typical dimensions need not be measured during Dimension Check in accordance with the ESCC Generic Specification.

1.8 FUNCTIONAL DIAGRAM

Components with Termination Type Codes 00, 01, 03, 05

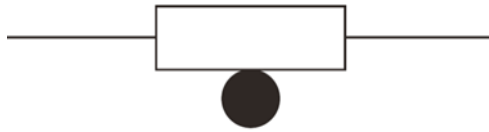

Components with Termination Type Codes 02, 04

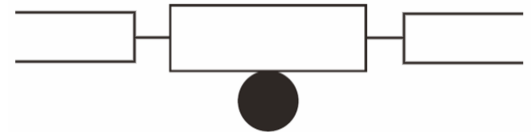

1.9 MATERIALS AND FINISHES

1.9.1 Body

Thin film Platinum printed on an Al₂O₃ substrate, covered with a transparent, glass passivation layer. The area of lead attachment on the substrate is also covered with a transparent, glass passivation layer.

1.9.2 Lead Material and Finish

1.9.2.1 Platinum Sensor Leads

Platinum wire.

1.9.2.2 Extension Cable/Wires

For components with termination type codes 01, 02, 03, 04, 05, extension cables/wires are welded to the cropped platinum leads of the sensor element. The exposed end of each core of the extension cable/wires shall be fused into a ball shape.

The materials of the extension cable/wires shall be as specified in ESCC Detail Specification No. [3901/019](#), as applicable.

For components with termination type codes 03, 04, each exposed area of cable shield shall be tinned using Sn62Pb36Ag2 solder (see Paras. 1.7.2.3 and 1.7.2.4).

1.9.3 Heat-shrink Tubing

For components with termination type codes 01, 02, 03, 04, 05, two layers of heat-shrink tubing shall cover the welding area as shown in Paras. 1.7.2.1, 1.7.2.2, 1.7.2.3, 1.7.2.4, 1.7.2.5; one layer covering each weld and a second layer covering both welds.

In addition, for components with termination type codes 01, 02, 05, a single layer of heat-shrink tubing is used around each end of the extension cable/wires for mechanical support; see Paras. 1.7.2.1, 1.7.2.2, 1.7.2.5.

The heat-shrink tubing material shall be as follows, as applicable:

Heat-shrink Tubing Type (See Para. 1.4.1.1(b))	Material	Colour
TFE-R (Code A)	Polytetrafluoroethylene	Transparent
Kynar (Code B)	Polyvinylidene fluoride	Transparent

1.10 WEIGHT

The sensor total maximum weight is calculated from the individual maximum weights of the various piece parts, as applicable, as follows:

- Sensor element: 350mg maximum.
- Extension Cable/Wires: as specified in ESCC Detail Specification No. [3901/019](#).
- Heat-shrink Tubing: 270mg maximum (total).

2 REQUIREMENTS

2.1 GENERAL

The complete requirements for procurement of the components specified herein are as stated in this specification and the ESCC Generic Specification. Permitted deviations from the Generic Specification, applicable to this specification only, are listed below.

Permitted deviations from the Generic Specification and this Detail Specification, formally agreed with specific Manufacturers on the basis that the alternative requirements are equivalent to the ESCC requirement and do not affect the component's reliability, are listed in the appendices attached to this specification.

2.1.1 Deviations from the Generic Specification

2.1.1.1 *Deviations from Special In-Process Controls – Chart F2*

- (a) Pre-Encapsulation (internal Visual) Inspection: shall not be performed.

2.1.1.2 *Deviations from Screening Tests – Chart F3*

- (a) Radiographic Inspection: shall not be performed.

- (b) Extension Cable/Wires Attachment:

Only for components with termination type codes 01, 02, 03, 04, 05.

On completion of Screening of the lot of components with termination type code 00, the required quantity shall be subjected to attachment of the extension cable/wires, and subsequent testing as follows, as a minimum:

1. Extension cable/wire shall be welded to the sensor leads in accordance with the PID (including sensor leads cropping, and heat-shrink tubing application and shrinking).
The sensors and the lead welds shall be visually inspected after welding both prior to and after application of the heat-shrink tubing (see note below). There shall be no evidence of damage. The lead welds shall be free of contamination, pits, holes or voids.
2. A non-destructive sample of 3 sensors with extension cable/wires shall be subjected to Dimension Check in accordance with the Generic Specification. No failures are allowed.
3. 100% of the sensors with extension cable/wires shall be subjected to High and Low Temperatures Electrical Measurements as specified in Para. 2.5.2. No failures are allowed. All values obtained shall be recorded against serial numbers.

NOTE: If stipulated in the Purchase Order, the Orderer may perform a source inspection at the Manufacturer's facility after the attachment of the extension cable/wires, prior to application of the heat-shrink tubing, in order to perform a visual inspection of the lead welds. Details of the required period of notification for this inspection shall be as stipulated in the Purchase Order.

2.1.1.3 *Deviations from Qualification and Periodic Tests - Chart F4*

- (a) Shock (Specified Pulse): For components with termination type code 00: shall not be performed.
- (b) Vibration: For components with termination type code 00: shall not be performed.
- (c) Resistance to Soldering Heat: shall not be performed.
- (d) Dissipation Constant: shall not be performed.
- (e) Thermal Time Constant: shall not be performed.
- (f) Solderability: shall not be performed.
- (g) Short Time Load: E_{TH} and I_{TH} shall be as specified in Para. 2.7 in the Detail Specification. Zero Power Resistance shall be measured before and after the test and Change in Zero Power Resistance shall be calculated; the limits specified in Para. 2.7 in the Detail Specification shall apply.

2.2 MARKING

The marking shall be in accordance with the requirements of ESCC Basic Specification No. [21700](#) and as follows.

The information to be marked on the component or the primary package shall be:

- (a) The ESCC Qualified Component Symbol (for ESCC qualified components only).
- (b) The ESCC Component Number (see Para. 1.4.1).
- (c) Traceability information.
- (d) Sensitivity to Electrostatic Discharge Symbol.

2.3 THERMAL SHOCK

Thermal Shock shall be performed as specified in the ESCC Generic Specification. The test conditions shall be as follows:

- For components with termination type code 00: Condition C with an exposure time of 2 minutes at each temperature extreme.
- For components with termination type codes 01, 02, 03, 04, 05: Condition C with an exposure time of 10 minutes at each temperature extreme, with the exception that the temperature extremes shall be the minimum and maximum storage temperature ratings as specified in Para. 1.5 herein.

2.4 TERMINAL STRENGTH

The test conditions for Terminal Strength, tested as specified in the ESCC Generic Specification, shall be as follows:

- Test Condition: A
- Method of Holding: The component body shall be glued to the test fixture.
- Applied Force:
 - For components with termination type code 00: 2 (+0.5 -0)N. The force shall be applied gradually to both terminals together and then maintained for a period of 5 seconds minimum.
 - For components with termination type codes 01, 02, 03, 04, 05: 2 (+0.5 -0)N. The force shall be applied gradually to the extension cable/wires and then maintained for a period of 5 seconds minimum.

2.5 ELECTRICAL MEASUREMENTS AT ROOM, HIGH AND LOW TEMPERATURES

Electrical measurements shall be performed at room, high and low temperatures.

2.5.1 Room Temperature Electrical Measurements

Unless otherwise specified, the measurements shall be performed at $T_{amb} = +22 \pm 3^{\circ}C$.

Characteristics	Symbols	Test Method and Conditions	Limits		Units
			Min	Max	
Zero Power Resistance at 0°C	R _Z	ESCC No. 4006, Note 1	Note 2		
Insulation Resistance	R _I	ESCC No. 4006, Note 3	100	-	MΩ

NOTES:

1. Zero Power Resistance shall be measured at $T_{amb} = +25 \pm 0.01^{\circ}C$ and $+85 \pm 0.01^{\circ}C$ with I_{OP} test conditions as specified in Para. 1.4.2. The resistance value at 0°C shall be calculated using the measured values and the following equation:

$$R_0 = R_T \div (1 + AT + BT^2)$$

Where:

- R₀ : calculated Zero Power Resistance at 0°C
- R_T : measured Zero Power Resistance at $T_{amb} = T$ (in °C)
- A = 3.9156×10^{-3}
- B = -6.4413×10^{-7}

All measurements and calculations shall be recorded against serial number.

For components with termination type codes 01, 03, 05, the resistance of the extension cable/wires shall be measured and subtracted from the measurements when calculating Zero Power Resistance.

2. See Para. 1.4.2 for R_Z limits.
3. The measurements shall be performed on a sample of 5 components with 0 failures permitted. In the event of any failure a 100% inspection may be performed.

2.5.2 High and Low Temperatures Electrical Measurements

Characteristics	Symbols	Test Method and Conditions	Limits		Units
			Min	Max	
Zero Power Resistance over T _{op}	R _Z	ESCC No. 4006, Note 1	Note 2		

NOTES:

1. Zero Power Resistance shall be measured at the following temperatures, each with an accuracy of $\pm 0.01^{\circ}C$, and with I_{OP} test conditions as specified in Para. 1.4.2:

- For Variants 01, 03, 05, 07, 09, $T_{amb} =$ (in °C):
0, +10, +20, +30, +40, +50, +60, +70, +80, +90, +100
- For Variants 02, 04, 06, 08, 10, $T_{amb} =$ (in °C):
-196, 0, +10, +20, +30, +40, +50, +60, +70, +80, +90, +100

The resistance value at each temperature specified in Para. 1.4.2 shall be calculated using the measured values and the equation given in Para. 2.5.1 Note 1. All measurements and calculations shall be recorded against serial number.

For components with termination type codes 01, 03, 05, the resistance of the extension cable/wires shall be measured and subtracted from the measurements when calculating Zero Power Resistance.

2. See Para. 1.4.2 for R_Z limits at each specified temperature.

2.6 PARAMETER DRIFT VALUES

The test methods and test conditions shall be as per the corresponding test defined in Para. 2.5.1 Room Temperature Electrical Measurements.

The drift values (Δ) shall not be exceeded for each characteristic. The corresponding absolute limit values for each characteristic shall not be exceeded.

Characteristics	Symbols	Limits		Units	
		Drift Value (Δ)	Absolute		
			Min		Max
Zero Power Resistance at 0°C	R _Z	±0.1%	See Para. 2.5.1		

2.7 INTERMEDIATE AND END-POINT ELECTRICAL MEASUREMENTS

The test methods and test conditions shall be as per the corresponding test defined in Para. 2.5.1 Room Temperature Electrical Measurements.

Test Reference per ESCC No. 4006	Characteristics	Symbols	Limits		Units
			Min	Max	
Moisture Resistance Initial Measurements Final Measurements	Zero Power Resistance at 0°C	R _Z	See Para. 2.5.1		
	Zero Power Resistance at 0°C Change in Zero Power Resistance at 0°C	R _Z $\Delta R_Z/R_Z$	-	±0.1	%
	Insulation Resistance	R _I	100	-	MΩ
Terminal Strength Initial Measurements (Note 1) Final Measurements	Zero Power Resistance at 0°C	R _Z	See Para. 2.5.1		
	Zero Power Resistance at 0°C Change in Zero Power Resistance at 0°C	R _Z $\Delta R_Z/R_Z$	-	±0.1	%
	Zero Power Resistance at 0°C Change in Zero Power Resistance at 0°C	R _Z $\Delta R_Z/R_Z$	-	±0.1	%
Short Time Load (P _D = Note 2) Initial Measurements (Note 1) Final Measurements	Zero Power Resistance at 0°C	R _Z	See Para. 2.5.1		
	Zero Power Resistance at 0°C Change in Zero Power Resistance at 0°C	R _Z $\Delta R_Z/R_Z$	-	±0.1	%
	Zero Power Resistance at 0°C Change in Zero Power Resistance at 0°C	R _Z $\Delta R_Z/R_Z$	-	±0.1	%
Low Temperature Storage Initial Measurements (Note 3) Final Measurements	Zero Power Resistance at 0°C	R _Z	See Para. 2.5.1		
	Zero Power Resistance at 0°C Change in Zero Power Resistance at 0°C	R _Z $\Delta R_Z/R_Z$	-	±0.1	%
	Zero Power Resistance at 0°C Change in Zero Power Resistance at 0°C	R _Z $\Delta R_Z/R_Z$	-	±0.1	%

Test Reference per ESCC No. 4006	Characteristics	Symbols	Limits		Units
			Min	Max	
Operating Life Initial Measurements (Note 3)	Zero Power Resistance at 0°C	R _Z	See Para. 2.5.1		
Intermediate Measurements (1000 hours)	Zero Power Resistance at 0°C	R _Z	See Para. 2.5.1		
	Change in Zero Power Resistance at 0°C	ΔR _Z /R _Z	-	±0.1	%
	Insulation Resistance	R _I	100	-	MΩ
Final Measurements (2000 hours)	Zero Power Resistance at 0°C	R _Z	See Para. 2.5.1		
	Change in Zero Power Resistance at 0°C	ΔR _Z /R _Z	-	±0.1	%
	Insulation Resistance	R _I	100	-	MΩ
High Temperature Storage Initial Measurements (Note 3)	Zero Power Resistance at 0°C	R _Z	See Para. 2.5.1		
Intermediate Measurements (1000 hours)	Zero Power Resistance at 0°C	R _Z	See Para. 2.5.1		
	Change in Zero Power Resistance at 0°C	ΔR _Z /R _Z	-	±0.1	%
Final Measurements (2000 hours)	Zero Power Resistance	R _Z	See Para. 2.5.1		
	Change in Zero Power Resistance at 0°C	ΔR _Z /R _Z	-	±0.1	%

NOTES:

1. Zero Power Resistance values recorded during Room Temperature Electrical Measurements during Chart F3 may be used as initial measurements.
2. E_{TH} and I_{TH} shall be adjusted to provide Maximum Rated Current as specified in Para. 1.5.
3. Zero Power Resistance values recorded during the final measurements of the previous test may be used as initial measurements.

2.8 BURN-IN CONDITIONS

Characteristics	Symbols	Test Conditions	Units
Ambient Temperature	T _{amb}	+150 ±10	°C
Test Current	I _{TEST}	2 x I _{OP} (Note 1)	mA

NOTES:

1. See Para. 1.4.2 for I_{OP} values.

2.9 OPERATING LIFE CONDITIONS

The conditions shall be as specified for Burn-in in Para. 2.8.

APPENDIX 'A'**AGREED DEVIATIONS FOR INNOVATIVE SENSOR TECHNOLOGY IST AG (CH)**

Items Affected	Description of Deviations
Para. 2.1.1, Deviations from the Generic Specification	Paras. 9.1.3(b), 9.1.4, 9.2(e), 9.6, Data Documentation: The relevant delivered data documentation for the components of the delivery lot, shall not be traceable to component serial number.
Para. 2.1.1.1, Deviations from Special In-Process Controls – Chart F2 Para. 2.1.1.2, Deviations from Screening Tests – Chart F3 Para. 2.1.1.3, Deviations from Qualification and Periodic Tests – Chart F4	Para. 8.5, External Visual Inspection: shall be performed in accordance with ESCC No. 2054000 , and the Manufacturer's visual inspection procedure as specified in the PID.
Para. 2.1.1.3, Deviations from Qualification and Periodic Tests – Chart F4	Para. 8.19, Permanence of Marking: shall not be performed.
Para. 2.2, Marking	The serial numbers of the components of the delivery lot shall not be marked on the components nor on the packaging.