



**CAPACITORS AND CAPACITOR FILTERS,  
FEEDTHROUGH**

**ESCC Generic Specification No. 3008**

Issue 4	June 2022
---------	-----------



### **LEGAL DISCLAIMER AND COPYRIGHT**

European Space Agency, Copyright © 2022. All rights reserved.

The European Space Agency disclaims any liability or responsibility, to any person or entity, with respect to any loss or damage caused, or alleged to be caused, directly or indirectly by the use and application of this ESCC publication.

This publication, without the prior permission of the European Space Agency and provided that it is not used for a commercial purpose, may be:

- copied in whole, in any medium, without alteration or modification.
- copied in part, in any medium, provided that the ESCC document identification, comprising the ESCC symbol, document number and document issue, is removed.

**DOCUMENTATION CHANGE NOTICE**

(Refer to <https://escies.org> for ESCC DCR content)

DCR No.	CHANGE DESCRIPTION
<a href="#">1232</a>	Specification upissued to incorporate changes per DCR.

**TABLE OF CONTENTS**

1	INTRODUCTION	8
1.1	SCOPE	8
1.2	APPLICABILITY	8
2	APPLICABLE DOCUMENTS	8
2.1	ESCC SPECIFICATIONS	8
2.2	OTHER (REFERENCE) DOCUMENTS	9
2.3	ORDER OF PRECEDENCE	9
3	TERMS, DEFINITIONS, ABBREVIATIONS, SYMBOLS AND UNITS	9
4	REQUIREMENTS	9
4.1	GENERAL	9
4.1.1	Specifications	10
4.1.2	Conditions and Methods of Test	10
4.1.3	Manufacturer's Responsibility for Performance of Tests and Inspections	10
4.1.4	Inspection Rights	10
4.1.5	Pre-Assembly Customer Source Inspection	10
4.2	QUALIFICATION AND QUALIFICATION MAINTENANCE REQUIREMENTS ON A MANUFACTURER	10
4.3	DELIVERABLE COMPONENTS	11
4.3.1	ESCC Qualified Components	11
4.3.2	ESCC Components	11
4.3.3	Lot Failure	11
4.4	MARKING	11
4.5	MATERIALS AND FINISHES	11
4.6	SUPPLEMENTARY COMPONENTS	12
5	PRODUCTION CONTROL	12
5.1	GENERAL	12
5.2	SPECIAL IN-PROCESS CONTROLS	12
5.2.1	Internal Visual Inspection	12
5.2.2	Dimension Check	12
5.2.3	Weight	12
5.2.4	Documentation	12
6	SCREENING TESTS	12
6.1	GENERAL	12
6.2	FAILURE CRITERIA	13
6.2.1	Environmental and Mechanical Test Failure	13
6.2.2	Parameter Drift Failure	13

6.2.3	Parameter Limit Failure	13
6.2.4	Other Failures	13
6.3	FAILED COMPONENTS	13
6.4	LOT FAILURE	13
6.4.1	Lot Failure during 100% Testing	13
6.4.2	Lot Failure during Sample Testing	14
6.5	DOCUMENTATION	14
7	QUALIFICATION, QUALIFICATION MAINTENANCE AND LOT VALIDATION TESTING	14
7.1	QUALIFICATION TESTING	14
7.1.1	General	14
7.1.2	Distribution within the Qualification Test Lot	14
7.2	QUALIFICATION WITHIN A TECHNOLOGY FLOW	15
7.3	QUALIFICATION MAINTENANCE (PERIODIC TESTING)	15
7.4	LOT VALIDATION TESTING	15
7.5	FAILURE CRITERIA	15
7.5.1	Environmental and Mechanical Test Failures	15
7.5.2	Electrical Failures	15
7.5.3	Other Failures	15
7.6	FAILED COMPONENTS	16
7.7	LOT FAILURE	16
7.8	QUALIFICATION, PERIODIC TESTING AND LOT VALIDATION TESTING SAMPLES	16
7.9	DOCUMENTATION	16
8	TEST METHODS AND PROCEDURES	16
8.1	INTERNAL VISUAL INSPECTION	16
8.2	EXTERNAL VISUAL INSPECTION AND DIMENSION CHECK	17
8.3	RAPID CHANGE OF TEMPERATURE	17
8.4	VIBRATION	17
8.4.1	Vibration during Qualification and Periodic Testing – Charts F4A and F4B	17
8.4.2	Vibration during Screening – Chart F3	18
8.5	ELECTRICAL MEASUREMENTS	18
8.5.1	General	18
8.5.1.1	Capacitance	18
8.5.1.2	Voltage Proof	19
8.5.1.3	Insulation Resistance	19
8.5.1.4	Insertion Loss	20
8.5.1.5	Voltage Drop	20

8.5.2	Parameter Drift Values	21
8.5.3	High and Low Temperatures Electrical Measurements	21
8.5.4	Room Temperature Electrical Measurements	21
8.5.5	Intermediate and End-Point Electrical Measurements	21
8.6	BURN-IN	21
8.7	RADIOGRAPHIC INSPECTION	21
8.8	SEAL (FINE AND GROSS LEAK)	21
8.8.1	Fine Leak	21
8.8.2	Gross Leak	21
8.9	TEMPERATURE RISE	22
8.10	OVERLOAD	22
8.11	LOW AIR PRESSURE	23
8.12	DAMP HEAT	23
8.13	RESISTANCE TO SOLDERING HEAT	24
8.14	SHOCK	24
8.15	IMMERSION	25
8.16	ACCELERATED DAMP HEAT	25
8.17	OPERATING LIFE	25
8.18	SOLDERABILITY	26
8.19	PERMANENCE OF MARKING	27
8.20	ROBUSTNESS OF TERMINATIONS	27
9	DATA DOCUMENTATION	28
9.1	GENERAL	28
9.1.1	Qualification and Qualification Maintenance	28
9.1.2	Component Procurement and Delivery	28
9.1.3	Additional Documentation	28
9.1.4	Data Retention/Data Access	28
9.2	COVER SHEET(S)	29
9.3	LIST OF EQUIPMENT USED	29
9.4	LIST OF TEST REFERENCES	29
9.5	SPECIAL IN-PROCESS CONTROLS DATA (CHART F2)	29
9.6	SCREENING TESTS DATA (CHART F3)	29
9.7	QUALIFICATION, PERIODIC TESTING AND LOT VALIDATION TESTING DATA (CHARTS F4A AND F4B)	29
9.7.1	Qualification Testing	29
9.7.2	Periodic Testing for Qualification Maintenance	30
9.7.3	Lot Validation Testing	30

9.8	FAILED COMPONENTS LIST AND FAILURE ANALYSIS REPORT	30
9.9	CERTIFICATE OF CONFORMITY	30
10	DELIVERY	30
11	PACKAGING AND DESPATCH	31
12	CHARTS	32
12.1	CHART F1 - GENERAL FLOW FOR PROCUREMENT	32
12.2	CHART F2 - PRODUCTION CONTROL	33
12.3	CHART F3 - SCREENING TESTS	34
12.4	CHART F4 - QUALIFICATION, PERIODIC TESTING AND LOT VALIDATION TESTING	35
12.4.1	Chart F4A - Qualification, Periodic Testing and Lot Validation Testing for Hermetically Sealed Components	35
12.4.2	Chart F4B - Qualification, Periodic Testing and Lot Validation Testing for Non-hermetically Sealed Components	36
12.4.3	Notes to Charts F4A and F4B	36

## 1 INTRODUCTION

### 1.1 SCOPE

This specification defines the general requirements for the qualification, qualification maintenance, procurement, and delivery of capacitors and capacitor filters, feedthrough, for space applications. This specification contains the appropriate inspection and test schedules and also specifies the data documentation requirements.

### 1.2 APPLICABILITY

This specification is primarily applicable to the granting of qualification approval to components qualified in accordance with one of the following ESCC methods:

- Qualification of Standard Components per ESCC Basic Specification No. [20100](#).
- Technology Flow Qualification per ESCC Basic Specification No. [25400](#).

It is also primarily applicable to the procurement of components so qualified.

This specification may also be applied to the procurement of unqualified components, recommendations for which are given in ESCC Basic Specification No. [23100](#).

## 2 APPLICABLE DOCUMENTS

The following documents form part of, and shall be read in conjunction with, this specification. The relevant issues shall be those in effect on the date of starting qualification or placing the Purchase Order.

### 2.1 ESCC SPECIFICATIONS

- No. [20100](#), Requirements for the Qualification of Standard Electronic Components for Space Application.
- No. [20400](#), Internal Visual Inspection.
- No. [20500](#), External Visual Inspection.
- No. [20600](#), Preservation, Packaging and Despatch of ESCC Components.
- No. [20900](#), Radiographic Inspection of Electronic Components.
- No. [21300](#), Terms, Definitions, Abbreviations, Symbols and Units.
- No. [21700](#), General Requirements for the Marking of ESCC Components.
- No. [22600](#), Requirements for the Evaluation of Standard Electronic Components for Space Application.
- No. [22800](#), ESCC Non-Conformance Control System.
- No. [23100](#), Recommendations on the use of the ESCC Specification System for the Evaluation and Procurement of Unqualified Components.
- No. [23500](#), Lead Materials and Finishes for Components for Space Application.
- No. [24400](#), Measurement of Insertion Loss for EMI Suppression Filters.
- No. [24600](#), Minimum Quality System Requirements.
- No. [24800](#), Resistance to Solvents of Marking, Materials and Finishes.
- No. [25400](#), Requirements for the Technology Flow Qualification of Electronic Components for Space Application.



For qualification and qualification maintenance or procurement of qualified components, with the exception of ESCC Basic Specifications Nos. [20100](#), [21700](#), [22800](#), [24600](#) and [25400](#), where Manufacturers' specifications are equivalent to, or more stringent than, the ESCC Basic Specifications listed above, they may be used in place of the latter, subject to the approval of the ESCC Executive.

Such replacements shall be clearly identified in the applicable Process Identification Document (PID).

For procurement of unqualified components, where Manufacturers' specifications are equivalent to or more stringent than the applicable ESCC Basic Specifications listed above, they may be used in place of the latter subject to the approval of the Orderer.

Such replacements may be listed in an appendix to the appropriate Detail Specification at the request of the Manufacturer or Orderer, subject to the approval of the ESCC Executive.

Unless otherwise stated herein, references within the text of this specification to "the Detail Specification" shall mean the relevant ESCC Detail Specification.

## 2.2 OTHER (REFERENCE) DOCUMENTS

- IEC Publication No. 60068 Part 2, Basic Environmental Testing Procedures.
- IEC Publication No. 60384 Part 1, Generic Specification for Fixed Capacitors for Use in Electronic Equipment.

## 2.3 ORDER OF PRECEDENCE

For the purpose of interpretation and in case of conflict with regard to documentation, the following order of precedence shall apply:

- (a) ESCC Detail Specification.
- (b) ESCC Generic Specification.
- (c) ESCC Basic Specification.
- (d) Other documents, if referenced herein.

## 3 TERMS, DEFINITIONS, ABBREVIATIONS, SYMBOLS AND UNITS

The terms, definitions, abbreviations, symbols and units specified in ESCC Basic Specification No. [21300](#) shall apply. In addition, the following shall apply:

- Hermetically sealed component: A component which, by design and/or construction, is sealed at each end by a hermetic seal and is therefore able to pass a seal test.
- Non-hermetically sealed component: A component whose ends are strengthened by seals which are not considered to be hermetic and is therefore unable to pass a seal test.

## 4 REQUIREMENTS

### 4.1 GENERAL

The requirements for the qualification of a component shall be in accordance with ESCC Basic Specification No. [20100](#).

The requirements for Technology Flow Qualification and listing of qualified component types shall be in accordance with ESCC Basic Specification No. [25400](#).

The test requirements for procurement of both qualified and unqualified components (see Chart F1) shall comprise:

- Special In-Process Controls.
- Screening Tests.
- Periodic Testing (for qualified components only).
- Lot Validation Testing if stipulated in the Purchase Order.

#### 4.1.1 Specifications

For qualification, qualification maintenance, procurement and delivery of components in conformity with this specification, the applicable specifications listed in Section 2 of this document shall apply in total unless otherwise specified herein or in the Detail Specification.

#### 4.1.2 Conditions and Methods of Test

The conditions and methods of test shall be in accordance with this specification, the ESCC Basic Specifications referenced herein and the Detail Specification.

#### 4.1.3 Manufacturer's Responsibility for Performance of Tests and Inspections

The Manufacturer shall be responsible for the performance of tests and inspections required by the applicable specifications. These tests and inspections shall be performed at the plant of the Manufacturer of the components unless it is agreed by the ESCC Executive (for qualification, qualification maintenance, or procurement of qualified components) or the Orderer (for procurement of unqualified components), to use an approved external facility.

#### 4.1.4 Inspection Rights

The ESCC Executive (for qualification, qualification maintenance, or procurement of qualified components) or the Orderer (for procurement of unqualified components, if stipulated in the Purchase Order) reserves the right to monitor any of the tests and inspections scheduled in the applicable specifications.

#### 4.1.5 Pre-Assembly Customer Source Inspection

If stipulated in the Purchase Order, the Orderer may perform a source inspection at the Manufacturer's facility prior to assembly (including, for example, performance of Internal Visual Inspection). Details of the inspections to be performed or witnessed and the required period of notification shall be as stipulated in the Purchase Order.

#### 4.2 QUALIFICATION AND QUALIFICATION MAINTENANCE REQUIREMENTS ON A MANUFACTURER

To obtain and maintain the qualification of a component, or family of components, a Manufacturer shall satisfy the requirements of ESCC Basic Specification No. [20100](#).

To obtain and maintain the qualification of a component produced using a qualified Technology Flow, a Manufacturer shall satisfy the requirements of ESCC Basic Specification No. [25400](#).

#### 4.3 DELIVERABLE COMPONENTS

##### 4.3.1 ESCC Qualified Components

Components delivered to this specification shall be processed and inspected in accordance with the relevant Process Identification Document (PID).

##### 4.3.2 ESCC Components

Each component, irrespective of qualification status, identified with an ESCC component number and delivered to this specification shall:

- be traceable to its production lot.
- have satisfactorily completed all the tests required by the relevant issues of the applicable specifications.
- be produced from lots that are considered by the Manufacturer to be capable of passing all applicable tests, and sequences of tests, that are defined in Charts F4A and F4B. The Manufacturer shall not knowingly supply components that cannot meet this requirement. In the event that, subsequent to delivery and prior to operational use, a component is found to be in a condition such that, demonstrably, it could not have passed these tests at the time of manufacture, this shall be grounds for rejection of the delivered lot.

##### 4.3.3 Lot Failure

Lot failure may occur during Screening Tests (Chart F3) or Qualification, Periodic Testing and Lot Validation Testing (Charts F4A and F4B).

Should such failure occur during qualification, qualification maintenance or procurement of qualified components the Manufacturer shall initiate the non-conformance procedure in accordance with ESCC Basic Specification No. [22800](#). The Manufacturer shall notify the Orderer and the ESCC Executive by any appropriate written means, within 5 working days, giving details of the number and mode of failure and the suspected cause. No further testing or analysis shall be performed on the failed components until so instructed by the ESCC Executive.

Should such failure occur during procurement of unqualified components the Manufacturer shall notify the Orderer by any appropriate written means within 5 working days, giving details of the number and mode of failure and the suspected cause. No further testing or analysis shall be performed on the failed components until so instructed by the orderer. The Orderer shall inform the Manufacturer within 5 working days of receipt of notification what action shall be taken.

#### 4.4 MARKING

All components procured and delivered to this specification shall be marked in accordance with ESCC Basic Specification No. [21700](#).

#### 4.5 MATERIALS AND FINISHES

Specific requirements for materials and finishes are specified in the Detail Specification. Where a definite material or finish is not specified a material or finish shall be used so as to ensure that the component meets the performance requirements of this specification and the Detail Specification. Acceptance or approval of any constituent material or finish does not guarantee acceptance of the finished product.

All materials and finishes of the components specified in the Detail Specification shall comply with the restrictions on materials specified in ESCC Basic Specification No. [22600](#).

#### 4.6 SUPPLEMENTARY COMPONENTS

Wherever possible, any supplementary components shall be obtained from ESCC qualified sources. The procurement controls for supplementary components shall be agreed with the ESCC Executive and form part of the PID.

### 5 PRODUCTION CONTROL

#### 5.1 GENERAL

Unless otherwise specified herein or in the Detail Specification, all lots of components used for qualification and qualification maintenance, Lot Validation Testing and for delivery shall be subject to tests and inspections in accordance with Chart F2 in the sequence shown.

Any components which do not meet these requirements shall be removed from the lot and at no future time be resubmitted to the requirements of this specification.

The applicable test requirements are detailed in the paragraphs referenced in Chart F2.

For qualified components the full production control provisions are defined in the PID.

#### 5.2 SPECIAL IN-PROCESS CONTROLS

##### 5.2.1 Internal Visual Inspection

Internal Visual Inspection shall be performed in accordance with Para. 8.1.

##### 5.2.2 Dimension Check

Dimension Check shall be performed in accordance with Para. 8.2 on 3 samples.

In the event of any failure a 100% Dimension Check shall be performed.

##### 5.2.3 Weight

The maximum weight of the component specified in the Detail Specification shall be guaranteed but not tested.

##### 5.2.4 Documentation

Documentation of Special In-Process Controls shall be in accordance with Para. 9.5.

### 6 SCREENING TESTS

#### 6.1 GENERAL

Unless otherwise specified herein or in the detail specification, all lots of components used for qualification and qualification maintenance, Lot Validation Testing, and for delivery, shall be subjected to tests and inspections in accordance with Chart F3 in the sequence shown.

All components shall be serialised prior to the tests and inspections.

Any components which do not meet these requirements shall be removed from the lot and at no future time be resubmitted to the requirements of this specification.

The applicable test methods and conditions are specified in the paragraphs referenced in Chart F3.

## 6.2 FAILURE CRITERIA

### 6.2.1 Environmental and Mechanical Test Failure

The following shall be counted as component failures:

Components which fail during tests for which the pass/fail criteria are inherent in the test method, i.e. Vibration, Radiographic Inspection, Seal (Fine and Gross Leak) and External Visual Inspection.

### 6.2.2 Parameter Drift Failure

The acceptable change limits are shown in Parameter Drift Values in the Detail Specification. A component shall be counted as a parameter drift failure if the changes during Burn-in are larger than the drift values ( $\Delta$ ) specified.

### 6.2.3 Parameter Limit Failure

A component shall be counted as a limit failure if one or more parameters exceed the limits shown in Room Temperature Electrical Measurements or High and Low Temperatures Electrical Measurements in the Detail Specification.

Any component which exhibits a limit failure prior to the submission to Burn-in shall be rejected and not counted when determining lot rejection.

### 6.2.4 Other Failures

A component shall be counted as a failure in any of the following cases:

- Visual failure.
- Mechanical failure.
- Handling failure.
- Lost component.

Any failure prior to the submission to Burn-in shall be rejected and not counted when determining lot rejection.

## 6.3 FAILED COMPONENTS

A component shall be considered as a failed component if it exhibits one or more of the failure modes described in Para. 6.2.

## 6.4 LOT FAILURE

In the case of lot failure, the Manufacturer shall act in accordance with Para. 4.3.3.

### 6.4.1 Lot Failure during 100% Testing

If the number of components failed on the basis of the failure criteria described in Para. 6.2 subsequent to Burn-in equals or exceeds 5% (rounded upwards to the nearest whole number) of the number of components submitted to burn-in and electrical measurements for electrical failures (Paras. 6.2.2 and 6.2.3) and/or 5% for other failures (Para. 6.2.4), the lot shall be considered as failed.

Components rejected for plating discolouration after burn-in shall not be considered for lot failure.

If a lot is composed of groups of components of one family defined in one ESCC Detail Specification, but separately identifiable for any reason, then the lot failure criteria shall apply separately to each identifiable group.

#### 6.4.2 Lot Failure during Sample Testing

A lot shall be considered as failed if the number of allowable failures during sample testing, as specified herein or in the Detail Specification, is exceeded.

Unless otherwise specified, if a lot failure occurs, a 100% testing may be performed but the cumulative percent defective shall not exceed that specified in Para. 6.4.1.

#### 6.5 DOCUMENTATION

Documentation of Screening Tests shall be in accordance with Para. 9.6.

### 7 QUALIFICATION, QUALIFICATION MAINTENANCE AND LOT VALIDATION TESTING

The requirements of this paragraph are applicable to the tests performed on components or test structures as part of qualification or qualification maintenance in accordance with either ESCC Basic Specification No. 20100 or 25400 as applicable. They are also applicable to Lot Validation Testing as part of the procurement of qualified or unqualified components.

#### 7.1 QUALIFICATION TESTING

##### 7.1.1 General

Qualification testing shall be in accordance with the requirements specified in Charts F4A and F4B. The tests of Charts F4A and F4B shall be performed on the specified sample chosen at random from components which have successfully passed the tests in Chart F3. This sample constitutes the Qualification Test Lot.

The Qualification Test Lot is divided into subgroups of tests and all components assigned to a subgroup shall be subjected to all of the tests in that subgroup, in the sequence shown. The applicable test requirements are detailed in the paragraphs referenced in Charts F4A and F4B.

The conditions governing qualification testing are specified in ESCC Basic Specification No. 20100.

##### 7.1.2 Distribution within the Qualification Test Lot

Where a Detail Specification covers a range, or series of components that are considered similar, then the Qualification Test Lot shall be comprised of test vehicles so selected that they adequately represent all of the various mechanical, structural and electrical peculiarities of that range or series.

In addition, the Qualification Test Lot test vehicles shall be selected in accordance with the following provisions:

- Components with the maximum and minimum rated voltage/current proposed for qualification shall be selected.
- For each voltage/current combination selected, the maximum capacitance and tightest tolerance shall be selected.

The test vehicles may be specified by, but in any case shall be agreed with, the ESCC Executive, prior to the commencement of qualification testing and the justification for the selection shall be declared in the qualification test report.

## 7.2 QUALIFICATION WITHIN A TECHNOLOGY FLOW

The qualification of a component produced using a qualified Technology Flow shall be in accordance with ESCC Basic Specification No. [25400](#).

## 7.3 QUALIFICATION MAINTENANCE (PERIODIC TESTING)

Qualification is maintained through periodic testing and the test requirements of Para. 7.1 shall apply. For each subgroup the sample size and the period between successive subgroup testing shall be as specified in Charts F4A and F4B. The conditions governing qualification maintenance are specified in ESCC Basic Specification No. [20100](#).

Qualification of a component, produced using a qualified Technology Flow, is maintained by maintenance of the Technology Flow Qualification itself in accordance with ESCC Basic Specification No. [25400](#).

## 7.4 LOT VALIDATION TESTING

For procurement of qualified components Lot Validation Testing is not required and shall only be performed if specifically stipulated in the Purchase Order.

For procurement of unqualified components the need for Lot Validation Testing shall be determined by the Orderer (ref. ESCC Basic Specification No. [23100](#)).

When Lot Validation Testing is required it shall consist of the performance of one or more of the tests or subgroup test sequences of Charts F4A and F4B. The testing to be performed and the sample size shall be as stipulated in the Purchase Order.

When procurement of more than one component type is involved from a family, range or series, the selection of representative samples shall also be stipulated in the Purchase Order.

## 7.5 FAILURE CRITERIA

The following criteria shall apply to Qualification, Periodic Testing and Lot Validation Testing.

### 7.5.1 Environmental and Mechanical Test Failures

The following shall be counted as component failures:

Components which fail during tests for which the pass/fail criteria are inherent in the test method, e.g. Seal (Fine and Gross Leak), Solderability, etc.

### 7.5.2 Electrical Failures

The following shall be counted as component failures:

- Components which fail one or more of the applicable limits at each of the relevant data points specified for environmental, mechanical and endurance testing in Intermediate and End-Point Electrical Measurements in the Detail Specification.

### 7.5.3 Other Failures

A component shall be counted as a failure in any of the following cases:

- Visual failure.
- Mechanical failure.
- Handling failure.

- Lost component.

#### 7.6 FAILED COMPONENTS

A component shall be considered as failed if it exhibits one or more of the failure modes detailed in Para. 7.5.

When requested by the ESCC Executive (for qualification, qualification maintenance or procurement of qualified components) or the Orderer (for procurement of qualified or unqualified components), failure analysis of failed components shall be performed under the responsibility of the Manufacturer and the results provided.

Failed components shall be retained at the Manufacturer's plant until the final disposition has been agreed and certified.

#### 7.7 LOT FAILURE

For Qualification Testing and Periodic Testing, the lot shall be considered as failed if one component in any subgroup of Charts F4A and F4B is a failed component based on the criteria specified in Para. 7.5.

For procurement, the lot shall be considered as failed if one component in any test specified for Lot Validation Testing is a failed component based on the criteria specified in Para. 7.5.

In the case of lot failure, the Manufacturer shall act in accordance with Para. 4.3.3.

#### 7.8 QUALIFICATION, PERIODIC TESTING AND LOT VALIDATION TESTING SAMPLES

All tests of Charts F4A and F4B are considered to be destructive and therefore components so tested shall not form part of the delivery lot.

#### 7.9 DOCUMENTATION

Documentation of Qualification, Periodic Testing and Lot Validation Testing shall be in accordance with Para. 9.7.

### 8 TEST METHODS AND PROCEDURES

If a Manufacturer elects to eliminate or modify a test method or procedure, the Manufacturer is still responsible for delivering components that meet all of the performance, quality and reliability requirements defined in this specification and the Detail Specification.

For a qualified component, documentation supporting the change shall be approved by the ESCC Executive and retained by the Manufacturer. It shall be copied, when requested, to the ESCC Executive. The change shall be specified in an appendix to the Detail Specification and in the PID.

For an unqualified component the change shall be approved by the Orderer. The change may be specified in an appendix to the Detail Specification at the request of the Manufacturer or Orderer, subject to the approval of the ESCC Executive.

#### 8.1 INTERNAL VISUAL INSPECTION

ESCC Basic Specification No. [20400](#).



## 8.2 EXTERNAL VISUAL INSPECTION AND DIMENSION CHECK

External Visual Inspection shall be performed in accordance with ESCC Basic Specification No. [20500](#).

Dimension Check shall be performed in accordance with ESCC Basic Specification No. [20500](#).

## 8.3 RAPID CHANGE OF TEMPERATURE

Components shall be subjected to Test Na of IEC Publication No. 60068-2-14. The following details shall apply:

- **Mounting**  
Components shall be mounted by their normal mounting means and, where applicable, to the torque rating defined in the Detail Specification.
- **Test Conditions for Screening Tests – Chart F3**
  - (a) Low temperature: minimum operating temperature rating as specified in the Detail Specification.
  - (b) High temperature: maximum operating temperature rating as specified in the Detail Specification.
  - (c) Number of cycles: 5.
  - (d) Exposure time (each cycle, each temperature): 30 minutes.
  - (e) Transition time: 1 minute.
- **Test Conditions for Qualification and Periodic Testing – Charts F4A and F4B**
  - (a) Low temperature: minimum storage temperature rating as specified in the Detail Specification.
  - (b) High temperature: maximum storage temperature rating as specified in the Detail Specification.
  - (c) Number of cycles: 10.
  - (d) Exposure time (each cycle, each temperature): 30 minutes.
  - (e) Transition time: 1 minute.
- **Data Points**  
On completion of testing, the components shall be subjected to standard atmospheric conditions for a recovery period of 24 ±2 hours.  
  
After recovery, the components shall be visually examined. There shall be no evidence of damage.

## 8.4 VIBRATION

### 8.4.1 Vibration during Qualification and Periodic Testing – Charts F4A and F4B

Components shall be subjected to Test Fc of IEC Publication No. 60068-2-6. The following details shall apply:

- **Test Conditions**
  - (a) **Frequency Range and Duration:** The entire frequency range of 10 to 2000Hz and return to 10Hz shall be traversed logarithmically in 20 minutes. This cycle shall be performed 6 times in each of three mutually perpendicular directions (total of 18 times), so that the motion shall be applied for a total period of approximately 6 hours.
  - (b) **Vibration amplitude:** 0.75mm double amplitude or 200m/s<sup>2</sup> (peak) whichever gives the lower acceleration.

- (c) Applied current: Rated current (for DC rated components where the centre terminal is a continuous conductor without internal joints, the current applied may be limited to that required for monitoring purposes).
  - (d) Applied voltage: 100% of rated voltage.
  - (e) Mounting: The components shall be mechanically connected to the vibration generator either directly or by means of a fixture. Mounting fixtures shall enable the components to be vibrated in 3 mutually perpendicular axes in turn, which should be so chosen that faults are most likely to be revealed. Components shall be mounted by their normal mounting means and, where applicable, to the torque rating defined in the Detail Specification. Additional restraining straps should be avoided. Unless otherwise specified, components not provided with specific means of mounting shall be clamped on both body and leads (leads shall be clamped at  $6 \pm 1$ mm from the body). Care should be taken to avoid pinching the leads. If external connections, necessary for measuring and supply purposes, are specified in the Detail Specification, they should add the minimum restraint and mass.
- Data Points  
During the last cycle in each direction, the components shall be monitored for intermittent short-circuits between the terminals and case, or open-circuits between terminals, of duration 0.1ms or longer.

On completion of testing, the components shall be visually examined. There shall be no evidence of damage. Insertion Loss shall be measured as specified in Intermediate and End-Point Electrical Measurements in the Detail Specification.

#### 8.4.2 Vibration during Screening – Chart F3

As Para. 8.4.1, except for the following details:

- The minimum frequency shall be 100Hz.
- The entire frequency range of 100 to 2000Hz and return to 100Hz shall be traversed once, logarithmically in 10 minutes, in the plane considered to be the most vulnerable.
- For components where the centre terminal is a continuous conductor without internal joints, monitoring of the components for open-circuits between terminals shall not be performed.

### 8.5 ELECTRICAL MEASUREMENTS

#### 8.5.1 General

Unless otherwise specified in the Detail Specification, the following electrical measurements and test methods apply.

##### 8.5.1.1 Capacitance

In accordance with IEC Publication No. 60384-1 clause 4.7. Unless otherwise specified, the following details shall apply:

- (a) Test frequency:  $1000 \pm 100$ Hz
- (b) Measuring voltage: 0.1 to 1.2Vrms

The accuracy of the measuring equipment shall be such that the error does not exceed:

- For absolute capacitance measurements: 10% of the rated capacitance tolerance.
- For measurement of variation in capacitance: 10% of the specified change in capacitance.

Temperature variation due to handling shall be avoided.

N.B.: following Voltage Proof or Insulation Resistance, the capacitance measurement may be delayed for a period of up to 24 hours.

**8.5.1.2 Voltage Proof**

In accordance with IEC Publication No. 60384-1 clause 4.6. Unless otherwise specified, the following details shall apply:

- (a) Measuring points: Between terminals connected together and the case.
- (b) Test voltage:  
 For DC rated components the test voltage shall be  $2.5 \times$  the rated DC voltage defined in the Detail Specification.  
 For AC rated components the test voltage shall be  $2.8 \times$  the rated rms AC voltage at the defined frequency.
- (c) Test voltage application time: 60 seconds between the test points.
- (d) Internal resistance of the voltage source  $R_S$  shall be such that  $R_S C_R < 1s$
- (e) Voltmeter resistance:  $\geq 20000\Omega/V$
- (f) Charging/discharging current:  $50\mu A/pF$  maximum for  $C \leq 1000pF$ ;  $50mA$  maximum for  $C > 1000pF$

There shall be no visible or electrical sign of breakdown or flash-over during the test period and, after completion of the test, the components shall be further visually examined for evidence of damage, arcing or breakdown.

**8.5.1.3 Insulation Resistance**

In accordance with IEC Publication No. 60384-1 clause 4.5. Unless otherwise specified, the following details shall apply:

- (a) Measurement accuracy: 10% from one-hundredth of the limit value to  $10^5 M\Omega$
- (b) Internal resistance of the voltage source  $R_S$  shall be such that  $R_S C_R < 1s$
- (c) Charging current:  $50\mu A/pF$  maximum for  $C \leq 1000pF$ ;  $50mA$  maximum for  $C > 1000pF$

Measurements shall be made carefully to prevent damage to the component seal. If components fail this test due to ambient relative humidity in excess of 50%, they may be re-tested at any relative humidity from 20 to 50%.

The correction factors to be applied to the insulation resistance measurements are shown below:

°C	Correction Factor	°C	Correction Factor
20	1.42	28	0.82
21	1.33	29	0.76
22	1.24	30	0.71
23	1.16	31	0.67
24	1.08	32	0.63
25	1	33	0.59
26	0.94	34	0.55
27	0.87	35	0.51

8.5.1.4 *Insertion Loss*

Insertion Loss shall be performed in accordance with ESCC Basic Specification No. 24400 and as follows:

- Measurement Accuracy
  - For zero load current measurements at room temperature:  $\leq \pm 3\text{dB}$
  - For rated current measurements at room temperature:  $\leq \pm 4\text{dB}$
- Requirements for High and Low Temperatures Electrical Measurements
 

The test circuit employed for Room Temperature Electrical Measurements may be used. To accommodate the temperature chamber cables of not more than 600mm length with PTFE or equivalent dielectric may be interposed between each buffer network and the component under test.
- Measurements during Screening and Periodic Testing for extension of qualification
 

Measurements shall be made at a minimum of three test frequencies which shall be defined in the Detail Specification. These frequencies shall be selected to include both the pass and stop bands. Unless otherwise specified in the Detail Specification, no load current shall be applied.
- Measurements during Qualification Testing and Periodic Testing for renewal of qualification after lapse
 

Measurements shall be made at a minimum of five test frequencies which shall be defined in the Detail Specification. These frequencies shall be selected to include both the pass and stop bands. Unless otherwise specified in the Detail Specification, all insertion loss measurements shall be made with a load current of zero and, during either Subgroup 1B or Subgroup 1C of Charts F4A and F4B, insertion loss measurements shall also be made at rated current.

8.5.1.5 *Voltage Drop*

Using a suitable test circuit, components shall be energised with the rated current as defined in the Detail Specification.

For AC rated components, true rms reading instruments shall be employed with the test circuit operating at the maximum rated frequency.

A measurement shall be made across the component's terminals and shall comply with the Maximum Rating specified in the Detail Specification.

EXAMPLE OF VOLTAGE DROP TEST CIRCUIT

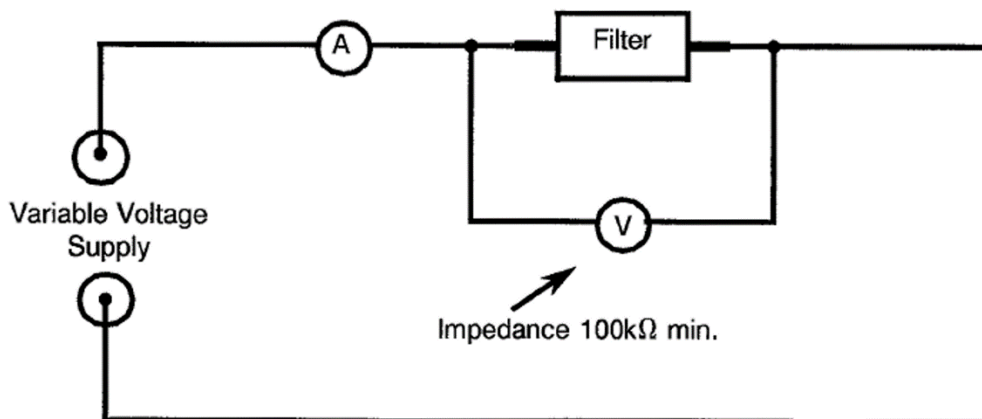

#### 8.5.2 Parameter Drift Values

At each of the relevant data points during Screening Tests, Parameter Drift Values shall be measured as specified in the Detail Specification. All values obtained shall be recorded against serial numbers and the parameter drift calculated.

#### 8.5.3 High and Low Temperatures Electrical Measurements

High and Low Temperatures Electrical Measurements shall be performed as specified in the Detail Specification. All values obtained shall be recorded against serial numbers. Unless otherwise specified measurements shall be performed on a sample of 5 components with 0 failures allowed. In the event of any failure a 100% inspection may be performed.

#### 8.5.4 Room Temperature Electrical Measurements

Room Temperature Electrical Measurements shall be performed as specified in the Detail Specification. All values obtained shall be recorded against serial numbers.

#### 8.5.5 Intermediate and End-Point Electrical Measurements

At each of the relevant data points during Qualification and Periodic Testing, Intermediate and End-Point Electrical Measurements shall be performed as specified in the Detail Specification. All values obtained shall be recorded against serial numbers and the parameter drift calculated, if specified.

#### 8.6 BURN-IN

Components shall be subjected to an endurance test in accordance with IEC Publication No. 60384-1 clause 4.23. The test conditions shall be as specified in Burn-in in the Detail Specification.

Unless otherwise specified, the burn-in duration shall be 168 hours minimum.

The insulation resistance of the components shall be measured on completion of the burn-in period and while the components are still at the specified burn-in test temperature. The applicable insulation resistance limits are specified in High and Low Temperatures Electrical Measurements in the Detail Specification.

#### 8.7 RADIOGRAPHIC INSPECTION

ESCC Basic Specification No. [20900](#).

#### 8.8 SEAL (FINE AND GROSS LEAK)

##### 8.8.1 Fine Leak

Components shall be subjected to Test Qk, Method 1, of IEC Publication No. 60068-2-17. The following details shall apply:

- (a) Severity: 1000 hours.
- (b) Immersion pressure:  $\leq 400\text{kPa}$ , unless otherwise specified in the Detail Specification.

##### 8.8.2 Gross Leak

Components shall be subjected to Test Qc, Method 2, of IEC Publication No. 60068-2-17. A suitable inert fluorocarbon liquid, at a temperature of  $+125 \pm 2^\circ\text{C}$ , shall be used.

There shall be no evidence of repetitive bubbling.

8.9 TEMPERATURE RISE

Temperature Rise is applicable to Qualification Testing, and to Periodic Testing for renewal of qualification after lapse.

Unless otherwise specified, the following details shall apply:

- **Mounting**

Components shall be suspended by their terminals during the test. They shall be separated from each other by a distance of not less than 25mm. During the test, radiant shields may be placed between units, so that overheating of one unit will not affect a nearby unit. Lead wires shall be of copper, 150mm long and of the size specified hereunder.

Rated Current of Filter (A)	Wire Size	
	AWG	Dia. (mm)
Up to 3	24	0.64
3+ to 5	22	0.85
5+ to 11	20	1.04
11+ to 16	18	1.29
16+ to 22	16	1.53
22+ to 32	14	1.87

- **Test Conditions**

- (a) Test temperature: +22 ±3°C, without forced-air ventilation or any means of component cooling.
- (b) Applied current: rated DC current as defined in the Detail Specification.

- **Measurements**

After thermal stability has been reached and while the component is still energised, the maximum hot-spot on the component case shall be determined by the use of thermocouples.

The temperature rise ( $\Delta T$ ) shall be calculated by the following formula:  $\Delta T = T - t$

where:

- T = Temperature in °C of the component under test.
- t = Ambient temperature in °C.

- **Limit**

Unless otherwise specified in the Detail Specification, the temperature rise shall not exceed 25°C.

8.10 OVERLOAD

Overload is applicable to Qualification Testing, and to Periodic Testing for renewal of qualification after lapse.

Unless otherwise specified, the following details shall apply:

- **Mounting**

Components shall be suspended by their terminals in free air at an ambient temperature of +20°C minimum.

- **Test Conditions**

- (a) Applied current: 140% of rated DC current.

(b) Duration: 15 minutes minimum.

- Data Points

After the application of the overload current the components shall be allowed to cool to room temperature.

The components shall be visually examined. There shall be no evidence of damage. Insulation Resistance and Voltage Drop shall be measured as specified in Intermediate and End Point Electrical Measurements in the Detail Specification.

#### 8.11 LOW AIR PRESSURE

Components shall be subjected to Test M of IEC Publication No. 60068-2-13. Unless otherwise specified, the following details shall apply:

- Test Conditions

(a) Pressure: 4kPa

(b) Duration: 1 hour

(c) Temperature: +15 to +35°C

(d) Applied Voltage (Voltage Proof): 125% of the rated voltage, specified in the Detail Specification, applied during the last 5 minutes of the 1 hour period at low pressure.

- Data Points

During and after the test, the components shall be monitored and there shall be no sign of permanent breakdown, flashover, harmful deformation of the case or seepage of impregnant.

#### 8.12 DAMP HEAT

Components shall be subjected to a Damp Heat test as follows:

Components shall be mounted by their normal mounting means and, where applicable, to the torque rating defined in the Detail Specification. The components shall be placed in the test chamber and maintained, for a period of 168 hours, under the following conditions:

- Humidity: 85%

- Temperature: +85 (+2 -0)°C

The voltage to be applied to components with multilayer (discoidal) ceramic capacitor(s) shall be 1.5V (DC), with a series resistor not exceeding 20kΩ.

The voltage to be applied to components with a tubular ceramic capacitor shall be the rated DC voltage defined in the Detail Specification.

- Data Points

On completion of testing, the components shall be subjected to standard atmospheric conditions for recovery for a period of 4 hours.

After recovery, the components shall be visually examined. There shall be no evidence of cracking or separation of the encapsulant from the case or inner conductors. Insulation Resistance shall be measured, using the voltage applied during the test, as specified in Intermediate and End-Point Electrical Measurements in the Detail Specification.

### 8.13 RESISTANCE TO SOLDERING HEAT

Resistance to Soldering Heat is applicable to Qualification Testing, and to Periodic Testing for renewal of qualification after lapse.

Unless otherwise specified, components shall be subjected to Test Tb of IEC Publication No. 60068-2-20. Unless otherwise specified, the following details shall apply:

- **Stabilisation**  
Prior to the test the components shall be stabilised at  $+22 \pm 3^{\circ}\text{C}$  for a period of 15 minutes minimum.
- **Test Conditions**
  - (a) Test method: 1A ( $+260 \pm 5^{\circ}\text{C}$ )
  - (b) Immersion depth: 2 ( $+0.5 -0$ ) mm from the component body.
  - (c) Immersion time:  $10 \pm 1$  seconds.

No heat sink or thermal screen shall be used during this test.

- **Data Points**  
On completion of testing, the components shall be subjected to standard atmospheric conditions for a recovery period of  $1.5 \pm 0.5$  hours.

After recovery, the components shall be visually examined. There shall be no evidence of damage. Insulation Resistance and Insertion Loss shall be measured as specified in Intermediate and End-Point Electrical Measurements in the Detail Specification.

### 8.14 SHOCK

Components shall be subjected to Test Ea of IEC Publication No. 60068-2-27. The following details shall apply:

- **Test Conditions**
  - (a) Pulse shape: Half-sine.
  - (b) Peak acceleration:  $1000\text{m/s}^2$
  - (c) Pulse duration: 6ms
  - (d) Applied voltage: 100% of rated voltage.
  - (e) Mounting: The components shall be mechanically connected to the shock machine either directly or by means of a fixture. Mounting fixtures shall enable the components to be vibrated in 3 mutually perpendicular axes in turn, which should be so chosen that faults are most likely to be revealed. Components shall be mounted by their normal mounting means and, where applicable, to the torque rating defined in the Detail Specification. Additional restraining straps should be avoided. Unless otherwise specified, components not provided with specific means of mounting shall be clamped on both body and leads (leads shall be clamped at  $6 \pm 1\text{mm}$  from the body). Care should be taken to avoid pinching the leads. If external connections, necessary for measuring and supply purposes, are specified in the Detail Specification, they should add the minimum restraint and mass.

- **Data Points**  
During the test the components shall be monitored for intermittent short-circuits between the terminals and case, or open-circuits between terminals, of duration 0.1ms or longer.

On completion of testing, the components shall be visually examined. There shall be no evidence of damage. Insertion Loss shall be measured as specified in Intermediate and End-Point Electrical Measurements in the Detail Specification.



### 8.15 IMMERSION

Components shall be subjected to Immersion, immediately after Rapid Change of Temperature, as follows:

- Test Conditions
  - (a) Mounting: Components shall be mounted by their normal mounting means and, where applicable, to the torque rating defined in the Detail Specification.
  - (b) Procedure: Components shall undergo 2 cycles of immersion. Each cycle shall consist of immersion in a bath of fresh (tap) water at a temperature of +65 (+5 -0)°C followed by immersion in such water at +25 (+10 -5)°C. The duration of each immersion shall be 15 minutes. Transfer of components from one bath to the other shall be accomplished as rapidly as practicable. After completion of the cycles the components shall be thoroughly and quickly washed and all surfaces wiped or air-blown clean and dry.
- Data Points

On completion of testing, the components shall be visually examined. There shall be no obliteration of marking, and no harmful or extensive corrosion. Plating of metal surfaces shall be at least 90% intact and there shall not be more than 10% corrosion of terminal hardware or mounting surface. After a period of between 4 and 24 hours, Voltage Proof at 90% of rated voltage, Insulation Resistance and Insertion Loss shall be measured as specified in Intermediate and End Point Electrical Measurements in the Detail Specification.

### 8.16 ACCELERATED DAMP HEAT

Accelerated Damp Heat is applicable to Qualification Testing, and to Periodic Testing for renewal of qualification after lapse.

Components shall be subjected, immediately after Rapid Change of Temperature, to Test Db of IEC Publication No. 60068-2-30. Unless otherwise specified, the following details shall apply:

- Mounting

Components shall be mounted by their normal mounting means and, where applicable, to the torque rating defined in the Detail Specification.
- Test Conditions
  - (a) Upper temperature: +65°C
  - (b) Number of cycles: 10 cycles of 24 hours.
  - (c) Applied voltage: 100V or 100% of rated voltage (whichever is less).
- Data Points

After a period of between 4 and 24 hours the components shall be visually examined for evidence of corrosion or obliteration of marking. Voltage Proof at 90% of rated voltage, Insulation Resistance and Insertion Loss shall be measured as specified in Intermediate and End Point Electrical Measurements in the Detail Specification.

### 8.17 OPERATING LIFE

Components shall be subjected to an endurance test in accordance with IEC Publication No. 60384-1 clause 4.23. Unless otherwise specified, the following details shall apply:

- Test Conditions
  - (a) Mounting: Components shall be mounted by their normal mounting means. Screw terminations shall be set, to the torque defined in the Detail Specification, in a clearance hole on a rigid metal plate. Components shall be separated from each other by not less than 25mm and radiation shields may be placed between units, if desired, so that overheating of one unit will not affect a nearby unit.

- (b) Duration:
    - For Qualification Testing, and to Periodic Testing for renewal of qualification after lapse: 2000  $\pm$ 48 hours.
    - For Periodic Testing for extension of qualification: 1000  $\pm$ 24 hours.
  - (c) Temperature: As specified in Operating Life in the Detail Specification.
  - (d) Applied voltage: As specified in Operating Life in the Detail Specification. If AC rated components are tested, the value of the series resistor shall be such that the voltage appearing across the test unit is not less than 95% of the applied voltage. A voltage source shall be used which is capable of supplying at least 1 ampere when a component is short-circuited.
  - (e) Applied current: As specified in Operating Life in the Detail Specification.
  - (f) Charging current: 50pA/pF maximum for  $C \leq 1000\text{pF}$ ; 0.05A maximum for  $C > 1000\text{pF}$
  - (g) Monitoring during Operating Life: A method shall be provided to indicate short-circuits or leakage currents of 1mA or greater.
- Data Points  
Prior to the test, Capacitance shall be measured (initial measurements) as specified in Intermediate and End-Point Electrical Measurements in the Detail Specification.

During testing, a component shall be considered as failed when a temporary or permanent short-circuit or open-circuit occurs in any section of the component, or between any section and the case, or between sections.

For a 1000 hour Operating Life test, testing shall be stopped after 500  $\pm$ 48 hours for intermediate measurements. For a 2000 hour Operating Life test, testing shall be stopped after 500  $\pm$ 48 hours and also 1000  $\pm$ 48 hours for intermediate measurements. The components shall be subjected to standard atmospheric conditions for recovery for 24  $\pm$ 2 hours. Prior to the recovery period, the Insulation Resistance shall be measured at the specified operating life test temperature.

After recovery, Capacitance and Change in Capacitance, Voltage Proof at 90% of rated voltage, Insulation Resistance and Insertion Loss shall be measured as specified in Intermediate and End-Point Electrical Measurements in the Detail Specification. Change in Capacitance shall be related to the initial measurements. On completion of intermediate electrical measurements, components shall be returned to Operating Life testing.

On completion of testing (1000 or 2000 hours), the components shall be subjected to standard atmospheric conditions for recovery for 24  $\pm$ 2 hours. Prior to the recovery period, the Insulation Resistance shall be measured at the specified operating life test temperature.

After recovery, Capacitance, Change in Capacitance, Voltage Proof at 90% of rated voltage, Insulation Resistance and Insertion Loss shall be measured as specified in Intermediate and End-Point Electrical Measurements in the Detail Specification. Change in Capacitance shall be related to the initial measurements.

## 8.18 SOLDERABILITY

Unless otherwise specified, components shall be subjected to Test Ta of IEC Publication No. 60068-2-20. Unless otherwise specified, the following details shall apply:

- Ageing  
Accelerating ageing shall be carried out prior to Solderability in accordance with Ageing 1a (1 hour steam ageing) as specified in Test Ta of IEC Publication No. 60068-2-20.

- Test Conditions  
Test Method 1, 2 or 3 shall be used as appropriate or as specified in the Detail Specification.
  - When using Method 1, the termination shall be immersed up to 2 (+0.5 -0) mm from the point where they emerge from the body. A thermal screen may be employed if defined in the Detail Specification.
  - When using Method 2, a Size 'A' soldering iron shall be used over the area 2 to 5 mm from the component body.
  - When using Method 3, the soldering time shall not exceed 1 second. It shall be followed, after a period of not less than 3 minutes, by the de-wetting test with an immersion 2.5 ±0.5 mm from the component body.
- Data Points  
On completion of the solderability procedure the components shall be visually examined in accordance with the requirements of Para. 4.6.4, 4.7.4 or 4.9.3, as appropriate, of Test Ta of IEC Publication No. 60068-2-20.

8.19 PERMANENCE OF MARKING  
ESCC Basic Specification No. [24800](#).

8.20 ROBUSTNESS OF TERMINATIONS  
Components shall be subjected to Tests Ua<sub>1</sub>, Ub and Uc of IEC Publication No. 60068-2-21, as applicable and as specified in the Detail Specification.

Tests Ub and Uc shall not be applied if the Detail Specification describes the terminations as rigid.

- Mounting  
Components shall be mounted by their normal mounting means and, where applicable, to the torque rating defined in the Detail Specification.
- Procedure
  - Test Ua<sub>1</sub>, Tensile (All types of termination)  
For wire terminations, the loading force shall be as defined in Table 1 of IEC Publication No. 60068-2-21. For terminations other than wire, the load shall be 20N.
  - Test Ub, Bending (Pliable terminations)  
Method 1. Five consecutive bends through an angle of 45° (90° total arc).
  - Test Uc, Torsion (Axial termination wires)  
Method A - Severity 2.

N.B.: When both tests are considered applicable, one half of the test lot shall be subjected to Test Ub and the other half to Test Uc.

- Data Points  
After each of the tests, the components shall be visually examined. There shall be no evidence of damage, but marks on the terminations made by clamping tools are permitted. Voltage Drop shall be measured as specified in Intermediate and End-Point Electrical Measurements in the Detail Specification.

## **9 DATA DOCUMENTATION**

### **9.1 GENERAL**

For the qualification, qualification maintenance and procurement for each lot a data documentation package shall exist in a printed or electronic form.

This package shall be compiled from:

- (a) Cover sheet (or sheets).
- (b) List of equipment (testing and measuring).
- (c) List of test references.
- (d) Special In-Process Controls data (Chart F2).
- (e) Screening Tests data (Chart F3).
- (f) Qualification, Periodic Testing and Lot Validation Testing (when applicable) data (Charts F4A and F4B).
- (g) Failed components list and failure analysis report (when applicable).
- (h) Certificate of Conformity.

Items (a) to (h) inclusive shall be grouped, preferably as subpackages and, for identification purposes, each page shall include the following information:

- ESCC Component Number.
- Manufacturer's name.
- Lot identification.
- Date of establishment of the document.
- Page number.

Whenever possible, documentation should preferably be available in electronic format suitable for reading using a compatible PC. The format supplied shall be legible, durable and indexed. The preferred storage medium is CD-ROM and the preferred file format is PDF.

#### **9.1.1 Qualification and Qualification Maintenance**

In the case of qualification or qualification maintenance, the items listed in Para. 9.1(a) to (h) are required.

#### **9.1.2 Component Procurement and Delivery**

For all deliveries of components procured to this specification, the following documentation shall be supplied:

- (a) Cover sheet (if all of the information is not included on the Certificate of Conformity).
- (b) Certificate of Conformity (including range of delivered serial numbers).

#### **9.1.3 Additional Documentation**

The Manufacturer shall deliver additional documentation containing data and reports to the Orderer, if stipulated in the Purchase Order.

#### **9.1.4 Data Retention/Data Access**

If not delivered, all data shall be retained by the Manufacturer for a minimum of 5 years during which time it shall be available for review, if requested, by the Orderer or the ESCC Executive (for qualified components).

## 9.2 COVER SHEET(S)

The cover sheet(s) of the data documentation package shall include as a minimum:

- (a) Reference to the Detail Specification, including issue and date.
- (b) Reference to the applicable ESCC Generic Specification, including issue and date.
- (c) ESCC Component Number and the Manufacturer's part type number.
- (d) Lot identification.
- (e) Range of delivered serial numbers.
- (f) Number of the Purchase Order.
- (g) Information relative to any additions to this specification and/or the Detail Specification.
- (h) Manufacturer's name and address.
- (i) Location of the manufacturing plant.
- (j) Signature on behalf of Manufacturer.
- (k) Total number of pages of the data package.

## 9.3 LIST OF EQUIPMENT USED

A list of equipment used for tests and measurements shall be prepared. Where applicable, this list shall contain inventory number, Manufacturer's type number, serial number, etc. This list shall indicate for which tests such equipment was used.

## 9.4 LIST OF TEST REFERENCES

This list shall include all Manufacturer's references or codes which are necessary to correlate the test data provided with the applicable tests specified in the tables of the Detail Specification.

## 9.5 SPECIAL IN-PROCESS CONTROLS DATA (CHART F2)

A test result summary shall be compiled showing the total number of components submitted to, and the total number rejected after each of the tests.

## 9.6 SCREENING TESTS DATA (CHART F3)

A test result summary shall be compiled showing the total number of components submitted to, and the total number rejected after each of the tests. For each test requiring electrical measurements the results shall be recorded against component serial number. Component drift calculations shall be recorded for each specified test against component serial number. For Radiographic Inspection, photographic results shall be recorded against component serial number.

## 9.7 QUALIFICATION, PERIODIC TESTING AND LOT VALIDATION TESTING DATA (CHARTS F4A AND F4B)

### 9.7.1 Qualification Testing

A test result summary shall be compiled showing the components submitted to and the number rejected after each test in each subgroup. Component serial numbers for each subgroup shall be identified. For each test requiring electrical measurements the results shall be recorded against component serial number. Where a drift value is specified during a test the drift calculation shall be recorded against component serial number.

**9.7.2** Periodic Testing for Qualification Maintenance

A test result summary shall be compiled showing the components submitted to and the number rejected after each test in each subgroup. Component serial numbers for each subgroup shall be identified. For each test requiring electrical measurements the results shall be recorded against component serial number. Where a drift value is specified during a test the drift calculation shall be recorded against component serial number.

In addition to the full test data a report shall be compiled for each subgroup of Charts F4A and F4B to act as the most recent Periodic Testing summary. These reports shall include a list of all tests performed in each subgroup, the ESCC Component Numbers and quantities of components tested, a statement confirming all the results were satisfactory, the date the tests were performed and a reference to the full test data.

**9.7.3** Lot Validation Testing

A test result summary shall be compiled showing the components submitted to and the number rejected after each test in each subgroup (as applicable). Component serial numbers for each subgroup shall be identified. For each test requiring electrical measurements the results shall be recorded against component serial number. Where a drift value is specified during a test the drift calculation shall be recorded against component serial number.

**9.8** FAILED COMPONENTS LIST AND FAILURE ANALYSIS REPORT

The failed components list and failure analysis report shall provide full details of:

- (a) The reference and description of the test or measurement performed as defined in this specification and/or the Detail Specification during Special In-Process Controls, Screening Tests and Qualification, Periodic Testing and Lot Validation Testing.
- (b) Traceability information including serial number (if applicable) of the failed component.
- (c) The failed parameter and the failure mode of the component.
- (d) Detailed failure analysis (if requested by the ESCC Executive or Orderer).

**9.9** CERTIFICATE OF CONFORMITY

A Certificate of Conformity shall be established in accordance with the requirements of ESCC Basic Specification No. [20100](#) or [25400](#).

**10** DELIVERY

For procurement, for each order, the items forming the delivery are:

- (a) The delivery lot.
- (b) The components used for Lot Validation Testing (as applicable), but not forming part of the delivery lot, if stipulated in the Purchase Order.
- (c) The relevant documentation in accordance with the requirements of Paras. 9.1.2 and 9.1.3.

In the case of a component for which a valid qualification is in force, all data of all components submitted to Lot Validation Testing shall also be copied, when requested, to the ESCC Executive.

For qualification or qualification maintenance, the disposition of the Qualification Test Lot and its related documentation shall be as specified in ESCC Basic Specification No. [20100](#) or [25400](#) and the relevant paragraphs of Section 9 of this specification.

**11**      **PACKAGING AND DESPATCH**

The packaging and despatch of components to this specification shall be in accordance with the requirements of ESCC Basic Specification No. [20600](#).

**12 CHARTS**

**12.1 CHART F1 - GENERAL FLOW FOR PROCUREMENT**

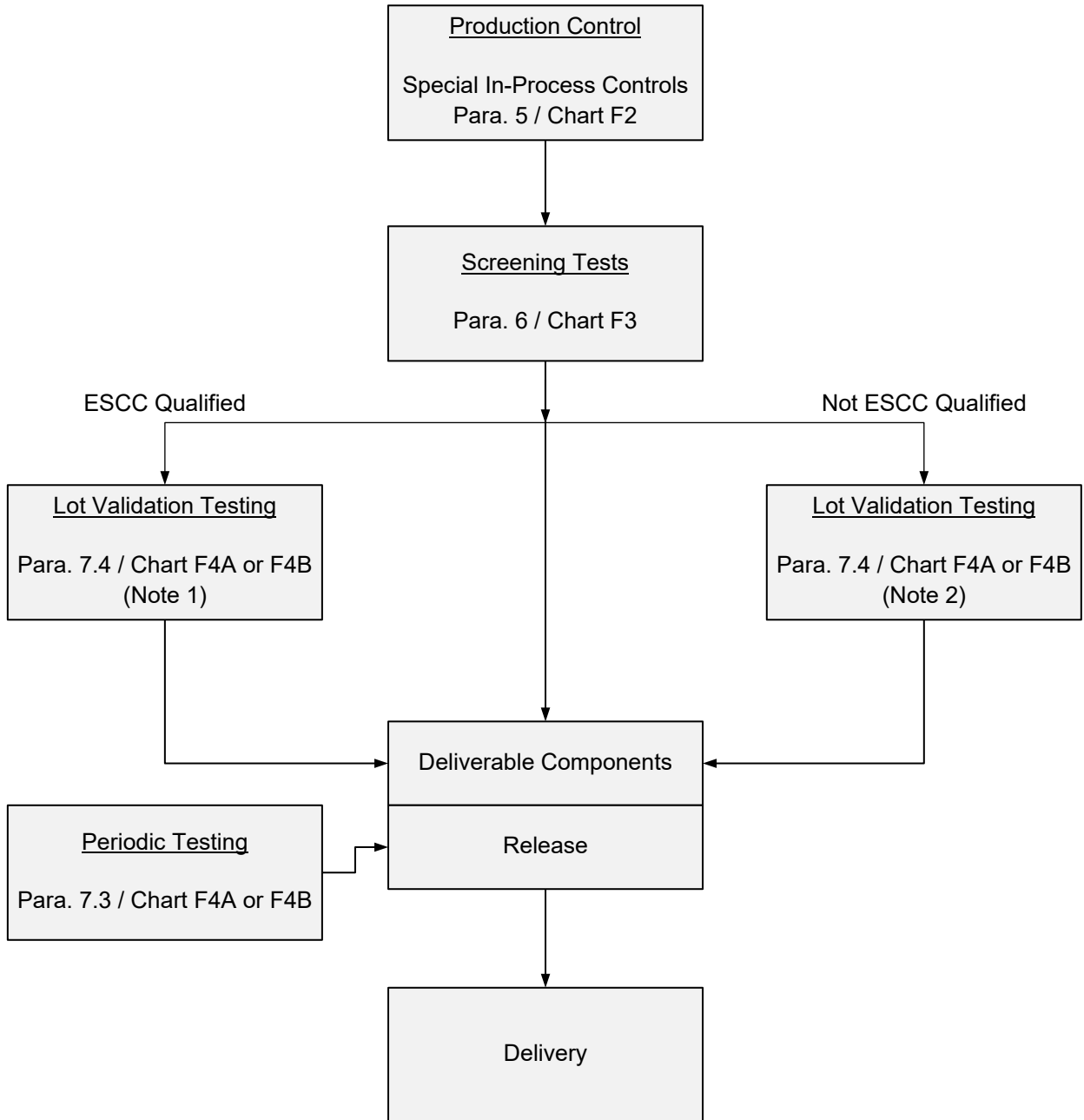

**NOTES:**

1. Lot Validation Testing is not required for qualified components unless specifically stipulated in the Purchase Order.
2. For unqualified components the need for Lot Validation Testing shall be determined by the Orderer and the required testing shall be as stipulated in the Purchase Order (ref. ESCC Basic Specification No. [23100](#)).



12.2 CHART F2 - PRODUCTION CONTROL

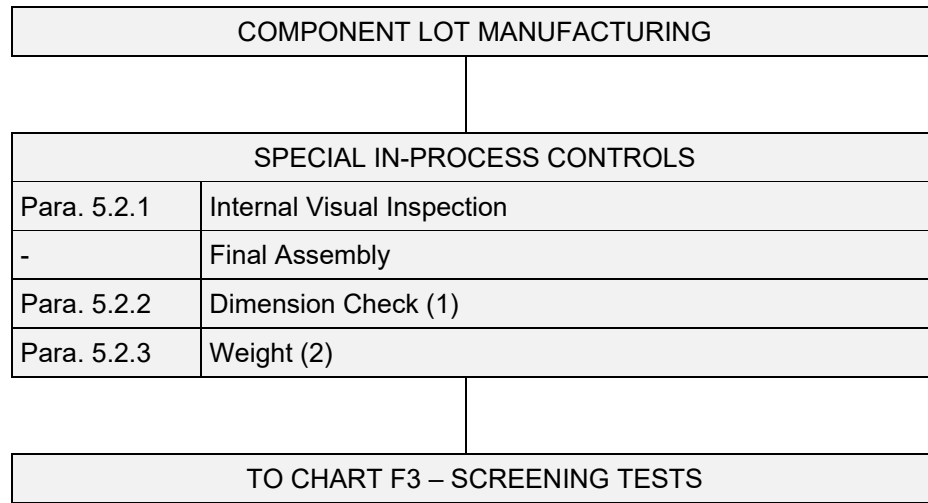

**NOTES:**

1. Performed on a sample basis.
2. Guaranteed but not tested.

12.3 CHART F3 - SCREENING TESTS

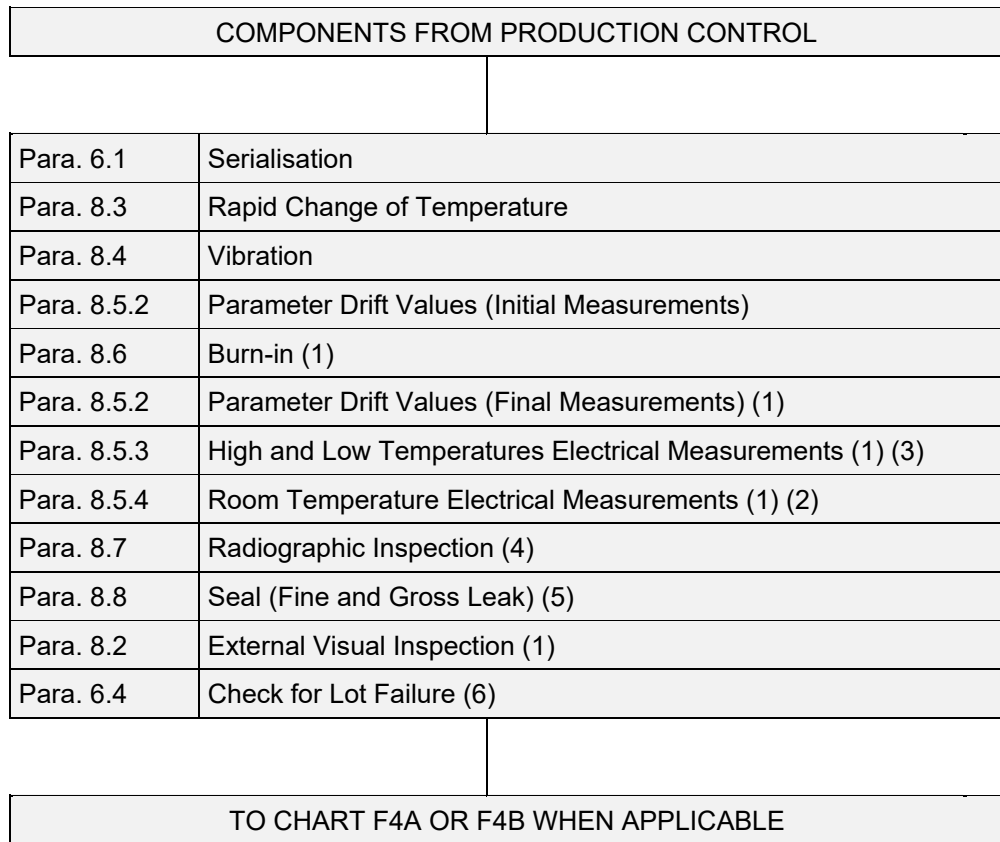

**NOTES:**

1. The lot failure criteria of Para. 6.4 apply to this test.
2. Measurements of Parameter Drift Values need not be repeated in Room Temperature Electrical Measurements.
3. Performed on a sample basis.
4. Radiographic Inspection may be performed at any point during Screening Tests after serialisation.
5. Applicable to hermetically sealed components.
6. Check for Lot Failure shall take into account all failures that may occur during Screening Tests in accordance with Paras. 8.5.2, 8.5.3, 8.5.4 and 8.2 subsequent to Burn-in.

12.4 CHART F4 - QUALIFICATION, PERIODIC TESTING AND LOT VALIDATION TESTING  
 Notes to Charts F4A and F4B are given in Para. 12.4.3.

12.4.1 Chart F4A - Qualification, Periodic Testing and Lot Validation Testing for Hermetically Sealed Components

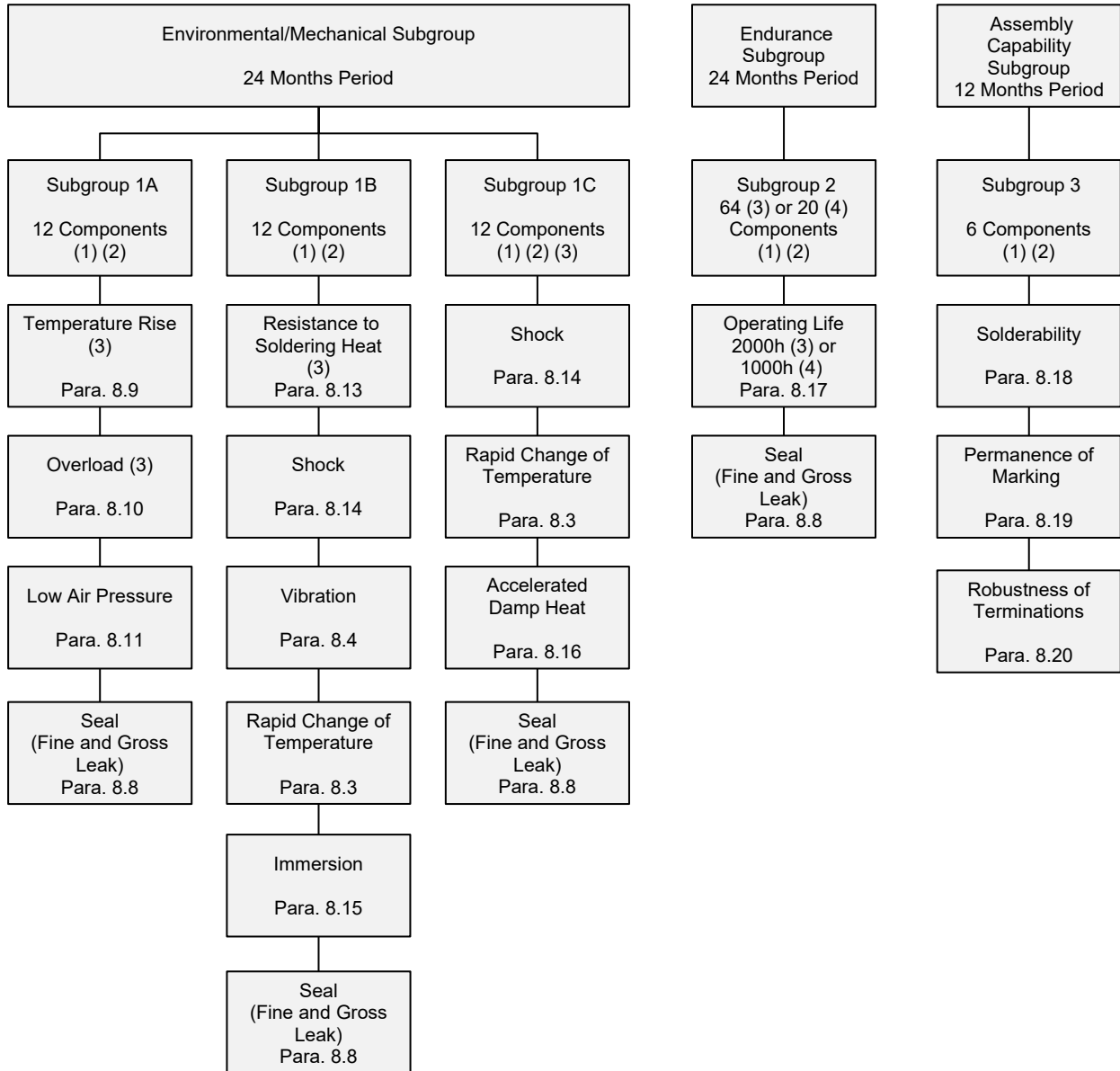

12.4.2 Chart F4B - Qualification, Periodic Testing and Lot Validation Testing for Non-hermetically Sealed Components

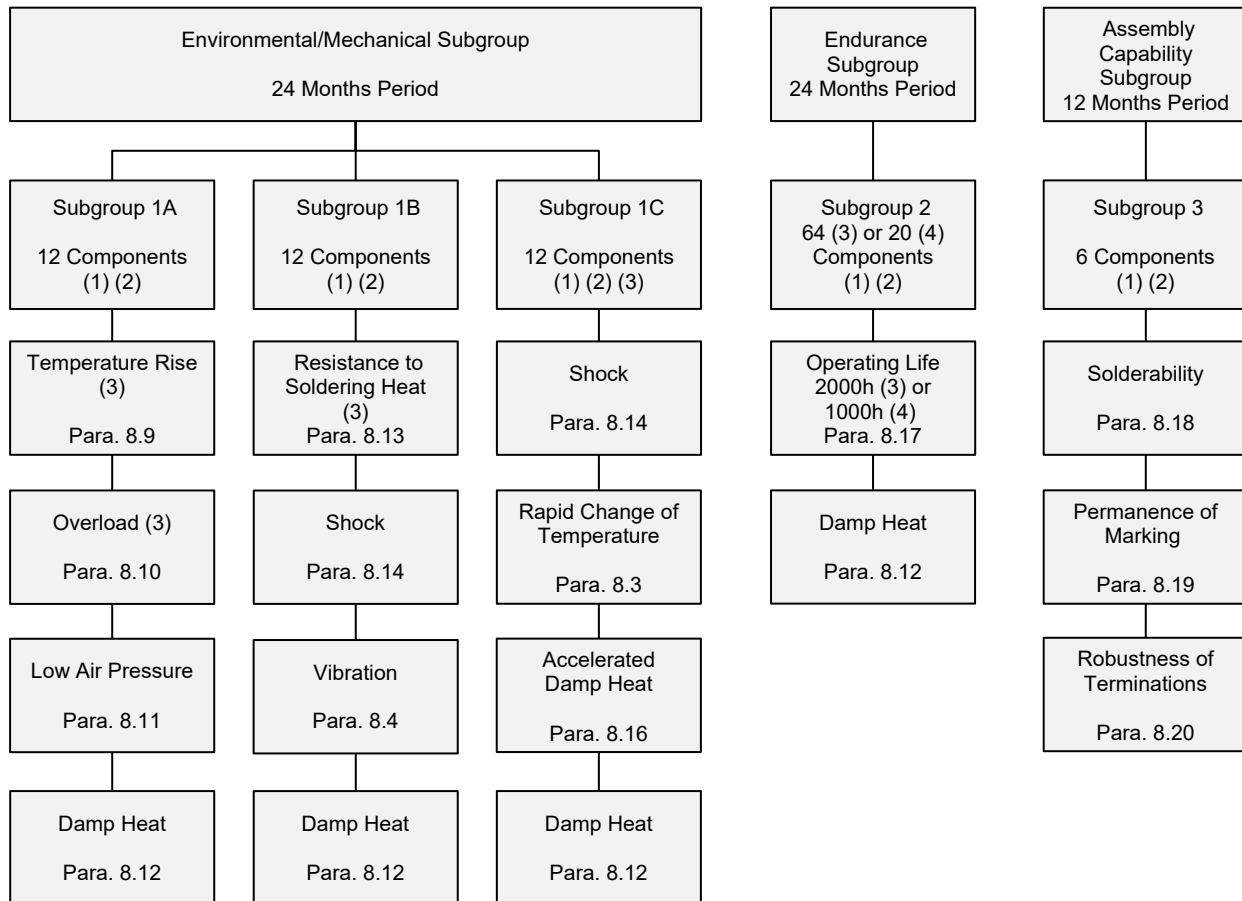

12.4.3 Notes to Charts F4A and F4B

1. For distribution within the subgroups see Para. 7.1.2 for Qualification Testing and Periodic Testing and Para. 7.4 for Lot Validation Testing.  
 For qualification and qualification maintenance, the minimum quantity of components per test vehicle selected for the Qualification Test Lot shall be as follows:
  - Subgroup 1A: 3 components
  - Subgroup 1B: 3 components
  - Subgroup 1C: 3 components
  - Subgroup 2: 16 components
  - Subgroup 3: 4 components
2. No failures are permitted.
3. Only applicable to Qualification Testing, and to Periodic Testing for renewal of qualification after lapse.
4. Only applicable to Periodic Testing for extension of qualification.