



**CONNECTORS, MINIATURE, ELECTRICAL, CIRCULAR,
TRIPLE-START SELF-LOCKING COUPLING, SCOOP-PROOF,
HERMETIC RECEPTACLE AND FEEDTHROUGH,
BASED ON TYPE MIL-DTL-38999 SERIES III**

ESCC Detail Specification No. 3401/057

Issue 6	March 2023
---------	------------



LEGAL DISCLAIMER AND COPYRIGHT

European Space Agency, Copyright © 2023. All rights reserved.

The European Space Agency disclaims any liability or responsibility, to any person or entity, with respect to any loss or damage caused, or alleged to be caused, directly or indirectly by the use and application of this ESCC publication.

This publication, without the prior permission of the European Space Agency and provided that it is not used for a commercial purpose, may be:

- copied in whole, in any medium, without alteration or modification.
- copied in part, in any medium, provided that the ESCC document identification, comprising the ESCC symbol, document number and document issue, is removed.

DOCUMENTATION CHANGE NOTICE

(Refer to <https://escies.org> for ESCC DCR content)

DCR No.	CHANGE DESCRIPTION
1540	Specification upissued to incorporate changes per DCR.

TABLE OF CONTENTS

1	GENERAL	6
1.1	SCOPE	6
1.2	RANGE OF COMPONENTS	6
1.3	MAXIMUM RATINGS	6
1.4	PARAMETER DERATING INFORMATION	6
1.5	PHYSICAL DIMENSIONS	6
2	APPLICABLE DOCUMENTS	6
3	TERMS, DEFINITIONS, ABBREVIATIONS, SYMBOLS AND UNITS	6
4	REQUIREMENTS	18
4.1	GENERAL	18
4.2	DEVIATIONS FROM GENERIC SPECIFICATION	18
4.2.1	Deviations from Special In-Process Controls	18
4.2.2	Deviations from Final Production Tests (Chart II(b))	18
4.2.3	Deviations from Burn-in and Electrical Measurements (Chart III)	18
4.2.4	Deviations from Qualification Tests (Chart IV)	18
4.2.5	Deviations from Lot Acceptance Tests (Chart V)	18
4.3	MECHANICAL REQUIREMENTS	19
4.3.1	Dimension Check	19
4.3.2	Weight	19
4.3.3	Contact Capability	19
4.3.4	Contact Retention (in Insert)	19
4.3.5	Mating and Unmating Forces	19
4.3.6	Insert Retention (in Shell)	19
4.3.7	Jackscrew Retention	19
4.3.8	Contact Insertion and Withdrawal Forces	19
4.3.9	Engagement and Separation Forces	19
4.3.10	Oversize Pin Exclusion	19
4.3.11	Probe Damage	19
4.3.12	Solderability	19
4.4	MATERIALS AND FINISHES	19
4.4.1	Shells and Nuts	19
4.4.2	Insert	20
4.4.3	Contacts	20
4.4.4	Contact Retaining Clip	20
4.4.5	Guiding and Locking Devices	20
4.4.6	Magnetism Level	20
4.5	MARKING	20

4.5.1	General	20
4.5.2	Contact Identification	20
4.5.3	The ESCC Component Number	20
4.5.4	Characteristics	21
4.5.4.1	Shell Type	21
4.5.4.2	Hermetic Version	21
4.5.4.3	Contact Arrangements	21
4.5.4.4	Type of Contact	22
4.5.4.5	Clocking Position	22
4.5.5	Traceability Information	22
4.5.6	Marking of Small Components	22
4.6	ELECTRICAL MEASUREMENTS	22
4.6.1	Electrical Measurements at Room Temperature	22
4.6.2	Electrical Measurements at High and Low Temperatures (Table 3)	22
4.6.3	Circuits for Electrical Measurements (Figure 4)	22
4.7	BURN-IN AND ELECTRICAL MEASUREMENTS (TABLES 4 AND 5)	22
4.8	ENVIRONMENTAL AND ENDURANCE TESTS (CHARTS IV AND V OF ESCC GENERIC SPECIFICATION NO. 3401)	22
4.8.1	Measurements and Inspections on Completion of Environmental Tests	22
4.8.2	Measurements and Inspections at Intermediate Points During Endurance Tests	22
4.8.3	Measurements and Inspections on Completion of Endurance Tests	22
4.8.4	Conditions for Operating Life Test (Part of Endurance Testing) (Table 5)	23
4.8.5	Electrical Circuit for Operating Life Test (Figure 5)	23
4.8.6	Conditions for High Temperature Storage Test (Part of Endurance Testing)	23

1 GENERAL

1.1 SCOPE

This specification details the ratings, physical and electrical characteristics, test and inspection data for Connectors, Miniature, Electrical, Circular, Triple-Start Self-Locking Coupling, Scoop-proof, Hermetic Receptacle and Feedthrough, based on Type MIL-DTL-38999 Series III. It shall be read in conjunction with:

- ESCC Generic Specification No. [3401](#), Connectors, Electrical, Non-Filtered, Circular and Rectangular.
- ESCC Detail Specification No. [3401/056](#), Connectors, Electrical, Circular, Triple-Start Self-Locking Coupling, Scoop-proof, Removable Crimp Contacts, Based on MIL-DTL-38999 Series III.

the requirements of which are supplemented herein.

1.2 RANGE OF COMPONENTS

The different sizes of the connectors and contact types specified herein, which are also covered by this specification, together with their mechanical characteristics, are given in Table 1(a).

1.3 MAXIMUM RATINGS

The maximum ratings, which shall not be exceeded at any time during use or storage, applicable to the connectors specified herein, are scheduled in Table 1(b).

1.4 PARAMETER DERATING INFORMATION

The derating information applicable to the connectors specified herein is shown in Figure 1.

1.5 PHYSICAL DIMENSIONS

The physical dimensions of the connectors specified herein are shown in Figure 2.

2 APPLICABLE DOCUMENTS

The following documents form part of this specification and shall be read in conjunction with it:

- (a) ESCC Generic Specification No. [3401](#), Connectors, Electrical, Non-Filtered, Circular and Rectangular.
- (b) ESCC Detail Specification No. [3401/056](#), Connectors, Electrical, Circular, Triple-Start Self-Locking Coupling, Scoop-proof, Removable Crimp Contacts, Based on MIL-DTL-38999 Series III.
- (c) [MIL-STD-1560](#), Insert Arrangements for MIL-DTL-38999 and MIL-DTL-27599 and MIL-C-29600 Series A Electrical Circular Connectors.
- (d) [MIL-STD-1651](#), Insert Arrangements for MIL-C-5015, MIL-C-22992 and MIL-C-83723 Electrical Connectors.

3 TERMS, DEFINITIONS, ABBREVIATIONS, SYMBOLS AND UNITS

For the purpose of this specification, the terms, definitions, abbreviations, symbols and units specified in ESCC Basic Specification No. [21300](#) shall apply.

TABLE 1(a) – RANGE OF COMPONENTS

Shell Size	Max Weight (g)				Tightening Torque for Mounting Nut Receptacle 07 (Nm) Max	Tightening Torque for Mounting Nut Feedthrough 77 (Nm) Max
	Shell Type					
	00H	01H	07H	77H		
09	25	20	33	90	6.3	11.5
11	35	30	44	115	8.4	15.7
13	42	37	52	140	10.5	16.8
15	48	42	58	160	13.6	17.9
17	57	50	68	200	16.8	20
19	62	55	74	220	18.9	23.1
21	70	63	83	260	21	25.2
23	75	68	85	290	23.1	28.3
25	83	75	92	320	25.2	30.4

Shell Type	Contact Size	Type	Mating End Size	Solder Bucket Size	Accept Wire
Receptacle	22D	Male	22	22	22-24-26
Receptacle	20	Male	20	20	20-22-24
Feedthrough	22D	Male	22 (1)	N/A	None
Feedthrough	20	Male	20 (1)	N/A	None
Feedthrough	16	Male	16 (1)	N/A	None
Feedthrough	12	Male	12 (1)	N/A	None
Feedthrough	8	Male	8 (1)	N/A	None

NOTES:

1. Identical on both sides of feedthrough.

TABLE 1(b) - MAXIMUM RATINGS

No.	Characteristics	Symbol	Maximum Rating	Unit
1	Working Voltage (Sea Level) (1)	U_R		Vrms
	Service rating M		325	
	Service rating I		450	
	Service rating II		575	
2	Rated Current	I_R		A
	Contact Size 22D		3	
	Contact Size 20		5	
	Contact Size 16		10	
	Contact Size 12		17	
	Contact Size 8		33	
3	Operating Temperature Range	T_{op}	-65 to +200	°C
4	Storage Temperature Range	T_{stg}	-65 to +200	°C
5	Tightening Torque for Mounting Nut Shells 07 and 77	T_q	See Table 1(a)	Nm

NOTES:

1. See Para. 4.5.4.3.

FIGURE 1 - PARAMETER DERATING INFORMATION

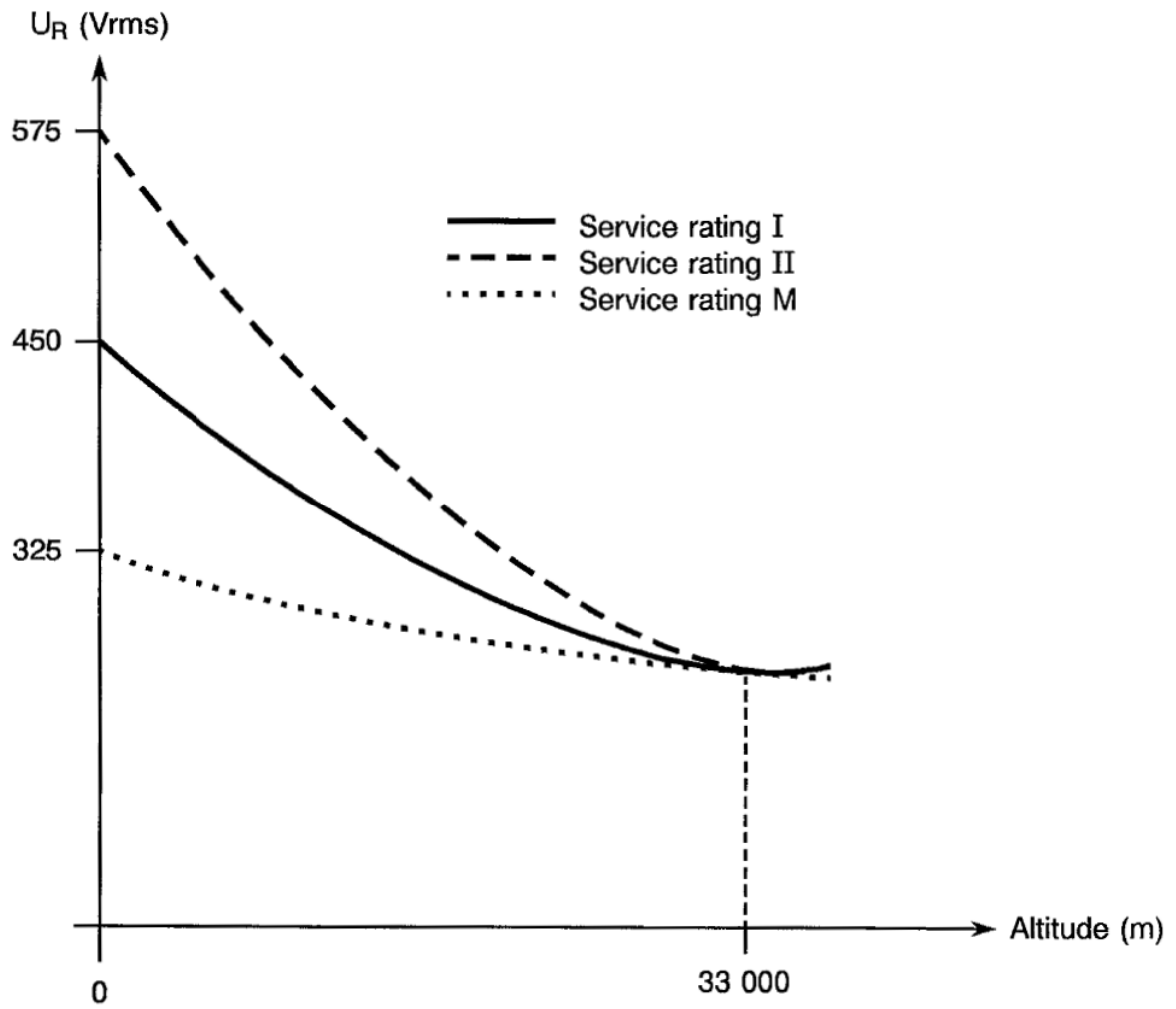
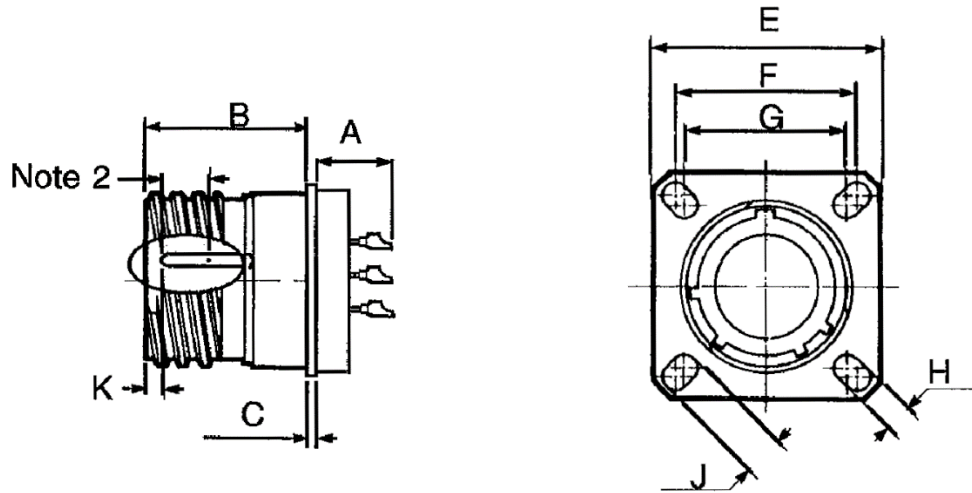

FIGURE 2 - PHYSICAL DIMENSIONS

FIGURE 2(a) - RECEPTACLES

Shell Type 00H: Square flange receptacle



Shell Size	09		11		13		15		17		19		21		23		25	
	Min	Max	Min	Max	Min	Max	Min	Max	Min	Max	Min	Max	Min	Max	Min	Max	Min	Max
A	-	5.7	-	5.7	-	5.7	-	5.7	-	5.7	-	5.7	-	5.7	-	5.7	-	5.7
B	-	21.4	-	21.4	-	21.4	-	21.4	-	21.4	-	21.4	-	21.4	-	21.4	-	21.4
C	1.9	2.6	1.9	2.6	1.9	2.6	1.9	2.6	1.9	2.6	1.9	2.6	1.9	2.6	1.9	2.6	1.9	2.6
E	23.5	24.1	25.9	26.5	28.3	28.9	30.7	31.3	33	33.6	36.2	36.8	39.4	40	42.6	43.2	45.7	46.3
F	18.16	18.36	20.52	20.72	22.91	23.11	24.51	24.71	26.87	27.07	29.26	29.46	31.65	31.85	34.83	35.03	38	38.2
G	14.99	15.19	18.16	18.36	20.52	20.72	22.91	23.11	24.51	24.71	26.87	27.07	29.26	29.46	31.65	31.85	34.83	35.03
H	3.05	3.45	3.05	3.45	3.05	3.45	3.05	3.45	3.05	3.45	3.05	3.45	3.05	3.45	3.71	4.11	3.71	4.11
J	5.29	5.69	4.73	5.13	4.73	5.13	4.73	5.13	4.73	5.13	4.73	5.13	4.73	5.13	5.95	6.35	5.95	6.35
K	9.5	10.54	9.5	10.54	9.5	10.54	9.5	10.54	9.5	10.54	9.5	10.54	9.5	10.54	9.5	10.54	9.5	10.54

NOTES:

1. All dimensions are in millimetres.
2. Measurement point for plating thickness: 4 ± 1 .

FIGURE 2(a) – RECEPTACLES (CONTINUED)

Shell Type 01H: Soldermount receptacle

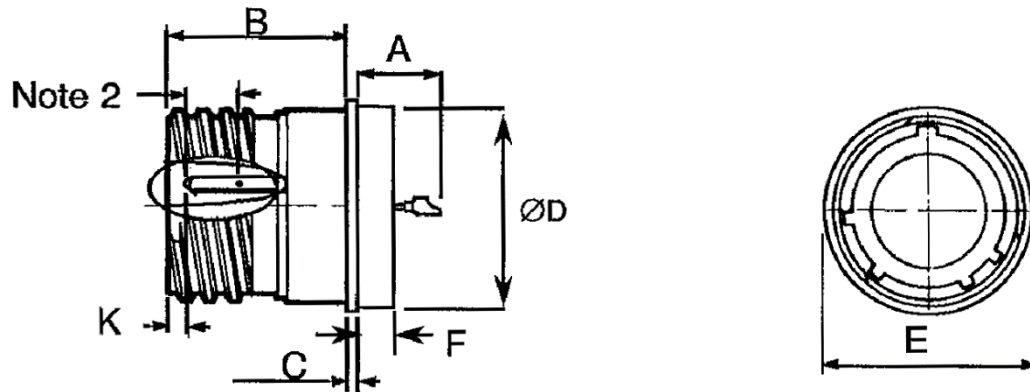

Shell Size	09		11		13		15		17		19		21		23		25	
	Min	Max	Min	Max	Min	Max	Min	Max	Min	Max	Min	Max	Min	Max	Min	Max	Min	Max
A	-	9.7	-	9.7	-	9.7	-	9.7	-	9.7	-	9.7	-	9.7	-	9.7	-	9.7
B	-	17.8	-	17.8	-	17.8	-	17.8	-	17.8	-	17.8	-	17.8	-	17.8	-	17.8
C	0.6	1.2	0.6	1.2	0.6	1.2	0.6	1.2	0.6	1.2	0.6	1.2	0.6	1.2	0.6	1.2	0.6	1.2
ØD	-	17.1	-	19.9	-	23.1	-	26.2	-	29.4	-	31.8	-	35	-	38.2	-	41.3
ØE	-	19.4	-	21.8	-	24.9	-	28.1	-	31.3	-	33.6	-	36.8	-	40	-	43.2
F	-	5.1	-	5.1	-	5.1	-	5.1	-	5.1	-	5.1	-	5.1	-	5.9	-	5.9
K	9.5	10.54	9.5	10.54	9.5	10.54	9.5	10.54	9.5	10.54	9.5	10.54	9.5	10.54	9.5	10.54	9.5	10.54

NOTES:

1. All dimensions are in millimetres.
2. Measurement point for plating thickness: 4 ± 1 .

FIGURE 2(a) – RECEPTACLES (CONTINUED)

Shell Type 07H: Single hole mounting receptacle

L: Max. Panel Thickness

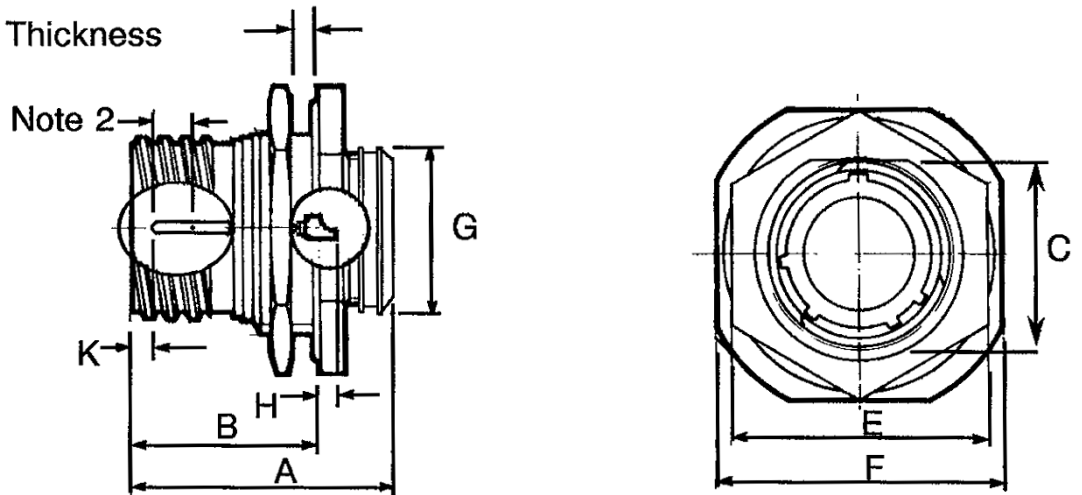

Shell Size	09		11		13		15		17		19		21		23		25	
	Min	Max	Min	Max	Min	Max	Min	Max	Min	Max	Min	Max	Min	Max	Min	Max	Min	Max
A	-	29.2	-	29.2	-	29.3	-	29.3	-	29.3	-	30.1	-	30.1	-	30.1	-	30.1
B	-	22.6	-	22.6	-	22.6	-	22.6	-	22.6	-	22.6	-	22.6	-	22.6	-	22.6
C	16.38	16.63	18.92	19.17	23.67	23.92	26.82	27.07	30	30.25	33.17	33.42	36.35	36.6	39.52	39.77	42.7	42.95
E	-	24	-	27	-	32	-	36	-	37	-	41	-	46	-	50	-	51.23
F	26.6	27.4	31.4	32.2	34.5	35.3	37.7	38.5	40.9	41.7	45.6	46.4	48.8	49.6	52	52.8	55.2	56
G	16.1	16.3	19.1	19.4	22.4	22.7	25.6	25.9	28.7	29	31.9	32.2	35.1	35.4	38.3	38.6	41.4	41.7
H	-	5.3	-	5.3	-	5.1	-	5.1	-	5.1	-	5.1	-	5.1	-	5.9	-	5.9
K	9.5	10.54	9.5	10.54	9.5	10.54	9.5	10.54	9.5	10.54	9.5	10.54	9.5	10.54	9.5	10.54	9.5	10.54
L	1.6	3.2	1.6	3.2	1.6	3.2	1.6	3.2	1.6	3.2	1.6	3.2	1.6	3.2	1.6	3.2	1.6	3.2

NOTES:

1. All dimensions are in millimetres.
2. Measurement point for plating thickness: 4 ± 1 .

FIGURE 2(a) – RECEPTACLES (CONTINUED)

Shell Type 77H: Feedthrough receptacle

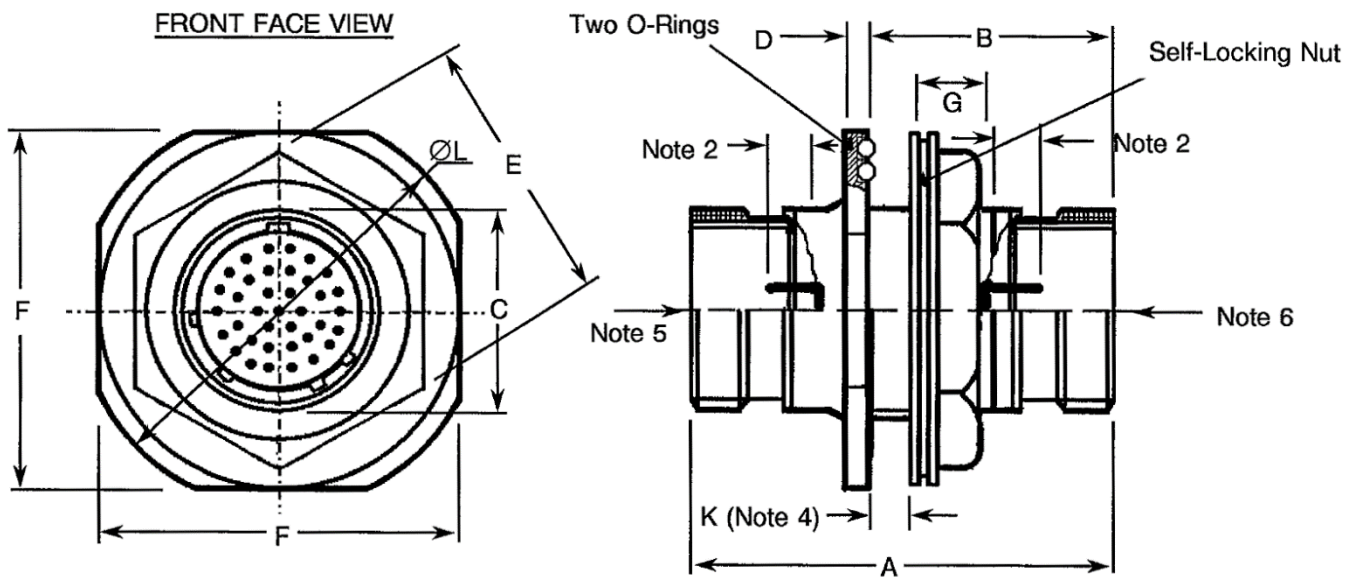

Shell Size	09		11		13		15		17		19		21		23		25	
	Min	Max	Min	Max	Min	Max	Min	Max	Min	Max	Min	Max	Min	Max	Min	Max	Min	Max
A	-	52.8	-	52.8	-	52.8	-	52.8	-	52.8	-	52.8	-	52.8	-	52.8	-	52.8
B	-	31.4	-	31.4	-	32	-	32	-	32	-	32	-	32	-	32	-	32
C	16.38	16.63	18.92	19.17	23.67	23.92	26.82	27.07	30	30.25	33.17	33.42	36.35	36.6	38.52	38.77	42.7	42.95
D	2.5	2.9	2.5	2.9	2.5	2.9	2.5	2.9	2.5	2.9	3.3	3.7	3.3	3.7	3.3	3.7	3.3	3.7
E	22.27	22.5	24.88	25.83	29.77	30.6	32.92	33.76	36.12	37.06	39.27	40.11	42.47	43.31	45.62	46.46	50.56	51.23
F	33	33.59	37.85	38.38	41.02	41.55	44.2	44.79	47.37	47.9	50.55	51.09	53.72	54.25	56.9	57.43	60.07	60.5
G	9.9	10.2	9.9	10.2	9.9	10.2	9.9	10.2	9.9	10.2	9.9	10.2	9.9	10.2	9.9	10.2	9.9	10.2
K	1.57	6.35	1.57	6.35	1.57	6.35	1.57	6.35	1.57	6.35	1.57	6.35	1.57	6.35	1.57	6.35	1.57	6.35
ØL	-	36.88	-	41.58	-	44.75	-	47.93	-	51.1	-	54.28	-	57.48	-	60.63	-	63.8

NOTES:

1. All dimensions are in millimetres.
2. Measurement point for plating thickness: 4 ±1.
3. All other dimensions are in accordance with MIL-DTL-38999 Series III.
4. Panel Thickness.
5. Plug 66 of ESCC No. 3401/056.
6. Plug 06 of ESCC No. 3401/056.

FIGURE 2(b) - HIGH DENSITY CONTACT ARRANGEMENTS - FRONT VIEW MALE INSERT (3)

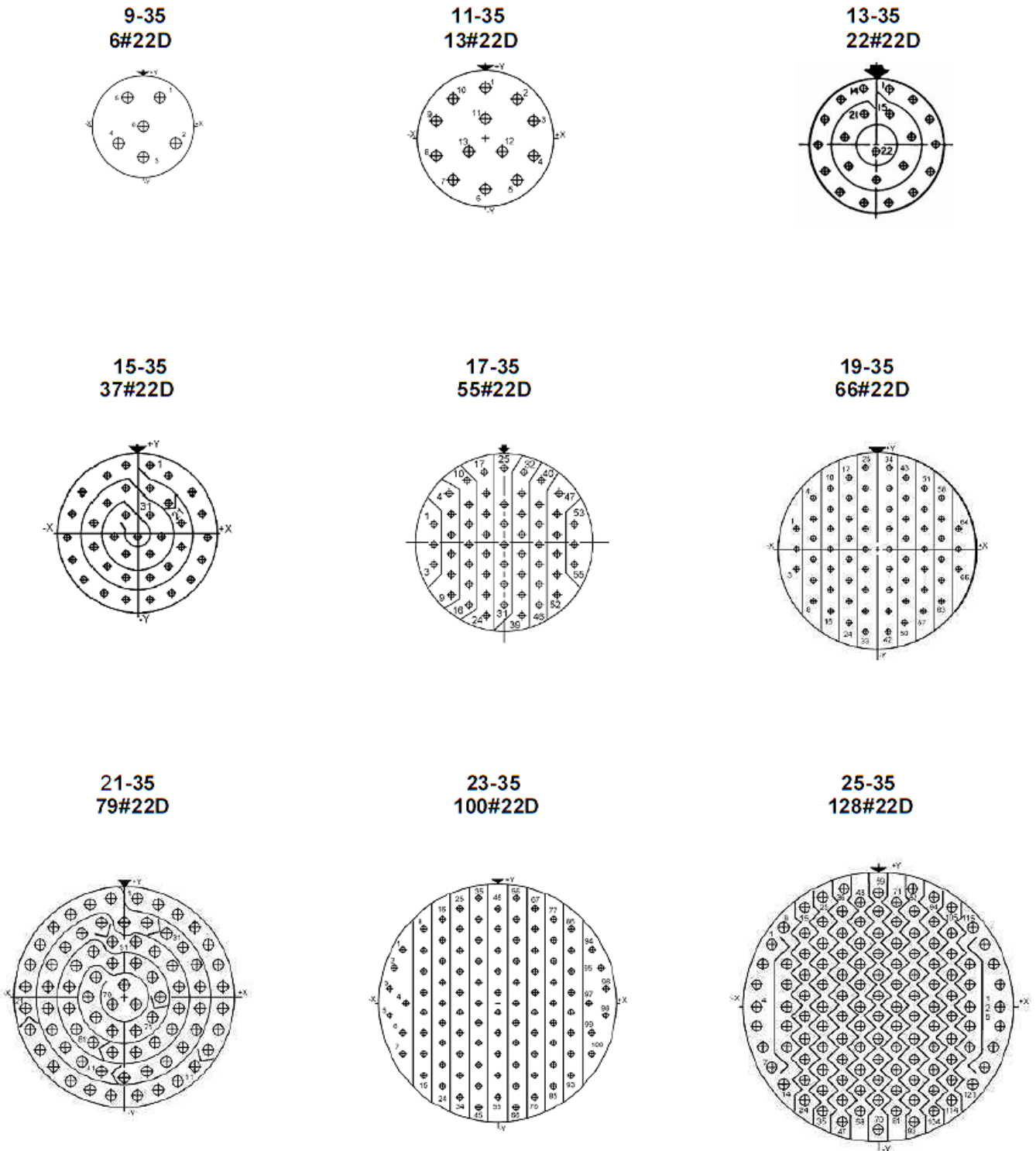

NOTES:

1. Contact locations and identifications in conformity with [MIL-STD-1560](#).
2. Both sides of the inserts shall be marked.
3. For feedthrough receptacles, the view is from the mounting-nut side.

FIGURE 2(b) - STANDARD DENSITY CONTACT ARRANGEMENTS - FRONT VIEW MALE INSERT (3)

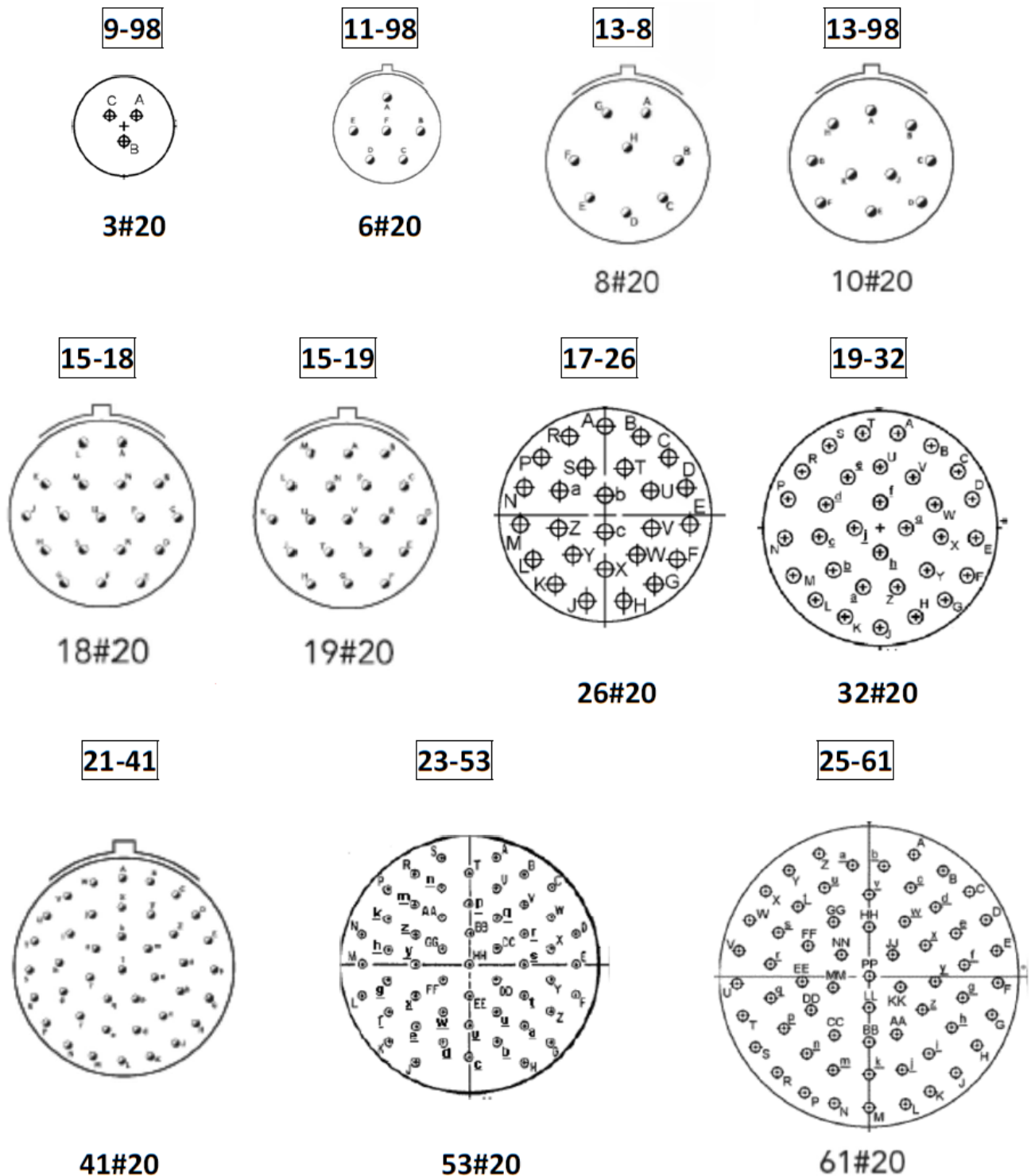

NOTES:

1. Contact locations and identifications in conformity with [MIL-STD-1560](#).
2. Both sides of the inserts shall be marked.
3. For feedthrough receptacles, the view is from the mounting-nut side.

FIGURE 2(b) - SPECIAL CONTACT ARRANGEMENTS - FRONT VIEW MALE INSERT (3)

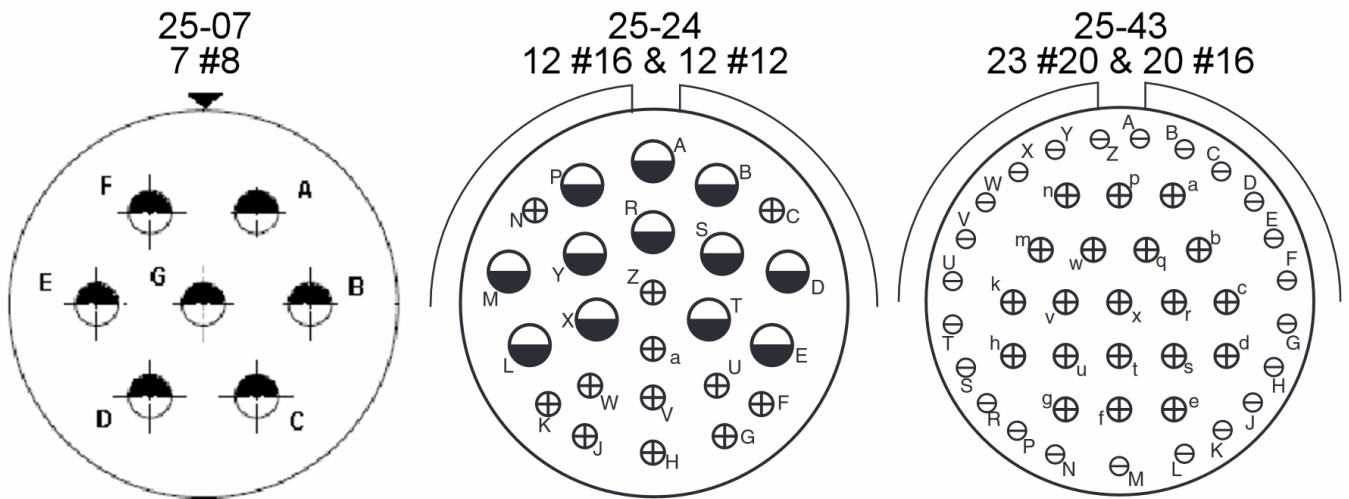
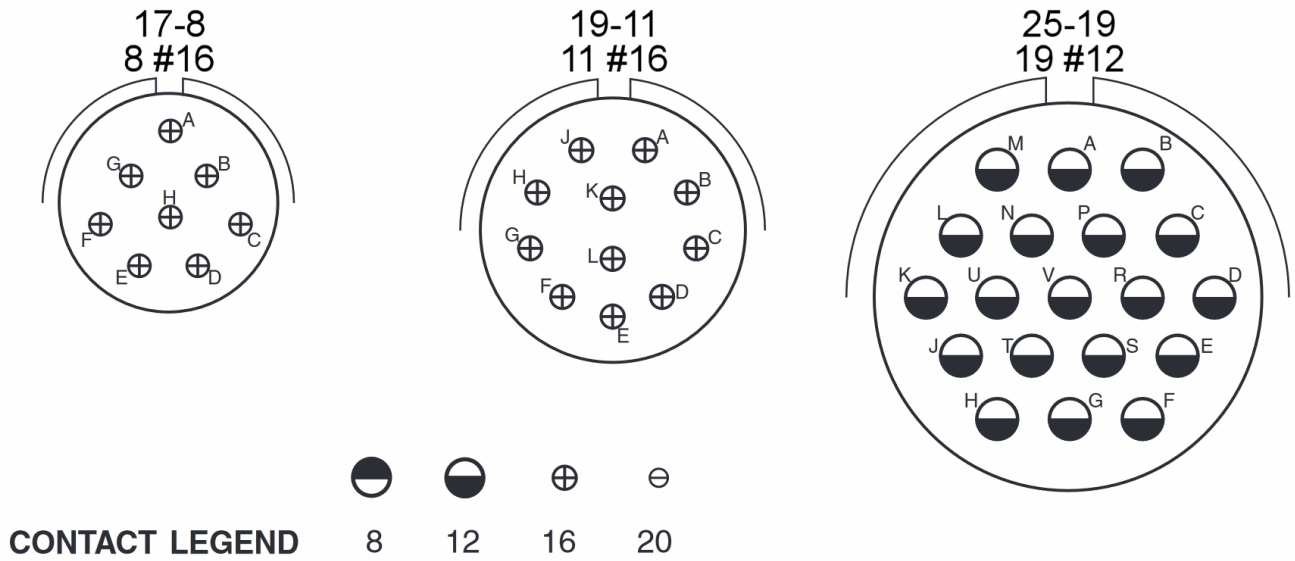

NOTES:

1. Contact locations and identifications in conformity with [MIL-STD-1560](#), except for arrangement 25-07 which is in accordance with [MIL-STD-1651](#).
2. Both sides of the inserts shall be marked.
3. For feedthrough receptacles, the view is from the mounting-nut side.

FIGURE 2(c) - CLOCKING POSITIONS

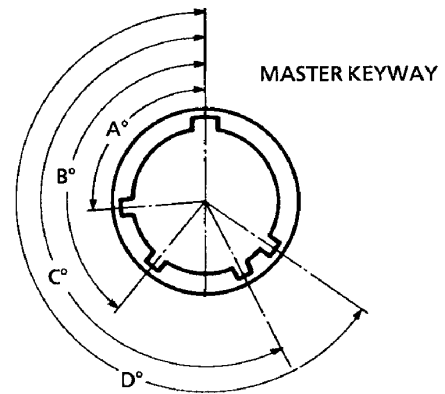

Receptacle front end view

NOTES:

- The clocking position is determined by the different angles of the secondary keyways, the insert being always in the same position with respect to the master keyway position which is fixed.

Shell Size	Angles	Clocking Positions					
		N	A	B	C	D	E
09	A°	105	102	80	35	64	91
	B°	140	132	118	140	155	131
	C°	215	248	230	205	234	197
	D°	265	320	312	275	304	240
11	A°	95	113	90	53	119	51
	B°	141	156	145	156	146	141
	C°	208	182	195	220	176	184
	D°	236	292	252	255	298	242
13	A°	95	113	90	53	119	51
	B°	141	156	145	156	146	141
	C°	208	182	195	220	176	184
	D°	236	292	252	255	298	242
15	A°	95	113	90	53	119	51
	B°	141	156	145	156	146	141
	C°	208	182	195	220	176	184
	D°	236	292	252	255	298	242
17	A°	80	135	49	66	62	79
	B°	142	170	169	140	145	153
	C°	196	200	200	200	180	197
	D°	293	310	244	257	280	272
19	A°	80	135	49	66	62	79
	B°	142	170	169	140	145	153
	C°	196	200	200	200	180	197
	D°	293	310	244	257	280	272
21	A°	80	135	49	66	62	79
	B°	142	170	169	140	145	153
	C°	196	200	200	200	180	197
	D°	293	310	244	257	280	272
23	A°	80	135	49	66	62	79
	B°	142	170	169	140	145	153
	C°	196	200	200	200	180	197
	D°	293	310	244	257	280	272
25	A°	80	135	49	66	62	79
	B°	142	170	169	140	145	153
	C°	196	200	200	200	180	197
	D°	293	310	244	257	280	272

4 REQUIREMENTS

4.1 GENERAL

The complete requirements for procurement of the connectors specified herein are stated in this specification and ESCC Generic Specification No. [3401](#). Deviations from the Generic Specification, applicable to this specification only, are detailed in Para. 4.2.

Deviations from the Generic Specification and this Detail Specification, formally agreed with specific Manufacturers on the basis that the alternative requirements are equivalent to the ESCC requirements and do not affect the components' reliability, are listed in the appendices attached to this specification.

4.2 DEVIATIONS FROM GENERIC SPECIFICATION

4.2.1 Deviations from Special In-Process Controls

For the qualification and LAT1 lots, Para. 5.2.4, Plating Thickness, is not applicable.

4.2.2 Deviations from Final Production Tests (Chart II(b))

- (a) Para. 9.2, Mating Verification: Shall be performed with [3401/056](#) plugs.
- (b) Para. 9.3, Contact Retainer test: Not applicable.
- (c) Para. 9.4, Contact Capability: Not applicable.
- (d) Para. 9.5, Residual Magnetism: Not applicable.

4.2.3 Deviations from Burn-in and Electrical Measurements (Chart III)

Not applicable.

4.2.4 Deviations from Qualification Tests (Chart IV)

- (a) Para. 9.11.2, Sinusoidal Vibration Testing
 - 10 - 55Hz at 8.25mm double amplitude displacement.
 - 56 - 2000Hz at 50g.
 - 1 cycle (10 – 2000 - 10 Hz) per axis at a sweep rate of 1 octave per minute.
- (b) Para. 9.11.2, Random Vibration Testing
 - 20 - 100Hz at +6dB per octave.
 - 100 - 2000Hz, constant at 1g²/Hz.
 - 3 axes.
 - 7 minutes per axis.
- (c) Para. 9.12.1, Shock: 75g, 11 milliseconds, half sine wave.
- (d) Para. 9.15, Joint Strength: Not applicable to feedthrough receptacles Type 77.
- (e) Para. 9.24, Jackscrew Retention: Not applicable.
- (f) Para. 9.27, Maintenance Ageing: Not applicable.
- (g) Para. 9.28, Engagement and Separation Forces: Not applicable.
- (h) Para. 9.29, Oversize Pin Exclusion: Not applicable.
- (i) Para. 9.30, Probe Damage: Not applicable.

4.2.5 Deviations from Lot Acceptance Tests (Chart V)

- (a) Para. 9.28, Engagement and Separation Forces: Not applicable.
- (b) Para. 9.29, Oversize Pin Exclusion: Not applicable.
- (c) Para. 9.30, Probe Damage: Not applicable.

4.3 MECHANICAL REQUIREMENTS

4.3.1 Dimension Check

The dimensions of the connectors specified herein shall be verified in accordance with requirements set out in Para. 9.6 of ESCC Generic Specification No. [3401](#) and shall conform to those shown in Figure 2 of this specification.

4.3.2 Weight

The maximum weight of the connectors specified herein shall be as specified in Table 1(a).

4.3.3 Contact Capability

Not applicable.

4.3.4 Contact Retention (in Insert)

The minimum contact retention force shall be 44 Newtons for size 22D contacts, 67 Newtons for size 20 contacts and 100 Newtons for size 16, 12 and 8 contacts.

4.3.5 Mating and Unmating Forces

The forces applied for the mating and unmating of the connectors (axial and torque) shall conform to the values specified in Table 1(a) of ESCC Detail Specification No. [3401/056](#).

4.3.6 Insert Retention (in Shell)

Connector inserts shall withstand a pressure of 70N/cm² without being dislodged from the shell.

4.3.7 Jackscrew Retention

Not applicable.

4.3.8 Contact Insertion and Withdrawal Forces

Not applicable.

4.3.9 Engagement and Separation Forces

Not applicable.

4.3.10 Oversize Pin Exclusion

Not applicable.

4.3.11 Probe Damage

Not applicable.

4.3.12 Solderability

Size A soldering iron shall be used. Not applicable to feedthrough receptacle Type 77.

4.4 MATERIALS AND FINISHES

The materials and finishes shall be as specified herein. Where a definite material is not specified, a material which will enable the connectors specified herein to meet the performance requirements of this specification shall be used. Acceptance or approval of any constituent material does not guarantee acceptance of the finished product.

4.4.1 Shells and Nuts

Shells and mounting nut shall be made of dull, low reflective, passivated stainless steel.

4.4.2 Insert

The insert shall be made of sintered glass. The interface inserts shall be made of silicone rubber.

4.4.3 Contacts

The contacts shall be made of nickel-iron with nickel underplate and gold finish (minimum thickness: 1.27µm).

4.4.4 Contact Retaining Clip

Not applicable.

4.4.5 Guiding and Locking Devices

Not applicable.

4.4.6 Magnetism Level

Not applicable.

4.5 MARKING**4.5.1** General

The marking of all components delivered to this specification shall be in accordance with the requirements of ESCC Basic Specification No. 21700 and the following paragraphs. Each component shall be marked in respect of:

- (a) Contact Identification.
- (b) The ESCC Component Number.
- (c) Characteristics.
- (d) Traceability Information.

4.5.2 Contact Identification

Contact identification shall be marked in accordance with Figure 2(b).

4.5.3 The ESCC Component Number

The ESCC Component Number shall be constituted and marked as follows:

Example: 340105701B

- Detail Specification Reference: 3401057
- Type Variant (Note 1): 01
- Testing Level: B

NOTES:

1. Marking of the Type Variant Number is mandatory. No further reference to type variant is made in this specification.

4.5.4 Characteristics

The characteristics to be marked in the following order of precedence are:

- (a) Shell Type.
- (b) Hermetic Version.
- (c) Contact Arrangement.
- (d) Type of Contact.
- (e) Clocking position.

The information shall be constituted and marked as follows:

Example: 00H19-32PN

- Shell Type: 00
- Hermetic Version: H
- Contact Arrangement: 19-32
- Type of Contact: P
- Clocking Position: N

4.5.4.1 *Shell Type*

The shell type shall be indicated by the numbers specified hereafter:

Code Number	Shell Type
00	Square flange receptacle
01	Solder mount receptacle
07	Single hole mounting receptacle
77	Feedthrough receptacle

4.5.4.2 *Hermetic Version*

The hermetic version shall be indicated by the letter "H".

4.5.4.3 *Contact Arrangements*

The number of contacts shall be as shown in Figure 2(b) and contact arrangements shall be indicated by the codes specified hereafter:

Code	Service Rating	Code	Service Rating
9-35	M	19-11	II
9-98	I	19-35	M
11-35	M	19-32	I
11-98	I	21-35	M
13-8	I	21-41	I
13-35	M	23-35	M
13-98	I	23-53	I
15-18	I	25-07	I
15-35	M	25-19	I
15-19	I	25-24	II
17-8	II	25-35	M
17-35	M	25-43	I
17-26	I	25-61	I

4.5.4.4 *Type of Contact*

The contact type shall be indicated by the following code letter:

Code Letter	Contact Type
P	Male

4.5.4.5 *Clocking Position*

Clocking positions are as shown in Figure 2(c) and shall be designated by the following code letters: A, B, C, D and E. Code letter N indicates the standard clocking position. For feedthrough receptacle Type 77, the clocking position shall be identical on both sides.

4.5.5 Traceability Information

Traceability information shall be marked in accordance with the requirements of ESCC Basic Specification No. [21700](#).

4.5.6 Marking of Small Components

Where it is considered that a component is too small to accommodate the marking as specified above, as much as space permits shall be marked. The order of precedence shall be as specified in Para. 4.5.1. The marking information in full shall accompany each component in its primary package.

4.6 ELECTRICAL MEASUREMENTS

4.6.1 Electrical Measurements at Room Temperature

The parameters to be measured in respect of electrical characteristics are scheduled in Table 2. Unless otherwise specified these measurements shall be performed at $T_{amb} = +22 \pm 3^{\circ}\text{C}$.

4.6.2 Electrical Measurements at High and Low Temperatures (Table 3)

Not applicable.

4.6.3 Circuits for Electrical Measurements (Figure 4)

Not applicable.

4.7 BURN-IN AND ELECTRICAL MEASUREMENTS (TABLES 4 AND 5)

Not applicable.

4.8 ENVIRONMENTAL AND ENDURANCE TESTS (CHARTS IV AND V OF ESCC GENERIC SPECIFICATION No. [3401](#))

4.8.1 Measurements and Inspections on Completion of Environmental Tests

The parameters to be measured and inspections to be performed on completion of environmental testing shall be those specified in Table 6. Unless otherwise specified, the measurements shall be performed at $T_{amb} = +22 \pm 3^{\circ}\text{C}$.

4.8.2 Measurements and Inspections at Intermediate Points During Endurance Tests

Not applicable.

4.8.3 Measurements and Inspections on Completion of Endurance Tests

The parameters to be measured and inspections to be performed on completion of endurance testing shall be those specified in Table 6. Unless otherwise specified, the measurements shall be performed at $T_{amb} = +22 \pm 3^{\circ}\text{C}$.

4.8.4 Conditions for Operating Life Test (Part of Endurance Testing) (Table 5)
Not applicable.

4.8.5 Electrical Circuit for Operating Life Test (Figure 5)
Not applicable.

4.8.6 Conditions for High Temperature Storage Test (Part of Endurance Testing)
The requirements for the high temperature storage test are specified in Section 9 of ESCC Generic Specification No. 3401. The conditions for high temperature storage testing shall be the maximum storage temperature specified in Table 1(b) of this specification.

TABLE 2 - ELECTRICAL MEASUREMENTS AT ROOM TEMPERATURE

No.	Characteristics	Symbol	Spec. and/or Test Method	Test Condition	Limits		Unit
					Min.	Max.	
1	Insulation Resistance	R _i	ESCC No. 3401 Para. 9.1.1.1	Para. 9.1.1.1	5000	-	MΩ
2	Voltage Proof Leakage Current	I _L	ESCC No. 3401 Para. 9.1.1.2	Service Rating II : 2300 Vrms Service Rating I : 1800 Vrms Service Rating M : 1300 Vrms	-	2	mA
3	Mated Shell Conductivity (Voltage Drop) (Note 1)	V _d	ESCC No. 3401 Para. 9.1.1.4	Para. 9.1.1.4	Not applicable		mV
4	Contact Resistance (Low Level Current)	R _{cl}	ESCC No. 3401 Para. 9.1.1.3	Para. 9.1.1.3 Size 22D Size 20 Size 16 Size 12 Size 8	-	Note 2 50 25 12 6 2.5	mΩ
5	Contact Resistance (Rated Current)	R _{cr}	ESCC No. 3401 Para. 9.1.1.3	Para. 9.1.1.3 Size 22D Size 20 Size 16 Size 12 Size 8	-	Note 2 60 30 15 8 3	mΩ

NOTES:

1. Applicable to mated connectors with grounding option.
2. With 1 plug on each side of the feedthrough, double the maximum limit.

TABLES 3, 4 AND 5

Not applicable.

TABLE 6 – MEASUREMENTS AND INSPECTIONS ON COMPLETION OF ENVIRONMENTAL AND ENDURANCE TESTS

No.	ESCC Generic Spec. No. 3401		Measurements and Inspections		Symbol	Limits		Unit
	Environmental and Endurance Tests (Note 1)	Test Method and Conditions	Identification	Conditions		Min.	Max.	
01	Wiring	Para. 9.10 & Table 1(a) of this spec.	Low Level Contact Resistance	Table 2, Item 1	R _{Cl}	Table 2, Item 1		
02	Vibration	Para. 9.11 & Para. 4.2.4 of this spec.	Initial Measurements Coupling Screw(s) Unlocking Torque Final Measurements Full Engagement Coupling Screw(s) Unlocking Torque Drift Visual Examination	-	-	Not applicable		
					Δ	Not applicable		%
					-	-	-	
03	Shock or Bump	Para. 9.12 & Para. 4.2.4 of this spec.	Full Engagement Visual Examination	-	-	-	-	
04	Climatic Sequence	Para. 9.13	Dry Heat Insulation Resistance Low Air Pressure Voltage Proof Leakage Current Damp Heat Insulation Resistance External Visual Inspection Insulation Resistance Voltage Proof Leakage Current	Table 2 Item 1 250 Vrms Immediately after test Table 2 Item 1 After 1-24 hrs Recovery ESCC 3401 Para. 9.7 Table 2 Item 1 Table 2 Item 2	R _i I _L R _i - R _i I _L	1000 - Table 2 Item 2 100 - ESCC 3401 Para. 9.7 Table 2 Item 1 Table 2 Item 2	MΩ MΩ MΩ	
05	Seal Test	Para. 9.9	ESCC 3401 Para. 9.9	-	-	ESCC 3401 Para. 9.9		
06	Plating Thickness	Para. 9.14	Thickness	-	-	Para. 4.4.3 of this spec.		
07	Joint Strength	Para. 9.15	ESCC 3401 Para. 9.15	-	-	ESCC 3401 Para. 9.15		
08	Rapid Change of Temperature	Para. 9.16	Visual Examination Insulation Resistance Voltage Proof Leakage Current	- Table 2 Item 1 Table 2 Item 2	- R _i I _L	- - Table 2 Item 1 Table 2 Item 2		
09	Contact Retention (In Insert)	Para. 9.17 & Para. 4.3.4 of spec.	Contact Retention	-	-	Para. 4.3.4		

No.	ESCC Generic Spec. No. 3401		Measurements and Inspections		Symbol	Limits		Unit
	Environmental and Endurance Tests (Note 1)	Test Method and Conditions	Identification	Conditions		Min.	Max.	
10	Endurance	Para. 9.18	Initial Measurements Mating/Unmating Forces Low Level Contact Resistance Mated Shell Conductivity Final Measurements Visual Examination Mating/Unmating Forces Low Level Contact Resistance Drift Mated Shell Conductivity Insulation Resistance Voltage Proof Leakage Current	- Table 2 Item 4 Table 2 Item 3 - - - Table 2 Item 3 Table 2 Item 1 Table 2 Item 2	F R_{cl} V_d - F ΔR_{cl} V_d R_i I_L	Para. 4.3.5 of this spec. Record Values Not applicable - - Para. 4.3.5 of this spec. - 3 Not applicable Table 2 Item 1 Table 2 Item 2	mΩ	
11	Permanence of Marking	Para. 9.19	As applicable	-	-	-	-	
12	Mating/Unmating Forces	Para. 9.20	Force	-	F	Para. 4.3.5 of this spec.		
13	High Temperature Storage	Para. 9.21	Initial Measurements Low Level Contact Resistance Mated Shell Conductivity Final Measurements Visual Examination Mating/Unmating Forces Low Level Contact Resistance Drift Rated Current Contact Resistance Mated Shell Conductivity Insulation Resistance Voltage Proof Leakage Current Contact Retention (In Insert)	Table 2 Item 4 Table 2 Item 3 - - Table 2 Item 4 Table 2 Item 5 Table 2 Item 3 Table 2 Item 1 Table 2 Item 2 Para. 4.3.4 of this spec.	R_{cl} V_d - F ΔR_{cl} R_{cr} V_d R_i I_L -	Record Values Not applicable - - Para. 4.3.5 of this spec. - 3 Table 2 Item 5 Not applicable Table 2 Item 1 Table 2 Item 2 Para. 4.3.4	mΩ	
14	Corrosion	Para. 9.22	Visual Examination	-	-	-	-	
15	Insert Retention (In Shell)	Para. 9.23 & Para. 4.3.6 of this spec.	Visual Examination	-	-	Para. 4.3.6		
16	Jackscrew Retention	Para. 9.24 & Para. 4.3.7 of this spec.	Force	-	-	Not applicable		

No.	ESCC Generic Spec. No. 3401		Measurements and Inspections		Symbol	Limits		Unit
	Environmental and Endurance Tests (Note 1)	Test Method and Conditions	Identification	Conditions		Min.	Max.	
17	High Temperature Measurements	Para. 9.25	Insulation Resistance	Table 2 Item 1	R _i	500	-	MΩ
18	Overload Test	Para. 9.26	Internal Temperature	-	T	-	+100	°C
			Rated Current Contact Resistance	Table 2 Item 5	R _{cr}	Table 2 Item 5		
			Mated Shell Conductivity	Table 2 Item 3	V _d	Not applicable		
			Insulation Resistance	Table 2 Item 1	R _i	Table 2 Item 1		
			Voltage Proof Leakage Current	Table 2 Item 2	I _L	Table 2 Item 2		
19	Maintenance Aging	Para. 9.27	Visual Examination	-	-	-	-	
			Contact Retention	Para. 4.3.4 of this spec.		Not applicable		
			Contact Insertion & Withdrawal Forces	Para. 4.3.8 of this spec.		Not applicable		
20	Engage/Separation Forces	Para. 9.28 & Para. 4.3.9 of this spec.	Force	-	-	Not applicable		
21	Oversize Pin Exclusion	Para. 9.29 & Para. 4.3.10 of this spec.	-	-	-	Not applicable		
22	Probe Damage	Para. 9.30 & Para. 4.3.11 of this spec.	Contact Separation Force	Para. 4.3.9 of this spec.	F	Not applicable		
23	Solderability	Para. 9.31 & Para. 4.3.12 of this spec.	-	-	-	ESCC 3401 Para. 9.31		

NOTES:

1. The tests in this Table refer to either Chart IV or V and shall be used as applicable.