



**CONNECTORS, ELECTRICAL, RECTANGULAR,
NON-REMOVABLE PRESS-FIT SIGNAL
CONTACTS AND REMOVABLE PRESS-FIT POWER
CONTACTS**

BASED ON TYPES SDD, SND, SCBM

ESCC Detail Specification No. 3401/098

Issue 2	April 2023
---------	------------



LEGAL DISCLAIMER AND COPYRIGHT

European Space Agency, Copyright © 2023. All rights reserved.

The European Space Agency disclaims any liability or responsibility, to any person or entity, with respect to any loss or damage caused, or alleged to be caused, directly or indirectly by the use and application of this ESCC publication.

This publication, without the prior permission of the European Space Agency and provided that it is not used for a commercial purpose, may be:

- copied in whole, in any medium, without alteration or modification.
- copied in part, in any medium, provided that the ESCC document identification, comprising the ESCC symbol, document number and document issue, is removed.

DOCUMENTATION CHANGE NOTICE

(Refer to <https://escies.org> for ESCC DCR content)

DCR No.	CHANGE DESCRIPTION
1543, 1544	Specification updated to incorporate changes per DCR.

TABLE OF CONTENTS

1	GENERAL	6
1.1	SCOPE	6
1.2	RANGE OF COMPONENTS AND COMPONENT TYPE VARIANTS	6
1.3	MAXIMUM RATINGS	6
1.4	PARAMETER DERATING INFORMATION	6
1.5	PHYSICAL DIMENSIONS	6
2	APPLICABLE DOCUMENTS	6
3	TERMS, DEFINITIONS, ABBREVIATIONS, SYMBOLS AND UNITS	7
4	REQUIREMENTS	21
4.1	GENERAL	21
4.2	DEVIATIONS FROM GENERIC SPECIFICATION	21
4.2.1	Deviations from Special In-Process Controls	21
4.2.2	Deviations from Final Production Tests (Chart II)	21
4.2.3	Deviations from Burn-in and Electrical Measurements (Chart III)	21
4.2.4	Deviations from Qualification Tests (Chart IV)	21
4.2.5	Deviations from Lot Acceptance Tests (Chart V)	23
4.3	MECHANICAL REQUIREMENTS	24
4.3.1	Dimension Check	24
4.3.2	Weight	24
4.3.3	Contact Capability	24
4.3.4	Contact Retention (in insert)	24
4.3.5	Mating and Unmating Forces	24
4.3.6	Insert Retention (in Shell)	24
4.3.7	Contact Insertion and Withdrawal Forces	24
4.3.8	Engagement and Separation Forces	25
4.3.9	Oversize Pin Exclusion	25
4.3.10	Probe Damage	25
4.3.11	Press-fit Insertion Force	25
4.4	MATERIALS AND FINISHES	26
4.4.1	Shells	26
4.4.2	Inserts, Additional Spacing Insert	26
4.4.3	Contacts	26
4.4.4	Contact Retaining Clip	26
4.4.5	Guiding and Locking Devices	26
4.4.6	Magnetism Level	26
4.5	MARKING	26
4.5.1	General	26



4.5.2	The ESCC Component Number	27
4.5.2.1	Characteristics Codes	27
4.5.3	Traceability Information	28
4.6	ELECTRICAL MEASUREMENTS	28
4.6.1	Electrical Measurements at Room Temperature	28
4.7	ENVIRONMENTAL AND ENDURANCE TESTS (CHARTS IV AND V OF ESCC GENERIC SPECIFICATION NO. 3401)	29
4.7.1	Measurements and Inspections on Completion of Environmental Tests	29
4.7.2	Measurements and Inspections on Completion of Endurance Tests	29
4.7.3	Conditions for High Temperature Storage Test (Part of Endurance Testing)	29

1 GENERAL

1.1 SCOPE

This specification details the ratings, physical and electrical characteristics, test and inspection data for Connectors, Electrical, Rectangular, Non-removable Press-fit Contacts, Standard (Gauge 20), High Density (Gauge 22) and Removable Press-fit Contacts, Power (Gauge 8), based on types SDD, SND, SCBM.

It shall be read in conjunction with:

- ESCC Generic Specification No. [3401](#), Connectors, Electrical, Non-Filtered, Circular and Rectangular.
- ESCC Detail Specification No. [3401/022](#), Accessories for Rectangular Connectors [3401/001](#), [3401/002](#), [3401/098](#) and Connector Savers [3401/020](#), [3401/080](#).
- ESCC Detail Specification No. [3401/099](#), Contacts, Power, Press-fit Type for [3401/098](#) Connectors.

the requirements of which are supplemented herein.

1.2 RANGE OF COMPONENTS AND COMPONENT TYPE VARIANTS

The different sizes of the connectors and contact types specified herein, which are also covered by this specification, together with their mechanical characteristics, are given in Table 1(a).

1.3 MAXIMUM RATINGS

The maximum ratings, which shall not be exceeded at any time during use or storage, applicable to the connectors specified herein, are given in Table 1(b).

1.4 PARAMETER DERATING INFORMATION

The applicable derating information for the connectors specified herein is shown in Figure 1.

1.5 PHYSICAL DIMENSIONS

The physical dimensions of the connectors specified herein and the available contact arrangements are shown in Figure 2.

2 APPLICABLE DOCUMENTS

The following documents form part of this specification and shall be read in conjunction with it:

- (a) ESCC Generic Specification No. [3401](#) for Connectors, Electrical, Non-Filtered, Circular and Rectangular.
- (b) ESCC Detail Specification No. [3401/022](#), Accessories for Rectangular Connectors, [3401/001](#), [3401/002](#) and Connector Savers [3401/020](#) and [3401/080](#).
- (c) ESCC Detail Specification No. [3401/099](#), Contacts, Power, Press-fit Type for [3401/098](#) Connectors.
- (d) ESCC Basic Specification No. [20500](#), External Visual Inspection.
- (e) [MIL-DTL-24308](#), Rack and Panel Connectors, Miniature.
- (f) NASA/GSFC Specification S-311-P-10, Connectors, Electrical, Rectangular, Miniature, Polarised Shell, Rack and Panel, for Space Flight Use.
- (g) IEC 60352-5, Solderless connections – Part 5: Press-in connections – General requirements, test methods and practical guidance.

3 TERMS, DEFINITIONS, ABBREVIATIONS, SYMBOLS AND UNITS

For the purpose of this specification, the terms, definitions, abbreviations, symbols and units specified in ESCC Basic Specification No. 21300 shall apply.

TABLE 1(a) - RANGE OF COMPONENTS AND TYPE VARIANTS
VARIANTS AND SHELL SIZES

Variant	Shell Size (1)	Max. Weight (g) (2) (3)		Mating Force (N. max)	Unmating Force	
		Male	Female		N. min	N. max
01 (Gauge 20 Contacts)	E	4.5	5	30	3.5	20
	A	5.5	7	50	4.5	34
	B	9	10	83	8	55
	C	12.5	13.5	123	11	83
	D	13.5	15	166	14.5	120
02 (Gauge 22 Contacts)	E	5.2	6	46	3.4	28
	A	7.4	8	77	4.5	46
	B	11	12	127	7.9	77
	C	15.6	17	177	11.3	109
	D	18.2	20	222	14.7	136
03 (Gauge 8 Contacts)	A	6.1 (4)	7 (4)	55	4.5	44.5
		6.5 (5)	7.5 (5)	55	4.5	44.5
	B	8.6	10.1	85	8	70
	C	12	14	130	11	93

CONTACT TYPES

Contact Termination Code	Contact Type Description (6)	Maximum Weight of Contacts (g)					
		Variant 01		Variant 02		Variant 03	
		Male	Female	Male	Female	Male	Female
SND62	Gauge 20 straight press-fit contact	0.16	0.2	-	-	-	-
SDD62	Gauge 22 straight press-fit contact	-	-	0.12	0.14	-	-
SND98	Gauge 20 90° press-fit contact equipped with 90° bracket and screwlocks 4-40 (14)	-	0.23 (7) 0.29 (8) 0.34 (9)	-	-	-	-
SDD98	Gauge 22 90° press-fit contact equipped with 90° bracket and screwlocks 4-40 (14)	-	-	-	0.2 (10) 0.24 (11) 0.29 (12) 0.33 (13)	-	-
SCBM97	Gauge 8 power press-fit contact	-	-	-	-	2 (15)	1.8 (15)

NOTES:

1. See Figures 2(a) and 2(b)
2. Weights without contacts or accessories.
3. Total maximum weight, in grammes, may be calculated from:
 - connector weight.
 - contact weight for all contacts including brackets and nuts (as applicable) (see Table 1(a) Contact Types and/or the relevant Detail Specification).
 - Accessories weight given in ESCC Detail Specification No. [3401/022](#) (if applicable).
4. Weight applicable to contact arrangement 3W3. See Figure 2(b).
5. Weight applicable to contact arrangement 3WK3. See Figure 2(b).
6. See Figure 2(c)
7. Weight of contact in row nearest the connector mounting plane (Ref. Plane).
8. Weight of contact in row farthest from connector mounting plane (Ref. Plane), except for size D, where it is the middle row.
9. For size D only, weight of contact in row farthest from connector mounting plane (Ref. Plane).
10. Weight of contact in row nearest the connector mounting plane (Ref. Plane).
11. Weight of contact in row after the row specified in (10).
12. Weight of contact in row after the row specified in (11).
13. Weight of contact in row after the row specified in (12).
14. Maximum Weight of brackets and nuts:
 - Shell sizes E, A, B and C : 3.1g (Var. 01), 3.95g (Var. 02)
 - Shell size D : 3.8g (Var. 01), 4.4g (Var. 02)
15. Power contacts shall be ordered separately in accordance with ESCC Detail Specification No. [3401/099](#).

TABLE 1(b) - MAXIMUM RATINGS

No.	Characteristics	Symbol	Maximum Ratings	Unit	Remarks
1	Working Voltage (Sea Level) - Variant 01 - Variant 02 - Variant 03	U_R	300 250 250	Vrms Vrms Vrms	Note 1
2	Rated Current - Variant 01 - Variant 02 - Variant 03	I_R	7.5 3 40	A A A	-
3	Operating Temperature Range	T_{op}	-55 to +125	°C	T_{amb}
4	Storage Temperature Range	T_{stg}	-65 to +125	°C	-

NOTES:

1. Between each contact and the shell.

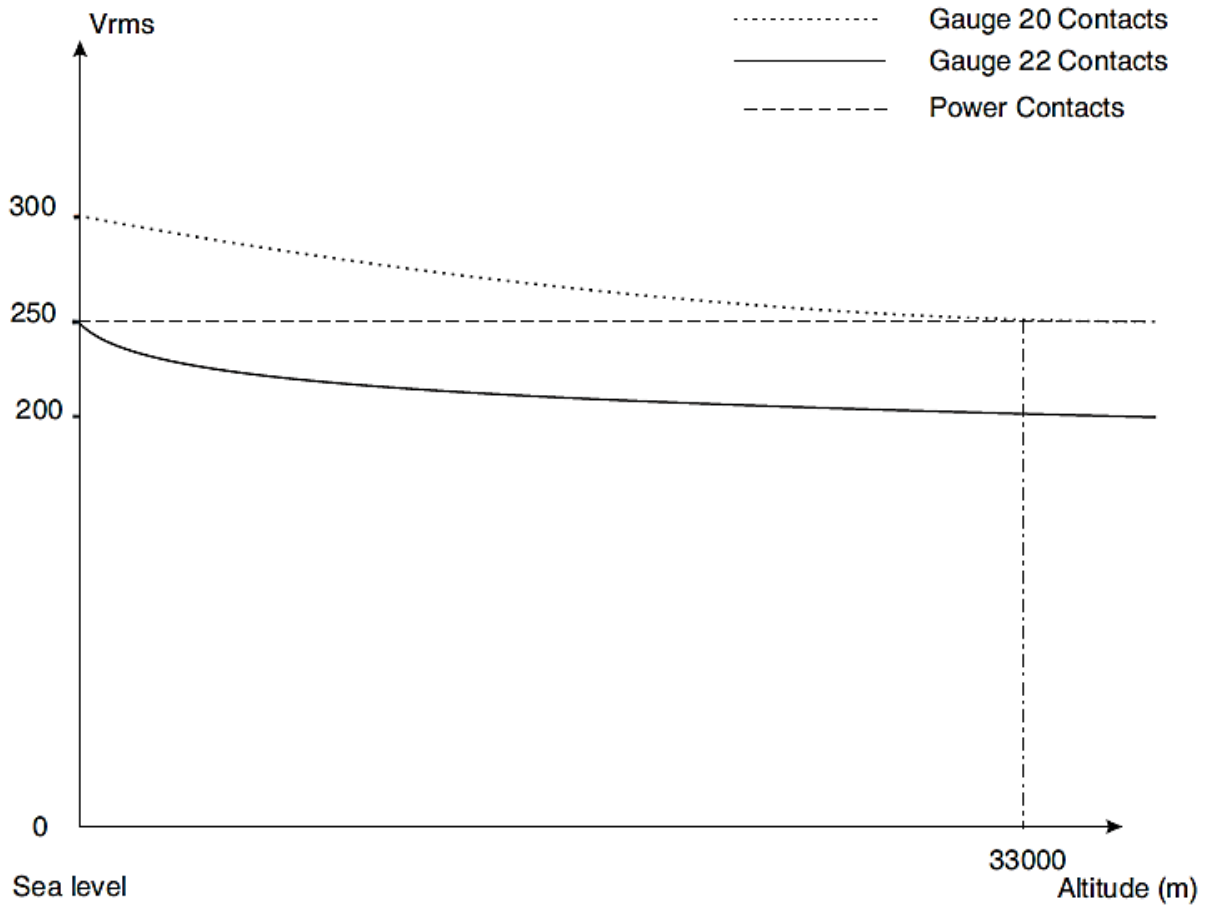
FIGURE 1 - PARAMETER DERATING INFORMATION

Working Voltage versus Altitude

FIGURE 2 - PHYSICAL DIMENSIONS

FIGURE 2(a) - RECEPTACLES AND PLUGS

VARIANTS 01 AND 02 – SHELL SIZE E

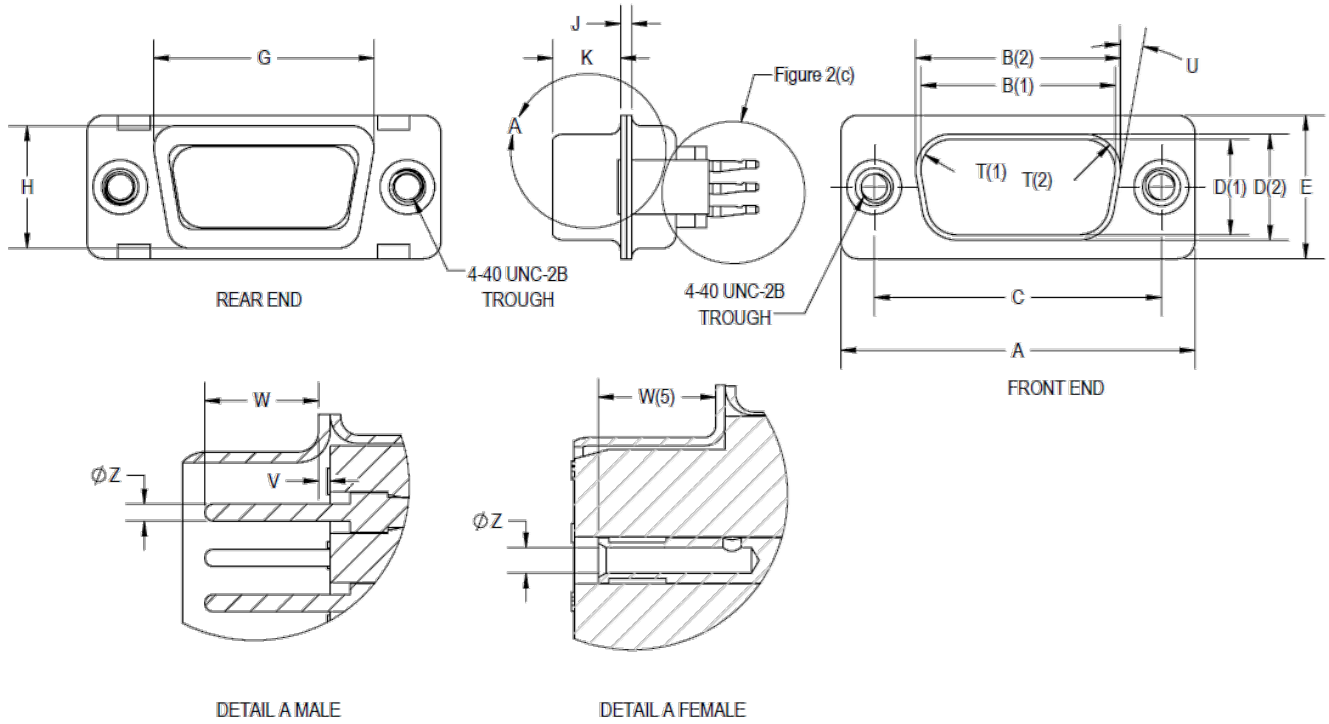

Contact Type	Connector Type	Symbol/Dim.	A	B	C	D	E	G	H	J	K	I	U °	V	W	ØZ	
																V.01	V.02
Male	Plug	Min	30.43	16.79	24.87	8.23	12.17	19.02	10.46	0.51	5.82	2.59	9	0	4.03	0.99	0.75
		Max	31.19	17.04	25.12	8.48	12.93	19.53	10.97	1.02	6.05	2.69	11	0.6	-	1.04	0.77
Female	Receptacle	Min	30.43	16.21	24.87	7.77	12.07	19.02	10.46	0.51	6.05	2.46	9	-	3.63	1.07	0.89
		Max	31.19	16.46	25.12	8.03	12.93	19.53	10.97	1.02	6.3	2.62	11	-	-	1.14	0.95

VARIANTS 01, 02 AND 03 – SHELL SIZE A

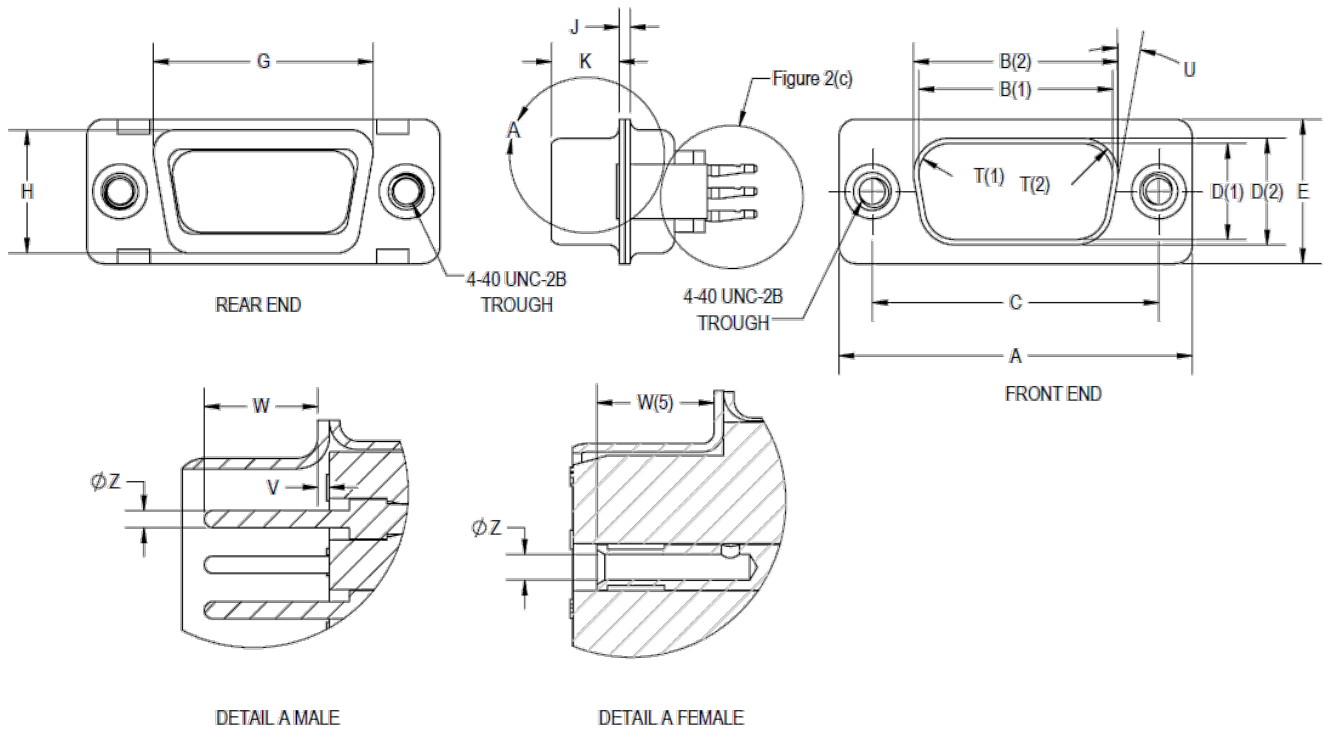

Contact Type	Connector Type	Symbol/Dim.	A	B	C	D	E	G	H	J	K	I	U °	V	W (6)	ØZ (6)	
																V.01	V.02
Male	Plug	Min	38.76	25.12	33.2	8.23	12.17	27.25	10.46	0.51	5.82	2.59	9	0	4.03	0.99	0.75
		Max	39.52	25.37	33.45	8.48	12.93	27.76	10.97	1.02	6.05	2.69	11	0.6	-	1.04	0.77
Female	Receptacle	Min	38.76	24.54	33.2	7.77	12.17	27.25	10.46	0.51	6.05	2.46	9	-	3.63	1.07	0.89
		Max	39.52	24.79	33.45	8.03	12.93	27.76	10.97	1.02	6.3	2.62	11	-	-	1.14	0.95

VARIANTS 01, 02 AND 03 – SHELL SIZE B

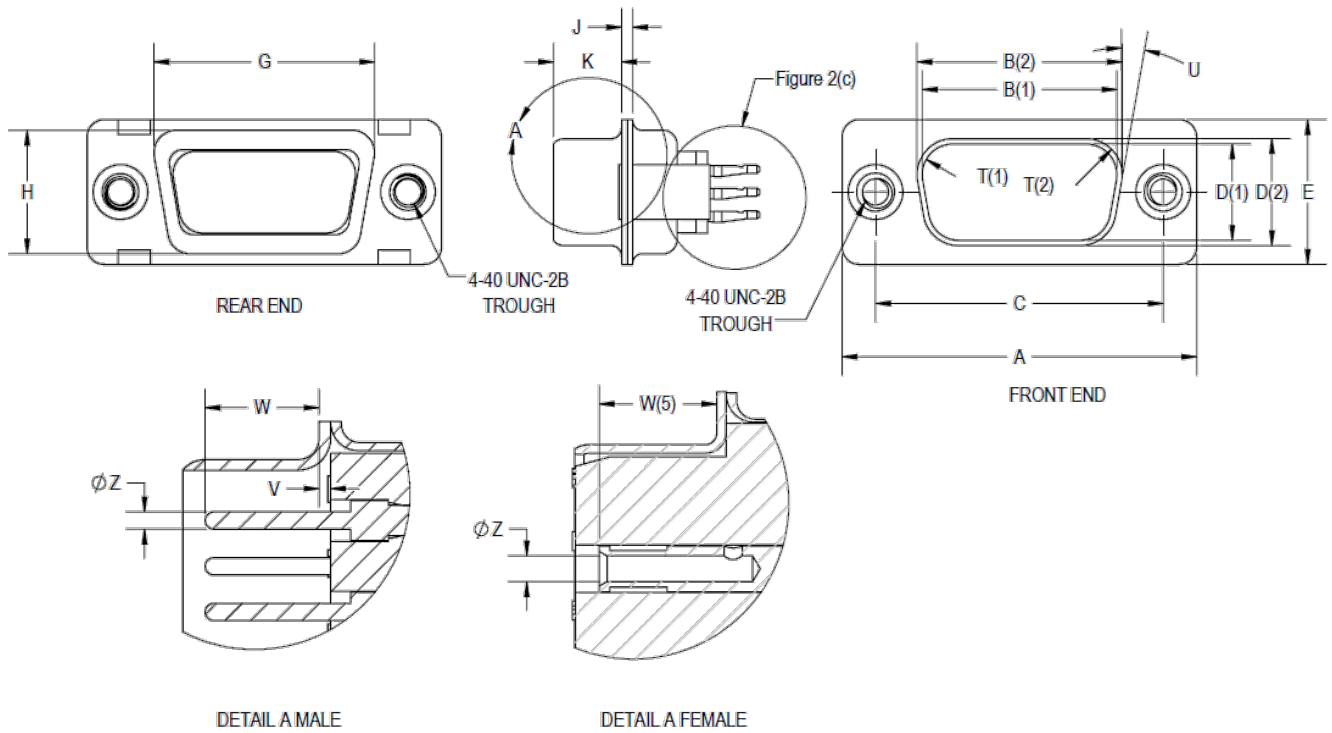

Contact Type	Connector Type	Symbol/Dim.	A	B	C	D	E	G	H	J	K	I	U	V	W (6)	ØZ (6)	
																V.01	V.02
Male	Plug	Min	52.65	38.84	46.91	8.23	12.17	41.02	10.46	0.51	5.69	2.59	9	0	4.03	0.99	0.75
		Max	53.42	39.09	47.17	8.48	12.93	41.53	10.97	1.24	5.99	2.69	11	0.6	-	1.04	0.77
Female	Receptacle	Min	52.65	38.25	46.91	7.77	12.17	41.02	10.46	0.51	6.05	2.46	9	-	3.63	1.07	0.89
		Max	53.42	38.51	47.17	8.03	12.93	41.53	10.97	1.02	6.3	2.62	11	-	-	1.14	0.95

VARIANTS 01, 02 AND 03 – SHELL SIZE C

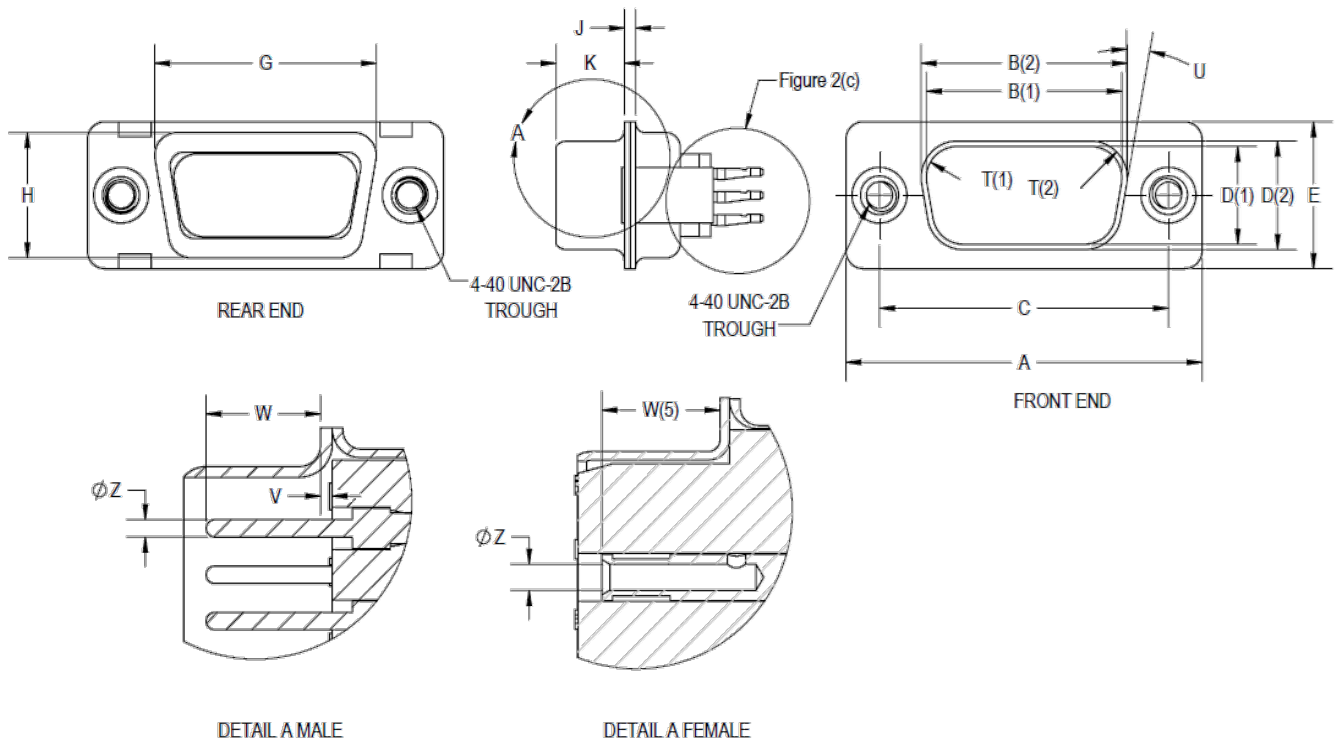

Contact Type	Connector Type	Symbol/Dim.	A	B	C	D	E	G	H	J	K	I	U °	V	W (6)	ØZ (6)	
																V.01	V.02
Male	Plug	Min	68.94	55.3	63.37	8.23	12.17	57.45	10.46	0.51	5.69	2.59	9	0	4.03	0.99	0.75
		Max	69.7	55.55	63.63	8.48	12.93	57.96	10.97	1.24	5.99	2.69	11	0.6	-	1.04	0.77
Female	Receptacle	Min	68.94	54.71	63.37	7.77	12.17	57.45	10.46	0.51	6.05	2.46	9	-	3.63	1.07	0.89
		Max	69.7	54.97	63.63	8.03	12.93	57.96	10.97	1.02	6.3	2.62	11	-	-	1.14	0.95

VARIANTS 01 AND 02 – SHELL SIZE D

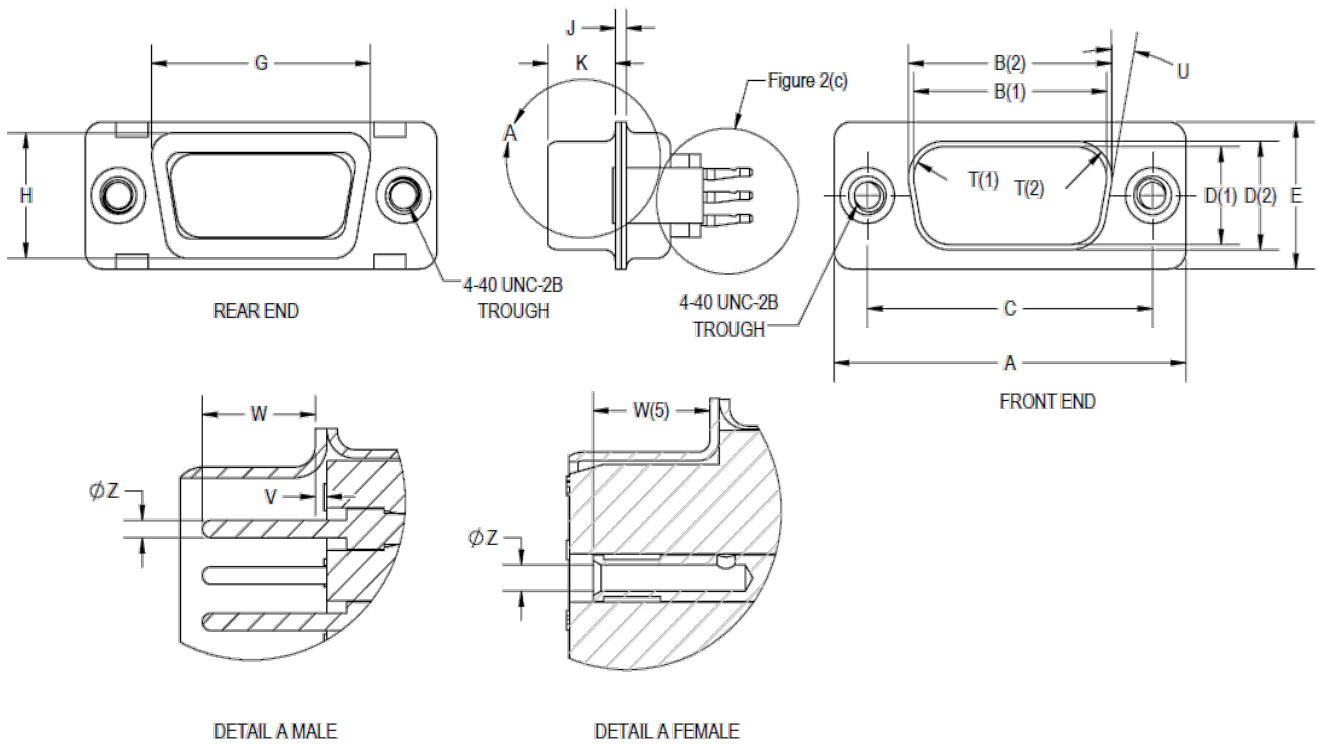

Contact Type	Connector Type	Symbol/Dim.	A	B	C	D	E	G	H	J	K	I	U	V	W	ØZ	
																V.01	V.02
Male	Plug	Min	66.55	52.68	60.99	11.07	14.99	55.07	13.31	0.51	5.69	2.59	9	0	4.03	0.99	0.75
		Max	67.31	52.93	61.24	11.33	15.75	55.58	13.82	1.24	5.99	2.69	11	0.6	-	1.04	0.77
Female	Receptacle	Min	66.55	52.3	60.99	10.62	14.99	55.07	13.31	0.51	6.05	2.46	9	-	3.63	1.07	0.89
		Max	67.31	52.55	61.24	10.87	15.75	55.58	13.82	1.02	6.3	2.62	11	-	-	1.14	0.95

NOTES TO FIGURE 2(a):

1. Inside dimension for connectors with male contacts.
2. Outside dimension for connectors with female contacts.
3. All dimensions are in millimetres (angles in degrees).
4. Underlined dimensions, in table, are critical to ensure intermateability.
5. Electrical contact position in female contact.
6. Not applicable to Variant 03.

VARIANT 03 – POWER PRESS-FIT CONTACT ARRANGEMENTS

FRONT VIEW MALE INSERT

(See Notes 1 and 2)

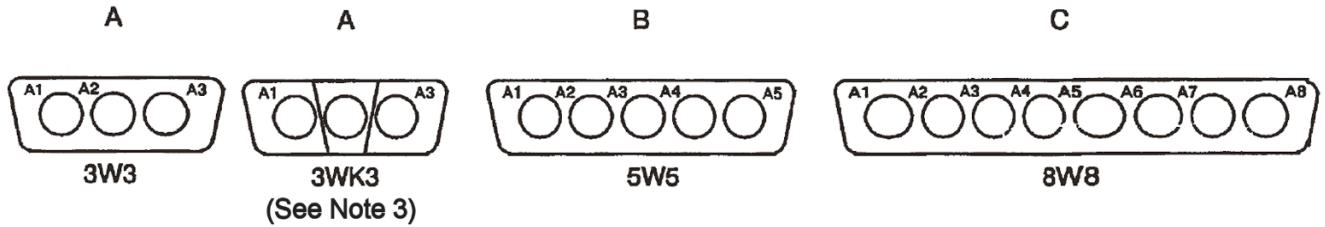

NOTES TO FIGURE 2(b):

1. Contact locations are in conformity with MIL-DTL-24308 specification sheets for signal contact arrangements and NASA/GSFC Specification S-311-P-10 for power contact arrangements, and shall not be checked during procurement.
2. The front side of the insert shall be marked with the minimum marking shown.
3. The middle part of the insulator is keyed "K", i.e. recessed or protruding, depending on the Contact Gender code. See Para. 4.5.2.1 (d) and (e).

FIGURE 2(c) - REAR END

GAUGE 20 STRAIGHT PRESS-FIT CONTACTS (CONTACT TERMINATION CODE: SND62)

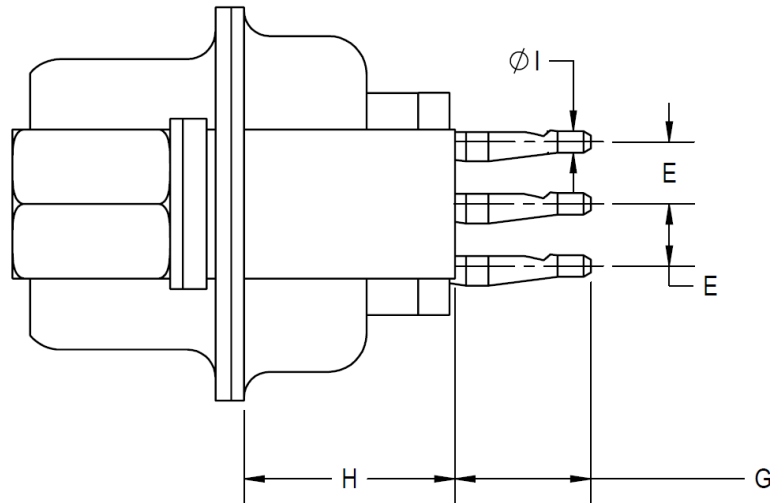

Pitch between contacts

Connector shell sizes E and A: 2.74

Connector shell sizes B, C and D: 2.76

Symbol/ Dim.	E (2)	G	H	Ø1
Min.	2.77	4	6.5	0.5
Max.	2.91	4.5	7	1

NOTES:

1. All dimensions are in mm.
2. Typical = 2.84.

GAUGE 22 STRAIGHT PRESS-FIT CONTACTS (CONTACT TERMINATION CODE: SDD62)

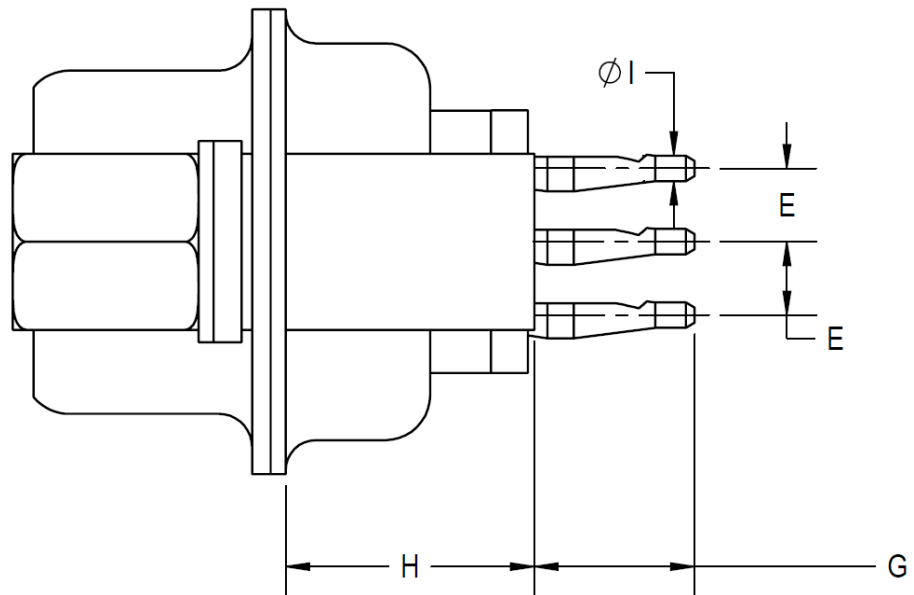

Pitch between contacts

Connector shell sizes E, A and B: 2.29

Connector shell sizes C and D: 2.41

Symbol/ Dim.	E		G	H	ØI
	Sizes E, A, B, C (2)	Size D (3)			
Min.	1.91	2.01	4	6.5	0.5
Max.	2.05	2.15	4.5	7	1

NOTES:

1. All dimensions are in mm.
2. Typical = 1.98.
3. Typical = 2.08.

GAUGE 8 POWER PRESS-FIT CONTACTS (CONTACT TERMINATION CODE: SCBM97)

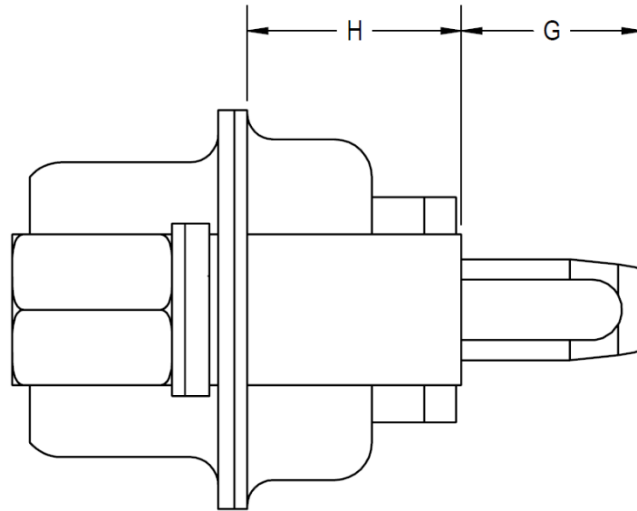

Symbol/ Dim.	G	H
Min.	4	6.5
Max.	6	7

GAUGE 20 90° PRESS-FIT CONTACTS (SIZES B AND D)
(CONTACT TERMINATION CODE: SND98)

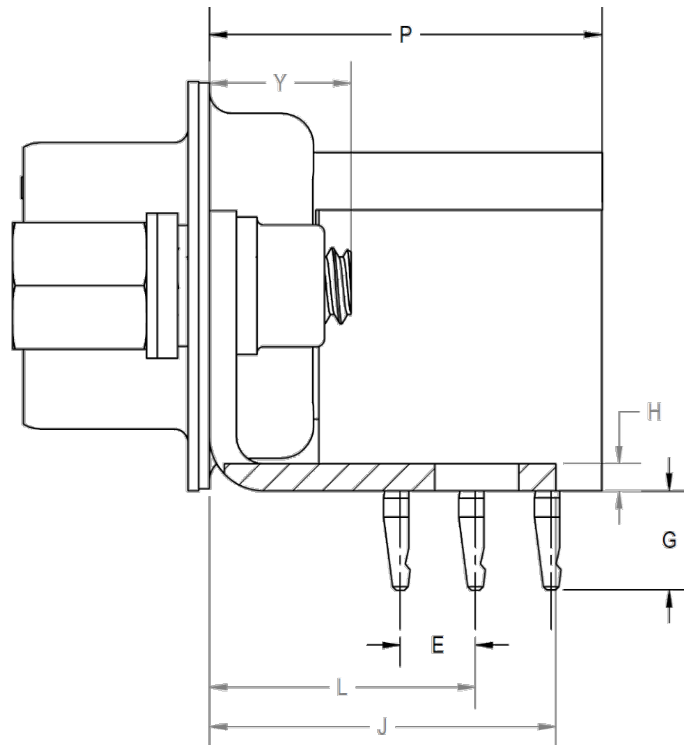

SIZE D (50 CONTACTS)

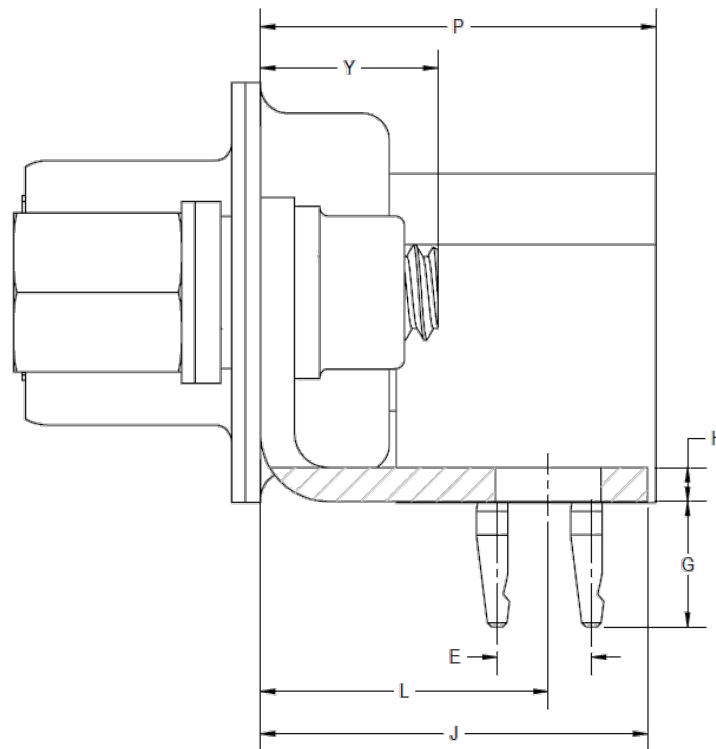

SIZE B (25 CONTACTS)

Pitch between contacts

Connector shell sizes B and D: 2.76

Symbol/ Dim.	E (2)	H	J	L		G	P	Y
				Size B	Size D			
Min.	2.79	1	-	8.54	9.96	3.5	-	-
Max.	2.89	3.2	15	8.68	10.1	4	16	7

NOTES:

1. All dimensions are in mm.
2. Typical = 2.84.

GAUGE 22 90° PRESS-FIT CONTACTS (SIZES E AND D)
(CONTACT TERMINATION CODE: SDD98)

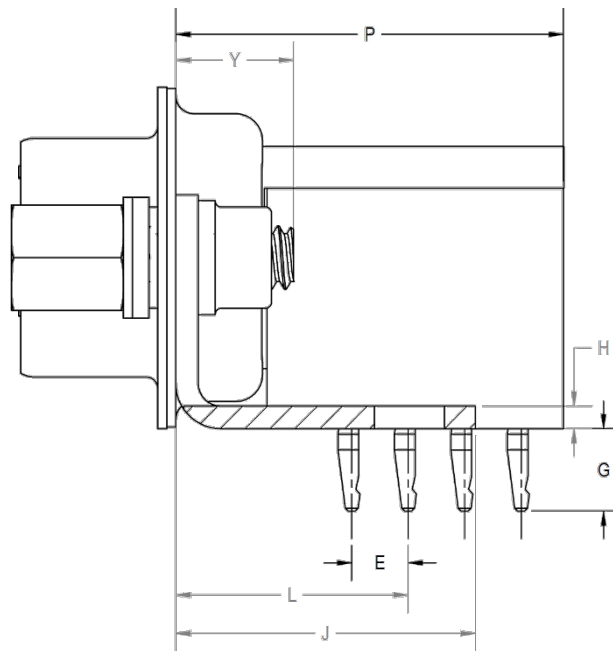

SIZE D (78 CONTACTS)

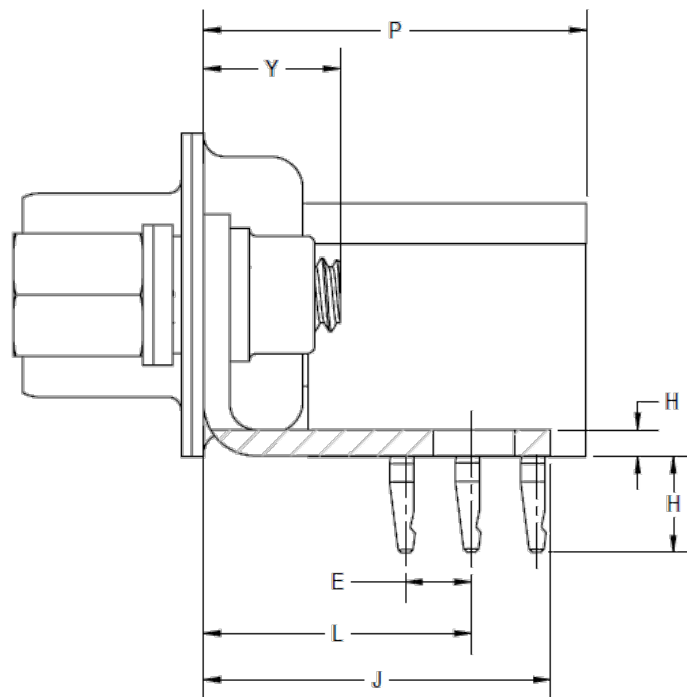

SIZE E (15 CONTACTS)

Pitch between contacts

Connector shell size E : 2.29

Connector shell size D: 2.41

Symbol/ Dim.	E (2)	H	J	L		G	P	Y
				Size E	Size D			
Min.	2.49	1	-	10.39	10.45	3.5	-	-
Max.	2.59	3.2	15	10.53	10.59	4	19	7

NOTES:

1. All dimensions are in mm.
2. Typical = 2.54.

4 REQUIREMENTS

4.1 GENERAL

The complete requirements for procurement of the connectors specified herein are stated in this specification and ESCC Generic Specification No. 3401. Deviations from the Generic Specification, applicable to this specification only, are listed in Para. 4.2.

Deviations from the applicable Generic Specification and this Detail Specification, formally agreed with specific Manufacturers on the basis that the alternative requirements are equivalent to the ESCC requirements and do not affect the components' reliability, are listed in the appendices attached to this specification.

4.2 DEVIATIONS FROM GENERIC SPECIFICATION

4.2.1 Deviations from Special In-Process Controls

None.

4.2.2 Deviations from Final Production Tests (Chart II)

(a) Para. 9.9, Seal Test: Not applicable.

4.2.3 Deviations from Burn-in and Electrical Measurements (Chart III)

None (Chart III is not applicable).

4.2.4 Deviations from Qualification Tests (Chart IV)

(a) Para. 9.9, Seal Test: Not applicable.

(b) Para. 9.10, Wiring: The following Press-Fit Insertion Force Test shall be performed in lieu of Wiring:

Choice of PCB

The PCB to be used during the press-fit insertion force test shall have the following characteristics:

- 12 layers, internal layer thickness: 17µm typical.
- PCB thickness: 2.4±1mm
- PCB material: Polyimide, suitable for space application (e.g. Arlon 35N, Arlon 85N, Ventec VT-901).
- PCB surface finish:
 - 0.05µm min. immersion gold over 4.5±1.5µm electroless nickel over 25µm min. copper
 - or
 - 15µm min. Solder (≤95% tin, remainder lead) over 25µm min. copper

Press-Fit Insertion Force Test Procedure

The connectors shall be inserted into the PCB with an insertion speed of between 25mm/minute and 50mm/minute as per IEC 60352-5, clause 5.2.2.2. The insertion forces shall be monitored and reported. The proper insertion of the press-fit terminations shall then be examined under 5× magnification in accordance with ESCC Basic Specification No. 20500.

Any plating defects shall be reported. Scratches showing any base metal are not acceptable.

The terminations shall be checked following insertion to verify they have remained straight. Burrs are not acceptable.

The connectors shall then be removed from the PCB by pushing on the termination tails with a plane surface.

The connectors shall be re-inserted, removed and then inserted once more in accordance with the procedure described above.

Final Measurements (Data Points)

For each connector, the contact resistance between the press-fit terminations and the PCB shall be measured and reported as per IEC 60352-5, clause 5.2.3.1.

- Sampling: 10% of all connector's contacts or 5 contacts, whichever is less.

(c) Para. 9.11.2, Sinusoidal Vibration:

Sweep Frequency: 5-100-5Hz. For the entire frequency range of 5 to 100Hz and return to 5Hz, the slope rate shall be 2 Octaves per minute maximum.

- Total number of Cycles: 9 (3 times in each of the 3 mutually perpendicular axes).
- Vibration Amplitude:
 - 5Hz to 26Hz: 11mm (peak)
 - 26Hz to 100Hz: 30g

(d) Para. 9.11.3, Random Vibration: The test curve shall be as follows:

Envelope: Grms = 38.5	
20 to 60 Hz	+6dB/Octave
60 to 400 Hz	2g ² /Hz
400 to 800 Hz	-6dB/Octave
800 to 1000 Hz	0.5g ² /Hz
1000 to 2000 Hz	-6dB/Octave

Duration: 180s in each of the 3 mutually perpendicular axes.

(e) Para. 9.13, Climatic Sequence: At the end of the test, the contact resistance between the press-fit terminations and the PCB shall be measured and reported as per IEC 60352-5, clause 5.2.3.1.

- Sampling: 10% of all connector's contacts or 5 contacts, whichever is less.

(f) Para 9.15, Joint Strength: Not applicable.

(g) Para. 9.16, Rapid Change of Temperature: At the end of the test, the contact resistance between the press-fit terminations and the PCB shall be measured and reported as per IEC 60352-5, clause 5.2.3.1.

- Sampling: 10% of all connector's contacts or 5 contacts, whichever is less.

The connectors shall then be removed from the PCB for the remainder of the test path.

(h) Para. 9.22, Corrosion: At the end of the test, the contact resistance between the press-fit terminations and the PCB shall be measured and reported as per IEC 60352-5, clause 5.2.3.1.

- Sampling: 10% of all connector's contacts or 5 contacts, whichever is less.

(i) Para. 9.24, Jackscrew Retention: Not applicable.

(j) Para. 9.31, Solderability: Not applicable.

4.2.5 Deviations from Lot Acceptance Tests (Chart V)

(a) Para. 9.9, Seal Test: Not applicable.

(b) Para. 9.10, Wiring: The following Press-Fit Insertion Force Test shall be performed in lieu of Wiring:

Choice of PCB

The PCB to be used during the press-fit insertion force test shall have the following characteristics:

- 12 layers, internal layer thickness: 17µm typical.
- PCB thickness: 2.4±1mm
- PCB material: Polyimide, suitable for space application (e.g. Arlon 35N, Arlon 85N, Ventec VT-901).
- PCB surface finish:
 - 0.05µm min. immersion gold over 4.5±1.5µm electroless nickel over 25µm min. copper
 - or
 - 15µm min. Solder (≤95% tin, remainder lead) over 25µm min. copper

Press-Fit Insertion Force Test Procedure

The connectors shall be inserted into the PCB with an insertion speed of between 25mm/minute and 50mm/minute as per IEC 60352-5, clause 5.2.2.2. The insertion forces shall be monitored and reported. The proper insertion of the press-fit terminations shall then be examined under 5× magnification in accordance with ESCC Basic Specification No. [20500](#).

Any plating defects shall be reported. Scratches showing any base metal are not acceptable.

The terminations shall be checked following insertion to verify they have remained straight. Burrs are not acceptable.

The connectors shall then be removed from the PCB by pushing on the termination tails with a plane surface.

The connectors shall be re-inserted, removed and then inserted once more in accordance with the procedure described above.

Final Measurements (Data Points)

For each connector, the contact resistance between the press-fit terminations and the PCB shall be measured and reported as per IEC 60352-5, clause 5.2.3.1.

- Sampling: 10% of all connector's contacts or 5 contacts, whichever is less.

(c) Para. 9.13, Climatic Sequence: At the end of the test, the contact resistance between the press-fit terminations and the PCB shall be measured and reported as per IEC 60352-5, clause 5.2.3.1.

- Sampling: 10% of all connector's contacts or 5 contacts, whichever is less.

(d) Para 9.15, Joint Strength: Not applicable.

(e) Para. 9.16, Rapid Change of Temperature: At the end of the test, the contact resistance between the press-fit terminations and the PCB shall be measured and reported as per IEC 60352-5, clause 5.2.3.1.

- Sampling: 10% of all connector's contacts or 5 contacts, whichever is less.

The connectors shall then be removed from the PCB for the remainder of the test path.

(f) Para. 9.22, Corrosion: At the end of the test, the contact resistance between the press-fit terminations and the PCB shall be measured and reported as per IEC 60352-5, clause 5.2.3.1.

- Sampling: 10% of all connector's contacts or 5 contacts, whichever is less.

4.3 MECHANICAL REQUIREMENTS

4.3.1 Dimension Check

The dimensions of the connectors specified herein shall be verified in accordance with the requirements set out in Para. 9.6 of ESCC Generic Specification [3401](#) and shall conform to those shown in Figure 2 of this specification. Only the underlined dimensions shall be checked during procurement.

4.3.2 Weight

The maximum weight of the connectors specified herein, with contacts where applicable, shall be as specified in Table 1(a).

4.3.3 Contact Capability

For the purpose of this test, the pick-up and drop weights shall be as follows:

Contacts	Measurements	Pick-Up Weight	Drop Weight
Gauge 20	Weight (g)	28.35	226.8
	Pin diameter (mm)	0.99 to 0.993	1.039 to 1.04
	Insertion depth (mm)	4	4
Gauge 22	Weight (g)	19.84	226.8
	Pin diameter (mm)	0.749 to 0.751	0.773 to 0.775
	Insertion depth (mm)	4	4

See ESCC Detail Specification No. [3401/099](#) for power contacts.

4.3.4 Contact Retention (in insert)

For gauge 20 and 22 contacts the contact retention force shall be 40N.

See ESCC Detail Specification No. [3401/099](#) for power contacts.

4.3.5 Mating and Unmating Forces

The forces applied for mating and unmating of the connectors shall conform to the values specified in Table 1(a).

4.3.6 Insert Retention (in Shell)

Connector inserts shall withstand a pressure of 42.8N/cm² without being dislodged from the shell.

4.3.7 Contact Insertion and Withdrawal Forces

See ESCC Detail Specification No. [3401/099](#) for power contacts. Not applicable to other contact types.

4.3.8 Engagement and Separation Forces

The engagement and separation forces of the female contacts shall be tested with the applicable test pin and shall not exceed the values of the table hereunder.

Contacts	Measurements	Diameter (mm)		Engagement Max (N)	Separation (N)	
		Min	Max		Min	Max
Gauge 20	Max Ø Test Pin	1.039	1.04	3.33	-	2.22
	Min Ø Test Pin	0.99	0.993	-	0.28	-
Gauge 22	Max Ø Test Pin	0.773	0.775	3.33	-	2.22
	Min Ø Test Pin	0.749	0.751	-	0.2	-

See ESCC Detail Specification No. [3401/099](#) for power contacts.

4.3.9 Oversize Pin Exclusion

The diameter of the test pin and the force applied to it shall be as follows:

Contacts	Test Pin Diameter (mm)		Force (N) Max
	Min	Max	
Gauge 20	1.166	1.17	3.33
Gauge 22	0.905	0.907	2.43

See ESCC Detail Specification No. [3401/099](#) for power contacts.

4.3.10 Probe Damage

The probe diameter and the moment at the end of the probe shall be as follows:

Contacts	Probe Diameter (mm)		Moment (N.cm)
	Min	Max	
Gauge 20	1.007	1.033	5.65
Gauge 22	0.749	0.774	1.3

See ESCC Detail Specification No. [3401/099](#) for power contacts.

4.3.11 Press-fit Insertion Force

Receiving holes for press-fit terminations and the insertion force shall be as follows:

Contacts	Receiving Hole Diameter (mm)		Max. Insertion Force (N)
	Min.	Max.	
Gauge 20	1.04	1.14	50
Gauge 22	1.04	1.14	50

See ESCC Detail Specification No. [3401/099](#) for power contacts.

4.4 MATERIALS AND FINISHES

The materials and finishes shall be as specified herein. Where a definite material is not specified, a material which will enable the connectors specified herein to meet the performance requirements of this specification shall be used. Acceptance or approval of any constituent material does not guarantee acceptance of the finished product.

4.4.1 Shells

Shells shall be made of brass. The plating shall be 1.27µm minimum of gold over 1µm minimum of copper or 12.7µm minimum of electroless nickel.

4.4.2 Inserts, Additional Spacing Insert

Inserts shall be made of glass-fibre filled diallylphthalate resin or a suitable thermoplastic material.

For Variant 03 the additional spacing insert, which provides the required increased insulation, shall be made of a suitable thermoplastic material.

4.4.3 Contacts

The contact body shall be made of copper alloy with an underplate of 1µm minimum of copper, gold plated with 1.27µm minimum of gold.

The female contact spring element shall be made of copper alloy with an underplate of 1µm minimum of nickel or copper, gold plated with 1.27µm minimum of gold.

4.4.4 Contact Retaining Clip

Not applicable to gauge 20 and 22 contacts.

See ESCC Detail Specification No. [3401/099](#) for power contacts.

4.4.5 Guiding and Locking Devices

As specified in ESCC Detail Specification No. [3401/022](#).

4.4.6 Magnetism Level

The allowable value of magnetism shall not exceed that specified for the relevant level (see Para. 4.5.2.1 (f)). Only magnetism levels NMC and NMD are verified.

4.5 MARKING

4.5.1 General

The marking of all components delivered to this specification shall be in accordance with the requirements of ESCC Basic Specification No. [21700](#) and the following paragraphs.

Each component or the component's primary package shall be marked in respect of:

- (a) The ESCC qualified components symbol (for ESCC qualified components only).
- (b) Contact Identification Numbering (see Figure 2(b)).
- (c) The ESCC Component Number (see Para. 4.5.2).
- (d) Traceability information.

4.5.2 The ESCC Component Number

The ESCC Component Number shall be constituted as follows:

Example: 340109801BDEM9SNMBSND62A175

- Detail Specification Reference: 3401098
- Component Type Variant Number: 01 (as required; see Table 1(a))
- Testing Level: B (mandatory)
- Characteristic code: Series: D (mandatory)
- Characteristic code: Shell Size: E (as required)
- Characteristic code: Insert Type: M (mandatory)
- Characteristic code: Contact Arrangement: 9 (as required)
- Characteristic code: Contact Gender: S (female)
- Characteristic code: Magnetism Level: NMB (200 gamma)
- Characteristic code: Contact Termination Code: SND62 (as required)
- Characteristic code: Modification Code: A175 (if/when required)

4.5.2.1 *Characteristics Codes*

Characteristics to be codified as part of the ESCC Component Number shall be as follows:

- (a) **Series**
The connector series shall be indicated by the code letter “D”.
- (b) **Shell Size**
The shell size shall be indicated by the following code letters: E, A, B, C, D. See Table 1(a).
- (c) **Insert Type**
The type of insert shall be indicated by the code letter “M”.
- (d) **Contact Arrangement**
The contact arrangement shall be indicated by the following codes:

Code	Shell Size	Number of Contacts Gauge 20 (where applicable)	Number of Contacts Gauge 22 (where applicable)	Number of Power Contact Cavities (where applicable) (Note 1)
9	E	9	0	0
15	A	15	0	0
15	E	0	15	0
3W3	A	0	0	3
3WK3	A	0	0	3 (2)
25	B	25	0	0
26	A	0	26	0
5W5	B	0	0	5
37	C	37	0	0
8W8	C	0	0	8
44	B	0	44	0
50	D	50	0	0
62	C	0	62	0
78	D	0	78	0

NOTES:

1. For Variant 03 the power contacts shall be ordered separately in accordance with ESCC Detail Specification No. [3401/099](#).
Power contacts must be from the same Manufacturer as the connector in which they are mounted, and this shall be verified prior to assembly.
2. Either 2 male contacts plus 1 female contact, or 2 female contacts plus 1 male contact (see below).

(e) Contact Gender

The gender of the contacts shall be indicated by the following code letters:

Code Letter	Contact Gender
P	Male
S	Female

For Contact Arrangement Code 3WK3, the gender of the contacts installed in cavities A1 and A3 (see Figure 2(b)) shall determine the code letter to be used.

(f) Magnetism Level

The following codes shall be used for magnetism level.

Code	Definition
NMB	Magnetism Level: ≤ 200 gamma (1)
NMC	Magnetism Level: ≤ 20 gamma
NMD	Magnetism Level: ≤ 2 gamma

NOTES:

1. Guaranteed, but not measured.

(g) Contact Termination Code

The contact termination codes are indicated the Contact Types table (see Table 1(a)).

(h) Modification Code

The modification code for the electroless nickel finish shall be A175.

4.5.3 Traceability Information

Traceability information shall be marked in accordance with the requirements of ESCC Basic Specification No. [21700](#).

4.6 ELECTRICAL MEASUREMENTS

4.6.1 Electrical Measurements at Room Temperature

The parameters to be measured in respect of electrical characteristics are scheduled in Table 2. Unless otherwise specified, these measurements shall be performed at $T_{amb} = +22 \pm 3^{\circ}C$.

TABLE 2 - ELECTRICAL MEASUREMENTS AT ROOM TEMPERATURE

No.	Characteristic	Symbol	ESCC 3401 Test Method and Test Conditions	Limits		Unit
				Min	Max	
1	Insulation Resistance	R _I	Para. 9.1.1.1	5000	-	MΩ
2	Voltage Proof Leakage Current - Variant 01 - Variants 02, 03	I _L	Para. 9.1.1.2 1250Vrms 1000Vrms	- -	2 2	mA
3	Low Level Contact Resistance - Gauge 20 Signal Contacts - Gauge 22 Signal Contacts - Power Contacts	R _{CL}	Para. 9.1.1.3	- - -	6 12 Note 1	mΩ
4	Rated Current Contact Resistance - Gauge 20 Signal Contacts - Gauge 22 Signal Contacts - Power Contacts	R _{CR}	Para. 9.1.1.3 7.5A 3A Note 1	- - -	5 10 Note 1	mΩ

NOTES:

1. See ESCC Detail Specification No. [3401/099](#) for power contacts.

4.7 ENVIRONMENTAL AND ENDURANCE TESTS (CHARTS IV AND V OF ESCC GENERIC SPECIFICATION No. [3401](#))

4.7.1 Measurements and Inspections on Completion of Environmental Tests

The parameters to be measured and inspections to be performed on completion of environmental testing shall be those specified in Table 6. Unless otherwise specified, the measurements shall be performed at T_{amb} = +22 ±3°C.

4.7.2 Measurements and Inspections on Completion of Endurance Tests

The parameters to be measured and inspections to be performed on completion of endurance tests shall be those specified in Table 6. Unless otherwise specified, the measurements shall be performed at T_{amb}, = +22 ±3°C.

4.7.3 Conditions for High Temperature Storage Test (Part of Endurance Testing)

The requirements for the high temperature storage test are specified in Section 9 of ESCC Generic Specification No. [3401](#). The conditions for high temperature storage testing shall be the maximum storage temperature specified in Table 1(b) of this specification.

TABLE 6 - MEASUREMENTS AND INSPECTIONS ON COMPLETION OF ENVIRONMENTAL AND ENDURANCE TESTING

No.	ESCC Generic Spec. No. 3401		Measurements and Inspections		Symbol	Limits		Unit
	Environmental and Endurance Tests (1)	Test Method and Conditions	Identification	Conditions		Min	Max	
01	Wiring	Paras. 4.2.4, 4.2.5 and 4.3.11 of this Spec.	Press-fit Insertion Force	Para. 4.3.11 of this Spec.	-	Para. 4.3.11 of this Spec.		-
			Final Measurements					
			Low Level Contact Resistance	Table 2 Item 3	R _{CL}	Table 2 Item 3	mΩ	
			Rated Current Contact Resistance	Table 2 Item 4	R _{CR}	Table 2 Item 4	mΩ	
02	Vibration	Para. 9.11 and Para. 4.2.4 of this Spec.	Initial Measurements			Record Values		
			Coupling Screw(s) Unlocking Torque	-	-			
			Final Measurements	Full Engagement				
			Coupling Screw(s) Unlocking Torque Drift	-	Δ	-25	+25	%
			Visual Examination	-	-	-	-	
03	Shock or Bump	Para. 9.12	Final Measurements	Full Engagement				
			Visual Examination	-	-	-	-	
04	Climatic Sequence	Para. 9.13 and Paras. 4.2.4 and 4.2.5 of this Spec.	Dry Heat					
			Insulation Resistance	At high temperature Table 2 Item 1	R _i	1000	-	MΩ
			Low Air Pressure					
			Voltage Proof Leakage Current	Figure 1	I _L	Table 2 Item 2		mA
			Damp Heat					
			Insulation Resistance	Immediately after test Table 2 Item 1	R _i	100	-	MΩ
			Final Measurements	After 1 - 24hrs Recovery				
External Visual Inspection	ESCC 3401 Para. 9.7	-	ESCC 3401 Para. 9.7					
			Insulation Resistance	Table 2 Item 1	R _i	Table 2 Item 1	MΩ	
			Voltage Proof Leakage Current	Table 2 Item 2	I _L	Table 2 Item 2	mA	
05	Plating Thickness	Para. 9.14	Thickness	-	-	Para. 4.4.3 of this Spec.		
06	Rapid Change of Temperature	Para. 9.16 and Paras. 4.2.4 and 4.2.5 of this Spec.	Visual Examination	-	-	-	-	
			Insulation Resistance	Table 2 Item 1	R _i	Table 2 Item 1		MΩ
			Voltage Proof Leakage Current	Table 2 Item 2	I _L	Table 2 Item 2		mA
07	Contact Retention (In Insert)	Para. 9.17 and Para. 4.3.4 of this spec	Contact Displacement	-	-	ESCC 3401 Para. 9.17		

No.	ESCC Generic Spec. No. 3401		Measurements and Inspections		Symbol	Limits		Unit
	Environmental and Endurance Tests (1)	Test Method and Conditions	Identification	Conditions		Min	Max	
08	Endurance	Para. 9.18	Initial Measurements					
			Mating/Unmating Forces	-	F	Para. 4.3.5 of this Spec.	N	
			Low Level Contact Resistance	Table 2 Item 3	R _{CL}	Record Values	mΩ	
			Final Measurements					
			Visual Examination	-	-	-	-	
			Mating/Unmating Forces	-	F	Para. 4.3.5 of this Spec.	N	
			Low Level Contact Resistance Drift	Table 2 Item 3	ΔR _{CL}	-	3	mΩ
			Insulation Resistance	Table 2 Item 1	R _I	Table 2 Item 1	MΩ	
			Voltage Proof Leakage Current	Table 2 Item 2	I _L	Table 2 Item 2	mA	
09	Permanence of Marking	Para. 9.19	As applicable	-	-	-	-	-
10	Mating and Unmating Forces	Para. 9.20	Force	-	F	Para. 4.3.5 of this Spec.	N	
11	High Temperature Storage	Para. 9.21	Initial Measurements					
			Low Level Contact Resistance	Table 2 Item 3	R _{CL}	Record Values	mΩ	
			Final Measurements					
			Visual Examination	-	-	-	-	
			Mating/Unmating Forces	-	F	Para. 4.3.5 of this Spec.	N	
			Low Level Contact Resistance Drift	Table 2 Item 3	ΔR _{CL}	-	3	mΩ
			Rated Current Contact Resistance	Table 2 Item 4	R _{CR}	Table 2 Item 4	mΩ	
			Insulation Resistance	Table 2 Item 1	R _I	Table 2 Item 1	MΩ	
			Voltage Proof Leakage Current	Table 2 Item 2	I _L	Table 2 Item 2	mA	
			Contact Retention (In Insert)	Para. 4.3.4 of this Spec.	-	ESCC 3401 Para. 9.17	N	
12	Corrosion	Para. 9.22 and Paras. 4.2.4 and 4.2.5 of this Spec.	Visual Examination	-	-	-	-	-
13	Insert Retention (In Shell)	Para. 9.23 and Para. 4.3.6 of this Spec.	Visual Examination	-	-	Para. 4.3.6 of this Spec.	-	
14	High Temperature Measurements	Para. 9.25	Insulation Resistance	Table 2 Item 1	R _I	500	-	MΩ

No.	ESCC Generic Spec. No. 3401		Measurements and Inspections		Symbol	Limits		Unit
	Environmental and Endurance Tests (1)	Test Method and Conditions	Identification	Conditions		Min	Max	
15	Overload Test	Para. 9.26	Internal Temperature	-	T	-	+100	°C
			Rated Current Contact Resistance	Table 2 Item 4	R _{CR}	Table 2 Item 4		mΩ
			Insulation Resistance	Table 2 Item 1	R _I	Table 2 Item 1		MΩ
			Voltage Proof Leakage Current	Table 2 Item 2	I _L	Table 2 Item 2		mA
16	Maintenance Ageing	Para. 9.27	Visual Examination	-	-	-	-	-
			Contact Retention	Para. 4.3.4 of this Spec.	-	ESCC 3401 Para. 9.17		N
			Contact Insertion & Withdrawal Forces	Para. 4.3.7 of this Spec.	F	Para. 4.3.7 of this Spec.		N
17	Engagement and Separation Forces	Para. 9.28 and Para. 4.3.8 of this Spec.	Force	-	F	Para. 4.3.8 of this Spec.		-
18	Oversize Pin Exclusion	Para. 9.29 and Para. 4.3.9 of this Spec.	-	-	-	ESCC 3401 Para. 9.29		-
19	Probe Damage	Para. 9.30 and Para. 4.3.10 of this Spec.	Contact Separation Force	Para. 4.3.8 of this Spec.	F	Para. 4.3.8 of this Spec.		-

NOTES:

1. The tests in this table refer to either Chart IV or V and shall be used as applicable.