



**CAPACITORS, FIXED, SELF-HEALING,  
NON-INDUCTIVE,  
POLYETHYLENE TEREPHTALATE DIELECTRIC**

**BASED ON TYPE PM948S**

**ESCC Detail Specification No. 3006/026**

Issue 5	April 2023
---------	------------



**LEGAL DISCLAIMER AND COPYRIGHT**

European Space Agency, Copyright © 2023. All rights reserved.

The European Space Agency disclaims any liability or responsibility, to any person or entity, with respect to any loss or damage caused, or alleged to be caused, directly or indirectly by the use and application of this ESCC publication.

This publication, without the prior permission of the European Space Agency and provided that it is not used for a commercial purpose, may be:

- copied in whole, in any medium, without alteration or modification.
- copied in part, in any medium, provided that the ESCC document identification, comprising the ESCC symbol, document number and document issue, is removed.

**DOCUMENTATION CHANGE NOTICE**

(Refer to <https://escies.org> for ESCC DCR content)

DCR No.	CHANGE DESCRIPTION
<a href="#">1521</a> , <a href="#">1522</a> , <a href="#">1555</a> , <a href="#">1558</a> , <a href="#">1565</a>	Specification updated to incorporate changes per DCR.

**TABLE OF CONTENTS**

1	GENERAL	5
1.1	SCOPE	5
1.2	APPLICABLE DOCUMENTS	5
1.3	TERMS, DEFINITIONS, ABBREVIATIONS, SYMBOLS AND UNITS	5
1.4	THE ESCC COMPONENT NUMBER AND COMPONENT TYPE VARIANTS	5
1.4.1	The ESCC Component Number	5
1.4.1.1	Characteristics and Ratings Codes	5
1.4.2	Component Type Variants and Range of Components	6
1.4.2.1	Component Type Variants	6
1.4.2.2	Range of Components	6
1.5	MAXIMUM RATINGS	16
1.6	PHYSICAL DIMENSIONS AND TERMINAL IDENTIFICATION	17
1.6.1	Component Type Variants 01 to 04 (PM948S)	17
1.6.2	Component Type Variants 05 to 08 (PM948NS)	18
1.7	FUNCTIONAL DIAGRAM	18
1.8	MATERIALS AND FINISHES	19
1.8.1	Lead/Terminal Material	19
1.8.2	Lead/Terminal Finish	19
2	REQUIREMENTS	19
2.1	GENERAL	19
2.1.1	Deviations from the Generic Specification	19
2.1.1.1	Deviations from Qualification and Periodic Tests – Chart F4	19
2.2	MARKING	20
2.3	ROBUSTNESS OF TERMINATIONS	20
2.4	ELECTRICAL MEASUREMENTS AT ROOM, HIGH AND LOW TEMPERATURES	20
2.4.1	Room Temperature Electrical Measurements	20
2.4.2	High and Low Temperatures Electrical Measurements	21
2.5	INTERMEDIATE AND END-POINT ELECTRICAL MEASUREMENTS	21
2.6	BURN-IN CONDITIONS	23
	APPENDIX 'A'	24

**1 GENERAL**

**1.1 SCOPE**

This specification details the ratings, physical and electrical characteristics, and test and inspection data for the component type variants and/or the Component Type Variants and Range of Components specified below. It supplements the requirements of, and shall be read in conjunction with, the ESCC Generic Specification listed under Applicable Documents.

**1.2 APPLICABLE DOCUMENTS**

The following documents form part of this specification and shall be read in conjunction with it:

- (a) ESCC Generic Specification No. [3006](#).

**1.3 TERMS, DEFINITIONS, ABBREVIATIONS, SYMBOLS AND UNITS**

For the purpose of this specification, the terms, definitions, abbreviations, symbols and units specified in ESCC Basic Specification No. [21300](#) shall apply.

**1.4 THE ESCC COMPONENT NUMBER AND COMPONENT TYPE VARIANTS**

**1.4.1 The ESCC Component Number**

The ESCC Component Number shall be constituted as follows:

Example: 300602603155KH

- Detail Specification Reference: 3006026
- Component Type Variant Number: 03 (as required)
- Characteristic code: Capacitance Value (1.5µF): 155 (as required)
- Characteristic code: Capacitance Tolerance (±10%): K (as required)
- Rating code: Rated Voltage (250V): H (as required)

**1.4.1.1 Characteristics and Ratings Codes**

Characteristics and ratings to be codified as part of the ESCC Component Number shall be as follows:

- (a) Capacitance Value, C, expressed by means of the following codes in accordance with ESCC Basic Specification No. [21700](#). The unit quantity shall be picofarads (pF).

Capacitance Value C (pF)	Code
XX 10 <sup>3</sup>	XX3
XX 10 <sup>4</sup>	XX4
XX 10 <sup>5</sup>	XX5
XX 10 <sup>6</sup>	XX6

- (b) Capacitance Tolerance expressed by the following codes in accordance with ESCC Basic Specification No. [21700](#):

Tolerance (± %)	Code Letter
10	K
20	M

(c) DC Rated Voltage,  $U_R$ , expressed by the following codes:

DC Rated Voltage $U_R$ (V)	Code Letter
50	C
63	D
100	E
170	F
200	G
250	H
400	K
500	L
630	Z

1.4.2 Component Type Variants and Range of Components

1.4.2.1 *Component Type Variants*

Eight Component Type Variants are defined in this specification and four different package types are available, as follows:

- Surface mount package: Component Type Variants 01 to 04
- Plug-in package with two rows of 4 terminals: Component Type Variants 05 and 06
- Plug-in package with two rows of 5 terminals: Component Type Variant 07
- Plug-in package with two rows of 6 terminals: Component Type Variant 08

One, two or four different sizes are therefore available for each package type. See Para. 1.6 for details.

1.4.2.2 *Range of Components*

The range of components applicable to this specification are as follows:

DC Rated Voltage ( $U_R$ ) Max (V) (Note 1)	Capacitance Value C ( $\mu$ F) (Note 2)	AC Rated Current ( $I_{RA}$ ) Max (Arms)	Available Type Variants (See Para. 1.6) (Note 1)	Dimension B Max (mm) (See Para. 1.6)	Weight Max (g)
50	2.2	1.3	01, 05	6	1
50	2.7	1.6	01, 05	6	1
50	3.3	1.9	01, 05	6	1
50	3.9	2.3	01, 05	8	1.3
50	4.7	2.8	01, 05	8	1.3
50	4.7	1.4	02, 06	6	1.6
50	5.6	3.3	01, 05	10	1.7
50	5.6	1.7	02, 06	6	1.6
50	6.8	4.1	01, 05	10	1.7
50	6.8	2.1	02, 06	6	1.6
50	6.8	1.9	03, 07	6	2.2
50	8.2	4.9	01, 05	12	2
50	8.2	2.5	02, 06	8	2.1

DC Rated Voltage ( $U_R$ ) Max (V) (Note 1)	Capacitance Value C ( $\mu$ F) (Note 2)	AC Rated Current ( $I_{RA}$ ) Max (Arms)	Available Type Variants (See Para. 1.6) (Note 1)	Dimension B Max (mm) (See Para. 1.6)	Weight Max (g)
50	8.2	2.3	03, 07	6	2.2
50	10	6	01, 05	12	2
50	10	3.1	02, 06	8	2.1
50	10	2.9	03, 07	6	2.2
50	10	2.6	04, 08	6	2.7
50	12	3.7	02, 06	8	2.1
50	12	3.4	03, 07	6	2.2
50	12	3.1	04, 08	6	2.7
50	15	4.6	02, 06	10	2.6
50	15	4.3	03, 07	8	3
50	15	3.9	04, 08	6	2.7
50	18	5.2	03, 07	8	3
50	18	4.6	04, 08	8	3.6
50	22	6.3	03, 07	10	3.7
50	22	5.7	04, 08	8	3.6
50	27	7.8	03, 07	12	4.7
50	27	7	04, 08	10	4.6
50	33	9.5	03, 07	14	5.2
50	33	8.5	04, 08	12	5.5
50	39	1	04, 08	15	6.8
50	47	12.2	04, 08	15	6.8
63	1	1.4	01, 05	6	1
63	1.2	1.5	01, 05	6	1
63	1.5	1.9	01, 05	6	1
63	1.8	2	01, 05	6	1
63	2.2	2.5	01, 05	8	1.3
63	2.2	1.7	02, 06	6	1.6
63	2.7	2.9	01, 05	8	1.3
63	2.7	1.8	02, 06	6	1.6
63	3.3	3.3	01, 05	10	1.7
63	3.3	2.2	02, 06	6	1.6
63	3.3	2.2	03, 07	6	2.2
63	3.9	3.5	01, 05	10	1.7
63	3.9	2.3	02, 06	6	1.6
63	3.9	2.4	03, 07	6	2.2
63	4.7	3.9	01, 05	12	2
63	4.7	2.7	02, 06	8	2.2
63	4.7	2.9	03, 07	6	2.2
63	4.7	2.6	04, 08	6	2.7

DC Rated Voltage ( $U_R$ ) Max (V) (Note 1)	Capacitance Value C ( $\mu$ F) (Note 2)	AC Rated Current ( $I_{RA}$ ) Max (Arms)	Available Type Variants (See Para. 1.6) (Note 1)	Dimension B Max (mm) (See Para. 1.6)	Weight Max (g)
63	5.6	4.1	01, 05	12	2
63	5.6	3	02, 06	8	2.1
63	5.6	3.4	03, 07	6	2.2
63	5.6	3.1	04, 08	6	2.7
63	6.8	3.4	02, 06	10	2.6
63	6.8	3.8	03, 07	8	3
63	6.8	3.7	04, 08	6	2.7
63	8.2	3.6	02, 06	10	2.6
63	8.2	4.1	03, 07	8	3
63	8.2	4.1	04, 08	8	3.6
63	10	4.7	03, 07	10	3.7
63	10	4.4	04, 08	8	3.6
63	12	5	03, 07	10	3.7
63	12	5	04, 08	10	4.6
63	15	5.6	03, 07	12	4.7
63	15	5.4	04, 08	10	4.6
63	18	6.2	03, 07	14	5.2
63	18	6	04, 08	12	5.5
63	22	6.9	03, 07	17	6.3
63	22	6.6	04, 08	15	6.8
63	27	7.4	04, 08	17	7.8
100	0.56	1	01, 05	6	1
100	0.68	1.2	01, 05	6	1
100	0.82	1.5	01, 05	6	1
100	1	1.8	01, 05	6	1
100	1.2	2.1	01, 05	8	1.3
100	1.5	2.2	01, 05	8	1.3
100	1.5	1.2	02, 06	6	1.6
100	1.8	2.3	01, 05	8	1.3
100	1.8	1.4	02, 06	6	1.6
100	2.2	2.8	01, 05	10	1.7
100	2.2	1.7	02, 06	6	1.6
100	2.7	3.4	01, 05	10	1.7
100	2.7	1.8	02, 06	6	1.6
100	2.7	1.9	03, 07	6	2.2
100	3.3	3.8	01, 05	12	2
100	3.3	2.5	02, 06	8	2.1
100	3.3	2.3	03, 07	6	2.2
100	3.9	2.9	02, 06	8	2.1



DC Rated Voltage ( $U_R$ ) Max (V) (Note 1)	Capacitance Value C ( $\mu$ F) (Note 2)	AC Rated Current ( $I_{RA}$ ) Max (Arms)	Available Type Variants (See Para. 1.6) (Note 1)	Dimension B Max (mm) (See Para. 1.6)	Weight Max (g)
100	3.9	2.4	03, 07	6	2.2
100	3.9	2.5	04, 08	6	2.7
100	4.7	3.3	02, 06	10	2.6
100	4.7	3.4	03, 07	8	3
100	4.7	3	04, 08	6	2.7
100	5.6	3.4	02, 06	10	2.6
100	5.6	3.8	03, 07	8	3
100	5.6	3.6	04, 08	8	3.6
100	6.8	4.3	03, 07	10	3.7
100	6.8	4.1	04, 08	8	3.6
100	8.2	4.6	03, 07	10	3.7
100	8.2	4.4	04, 08	8	3.6
100	10	5.2	03, 07	12	4.7
100	10	5	04, 08	10	4.6
100	12	5.8	03, 07	14	5.2
100	12	5.5	04, 08	12	5.5
100	15	6.3	03, 07	17	6.3
100	15	5.7	04, 08	12	5.5
100	18	6.4	04, 08	15	6.8
100	22	7	04, 08	17	7.8
170	0.33	0.8	01, 05	6	1
170	0.39	1	01, 05	6	1
170	0.47	1.2	01, 05	6	1
170	0.56	1.4	01, 05	6	1
170	0.68	1.7	01, 05	8	1.3
170	0.82	2.1	01, 05	8	1.3
170	0.82	1.1	02, 06	6	1.6
170	1	2.5	01, 05	10	1.7
170	1	1.3	02, 06	6	1.6
170	1.2	2.8	01, 05	10	1.7
170	1.2	1.4	02, 06	6	1.6
170	1.5	3.3	01, 05	12	2
170	1.5	1.7	02, 06	6	1.6
170	1.5	1.6	03, 07	6	2.2
170	1.8	3.8	01, 05	12	2
170	1.8	2	02, 06	8	2.1
170	1.8	1.9	03, 07	6	2.2
170	2.2	2.5	02, 06	8	2.1
170	2.2	2.3	03, 07	6	2.2

DC Rated Voltage ( $U_R$ ) Max (V) (Note 1)	Capacitance Value C ( $\mu$ F) (Note 2)	AC Rated Current ( $I_{RA}$ ) Max (Arms)	Available Type Variants (See Para. 1.6) (Note 1)	Dimension B Max (mm) (See Para. 1.6)	Weight Max (g)
170	2.2	2	04, 08	6	2.7
170	2.7	3	02, 06	10	2.6
170	2.7	2.8	03, 07	8	3
170	2.7	2.5	04, 08	6	2.7
170	3.3	3.2	02, 06	10	2.6
170	3.3	3.3	03, 07	8	3
170	3.3	3	04, 08	8	3.6
170	3.9	3.7	03, 07	10	3.7
170	3.9	3.5	04, 08	8	3.6
170	4.7	4	03, 07	10	3.7
170	4.7	4	04, 08	10	4.6
170	5.6	4.5	03, 07	12	4.7
170	5.6	4.2	04, 08	10	4.6
170	6.8	5	03, 07	14	5.2
170	6.8	4.8	04, 08	12	5.5
170	8.2	5.7	03, 07	17	6.3
170	8.2	5.1	04, 08	12	5.5
170	10	5.8	04, 08	15	6.8
170	12	6.2	04, 08	15	7.8
200	0.22	0.7	01, 05	6	1
200	0.27	0.8	01, 05	6	1
200	0.33	1	01, 05	6	1
200	0.39	1.1	01, 05	6	1
200	0.47	1.5	01, 05	8	1.3
200	0.56	1.6	01, 05	8	1.3
200	0.56	0.8	02, 06	6	1.6
200	0.68	2.1	01, 05	10	1.7
200	0.68	1	02, 06	6	1.6
200	0.82	2.5	01, 05	10	1.7
200	0.82	1.2	02, 06	6	1.6
200	1	3.1	01, 05	12	2
200	1	1.3	02, 06	6	1.6
200	1	1.3	03, 07	6	2.2
200	1.2	3.2	01, 05	12	2
200	1.2	1.7	02, 06	8	2.1
200	1.2	1.6	03, 07	6	2.2
200	1.5	2	02, 06	8	2.1
200	1.5	1.8	03, 07	6	2.2
200	1.5	1.8	04, 08	6	2.7

DC Rated Voltage ( $U_R$ ) Max (V) (Note 1)	Capacitance Value C ( $\mu$ F) (Note 2)	AC Rated Current ( $I_{RA}$ ) Max (Arms)	Available Type Variants (See Para. 1.6) (Note 1)	Dimension B Max (mm) (See Para. 1.6)	Weight Max (g)
200	1.8	2.6	02, 06	10	2.6
200	1.8	2.4	03, 07	8	3
200	1.8	2	04, 08	6	2.7
200	2.2	3	02, 06	10	2.6
200	2.2	2.9	03, 07	8	3
200	2.2	2.6	04, 08	8	3.6
200	2.7	3	03, 07	8	3.7
200	2.7	3.2	04, 08	8	3.6
200	3.3	3.8	03, 07	10	3.7
200	3.3	3.9	04, 08	10	4.6
200	3.9	4.2	03, 07	12	4.7
200	3.9	4	04, 08	10	4.6
200	4.7	5	03, 07	14	5.2
200	4.7	4.7	04, 08	12	5.5
200	5.6	5.4	03, 07	17	6.3
200	5.6	5.4	04, 08	15	6.8
200	6.8	5.5	04, 08	15	6.8
200	8.2	6.2	04, 08	17	7.8
250	0.18	0.7	01, 05	6	1
250	0.22	0.9	01, 05	6	1
250	0.27	1.1	01, 05	6	1
250	0.33	1.3	01, 05	6	1
250	0.39	1.6	01, 05	8	1.3
250	0.47	1.9	01, 05	8	1.3
250	0.47	0.8	02, 06	6	1.6
250	0.56	2.2	01, 05	10	1.7
250	0.56	1	02, 06	6	1.6
250	0.68	2.6	01, 05	10	1.7
250	0.68	1.2	02, 06	6	1.6
250	0.82	2.9	01, 05	12	2
250	0.82	1.4	02, 06	6	1.6
250	0.82	1.3	03, 07	6	2.2
250	1	3.1	01, 05	12	2
250	1	1.7	02, 06	8	2.1
250	1	1.6	03, 07	6	2.2
250	1.2	2.1	02, 06	8	2.1
250	1.2	1.9	03, 07	6	2.2
250	1.2	1.7	04, 08	6	2.7
250	1.5	2.6	02, 06	10	2.6

DC Rated Voltage ( $U_R$ ) Max (V) (Note 1)	Capacitance Value C ( $\mu$ F) (Note 2)	AC Rated Current ( $I_{RA}$ ) Max (Arms)	Available Type Variants (See Para. 1.6) (Note 1)	Dimension B Max (mm) (See Para. 1.6)	Weight Max (g)
250	1.5	2.4	03, 07	8	3
250	1.5	2.1	04, 08	6	2.7
250	1.8	2.9	02, 06	10	2.6
250	1.8	2.9	03, 07	8	3
250	1.8	2.6	04, 08	8	3.6
250	2.2	3.2	03, 07	8	3
250	2.2	3.1	04, 08	8	3.6
250	2.7	3.7	03, 07	10	3.7
250	2.7	3.6	04, 08	10	4.6
250	3.3	4.2	03, 07	12	4.7
250	3.3	3.9	04, 08	10	4.6
250	3.9	4.6	03, 07	14	5.2
250	3.9	4.4	04, 08	12	5.5
250	4.7	5.3	03, 07	17	6.3
250	4.7	5	04, 08	15	6.8
250	5.6	5.3	04, 08	15	6.8
250	6.8	5.9	04, 08	17	7.8
400	0.068	0.4	01, 05	6	1
400	0.082	0.5	01, 05	6	1
400	0.1	0.6	01, 05	6	1
400	0.12	0.7	01, 05	6	1
400	0.15	0.8	01, 05	6	1
400	0.18	1	01, 05	8	1.3
400	0.18	0.5	02, 06	6	1.6
400	0.22	1.2	01, 05	8	1.3
400	0.22	0.6	02, 06	6	1.6
400	0.27	1.5	01, 05	10	1.7
400	0.27	0.7	02, 06	6	1.6
400	0.33	1.9	01, 05	12	2
400	0.33	0.9	02, 06	6	1.6
400	0.33	0.9	03, 07	6	2.2
400	0.39	2.2	01, 05	12	2
400	0.39	1	02, 06	8	2.1
400	0.39	1	03, 07	6	2.2
400	0.47	1.2	02, 06	8	2.1
400	0.47	1.1	03, 07	6	2.2
400	0.47	1	04, 08	6	2.7
400	0.56	1.5	02, 06	10	2.6
400	0.56	1.4	03, 07	8	3

DC Rated Voltage ( $U_R$ ) Max (V) (Note 1)	Capacitance Value C ( $\mu$ F) (Note 2)	AC Rated Current ( $I_{RA}$ ) Max (Arms)	Available Type Variants (See Para. 1.6) (Note 1)	Dimension B Max (mm) (See Para. 1.6)	Weight Max (g)
400	0.56	1.5	04, 08	10	2.7
400	0.68	1.8	02, 06	10	2.6
400	0.68	1.6	03, 07	8	3
400	0.68	1.6	04, 08	8	3.6
400	0.82	2	03, 07	8	3
400	0.82	1.8	04, 08	8	3.6
400	1	2.4	03, 07	10	3.7
400	1	2.1	04, 08	10	4.6
400	1.2	2.9	03, 07	10	3.7
400	1.2	2.6	04, 08	10	4.6
400	1.5	3.6	03, 07	14	5.2
400	1.5	3.2	04, 08	12	5.5
400	1.8	3.8	03, 07	14	5.2
400	1.8	3.6	04, 08	12	5.5
400	2.2	4.2	03, 07	17	6.3
400	2.2	4.2	04, 08	15	6.8
400	2.7	4.7	04, 08	17	7.8
500	0.033	0.3	01, 05	6	1
500	0.039	0.4	01, 05	6	1
500	0.047	0.5	01, 05	6	1
500	0.056	0.6	01, 05	6	1
500	0.068	0.7	01, 05	6	1
500	0.082	0.8	01, 05	8	1.3
500	0.1	1	01, 05	8	1.3
500	0.12	1.2	01, 05	10	1.7
500	0.12	0.4	02, 06	6	1.6
500	0.15	1.5	01, 05	10	1.7
500	0.15	0.5	02, 06	6	1.6
500	0.18	1.8	01, 05	12	2
500	0.18	0.6	02, 06	6	1.6
500	0.22	0.8	02, 06	6	1.6
500	0.22	0.8	03, 07	6	2.2
500	0.27	0.9	02, 06	8	2.1
500	0.27	1	03, 07	6	2.2
500	0.27	0.8	04, 08	6	2.7
500	0.33	1.1	02, 06	8	2.1
500	0.33	1.2	03, 07	8	3
500	0.33	1	04, 08	6	2.7
500	0.39	1.4	02, 06	10	2.6

DC Rated Voltage ( $U_R$ ) Max (V) (Note 1)	Capacitance Value C ( $\mu$ F) (Note 2)	AC Rated Current ( $I_{RA}$ ) Max (Arms)	Available Type Variants (See Para. 1.6) (Note 1)	Dimension B Max (mm) (See Para. 1.6)	Weight Max (g)
500	0.39	1.4	03, 07	8	3
500	0.39	1.2	04, 08	6	2.7
500	0.47	1.6	02, 06	10	2.6
500	0.47	1.7	03, 07	8	3
500	0.47	1.5	04, 08	8	3.6
500	0.56	2	03, 07	10	3.7
500	0.56	1.7	04, 08	8	3.6
500	0.68	2.4	03, 07	10	3.7
500	0.68	2.1	04, 08	8	3.6
500	0.82	2.9	03, 07	12	4.7
500	0.82	2.6	04, 08	10	4.6
500	1	3.4	03, 07	14	5.2
500	1	3.1	04, 08	12	5.5
500	1.2	3.9	03, 07	17	6.3
500	1.2	3.7	04, 08	15	6.8
500	1.5	4.1	04, 08	15	6.8
500	1.8	4.6	04, 08	17	7.8
630	0.022	0.3	01, 05	6	1
630	0.027	0.3	01, 05	6	1
630	0.033	0.4	01, 05	6	1
630	0.039	0.5	01, 05	6	1
630	0.047	0.6	01, 05	8	1.3
630	0.056	0.7	01, 05	8	1.3
630	0.068	0.8	01, 05	10	1.7
630	0.068	0.4	02, 06	6	1.6
630	0.082	1	01, 05	10	1.7
630	0.082	0.5	02, 06	6	1.6
630	0.1	1	01, 05	12	1.7
630	0.1	0.6	02, 06	6	1.6
630	0.12	1.5	01, 05	12	2
630	0.12	0.6	02, 06	6	1.6
630	0.12	0.5	03, 07	6	2.2
630	0.15	0.7	02, 06	8	2.1
630	0.15	0.7	03, 07	6	2.2
630	0.18	0.9	02, 06	8	2.1
630	0.18	0.8	03, 07	6	2.2
630	0.18	0.7	04, 08	6	2.7
630	0.22	1.1	02, 06	10	2.6
630	0.22	1	03, 07	8	3

DC Rated Voltage ( $U_R$ ) Max (V) (Note 1)	Capacitance Value C ( $\mu$ F) (Note 2)	AC Rated Current ( $I_{RA}$ ) Max (Arms)	Available Type Variants (See Para. 1.6) (Note 1)	Dimension B Max (mm) (See Para. 1.6)	Weight Max (g)
630	0.22	0.9	04, 08	6	2.7
630	0.27	1.3	02, 06	10	2.6
630	0.27	1.2	03, 07	8	3
630	0.27	1.1	04, 08	8	3.6
630	0.33	1.5	03, 07	8	3
630	0.33	1.3	04, 08	8	3.6
630	0.39	1.8	03, 07	10	3.7
630	0.39	1.5	04, 08	10	4.6
630	0.47	2.1	03, 07	12	4.7
630	0.47	1.8	04, 08	10	4.6
630	0.56	2.5	03, 07	12	4.7
630	0.56	2.2	04, 08	12	5.5
630	0.68	3.1	03, 07	17	6.3
630	0.68	2.7	04, 08	12	5.5
630	0.82	3.2	04, 08	15	6.8
630	1	3.7	04, 08	15	6.8
630	1.2	4.1	04, 08	17	7.8

**NOTES:**

- The allowable voltage variation for each combination of Type Variant and DC Rated Voltage is shown below.

**ALLOWABLE VOLTAGE VARIATION  $dV/dt$  (V/ $\mu$ s)**

Type Variants	DC Rated Voltage ( $U_R$ )								
	50V	63V	100V	170V	200V	250V	400V	500V	630V
01, 05	50	70	80	130	140	150	230	370	440
02, 06	30	40	40	60	60	70	100	130	170
03, 07	20	30	40	50	60	70	100	130	160
04, 08	15	30	30	50	50	60	90	120	140

- Two Capacitance Tolerances are available:
  - $\pm 20\%$  for E6 Series Capacitance Values
  - $\pm 10\%$  for E12 Series Capacitance Values

1.5 **MAXIMUM RATINGS**

The maximum ratings shall not be exceeded at any time during use or storage.

Maximum ratings shall only be exceeded during testing to the extent specified in this specification and when stipulated in Test Methods and Procedures of the ESCC Generic Specification.

Characteristics	Symbols	Maximum Ratings	Units	Remarks
DC Rated Voltage	$U_R$	50, 63, 100, 170, 200, 250, 400, 500, 630	V	Notes 1, 2
DC Category Voltage	$U_C$	Note 2	V	Over $T_{op}$
AC Current	$I_{RA}$	See Para. 1.4.2.2	Arms	f = 300kHz Note 3
Operating Temperature Range	$T_{op}$	-55 to +125	°C	$T_{amb}$
Storage Temperature Range	$T_{stg}$	-55 to +125	°C	
Soldering Temperature Variants 01 to 04 Variants 05 to 08	$T_{sol}$	+215 +260	°C	Note 4 Note 5

**NOTES:**

1. As required; See Para. 1.4.2.2.
2. The DC Rated Voltage is also the DC Category Voltage when  $T_{op}$  is between  $-55^{\circ}\text{C}$  ( $T_{amb}$ ) and  $+100^{\circ}\text{C}$  ( $T_{amb}$ ). For  $T_{op} > +100^{\circ}\text{C}$  ( $T_{amb}$ ) only the DC Category Voltage applies, and derating must be observed as follows:
  - $U_C$  derates linearly from 100% $U_C$  at  $T_{amb} = +100^{\circ}\text{C}$  to 80% $U_C$  at  $T_{amb} = +125^{\circ}\text{C}$ .
3. The AC Ripple Current  $I_{Ripple}$  (Arms) is 100% $I_{RA}$  when  $-55^{\circ}\text{C} < T_{amb} \leq +105^{\circ}\text{C}$ . For  $T_{amb} > +105^{\circ}\text{C}$  derating of  $I_{Ripple}$  must be observed as follows:
  - $I_{Ripple}$  derates linearly from 100% $I_{RA}$  at  $T_{amb} = +105^{\circ}\text{C}$  to 10% $I_{RA}$  at  $T_{amb} = +125^{\circ}\text{C}$ .
4. For reflow (vapour phase) soldering following a pre-heating phase at  $+130^{\circ}\text{C}$  maximum:
  - Temperature:  $+215^{\circ}\text{C}$
  - Duration: 20s minimum, 40s maximum.
5. Duration 5 seconds maximum at a distance of no less than 1mm from the body.



1.6 PHYSICAL DIMENSIONS AND TERMINAL IDENTIFICATION

1.6.1 Component Type Variants 01 to 04 (PM948S)

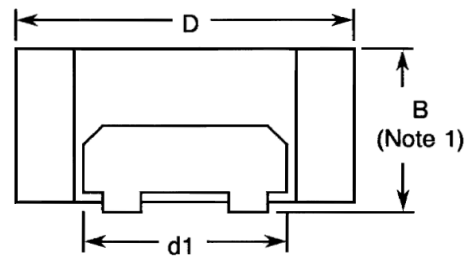
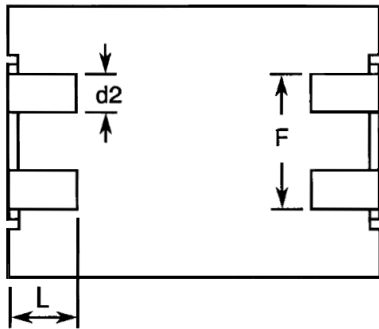

Type Variant	Dimensions (mm)									
	A Max	D Max	d1		d2		F		L	
			Min	Max	Min	Max	Min	Max	Min	Max
01	10.7	10.7	5.5	6.5	1.3	1.7	4.8	5.2	1.5	2.5
02	15.5	11.5	5.5	6.5	1.3	1.7	4.8	5.2	1.5	2.5
03	16.5	15.5	7.5	8.5	1.8	2.2	6.8	7.2	1.5	2.5
04	18.5	17	7.5	8.5	1.8	2.2	6.8	7.2	1.5	2.5

**NOTES:**

1. The limits of Dimension B are defined in Para. 1.4.2.2.
2. Terminal identification: A voltage polarity “+” symbol shall be marked on the top of the body to indicate the terminal which should be connected to the highest potential.

1.6.2 Component Type Variants 05 to 08 (PM948NS)  
 (For illustrative purposes Type Variant 08 with 2 rows of 6 terminals is shown)

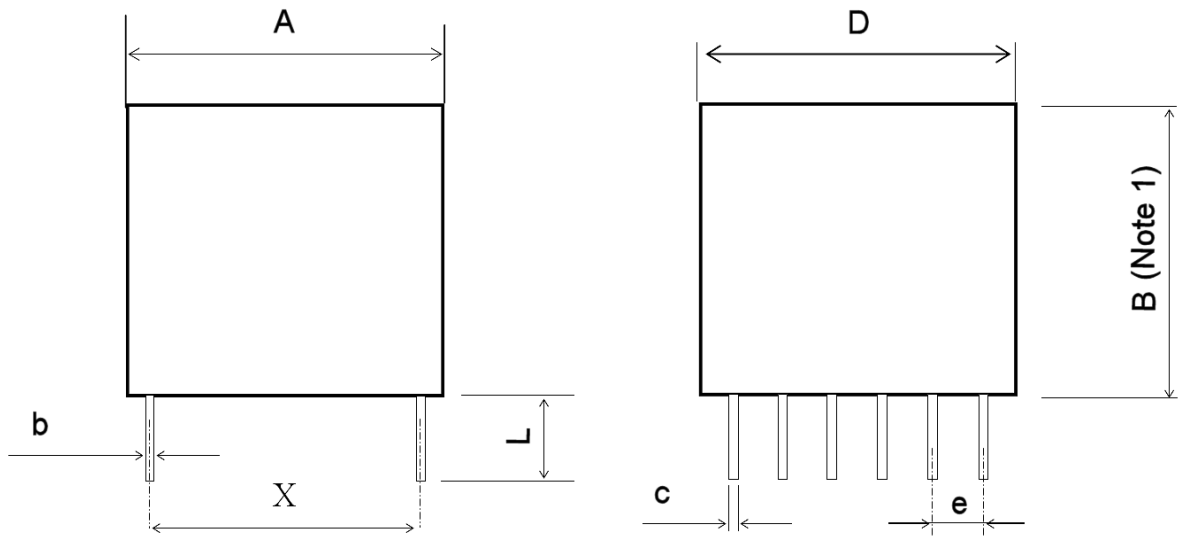

Type Variant	Dimensions (mm)										No. of terminals per row	
	A Max	D Max	X		b		c		e			L Min
			Min	Max	Min	Max	Min	Max	Min	Max		
05	10.7	10.7	8.2	8.3	0.15	0.35	0.4	0.6	2.34	2.74	5	4
06	15.5	11.5	13.95	14.05	0.15	0.35	0.4	0.6	2.34	2.74	5	4
07	16.5	15.5	13.95	14.05	0.15	0.35	0.4	0.6	2.34	2.74	5	5
08	18.5	17	15.19	15.29	0.15	0.35	0.4	0.6	2.34	2.74	5	6

**NOTES:**

1. The limits of Dimension B are defined in Para. 1.4.2.2.
2. Terminal identification: A voltage polarity “+” symbol shall be marked on the top of the body to indicate the row of terminals which should be connected to the highest potential.

1.7 FUNCTIONAL DIAGRAM

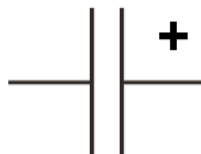

**NOTES:**

1. These capacitors are not polarised; however, marking includes the voltage polarity symbol (see Para. 1.6) which should be respected in use.
2. For Component Type Variants 05 to 08, each row of terminals is connected internally to a single electrode.

## 1.8 MATERIALS AND FINISHES

### 1.8.1 Lead/Terminal Material

The Lead/Terminal Material shall be brass with silver plating.

### 1.8.2 Lead/Terminal Finish

The Lead/Terminal Finish shall be either Type 3 or Type 4 in accordance with the requirements of ESCC Basic Specification No. [23500](#).

## 2 REQUIREMENTS

### 2.1 GENERAL

The complete requirements for procurement of the components specified herein are as stated in this specification and the ESCC Generic Specification. Permitted deviations from the Generic Specification, applicable to this specification only, are listed below.

Permitted deviations from the Generic Specification and this Detail Specification, formally agreed with specific Manufacturers on the basis that the alternative requirements are equivalent to the ESCC requirement and do not affect the component's reliability, are listed in the appendices attached to this specification.

#### 2.1.1 Deviations from the Generic Specification

##### 2.1.1.1 *Deviations from Qualification and Periodic Tests – Chart F4*

- (a) Vibration and Shock, Test Condition (d) or (e) as applicable, Mounting: Components shall be soldered to a suitable substrate which shall in turn be connected to either the vibration generator or shock machine (as required). Prior to soldering, to avoid any thermal stress, the terminations of the components shall be pre-tinned and then cured.
- (b) Operating Life:
  - Test Condition (c), Applied voltage:  $1.25 \times U_c$ , where  $U_c$  is the applicable Category Voltage per Paras. 1.5 and 1.4.2.2.
- (c) Robustness of Terminations: For Component Type Variants 01 to 04 Robustness of Terminations shall be performed as follows:

The components shall be mounted on a suitable substrate. After mounting, examination shall be made for good tinning as evidenced by flowing of the solder with wetting of the terminations. A force of 10N shall be applied normal to the line joining the terminals and in a plane parallel to the substrate, for a duration of  $10 \pm 1s$ . The components shall then be examined and there shall be no evidence of damage or loosening of the components from the substrate.
- (d) Solderability: For Component Type Variants 01 to 04 Solderability shall be performed in accordance with IEC Publication No. 60068-2-58. The following details shall apply:
  - Test Conditions:
    - Temperature:  $+215 \pm 3^\circ C$
    - Immersion time:  $3 \pm 0.3s$
    - Immersion distance: 1mm minimum, 2mm maximum.
- (e) Resistance to Soldering Heat: For Component Type Variants 01 to 04 Resistance to Soldering Heat shall be performed in accordance with IEC Publication No. 60068-2-58. The following details shall apply:
  - Test Conditions:
    - Temperature:  $+215 \pm 3^\circ C$
    - Immersion time: 40s
    - Immersion distance: 1mm minimum, 2mm maximum.
  - Data Points: As defined in Resistance to Soldering Heat in the Generic Specification.

2.2 MARKING

The marking shall be in accordance with the requirements of ESCC Basic Specification No. 21700 and as follows.

The information to be marked on the component or its primary package shall be:

- (a) Terminal Identification (see Para. 1.6).
- (b) The ESCC qualified components symbol (for ESCC qualified components only).
- (c) The ESCC Component Number (see Para. 1.4.1).
- (d) Traceability information.

2.3 ROBUSTNESS OF TERMINATIONS

The terminals of the components are rigid.

For Component Type Variants 05 to 08 the test conditions for Robustness of Terminations shall be as specified in the ESCC Generic Specification and as follows:

- Test Ua1, tensile:
  - Applied force: 10N
  - Duration: 7.5 ±2.5s

All terminals of the component shall be tested.

2.4 ELECTRICAL MEASUREMENTS AT ROOM, HIGH AND LOW TEMPERATURES

Electrical measurements shall be performed at room, high and low temperatures.

2.4.1 Room Temperature Electrical Measurements

The measurements shall be performed at T<sub>amb</sub> = +22 ±3°C.

Characteristics	Symbols	Test Method and Conditions	Limits		Units
			Min	Max	
Capacitance	C	ESCC No. 3006 Test Frequency = 1kHz	Note 1	Note 2	µF
Tangent of Loss Angle	tgδ	ESCC No. 3006 Test Frequency = 1kHz	-	10×10 <sup>-3</sup>	-
Insulation Resistance, Dielectric	R <sub>I</sub>	ESCC No. 3006  C ≤ 0.33µF C > 0.33µF; U <sub>R</sub> > 100V C > 0.33µF; U <sub>R</sub> ≤ 100V (Notes 3, 4)	7500	-	MΩ
			2500	-	MΩ.µF
			1250	-	MΩ.µF
Voltage Proof, Terminal-to-Terminal	VP	ESCC No. 3006	1.6×U <sub>R</sub> (Note 4)	-	V

**NOTES:**

1. Capacitance Value of the component minus the applicable Tolerance (see Para. 1.4.2.2).
2. Capacitance Value of the component plus the applicable Tolerance (see Para. 1.4.2.2).
3. Measuring voltage applied during Insulation Resistance shall be as follows:
  - For U<sub>R</sub> ≤ 100V: V = U<sub>R</sub>.
  - For 100V < U<sub>R</sub> < 500V: V = 100V.
  - For U<sub>R</sub> ≥ 500V: V = 500V.
4. For the applicable Rated Voltage (U<sub>R</sub>) see Para. 1.4.2.2.

2.4.2 High and Low Temperatures Electrical Measurements

Characteristics	Symbols	Test Method and Conditions (Notes 1 and 2)	Limits		Units
			Min	Max	
Temperature Coefficient	$\Delta C/C$	ESCC No. 3006 Test Frequency = 1kHz $T_{amb} = -55 (+3 -0)^{\circ}C$	-	-10 (Note 3)	%
		$T_{amb} = +125 (+0 -3)^{\circ}C$	-	+18 (Note 3)	%

**NOTES:**

- For Component Type Variants 01 to 04, the measurements shall be performed on a sample of 6 components from each manufacturing lot, mounted onto a suitable substrate, with 0 failures allowed. Any failures shall result in lot failure. This test is considered to be destructive and therefore components so tested shall not form part of the delivery lot.
- For Component Type Variants 05 to 08, the measurements shall be performed on a sample of 6 components from each manufacturing lot with 0 failures allowed. In the event of any failure a 100% inspection may be performed.
- The Temperature Coefficient limits are with respect to the capacitance at  $+22 \pm 2^{\circ}C$  (reference point temperature).

2.5 INTERMEDIATE AND END-POINT ELECTRICAL MEASUREMENTS

Unless otherwise specified, the measurements shall be performed at  $T_{amb} = +22 \pm 3^{\circ}C$ .

Unless otherwise specified the test methods and test conditions shall be as per the corresponding test defined in Para. 2.4.1, Room Temperature Electrical Measurements.

Test Reference per ESCC No. 3006	Characteristics	Symbols	Limits		Units
			Min	Max	
Resistance to Soldering Heat Initial Measurements Final Measurements	Capacitance	C	Note 1		$\mu F$
	Capacitance	C	Note 1		$\mu F$
	Change in Capacitance	$\Delta C/C$	-3	+3	%
	Insulation Resistance, Dielectric	$R_i$			
	$C \leq 0.33\mu F$		Note 1	-	G $\Omega$
	$C > 0.33\mu F; U_R > 100V$		Note 1	-	M $\Omega.\mu F$
	$C > 0.33\mu F; U_R \leq 100V$		Note 1	-	M $\Omega.\mu F$
	Tangent of Loss Angle	$tg\delta$	-	Note 2	-
Temperature Coefficient	Temperature Coefficient (Note 3)	$\Delta C/C$	Note 4		%
Rapid Change of Temperature Initial Measurements	Capacitance	C	Note 1		$\mu F$

Test Reference per ESCC No. 3006	Characteristics	Symbols	Limits		Units
			Min	Max	
Rapid Change of Temperature (continued) Final Measurements	Capacitance Change in Capacitance Tangent of Loss Angle	C $\Delta C/C$ $tg\delta$	Note 1 -3   +3 -   Note 1		$\mu F$ % -
Climatic Sequence Initial Measurements Final Measurements	Capacitance Capacitance Change in Capacitance Tangent of Loss Angle Voltage Proof, Terminal-to-Terminal Insulation Resistance, Dielectric  $C \leq 0.33\mu F$ $C > 0.33\mu F; U_R > 100V$ $C > 0.33\mu F; U_R \leq 100V$	C C $\Delta C/C$ $tg\delta$ VP  $R_i$	Note 1 Note 1 -3   +3 -   Note 2 Note 1   -  Note 5   - Note 5   - Note 5   -		$\mu F$ $\mu F$ % - V  G $\Omega$ M $\Omega$ . $\mu F$ M $\Omega$ . $\mu F$
Operating Life Initial Measurements Intermediate Measurements (1000 hours)	Capacitance Capacitance Change in Capacitance	C C $\Delta C/C$	Note 1 Note 1 -5   +5		$\mu F$ $\mu F$ %
Final Measurements (1000 or 2000 hours) (Note 6)	Capacitance Change in Capacitance Tangent of Loss Angle Insulation Resistance, Dielectric  $C \leq 0.33\mu F$ $C > 0.33\mu F; U_R > 100V$ $C > 0.33\mu F; U_R \leq 100V$	C $\Delta C/C$ $tg\delta$ $R_i$	Note 1 -5   +5 -   Note 2  Note 5   - Note 5   - Note 5   -		$\mu F$ % -  G $\Omega$ M $\Omega$ . $\mu F$ M $\Omega$ . $\mu F$

**NOTES:**

- As specified in Para. 2.4.1.
- 1.5× the limit specified in Para. 2.4.1.
- The test method and test conditions shall be as specified in Para. 2.4.2.
- As specified in Para. 2.4.2.
- 50% of the limit specified in Para. 2.4.1.
- 1000 hours is applicable to Periodic Testing for extension of qualification. 2000 hours is applicable to Qualification Testing, and to Periodic Testing for renewal of qualification after lapse.

## 2.6

**BURN-IN CONDITIONS**

Characteristics	Symbols	Conditions (Note 1)	Units
Ambient Temperature	$T_{amb}$	+125 (+0 -5)	°C
Test Voltage	$V_T$	1.25× $U_C$ (Note 2)	V

**NOTES:**

1. On completion of Burn-in the components shall be removed from the burn-in chamber and allowed to cool, under normal atmospheric conditions, for recovery for 24 ±2 hours.
2.  $U_C$  is the applicable Category Voltage; see Paras. 1.5 and 1.4.2.2.

**APPENDIX 'A'****AGREED DEVIATIONS FOR EXXELIA TECHNOLOGIES (F)**

Items Affected	Description of Deviations
Para. 2.1.1, Deviations from the Generic Specification: Deviations from Screening Tests – Chart F3	If a particular lot is required to undergo testing in accordance with Chart F4 then the results of the Temperature Coefficient measurements, made during High and Low Temperatures Electrical Measurements on a sample of 6 randomly-selected capacitors, shall be recorded.  These measurements may also be performed at the end of Chart F3 in order that the sample of components can include any components which passed post-Burn-in Room Temperature Electrical Measurements but subsequently failed External Visual Inspection.
Para. 2.1.1.1, Deviations from Qualification and Periodic Tests – Chart F4	The Temperature Coefficient measurements recorded during Screening Tests may be used in lieu of the performance of the Temperature Coefficient test as specified in Subgroup 2B of Chart F4.