



**CAPACITORS, FIXED, SURFACE MOUNT,
DC SELF-HEALING, NON-INDUCTIVE,
POLYPHENYLENE SULPHIDE DIELECTRIC**

BASED ON TYPE KM94S

ESCC Detail Specification No. 3006/023

Issue 8	September 2023
---------	----------------



LEGAL DISCLAIMER AND COPYRIGHT

European Space Agency, Copyright © 2023. All rights reserved.

The European Space Agency disclaims any liability or responsibility, to any person or entity, with respect to any loss or damage caused, or alleged to be caused, directly or indirectly by the use and application of this ESCC publication.

This publication, without the prior permission of the European Space Agency and provided that it is not used for a commercial purpose, may be:

- copied in whole, in any medium, without alteration or modification.
- copied in part, in any medium, provided that the ESCC document identification, comprising the ESCC symbol, document number and document issue, is removed.

DOCUMENTATION CHANGE NOTICE

(Refer to <https://escies.org> for ESCC DCR content)

DCR No.	CHANGE DESCRIPTION
1584	Specification updated to incorporate changes per DCR.

TABLE OF CONTENTS

1	GENERAL	5
1.1	SCOPE	5
1.2	APPLICABLE DOCUMENTS	5
1.3	TERMS, DEFINITIONS, ABBREVIATIONS, SYMBOLS AND UNITS	5
1.4	THE ESCC COMPONENT NUMBER AND COMPONENT TYPE VARIANTS	5
1.4.1	The ESCC Component Number	5
1.4.1.1	Characteristics and Ratings Codes	6
1.4.2	Component Type Variants and Range of Components	7
1.4.2.1	Component Type Variants	7
1.4.2.2	Range of Components	7
1.5	MAXIMUM RATINGS	22
1.6	PHYSICAL DIMENSIONS	22
1.7	FUNCTIONAL DIAGRAM	23
2	REQUIREMENTS	23
2.1	GENERAL	23
2.1.1	Deviations from the Generic Specification	23
2.1.1.1	Deviations from Qualification and Periodic Tests – Chart F4	23
2.2	MARKING	24
2.3	ROBUSTNESS OF TERMINATIONS	24
2.4	ELECTRICAL MEASUREMENTS AT ROOM, HIGH AND LOW TEMPERATURES	24
2.4.1	Room Temperature Electrical Measurements	24
2.4.2	High and Low Temperatures Electrical Measurements	25
2.5	INTERMEDIATE AND END-POINT ELECTRICAL MEASUREMENTS	25
2.6	BURN-IN CONDITIONS	27
	APPENDIX 'A'	28

1 GENERAL

1.1 SCOPE

This specification details the ratings, physical and electrical characteristics, and test and inspection data for the component type variants and/or the Component Type Variants and Range of Components specified below. It supplements the requirements of, and shall be read in conjunction with, the ESCC Generic Specification listed under Applicable Documents.

1.2 APPLICABLE DOCUMENTS

The following documents form part of this specification and shall be read in conjunction with it:

- (a) ESCC Generic Specification No. [3006](#).

1.3 TERMS, DEFINITIONS, ABBREVIATIONS, SYMBOLS AND UNITS

For the purpose of this specification, the terms, definitions, abbreviations, symbols and units specified in ESCC Basic Specification No. [21300](#) shall apply.

1.4 THE ESCC COMPONENT NUMBER AND COMPONENT TYPE VARIANTS

1.4.1 The ESCC Component Number

The ESCC Component Number shall be constituted as follows:

Example: 3006023032433KE

- Detail Specification Reference: 3006023
- Component Type Variant Number: 03 (as required)
- Characteristic code: Capacitance Value (243nF): 2433 (as required)
- Characteristic code: Capacitance Tolerance ($\pm 10\%$): K (as required)
- Rating code: Rated Voltage (100V): E (as required)

1.4.1.1 Characteristics and Ratings Codes

Characteristics and ratings to be codified as part of the ESCC Component Number shall be as follows:

- (a) Capacitance Value, C, expressed by means of the following codes in accordance with ESCC Basic Specification No. 21700. The unit quantity shall be picofarads (pF).

Capacitance Value C (pF)	Code
XXX 10 ¹	XXX1
XXX 10 ²	XXX2
XXX 10 ³	XXX3
XXX 10 ⁴	XXX4

- (b) Capacitance Tolerance expressed by the following codes in accordance with ESCC Basic Specification No. 21700:

Tolerance (±)	Code Letter
1%	F
2%	G
5%	J
10%	K

- (c) DC Rated Voltage, U_R, expressed by the following codes:

DC Rated Voltage U _R (V)	Code Letter
50	C
100	E

1.4.2 Component Type Variants and Range of Components

1.4.2.1 *Component Type Variants*

Three Component Type Variants are defined in this specification with each Type Variant being a different size of surface mount package. See Para. 1.6 for details.

The surface mount package shall have a terminal finish of either '3' or '4' in accordance with the requirements of ESCC Basic Specification No. [23500](#).

1.4.2.2 *Range of Components*

The range of components applicable to this specification are as follows:

DC Rated Voltage (U_R) Max (V)	Capacitance Value (C) (nF) (Note 1)	AC Rated Current (I_{RA}) Max (Arms)	Available Type Variant (See Para. 1.6)	Weight Max (g)
50	4.64	0.07	01	0.6
50	4.7	0.07	01	0.6
50	4.75	0.07	01	0.6
50	4.87	0.07	01	0.6
50	4.99	0.07	01	0.6
50	5.1	0.07	01	0.6
50	5.11	0.07	01	0.6
50	5.23	0.07	01	0.6
50	5.36	0.07	01	0.6
50	5.49	0.07	01	0.6
50	5.6	0.07	01	0.6
50	5.62	0.07	01	0.6
50	5.76	0.07	01	0.6
50	5.9	0.07	01	0.6
50	6.04	0.07	01	0.6
50	6.19	0.07	01	0.6
50	6.2	0.07	01	0.6
50	6.34	0.07	01	0.6
50	6.49	0.07	01	0.6
50	6.65	0.07	01	0.6
50	6.8	0.1	01	0.6
50	6.81	0.1	01	0.6
50	6.98	0.1	01	0.6
50	7.15	0.1	01	0.6
50	7.32	0.1	01	0.6
50	7.5	0.1	01	0.6
50	7.68	0.1	01	0.6
50	7.87	0.1	01	0.6
50	8.06	0.1	01	0.6
50	8.2	0.1	01	0.6
50	8.25	0.1	01	0.6

DC Rated Voltage (U_R) Max (V)	Capacitance Value (C) (nF) (Note 1)	AC Rated Current (I_{RA}) Max (Arms)	Available Type Variant (See Para. 1.6)	Weight Max (g)
50	8.45	0.1	01	0.6
50	8.66	0.1	01	0.6
50	8.87	0.1	01	0.6
50	9.09	0.1	01	0.6
50	9.1	0.1	01	0.6
50	9.31	0.1	01	0.6
50	9.53	0.1	01	0.6
50	9.76	0.1	01	0.6
50	10	0.1	01	0.6
50	10.2	0.1	01	0.6
50	10.5	0.1	01	0.6
50	10.7	0.1	01	0.6
50	11	0.1	01	0.6
50	11.3	0.1	01	0.6
50	11.5	0.1	01	0.6
50	11.8	0.1	01	0.6
50	12	0.1	01	0.6
50	12.1	0.1	01	0.6
50	12.4	0.1	01	0.6
50	12.7	0.1	01	0.6
50	13	0.1	01	0.6
50	13.3	0.1	01	0.6
50	13.7	0.1	01	0.6
50	14	0.1	01	0.6
50	14.3	0.1	01	0.6
50	14.7	0.1	01	0.6
50	15	0.15	01	0.6
50	15.4	0.15	01	0.6
50	15.8	0.15	01	0.6
50	16	0.15	01	0.6
50	16.2	0.15	01	0.6
50	16.5	0.15	01	0.6
50	16.9	0.15	01	0.6
50	17.4	0.15	01	0.6
50	17.8	0.15	01	0.6
50	18	0.15	01	0.6
50	18.2	0.15	01	0.6
50	18.7	0.15	01	0.6
50	19.1	0.15	01	0.6
50	19.6	0.15	01	0.6

DC Rated Voltage (U_R) Max (V)	Capacitance Value (C) (nF) (Note 1)	AC Rated Current (I_{RA}) Max (Arms)	Available Type Variant (See Para. 1.6)	Weight Max (g)
50	20	0.15	01	0.6
50	20.5	0.15	01	0.6
50	21	0.15	01	0.6
50	21.5	0.15	01	0.6
50	22	0.16	01	0.6
50	22.1	0.16	01	0.6
50	22.6	0.16	01	0.6
50	23.2	0.16	01	0.6
50	23.7	0.16	01	0.6
50	24	0.16	01	0.6
50	24.3	0.16	01	0.6
50	24.9	0.16	01	0.6
50	25.5	0.16	01	0.6
50	26.1	0.16	01	0.6
50	26.7	0.16	01	0.6
50	27	0.16	01	0.6
50	27.4	0.16	01	0.6
50	28	0.16	01	0.6
50	28.7	0.16	01	0.6
50	29.4	0.16	01	0.6
50	30	0.16	01	0.6
50	30.1	0.16	01	0.6
50	30.9	0.16	01	0.6
50	31.6	0.16	01	0.6
50	32.4	0.16	01	0.6
50	33	0.21	01	0.6
50	33.2	0.21	01	0.6
50	34	0.21	01	0.6
50	34.8	0.21	01	0.6
50	35.7	0.21	01	0.6
50	36	0.21	01	0.6
50	36.5	0.21	01	0.6
50	37.4	0.21	01	0.6
50	38.3	0.21	01	0.6
50	39.2	0.21	01	0.6
50	40.2	0.21	01	0.6
50	41.2	0.21	01	0.6
50	42.2	0.21	01	0.6
50	43	0.21	01	0.6
50	43.2	0.21	01	0.6

DC Rated Voltage (U_R) Max (V)	Capacitance Value (C) (nF) (Note 1)	AC Rated Current (I_{RA}) Max (Arms)	Available Type Variant (See Para. 1.6)	Weight Max (g)
50	44.2	0.21	01	0.6
50	45.3	0.21	01	0.6
50	46.4	0.21	01	0.6
50	47	0.21	01	0.6
50	47.5	0.21	01	0.6
50	48.7	0.21	01	0.6
50	49.9	0.21	01	0.6
50	51	0.21	01	0.6
50	51.1	0.21	01	0.6
50	52.3	0.21	01	0.6
50	53.6	0.21	01	0.6
50	54.9	0.21	01	0.6
50	56	0.21	01	0.6
50	56.2	0.21	01	0.6
50	57.6	0.21	01	0.6
50	59	0.21	01	0.6
50	60.4	0.21	01	0.6
50	61.9	0.21	01	0.6
50	62	0.21	01	0.6
50	63.4	0.21	01	0.6
50	64.9	0.21	01	0.6
50	66.5	0.21	01	0.6
50	68	0.3	01	0.6
50	68.1	0.3	01	0.6
50	69.8	0.3	01	0.6
50	71.5	0.3	01	0.6
50	73.2	0.3	01	0.6
50	75	0.3	01	0.6
50	76.8	0.3	01	0.6
50	78.7	0.3	01	0.6
50	80.6	0.3	01	0.6
50	82	0.3	01	0.6
50	82.5	0.3	01	0.6
50	84.5	0.3	01	0.6
50	86.6	0.3	01	0.6
50	88.7	0.3	01	0.6
50	90.9	0.3	01	0.6
50	91	0.3	01	0.6
50	93.1	0.3	01	0.6
50	95.3	0.3	01	0.6

DC Rated Voltage (U_R) Max (V)	Capacitance Value (C) (nF) (Note 1)	AC Rated Current (I_{RA}) Max (Arms)	Available Type Variant (See Para. 1.6)	Weight Max (g)
50	97.6	0.3	01	0.6
50	100	0.4	01	0.6
50	102	0.4	01	0.6
50	105	0.4	01	0.6
50	107	0.4	01	0.6
50	110	0.4	01	0.6
50	113	0.4	01	0.6
50	115	0.4	01	0.6
50	118	0.4	01	0.6
50	120	0.4	01	0.6
50	121	0.4	01	0.6
50	124	0.4	01	0.6
50	127	0.4	01	0.6
50	130	0.4	01	0.6
50	133	0.4	01	0.6
50	137	0.4	01	0.6
50	140	0.4	01	0.6
50	143	0.4	01	0.6
50	147	0.4	01	0.6
50	150	0.41	01	0.6
50	154	0.41	01	0.6
50	158	0.41	01	0.6
50	160	0.41	01	0.6
50	162	0.41	01	0.6
50	165	0.41	01	0.6
50	169	0.41	01	0.6
50	174	0.41	01	0.6
50	178	0.41	01	0.6
50	180	0.41	01	0.6
50	182	0.41	01	0.6
50	187	0.41	01	0.6
50	191	0.41	01	0.6
50	196	0.41	01	0.6
50	200	0.41	01	0.6
50	205	0.41	01	0.6
50	210	0.41	01	0.6
50	215	0.41	01	0.6
50	220	0.6	01	0.6
50	221	0.6	01	0.6
50	226	0.6	02	0.9

DC Rated Voltage (U_R) Max (V)	Capacitance Value (C) (nF) (Note 1)	AC Rated Current (I_{RA}) Max (Arms)	Available Type Variant (See Para. 1.6)	Weight Max (g)
50	232	0.6	02	0.9
50	237	0.6	02	0.9
50	240	0.6	02	0.9
50	243	0.6	02	0.9
50	249	0.6	02	0.9
50	255	0.6	02	0.9
50	261	0.6	02	0.9
50	267	0.6	02	0.9
50	270	0.6	02	0.9
50	274	0.6	02	0.9
50	280	0.6	02	0.9
50	287	0.6	02	0.9
50	294	0.6	02	0.9
50	300	0.6	02	0.9
50	301	0.6	02	0.9
50	309	0.6	02	0.9
50	316	0.6	02	0.9
50	324	0.6	02	0.9
50	330	0.6	02	0.9
50	332	0.9	02	0.9
50	340	0.9	02	0.9
50	348	0.9	02	0.9
50	357	0.9	02	0.9
50	360	0.9	02	0.9
50	365	0.9	02	0.9
50	374	0.9	02	0.9
50	383	0.9	02	0.9
50	390	0.9	02	0.9
50	392	0.9	02	0.9
50	402	0.9	02	0.9
50	412	0.9	02	0.9
50	422	0.9	02	0.9
50	430	0.9	02	0.9
50	432	0.9	02	0.9
50	442	0.9	02	0.9
50	453	0.9	02	0.9
50	464	0.9	02	0.9
50	470	1.28	02	0.9
50	475	1.28	03	1.3
50	487	1.28	03	1.3

DC Rated Voltage (U_R) Max (V)	Capacitance Value (C) (nF) (Note 1)	AC Rated Current (I_{RA}) Max (Arms)	Available Type Variant (See Para. 1.6)	Weight Max (g)
50	499	1.28	03	1.3
50	510	1.28	03	1.3
50	511	1.28	03	1.3
50	523	1.28	03	1.3
50	536	1.28	03	1.3
50	549	1.28	03	1.3
50	560	1.28	03	1.3
50	562	1.28	03	1.3
50	576	1.28	03	1.3
50	590	1.28	03	1.3
50	604	1.28	03	1.3
50	619	1.28	03	1.3
50	620	1.28	03	1.3
50	634	1.28	03	1.3
50	649	1.28	03	1.3
50	665	1.28	03	1.3
50	680	1.28	03	1.3
50	681	1.45	03	1.3
50	698	1.45	03	1.3
50	715	1.45	03	1.3
50	732	1.45	03	1.3
50	750	1.45	03	1.3
50	768	1.45	03	1.3
50	787	1.45	03	1.3
50	806	1.45	03	1.3
50	820	1.45	03	1.3
50	825	1.45	03	1.3
50	845	1.45	03	1.3
50	866	1.45	03	1.3
50	887	1.45	03	1.3
50	909	1.45	03	1.3
50	910	1.45	03	1.3
50	931	1.45	03	1.3
50	953	1.45	03	1.3
50	976	1.45	03	1.3
50	1000	1.75	03	1.3

DC Rated Voltage (U_R) Max (V)	Capacitance Value (C) (nF) (Note 1)	AC Rated Current (I_{RA}) Max (Arms)	Available Type Variant (See Para. 1.6)	Weight Max (g)
100	1	0.03	01	0.6
100	1.02	0.03	01	0.6
100	1.05	0.03	01	0.6
100	1.07	0.03	01	0.6
100	1.1	0.03	01	0.6
100	1.13	0.03	01	0.6
100	1.15	0.03	01	0.6
100	1.18	0.03	01	0.6
100	1.2	0.03	01	0.6
100	1.21	0.03	01	0.6
100	1.24	0.03	01	0.6
100	1.27	0.03	01	0.6
100	1.3	0.03	01	0.6
100	1.33	0.03	01	0.6
100	1.37	0.03	01	0.6
100	1.4	0.03	01	0.6
100	1.43	0.03	01	0.6
100	1.47	0.03	01	0.6
100	1.5	0.05	01	0.6
100	1.54	0.05	01	0.6
100	1.58	0.05	01	0.6
100	1.6	0.05	01	0.6
100	1.62	0.05	01	0.6
100	1.65	0.05	01	0.6
100	1.69	0.05	01	0.6
100	1.74	0.05	01	0.6
100	1.78	0.05	01	0.6
100	1.8	0.05	01	0.6
100	1.82	0.05	01	0.6
100	1.87	0.05	01	0.6
100	1.91	0.05	01	0.6
100	1.96	0.05	01	0.6
100	2	0.05	01	0.6
100	2.05	0.05	01	0.6
100	2.1	0.05	01	0.6
100	2.15	0.05	01	0.6
100	2.2	0.07	01	0.6
100	2.21	0.07	01	0.6
100	2.26	0.07	01	0.6
100	2.32	0.07	01	0.6

DC Rated Voltage (U_R) Max (V)	Capacitance Value (C) (nF) (Note 1)	AC Rated Current (I_{RA}) Max (Arms)	Available Type Variant (See Para. 1.6)	Weight Max (g)
100	2.37	0.07	01	0.6
100	2.4	0.07	01	0.6
100	2.43	0.07	01	0.6
100	2.49	0.07	01	0.6
100	2.55	0.07	01	0.6
100	2.61	0.07	01	0.6
100	2.67	0.07	01	0.6
100	2.7	0.07	01	0.6
100	2.74	0.07	01	0.6
100	2.8	0.07	01	0.6
100	2.87	0.07	01	0.6
100	2.94	0.07	01	0.6
100	3	0.07	01	0.6
100	3.01	0.07	01	0.6
100	3.09	0.07	01	0.6
100	3.16	0.07	01	0.6
100	3.24	0.07	01	0.6
100	3.3	0.11	01	0.6
100	3.32	0.11	01	0.6
100	3.4	0.11	01	0.6
100	3.48	0.11	01	0.6
100	3.57	0.11	01	0.6
100	3.6	0.11	01	0.6
100	3.65	0.11	01	0.6
100	3.74	0.11	01	0.6
100	3.83	0.11	01	0.6
100	3.9	0.11	01	0.6
100	3.92	0.11	01	0.6
100	4.02	0.11	01	0.6
100	4.12	0.11	01	0.6
100	4.22	0.11	01	0.6
100	4.3	0.11	01	0.6
100	4.32	0.11	01	0.6
100	4.42	0.11	01	0.6
100	4.53	0.11	01	0.6
100	4.64	0.11	01	0.6
100	4.7	0.09	01	0.6
100	4.75	0.09	01	0.6
100	4.87	0.09	01	0.6
100	4.99	0.09	01	0.6

DC Rated Voltage (U_R) Max (V)	Capacitance Value (C) (nF) (Note 1)	AC Rated Current (I_{RA}) Max (Arms)	Available Type Variant (See Para. 1.6)	Weight Max (g)
100	5.1	0.09	01	0.6
100	5.11	0.09	01	0.6
100	5.23	0.09	01	0.6
100	5.36	0.09	01	0.6
100	5.49	0.09	01	0.6
100	5.6	0.09	01	0.6
100	5.62	0.09	01	0.6
100	5.76	0.09	01	0.6
100	5.9	0.09	01	0.6
100	6.04	0.09	01	0.6
100	6.19	0.09	01	0.6
100	6.2	0.09	01	0.6
100	6.34	0.09	01	0.6
100	6.49	0.09	01	0.6
100	6.65	0.09	01	0.6
100	6.8	0.13	01	0.6
100	6.81	0.13	01	0.6
100	6.98	0.13	01	0.6
100	7.15	0.13	01	0.6
100	7.32	0.13	01	0.6
100	7.5	0.13	01	0.6
100	7.68	0.13	01	0.6
100	7.87	0.13	01	0.6
100	8.06	0.13	01	0.6
100	8.2	0.13	01	0.6
100	8.25	0.13	01	0.6
100	8.45	0.13	01	0.6
100	8.66	0.13	01	0.6
100	8.87	0.13	01	0.6
100	9.09	0.13	01	0.6
100	9.1	0.13	01	0.6
100	9.31	0.13	01	0.6
100	9.53	0.13	01	0.6
100	9.76	0.13	01	0.6
100	10	0.13	01	0.6
100	10.2	0.13	01	0.6
100	10.5	0.13	01	0.6
100	10.7	0.13	01	0.6
100	11	0.13	01	0.6
100	11.3	0.13	01	0.6

DC Rated Voltage (U_R) Max (V)	Capacitance Value (C) (nF) (Note 1)	AC Rated Current (I_{RA}) Max (Arms)	Available Type Variant (See Para. 1.6)	Weight Max (g)
100	11.5	0.13	01	0.6
100	11.8	0.13	01	0.6
100	12	0.13	01	0.6
100	12.1	0.13	01	0.6
100	12.4	0.13	01	0.6
100	12.7	0.13	01	0.6
100	13	0.13	01	0.6
100	13.3	0.13	01	0.6
100	13.7	0.13	01	0.6
100	14	0.13	01	0.6
100	14.3	0.13	01	0.6
100	14.7	0.13	01	0.6
100	15	0.19	01	0.6
100	15.4	0.19	01	0.6
100	15.8	0.19	01	0.6
100	16	0.19	01	0.6
100	16.2	0.19	01	0.6
100	16.5	0.19	01	0.6
100	16.9	0.19	01	0.6
100	17.4	0.19	01	0.6
100	17.8	0.19	01	0.6
100	18	0.19	01	0.6
100	18.2	0.19	01	0.6
100	18.7	0.19	01	0.6
100	19.1	0.19	01	0.6
100	19.6	0.19	01	0.6
100	20	0.19	01	0.6
100	20.5	0.19	01	0.6
100	21	0.19	01	0.6
100	21.5	0.19	01	0.6
100	22	0.2	01	0.6
100	22.1	0.2	01	0.6
100	22.6	0.2	01	0.6
100	23.2	0.2	01	0.6
100	23.7	0.2	01	0.6
100	24	0.2	01	0.6
100	24.3	0.2	01	0.6
100	24.9	0.2	01	0.6
100	25.5	0.2	01	0.6
100	26.1	0.2	01	0.6

DC Rated Voltage (U_R) Max (V)	Capacitance Value (C) (nF) (Note 1)	AC Rated Current (I_{RA}) Max (Arms)	Available Type Variant (See Para. 1.6)	Weight Max (g)
100	26.7	0.2	01	0.6
100	27	0.2	01	0.6
100	27.4	0.2	01	0.6
100	28	0.2	01	0.6
100	28.7	0.2	01	0.6
100	29.4	0.2	01	0.6
100	30	0.2	01	0.6
100	30.1	0.2	01	0.6
100	30.9	0.2	01	0.6
100	31.6	0.2	01	0.6
100	32.4	0.2	01	0.6
100	33	0.26	01	0.6
100	33.2	0.26	01	0.6
100	34	0.26	01	0.6
100	34.8	0.26	01	0.6
100	35.7	0.26	01	0.6
100	36	0.26	01	0.6
100	36.5	0.26	01	0.6
100	37.4	0.26	01	0.6
100	38.3	0.26	01	0.6
100	39	0.26	01	0.6
100	39.2	0.26	01	0.6
100	40.2	0.26	01	0.6
100	41.2	0.26	01	0.6
100	42.2	0.26	01	0.6
100	43	0.26	01	0.6
100	43.2	0.26	01	0.6
100	44.2	0.26	01	0.6
100	45.3	0.26	01	0.6
100	46.4	0.26	01	0.6
100	47	0.26	01	0.6
100	47.5	0.26	01	0.6
100	48.7	0.26	01	0.6
100	49.9	0.26	01	0.6
100	51	0.26	01	0.6
100	51.1	0.26	01	0.6
100	52.3	0.26	01	0.6
100	53.6	0.26	01	0.6
100	54.9	0.26	01	0.6
100	56	0.26	01	0.6

DC Rated Voltage (U_R) Max (V)	Capacitance Value (C) (nF) (Note 1)	AC Rated Current (I_{RA}) Max (Arms)	Available Type Variant (See Para. 1.6)	Weight Max (g)
100	56.2	0.26	01	0.6
100	57.6	0.26	01	0.6
100	59	0.26	01	0.6
100	60.4	0.26	01	0.6
100	61.9	0.26	01	0.6
100	62	0.26	01	0.6
100	63.4	0.26	01	0.6
100	64.9	0.26	01	0.6
100	66.5	0.26	01	0.6
100	68	0.38	01	0.6
100	68.1	0.38	01	0.6
100	69.8	0.38	01	0.6
100	71.5	0.38	01	0.6
100	73.2	0.38	01	0.6
100	75	0.38	01	0.6
100	76.8	0.38	01	0.6
100	78.7	0.38	01	0.6
100	80.6	0.38	01	0.6
100	82	0.38	01	0.6
100	82.5	0.38	01	0.6
100	84.5	0.38	01	0.6
100	86.6	0.38	01	0.6
100	88.7	0.38	01	0.6
100	90.9	0.38	01	0.6
100	91	0.38	01	0.6
100	93.1	0.38	01	0.6
100	95.3	0.38	01	0.6
100	97.6	0.38	01	0.6
100	100	0.41	01	0.6
100	102	0.41	02	0.9
100	105	0.41	02	0.9
100	107	0.41	02	0.9
100	110	0.41	02	0.9
100	113	0.41	02	0.9
100	115	0.41	02	0.9
100	118	0.41	02	0.9
100	120	0.41	02	0.9
100	121	0.41	02	0.9
100	124	0.41	02	0.9
100	127	0.41	02	0.9

DC Rated Voltage (U_R) Max (V)	Capacitance Value (C) (nF) (Note 1)	AC Rated Current (I_{RA}) Max (Arms)	Available Type Variant (See Para. 1.6)	Weight Max (g)
100	130	0.41	02	0.9
100	133	0.41	02	0.9
100	137	0.41	02	0.9
100	140	0.41	02	0.9
100	143	0.41	02	0.9
100	147	0.41	02	0.9
100	150	0.84	02	0.9
100	154	0.84	02	0.9
100	158	0.84	02	0.9
100	160	0.84	02	0.9
100	162	0.84	02	0.9
100	165	0.84	02	0.9
100	169	0.84	02	0.9
100	174	0.84	02	0.9
100	178	0.84	02	0.9
100	180	0.84	02	0.9
100	182	0.84	02	0.9
100	187	0.84	02	0.9
100	191	0.84	02	0.9
100	196	0.84	02	0.9
100	200	0.84	02	0.9
100	205	0.84	02	0.9
100	210	0.84	02	0.9
100	215	0.84	02	0.9
100	220	0.91	02	0.9
100	221	0.91	03	1.3
100	226	0.91	03	1.3
100	232	0.91	03	1.3
100	237	0.91	03	1.3
100	240	0.91	03	1.3
100	243	0.91	03	1.3
100	249	0.91	03	1.3
100	255	0.91	03	1.3
100	261	0.91	03	1.3
100	267	0.91	03	1.3
100	270	0.91	03	1.3
100	274	0.91	03	1.3
100	280	0.91	03	1.3
100	287	0.91	03	1.3
100	294	0.91	03	1.3

DC Rated Voltage (U_R) Max (V)	Capacitance Value (C) (nF) (Note 1)	AC Rated Current (I_{RA}) Max (Arms)	Available Type Variant (See Para. 1.6)	Weight Max (g)
100	300	0.91	03	1.3
100	301	0.91	03	1.3
100	309	0.91	03	1.3
100	316	0.91	03	1.3
100	324	0.91	03	1.3
100	330	1.19	03	1.3
100	332	1.19	03	1.3
100	340	1.19	03	1.3
100	348	1.19	03	1.3
100	357	1.19	03	1.3
100	360	1.19	03	1.3
100	365	1.19	03	1.3
100	374	1.19	03	1.3
100	383	1.19	03	1.3
100	390	1.19	03	1.3
100	392	1.19	03	1.3
100	402	1.19	03	1.3
100	412	1.19	03	1.3
100	422	1.19	03	1.3
100	430	1.19	03	1.3
100	432	1.19	03	1.3
100	442	1.19	03	1.3
100	453	1.19	03	1.3
100	464	1.19	03	1.3
100	470	1.3	03	1.3

NOTES:

1. Capacitance Tolerances are available as follows:
 - $\pm 10\%$ for E12 Series Capacitance Values
 - $\pm 5\%$ for E24 Series Capacitance Values
 - $\pm 2\%$ for E48 Series Capacitance Values
 - $\pm 1\%$ for E96 Series Capacitance Values

1.5 **MAXIMUM RATINGS**

The maximum ratings shall not be exceeded at any time during use or storage.

Maximum ratings shall only be exceeded during testing to the extent specified in this specification and when stipulated in Test Methods and Procedures of the ESCC Generic Specification.

Characteristics	Symbols	Maximum Ratings	Units	Remarks
DC Rated Voltage	U_R	50, 100	V	Note 1
AC Rated Voltage	U_A	$35\%U_R$	V _{rms}	50/60Hz
AC Rated Current	I_{RA}	See Para. 1.4.2.2	A _{rms}	100kHz
Operating Temperature Range	T_{op}	-55 to +125	°C	T_{amb}
Storage Temperature Range	T_{stg}	-55 to +125	°C	
Soldering Temperature	T_{sol}	+215	°C	Note 2

NOTES:

- As required; See Para. 1.4.2.2.
- For reflow (vapour phase) soldering following a pre-heating phase at +130°C maximum:
 - Temperature: +215°C
 - Duration: 20s minimum, 40s maximum.

1.6 **PHYSICAL DIMENSIONS**

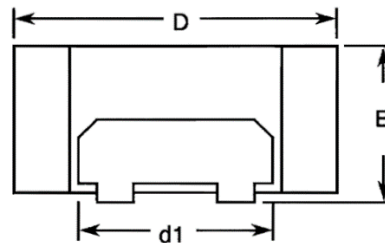
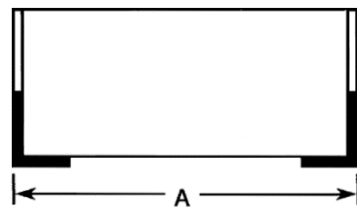
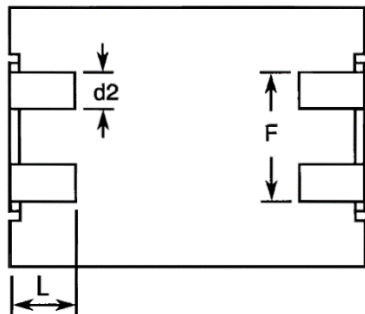

Type Variant	Dimensions (mm)										
	A Max	B Max	D Max	d1		d2		F		L	
				Min	Max	Min	Max	Min	Max	Min	Max
01	8	4.5	7.5	3.5	4.5	0.8	1.2	3.8	4.2	1.5	2.5
02	8	7.5	8.5	3.5	4.5	0.8	1.2	3.8	4.2	1.5	2.5
03	10.7	7.5	10.7	3.5	4.5	1.3	1.8	4.8	5.2	1.5	2.5

1.7 FUNCTIONAL DIAGRAM



2 REQUIREMENTS

2.1 GENERAL

The complete requirements for procurement of the components specified herein are as stated in this specification and the ESCC Generic Specification. Permitted deviations from the Generic Specification, applicable to this specification only, are listed below.

Permitted deviations from the Generic Specification and this Detail Specification, formally agreed with specific Manufacturers on the basis that the alternative requirements are equivalent to the ESCC requirement and do not affect the component's reliability, are listed in the appendices attached to this specification.

2.1.1 Deviations from the Generic Specification

2.1.1.1 *Deviations from Qualification and Periodic Tests – Chart F4*

(a) Mounting:

Prior to the commencement of Chart F4 Subgroups 1A, 1B, 2A and 2B, components may be mounted on a suitable substrate in accordance with IEC Publication No. 60384-1, Clause 5.5. After mounting, a force of 10N shall be applied normal to a line joining the terminals and, in a plane parallel to the substrate for a duration of 10s. There shall be no evidence of damage or loosening of the components from the substrate.

(b) Operating Life, Test Condition (c), Applied voltage: $1.25 \times U_R$

(c) Solderability shall be performed in accordance with IEC Publication No. 60068-2-58. The following details shall apply:

- Test Conditions:

- Temperature: $+215 \pm 3^\circ\text{C}$
- Immersion time: $3 \pm 0.3\text{s}$
- Immersion distance: 1mm minimum, 2mm maximum.

(d) Resistance to Soldering Heat shall be performed in accordance with IEC Publication No. 60068-2-58. The following details shall apply:

- Test Conditions:

- Temperature: $+215 \pm 3^\circ\text{C}$
- Immersion time: 40s
- Immersion distance: 1mm minimum, 2mm maximum.

- Data Points: As defined in Resistance to Soldering Heat in the Generic Specification.

2.2 MARKING

The marking shall be in accordance with the requirements of ESCC Basic Specification No. 21700 and as follows.

The information to be marked on the component or its primary package shall be:

- (a) The ESCC qualified components symbol (for ESCC qualified components only).
- (b) The ESCC Component Number (see Para. 1.4.1).
- (c) Traceability information.

2.3 ROBUSTNESS OF TERMINATIONS

The terminals of the components are rigid.

The test conditions for Robustness of Terminations shall be as specified in the ESCC Generic Specification and as follows:

- Test U_a, with an applied force of 10N and a duration of 10 ±1s.

Both terminals of the component shall be tested.

2.4 ELECTRICAL MEASUREMENTS AT ROOM, HIGH AND LOW TEMPERATURES

Electrical measurements shall be performed at room, high and low temperatures.

2.4.1 Room Temperature Electrical Measurements

The measurements shall be performed at T_{amb} = +22 ±3°C.

Characteristics	Symbols	Test Method and Conditions	Limits		Units
			Min	Max	
Capacitance	C	ESCC No. 3006 Test Frequency = 1kHz	Note 1	Note 2	nF
Tangent of Loss Angle	tgδ	ESCC No. 3006 Test Frequency = 1kHz	-	20×10 ⁻⁴	-
Insulation Resistance, Dielectric	R _I	ESCC No. 3006 C ≤ 330nF: C > 330nF:	30 10	- -	GΩ GΩ.nF
Insulation Resistance, Body Insulation	R _{IB}	ESCC No. 3006	50	-	GΩ
Voltage Proof, Terminal-to-Terminal	VP	ESCC No. 3006	1.6×U _R (Note 3)	-	V
Voltage Proof, Terminal-to-Case	VP _B	ESCC No. 3006	1.6×U _R (Note 3)	-	V

NOTES:

1. Capacitance Value of the component minus the applicable Tolerance (see Para. 1.4.2.2).
2. Capacitance Value of the component plus the applicable Tolerance (see Para. 1.4.2.2).
3. For the applicable Rated Voltage (U_R) see Para. 1.4.2.2.

2.4.2 High and Low Temperatures Electrical Measurements

Characteristics	Symbols	Test Method and Conditions (Note 1)	Limits		Units
			Min	Max	
Temperature Coefficient	$\Delta C/C$	ESCC No. 3006 Test Frequency = 1kHz $T_{amb} = -55 \pm 2^{\circ}C$:	-3 (Note 2)	+3 (Note 2)	%
		$T_{amb} = +125 \pm 2^{\circ}C$:	-3 (Note 2)	+3 (Note 2)	%

NOTES:

1. The measurements shall be performed on a sample of 6 components from each manufacturing lot with 0 failures allowed. In the event of any failure a 100% inspection may be performed.
2. The Temperature Coefficient limits are with respect to the capacitance at $+22 \pm 2^{\circ}C$ (reference point temperature).

2.5 INTERMEDIATE AND END-POINT ELECTRICAL MEASUREMENTS

Unless otherwise specified, the measurements shall be performed at $T_{amb} = +22 \pm 3^{\circ}C$.

Unless otherwise specified the test methods and test conditions shall be as per the corresponding test defined in Para. 2.4.1, Room Temperature Electrical Measurements.

Test Reference per ESCC No. 3006	Characteristics	Symbols	Limits		Units
			Min	Max	
Resistance to Soldering Heat Initial Measurements Final Measurements	Capacitance	C	Note 1		nF
	Capacitance	C	Note 1		nF
	Change in Capacitance	$\Delta C/C$	-2	+2	%
	Insulation Resistance, Dielectric	R_i			
	$C \leq 330nF$ $C > 330nF$		Note 1 Note 1	- -	G Ω G $\Omega.nF$
	Tangent of Loss Angle	$tg\delta$	-	Note 1	-
Temperature Coefficient	Temperature Coefficient (Note 2)	$\Delta C/C$	Note 3		%
Rapid Change of Temperature Initial Measurements Final Measurements	Capacitance	C	Note 1		nF
	Capacitance	C	Note 1		nF
	Change in Capacitance	$\Delta C/C$	-1	+1	%
	Tangent of Loss Angle	$tg\delta$	-	Note 1	-

Test Reference per ESCC No. 3006	Characteristics	Symbols	Limits		Units
			Min	Max	
Climatic Sequence					
Initial Measurements	Capacitance	C	Note 1		nF
Final Measurements	Capacitance	C	Note 1		nF
	Change in Capacitance	$\Delta C/C$	-1	+1	%
	Tangent of Loss Angle	$\text{tg}\delta$	-	50×10^{-4}	-
	Voltage Proof, Terminal-to-Terminal	VP	Note 1	-	V
	Voltage Proof, Terminal-to-Case	VP _B	Note 4	-	V
	Insulation Resistance, Dielectric	R _i			
		C ≤ 330nF:	Note 5	-	GΩ
		C > 330nF:	Note 5	-	GΩ.nF
	Insulation Resistance, Body Insulation	R _{IB}	Note 5	-	GΩ
Operating Life					
Initial Measurements	Capacitance	C	Note 1		nF
Intermediate Measurements (1000 hours)	Capacitance	C	Note 1		nF
	Change in Capacitance	$\Delta C/C$	-2	+2	%
Final Measurements (1000 or 2000 hours) (Note 6)	Capacitance	C	Note 1		nF
	Change in Capacitance	$\Delta C/C$	-2	+2	%
	Tangent of Loss Angle	$\text{tg}\delta$	-	Note 7	-
	Insulation Resistance, Dielectric	R _i			
		C ≤ 330nF:	Note 5	-	GΩ
	C > 330nF:	Note 5	-	GΩ.nF	
	Insulation Resistance, Body Insulation	R _{IB}	Note 5	-	GΩ

NOTES:

- As specified in Para. 2.4.1.
- The test method and test conditions shall be as specified in Para. 2.4.2.
- As specified in Para. 2.4.2.
- 1.6×U_R or 200V, whichever is greater. For the applicable Rated Voltage (U_R) see Para. 1.4.2.2.
- 50% of the limit specified in Para. 2.4.1.
- 1000 hours is applicable to Periodic Testing for extension of qualification. 2000 hours is applicable to Qualification Testing, and to Periodic Testing for renewal of qualification after lapse.
- 2× the limit specified in Para. 2.4.1.

2.6

BURN-IN CONDITIONS

Characteristics	Symbols	Conditions (Note 1)	Units
Ambient Temperature	T_{amb}	+125 (+0 -5)	°C
Test Voltage	V_T	$1.25 \times U_R$ (Note 2)	V

NOTES:

1. On completion of Burn-in the components shall be removed from the burn-in chamber and allowed to cool, under normal atmospheric conditions, for recovery for 24 ± 2 hours.
2. For the applicable Rated Voltage (U_R) see Para. 1.4.2.2.

APPENDIX 'A'
AGREED DEVIATIONS FOR EXXELIA TECHNOLOGIES (F)

Items Affected	Description of Deviations
Para. 2.1.1, Deviations from the Generic Specification: Deviations from Screening Tests – Chart F3	<p>If a particular lot is required to undergo testing in accordance with Chart F4 then the results of the Temperature Coefficient measurements, made during High and Low Temperatures Electrical Measurements on a sample of 6 randomly-selected capacitors, shall be recorded.</p> <p>These measurements may also be performed at the end of Chart F3 in order that the sample of components can include any components which passed post-Burn-in Room Temperature Electrical Measurements but subsequently failed External Visual Inspection.</p>
Para. 2.1.1.1, Deviations from Qualification and Periodic Tests – Chart F4	<p>Robustness of Terminations shall be performed as follows: The components shall be mounted on a suitable substrate. After mounting, examination shall be made for good tinning as evidenced by flowing of the solder with wetting of the terminations. A force of 10N shall be applied normal to the line joining the terminals and, in a plane parallel to the substrate, for a duration of 10 ±1s. The components shall then be examined and there shall be no evidence of damage or loosening of the components from the substrate.</p> <p>The Temperature Coefficient measurements recorded during Screening Tests may be used in lieu of the performance of the Temperature Coefficient test as specified in Subgroup 2B of Chart F4.</p>