



**CONNECTORS, ELECTRICAL, RECTANGULAR,
MICROMINIATURE, HIGH DATA RATE
(FEMALE COAXIAL CONTACTS)**

BASED ON TYPES AXOMACH AND SPACEFIBRE

ESCC Detail Specification No. 3401/089

Issue 4	December 2023
---------	---------------



LEGAL DISCLAIMER AND COPYRIGHT

European Space Agency, Copyright © 2023. All rights reserved.

The European Space Agency disclaims any liability or responsibility, to any person or entity, with respect to any loss or damage caused, or alleged to be caused, directly or indirectly by the use and application of this ESCC publication.

This publication, without the prior permission of the European Space Agency and provided that it is not used for a commercial purpose, may be:

- copied in whole, in any medium, without alteration or modification.
- copied in part, in any medium, provided that the ESCC document identification, comprising the ESCC symbol, document number and document issue, is removed.

DOCUMENTATION CHANGE NOTICE

(Refer to <https://escies.org> for ESCC DCR content)

DCR No.	CHANGE DESCRIPTION
1600	Specification updated to incorporate changes per DCR.

TABLE OF CONTENTS

1	GENERAL	5
1.1	SCOPE	5
1.2	COMPONENT TYPE VARIANTS AND RANGE OF COMPONENTS	5
1.3	MAXIMUM RATINGS	5
1.4	PARAMETER DERATING INFORMATION	5
1.5	PHYSICAL DIMENSIONS	5
2	APPLICABLE DOCUMENTS	24
3	TERMS, DEFINITIONS, ABBREVIATIONS, SYMBOLS AND UNITS	24
4	REQUIREMENTS	24
4.1	GENERAL	24
4.2	DEVIATIONS FROM THE GENERIC SPECIFICATION	24
4.2.1	Deviations from Special In-Process Controls	24
4.2.2	Deviations from Final Production Tests - Chart II(b)	24
4.2.3	Deviations from Burn-in and Electrical Measurements - Chart III	24
4.2.4	Deviations from Qualification Tests – Chart IV	25
4.2.5	Deviations from Lot Acceptance Tests – Chart V	25
4.3	MECHANICAL REQUIREMENTS	25
4.3.1	Dimension Check	25
4.3.2	Weight	25
4.3.3	Contact Retention (in Insert)	25
4.3.4	Mating and Unmating Forces	26
4.3.5	Insert Retention (in Shell)	26
4.3.6	Solderability	26
4.4	MATERIALS AND FINISHES	26
4.5	MARKING	26
4.5.1	General	26
4.5.2	The ESCC Component Number	27
4.6	ELECTRICAL MEASUREMENTS AT ROOM TEMPERATURE	27
4.7	ENVIRONMENTAL AND ENDURANCE TESTS (CHARTS IV AND V OF ESCC GENERIC SPECIFICATION NO. 3401)	28
	APPENDIX A	32

1 GENERAL

1.1 SCOPE

This specification details the ratings, physical and electrical characteristics, test and inspection data for Electrical, Rectangular, Microminiature, High Data Rate Connectors (with Female Coaxial Contacts), based on types AxoMach and SpaceFibre.

It shall be read in conjunction with:

- ESCC Generic Specification No. [3401](#), Connectors, Electrical, Rectangular and Circular. the requirements of which are supplemented herein.

1.2 COMPONENT TYPE VARIANTS AND RANGE OF COMPONENTS

The different physical configurations of the basic type connectors specified herein are scheduled in Table 1(a).

1.3 MAXIMUM RATINGS

The maximum ratings, which shall not be exceeded at any time during use or storage, applicable to the connectors specified herein, are given in Table 1(b).

1.4 PARAMETER DERATING INFORMATION

The derating information applicable to the connectors specified herein is shown in Figure 1.

1.5 PHYSICAL DIMENSIONS

The physical dimensions and characteristics of the connectors specified herein are shown in Figure 2.

TABLE 1(a) – COMPONENT TYPE VARIANTS AND RANGE OF COMPONENTS

Variant Number	Description	Physical Configuration	Weight Max (g)
01	AxoMach HDR, 1 Way, Female, Panel Mount Receptacle with Pin PCB Terminations	See Figure 2(a)	3
02	AxoMach HDR, 2 Way, Female, Panel Mount Receptacle with Pin PCB Terminations	See Figure 2(b)	5
03	AxoMach HDR, 4 Way, Female, Panel Mount Receptacle with Pin PCB Terminations	See Figure 2(c)	7
04	SpaceFibre HDR, Female, Panel Mount Receptacle with Pin PCB Terminations	See Figure 2(d)	4
05	AxoMach HDR, 1 Way, Female, SMD Receptacle with Hand-formable Coaxial Cable PCB Terminations	See Figure 2(e)	5.5 (Note 1)
06	AxoMach HDR, 2 Way, Female, SMD Receptacle with Hand-formable Coaxial Cable PCB Terminations	See Figure 2(f)	8.4 (Note 1)
07	AxoMach HDR, 4 Way, Female, SMD Receptacle with Hand-formable Coaxial Cable PCB Terminations	See Figure 2(g)	14.2 (Note 1)
08	SpaceFibre HDR, Female, SMD Receptacle with Hand-formable Coaxial Cable PCB Terminations	See Figure 2(h)	7.4 (Note 1)

NOTES:

1. Includes the weight of the connector plus the cable terminations (0.85g max each).

TABLE 1(b) - MAXIMUM RATINGS

Characteristics	Symbols	Maximum Ratings	Units	Remarks
Maximum Operating Data Rate	DR_{max}	10	Gb/s	
Operating Frequency Range	f_R	≤ 10	GHz	
Working Voltage	U_R	150	Vrms	At sea level. Note 1. See Figure 1(a)
Rated Current	I_R	1	A	Each contact
Operating Temperature Range	T_{op}	-55 to +125	°C	T_{amb}
Storage Temperature Range	T_{stg}	-55 to +125	°C	
Soldering Temperature	T_{sol}	350	°C	

NOTES:

1. Between contacts, and contacts and shell.

FIGURE 1 - PARAMETER DERATING INFORMATION

FIGURE 1(a) - WORKING VOLTAGE VERSUS ALTITUDE

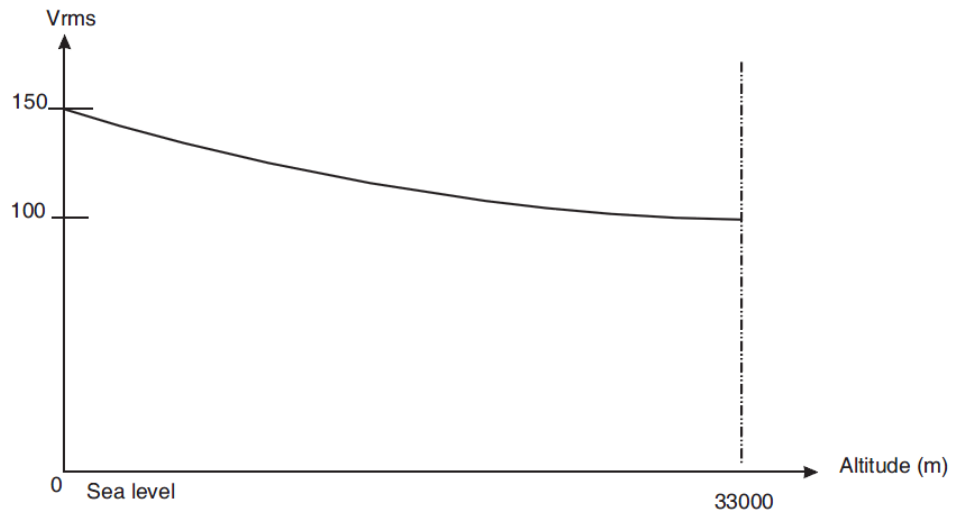
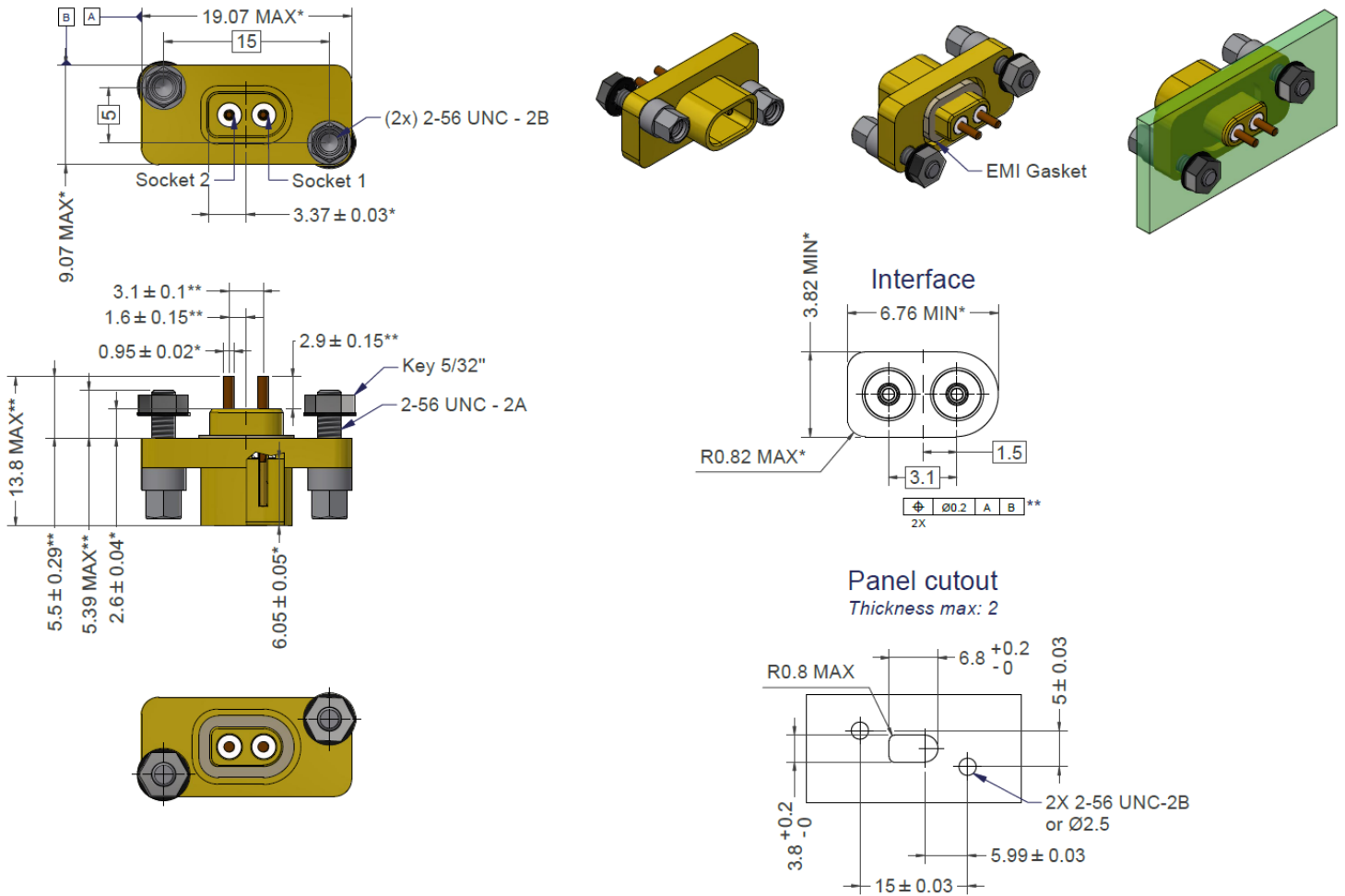

FIGURE 2 - PHYSICAL DIMENSIONS

FIGURE 2(a) – VARIANT 01 - AXOMACH HDR, 1 WAY, FEMALE, PANEL MOUNT RECEPTACLE WITH WITH PIN PCB TERMINATIONS



NOTES:

1. All dimensions are in mm.
2. Dimensions with a single asterisk (*) may be checked during the Manufacturer's internal processing. Dimensions with a double asterisk (**) shall be checked after assembly of the connector.
3. For connector interface dimensions, see also Figure 2(j).
4. Mounting jackpost nut torque: 0.35N.m (+10 -0)%.
5. Contact identification: contact (socket) Nos. 1 and 2 are indicated by the physical configuration (as shown above).
6. Maximum panel thickness: 2mm.
7. Nut thickness: 1.6mm.
8. Washer dimensions: 0.3mm x Ø4.7mm
9. Panel cut-out details are shown for information purposes only.

10. The following PCB layout is shown for information purposes only.
General tolerance: $\pm 0.1\text{mm}$.

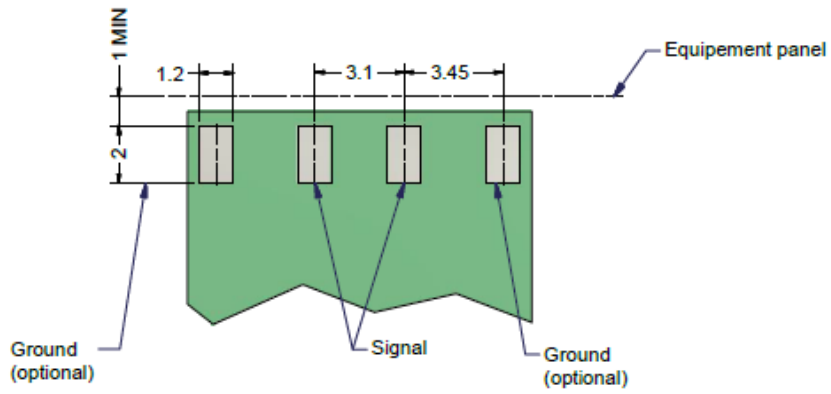
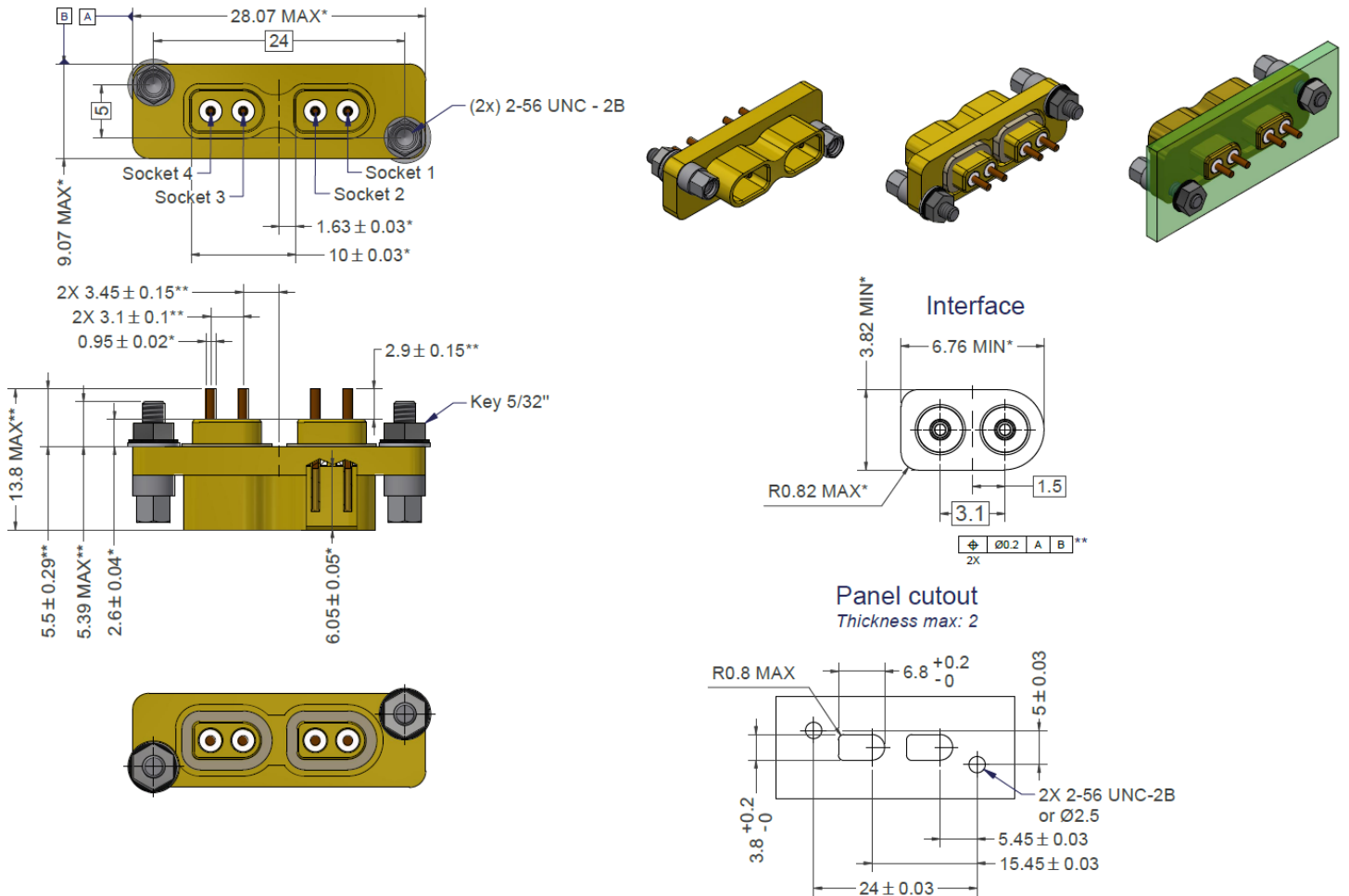

FIGURE 2(b) – VARIANT 02 - AXOMACH HDR, 2 WAY, FEMALE, PANEL MOUNT RECEPTACLE WITH PIN PCB TERMINATIONS



NOTES:

1. All dimensions are in mm.
2. Dimensions with a single asterisk (*) may be checked during the Manufacturer's internal processing. Dimensions with a double asterisk (**) shall be checked after assembly of the connector.
3. For connector interface dimensions, see also Figure 2(j).
4. Mounting jackpost nut torque: 0.35N.m (+10 -0)%.
5. Contact identification: contact (socket) Nos. 1 to 4 are indicated by the physical configuration (as shown above).
6. Maximum panel thickness: 2mm.
7. Nut thickness: 1.6mm.
8. Washer dimensions: 0.3mm x Ø4.7mm
9. Panel cut-out details are shown for information purposes only.

10. The following PCB layout is shown for information purposes only.
General tolerance: $\pm 0.1\text{mm}$.

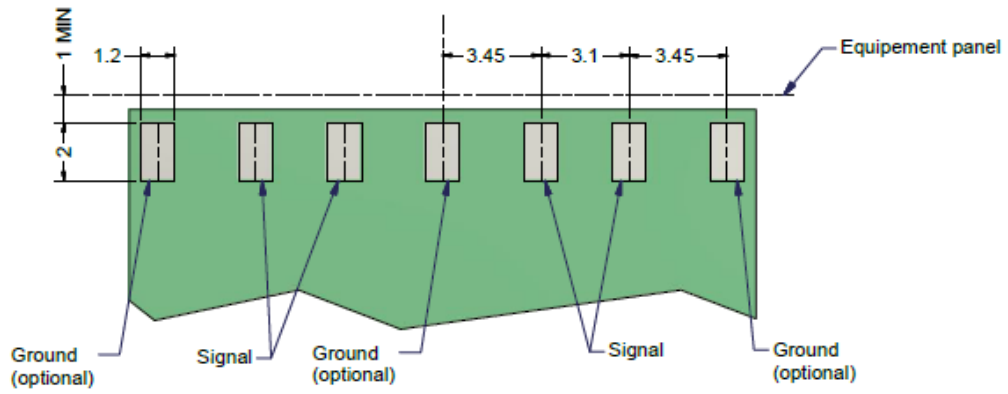
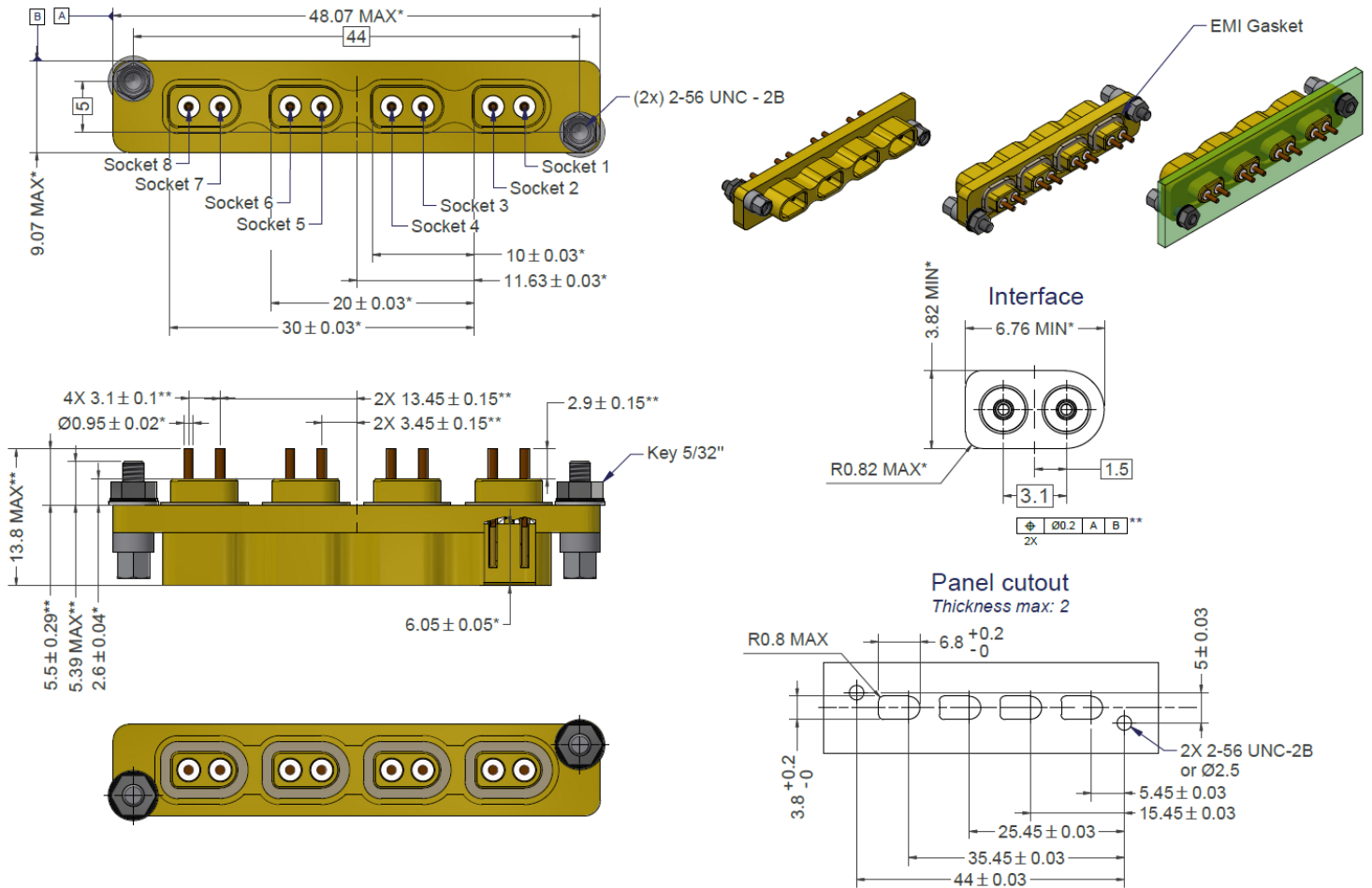

FIGURE 2(c) – VARIANT 03 - AXOMACH HDR, 4 WAY, FEMALE, PANEL MOUNT RECEPTACLE WITH PIN PCB TERMINATIONS



NOTES:

1. All dimensions are in mm.
2. Dimensions with a single asterisk (*) may be checked during the Manufacturer's internal processing. Dimensions with a double asterisk (**) shall be checked after assembly of the connector.
3. For connector interface dimensions, see also Figure 2(j).
4. Mounting jackpost nut torque: 0.35N.m (+10 -0)%.
5. Contact identification: contact (socket) Nos. 1 to 8 are indicated by the physical configuration (as shown above).
6. Maximum panel thickness: 2mm.
7. Nut thickness: 1.6mm.
8. Washer dimensions: 0.3mm x Ø4.7mm
9. Panel cut-out details are shown for information purposes only.

10. The following PCB layout is shown for information purposes only.
General tolerance: $\pm 0.1\text{mm}$.

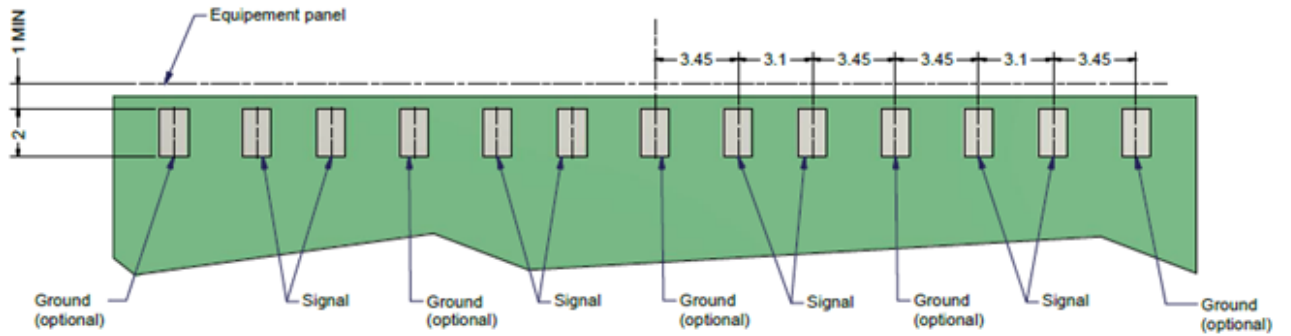
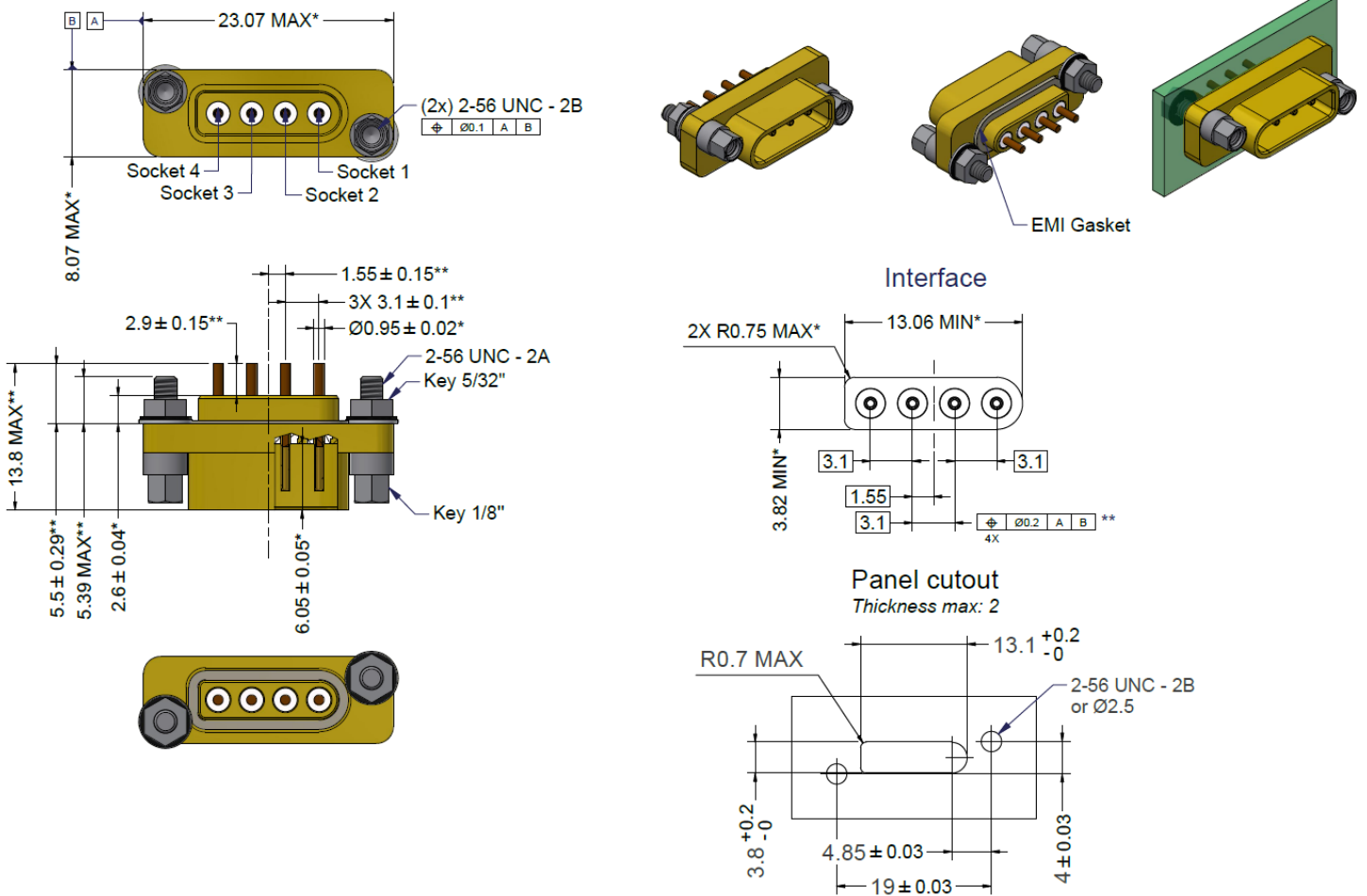

FIGURE 2(d) – VARIANT 04 - SPACEFIBRE HDR, FEMALE, PANEL MOUNT RECEPTACLE WITH PIN PCB TERMINATIONS



NOTES:

1. All dimensions are in mm.
2. Dimensions with a single asterisk (*) may be checked during the Manufacturer's internal processing. Dimensions with a double asterisk (**) shall be checked after assembly of the connector.
3. For connector interface dimensions, see also Figure 2(j).
4. Mounting jackpost nut torque: 0.35N.m (+10 -0)%.
5. Contact identification: contact (socket) Nos. 1 to 4 are indicated by the physical configuration (as shown above).
6. Maximum panel thickness: 2mm.
7. Nut thickness: 1.6mm.
8. Washer dimensions: 0.3mm x Ø4.7mm
9. Panel cut-out details are shown for information purposes only.

10. The following PCB layout is shown for information purposes only.
General tolerance: $\pm 0.1\text{mm}$.

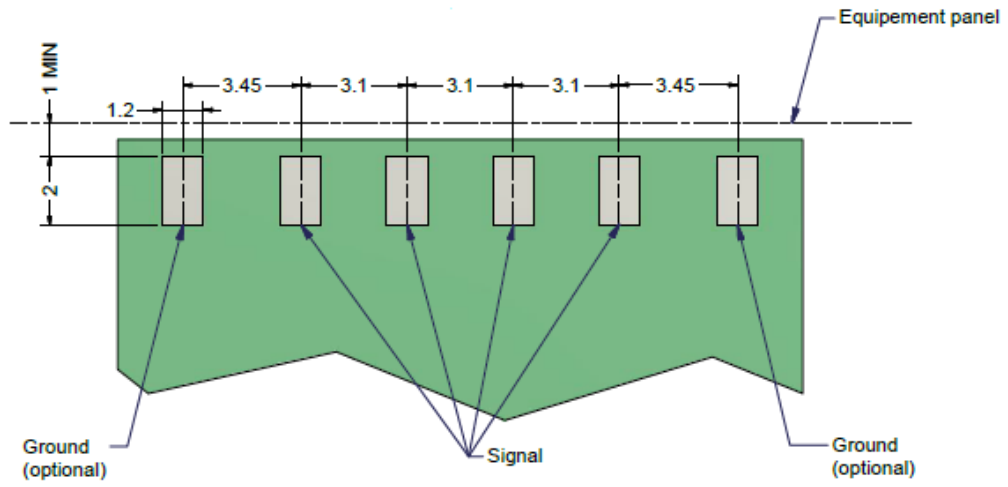
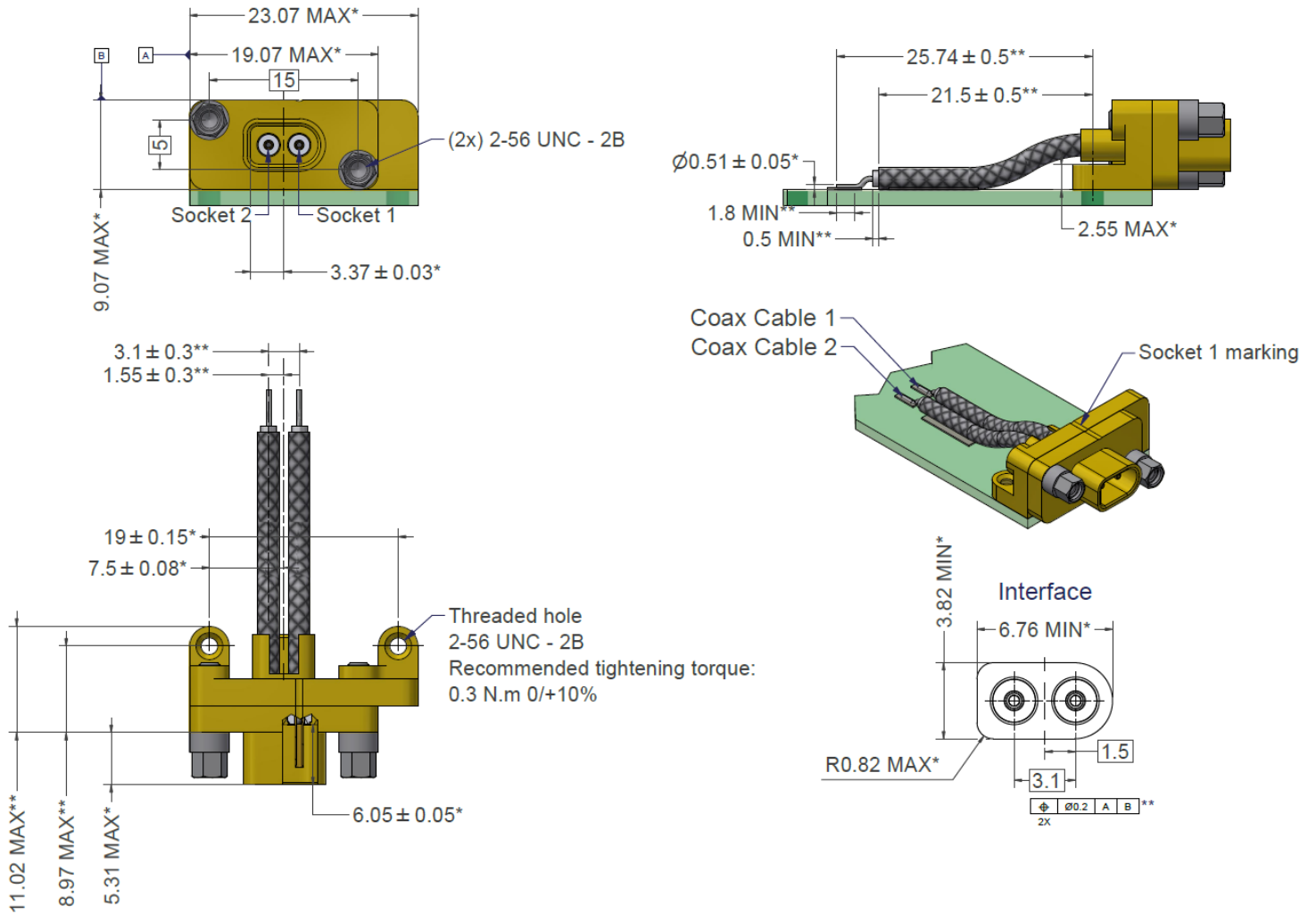

FIGURE 2(e) - VARIANT 05 - AXOMACH HDR, 1 WAY, FEMALE, SMD RECEPTACLE WITH HAND-FORMABLE COAXIAL CABLE PCB TERMINATIONS



NOTES:

1. All dimensions are in mm.
2. Dimensions with a single asterisk (*) may be checked during the Manufacturer's internal processing. Dimensions with a double asterisk (**) shall be checked after assembly of the connector.
3. For connector interface dimensions, see also Figure 2(j).
4. Cable termination outer diameter: 2.15 ± 0.1mm.
5. Mounting jackpost nut torque: 0.3N.m (+10 -0)%.
6. Contact and cable termination identification: Contact and cable Nos. 1 and 2 are indicated by the physical configuration. In addition, contact No. 1 and cable 1 No. 1 are indicated by an index mark on the shell above socket 1 (as shown above).

7. The following PCB layout is shown for information purposes only.
General tolerance: $\pm 0.1\text{mm}$.

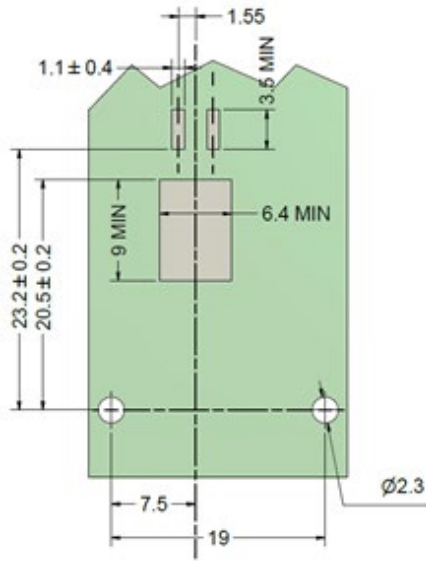
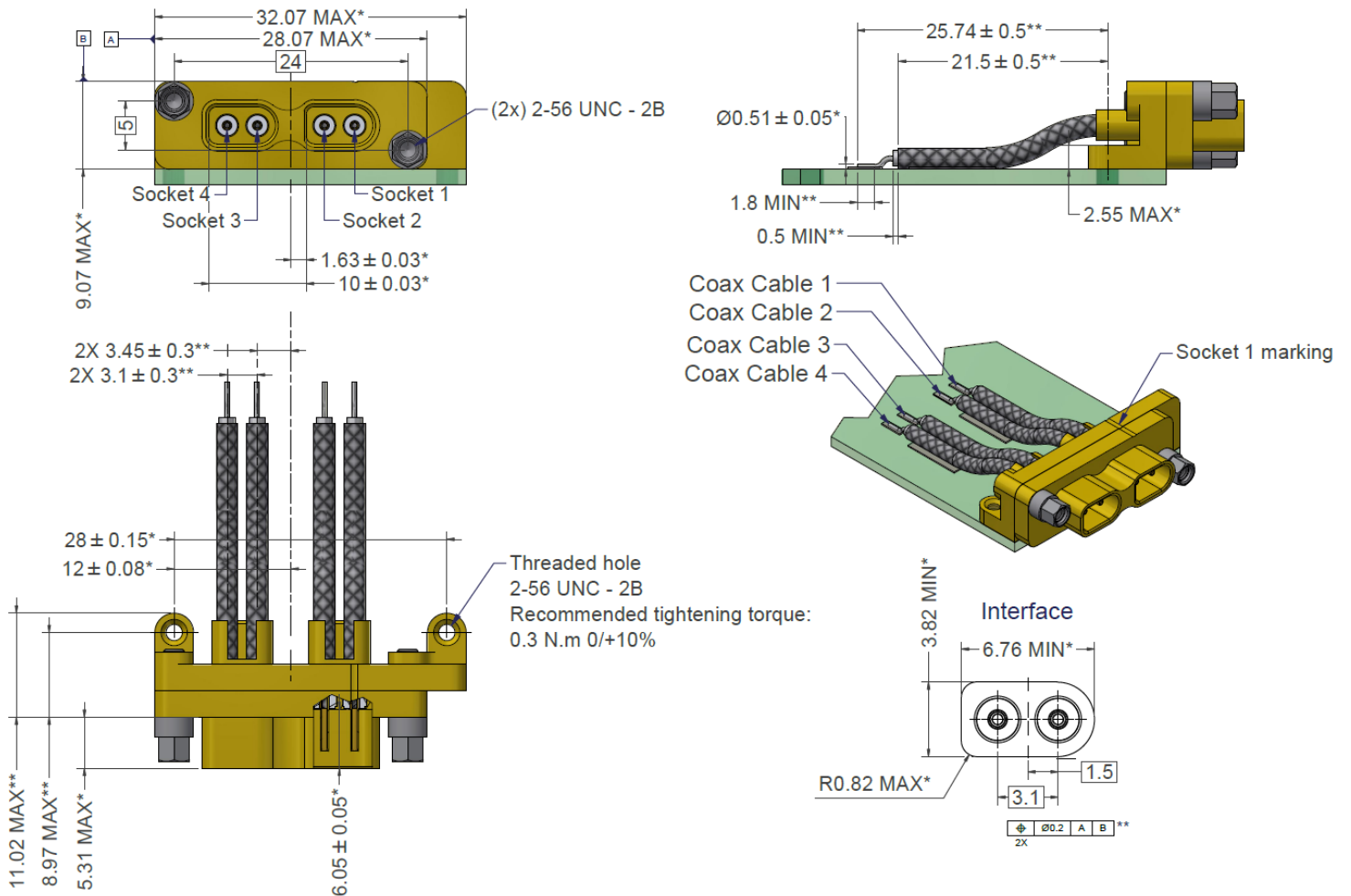

FIGURE 2(f) - VARIANT 06 - AXOMACH HDR, 2 WAY, FEMALE, SMD RECEPTACLE WITH HAND-FORMABLE COAXIAL CABLE PCB TERMINATIONS



NOTES:

1. All dimensions are in mm.
2. Dimensions with a single asterisk (*) may be checked during the Manufacturer's internal processing. Dimensions with a double asterisk (**) shall be checked after assembly of the connector.
3. For connector interface dimensions, see also Figure 2(j).
4. Cable termination outer diameter: 2.15 ± 0.1mm.
5. Mounting jackpost nut torque: 0.3N.m (+10 -0)%.
6. Contact and cable termination identification: Contact and cable Nos. 1 to 4 are indicated by the physical configuration. In addition, contact No. 1 and cable 1 No. 1 are indicated by an index mark on the shell above socket 1 (as shown above).

7. The following PCB layout is shown for information purposes only.
General tolerance: $\pm 0.1\text{mm}$.

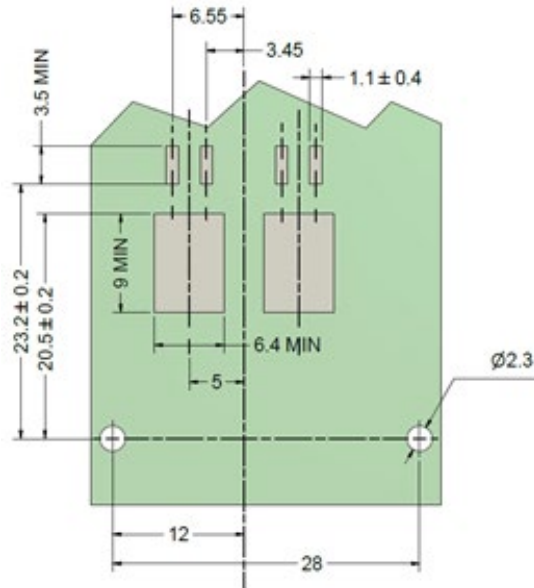
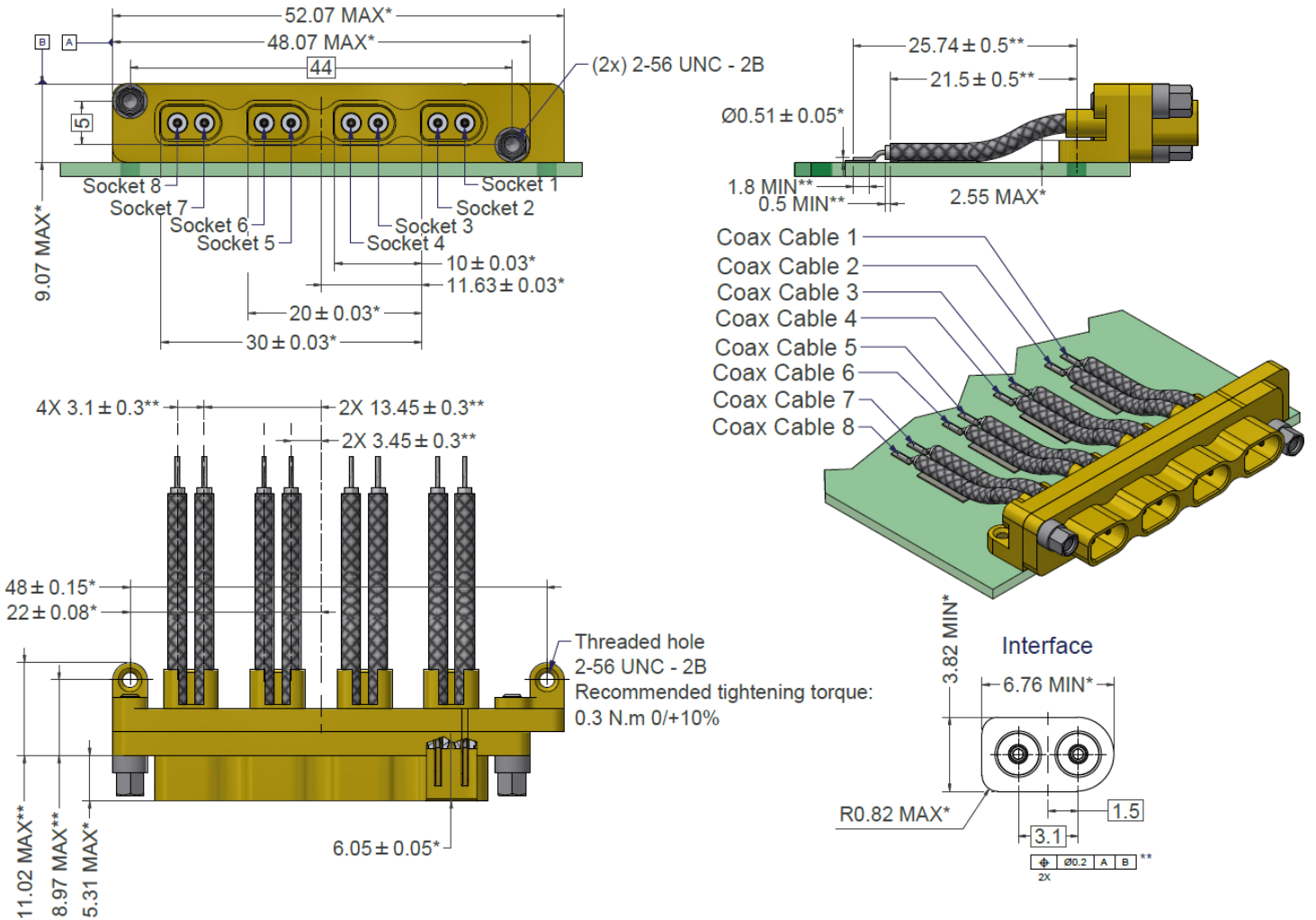

FIGURE 2(g) - VARIANT 07 - AXOMACH HDR, 4 WAY, FEMALE, SMD RECEPTACLE WITH HAND-FORMABLE COAXIAL CABLE PCB TERMINATIONS



NOTES:

1. All dimensions are in mm.
2. Dimensions with a single asterisk (*) may be checked during the Manufacturer's internal processing. Dimensions with a double asterisk (**) shall be checked after assembly of the connector.
3. For connector interface dimensions, see also Figure 2(j).
4. Cable termination outer diameter: 2.15 ± 0.1mm.
5. Mounting jackpost nut torque: 0.3N.m (+10 -0)%.
6. Contact and cable termination identification: Contact and cable Nos. 1 to 8 are indicated by the physical configuration. In addition, contact No. 1 and cable 1 No. 1 are indicated by an index mark on the shell above socket 1 (as shown above).

7. The following PCB layout is shown for information purposes only.
General tolerance: $\pm 0.1\text{mm}$.

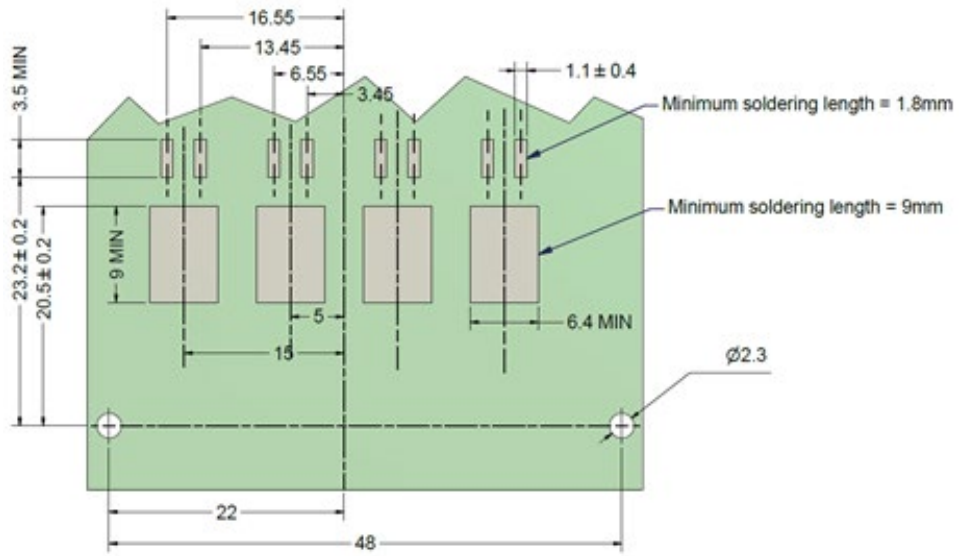
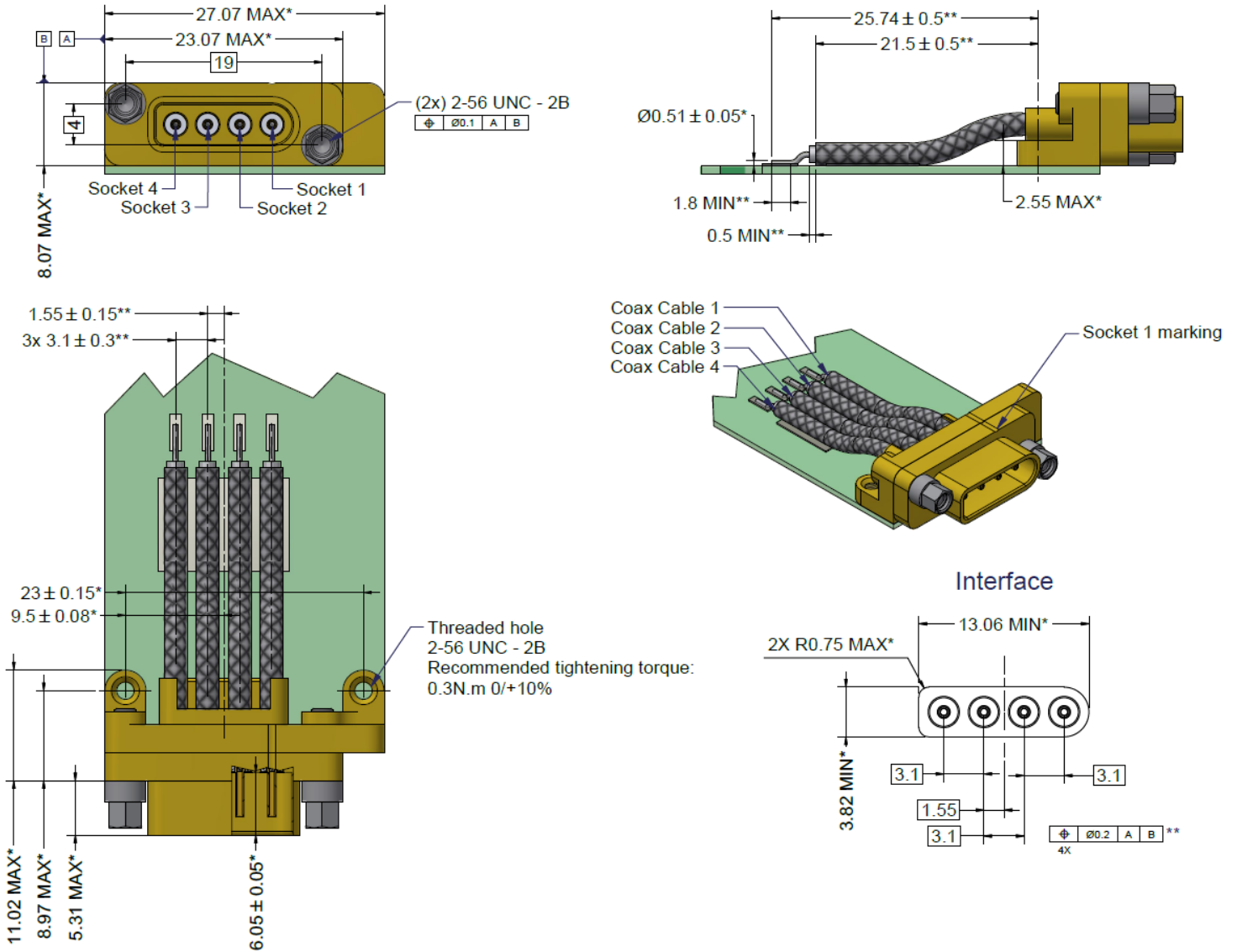

FIGURE 2(h) - VARIANT 08 - SPACEFIBRE HDR, FEMALE, SMD RECEPTACLE WITH HAND-FORMABLE COAXIAL CABLE PCB TERMINATIONS



NOTES:

1. All dimensions are in mm.
2. Dimensions with a single asterisk (*) may be checked during the Manufacturer's internal processing. Dimensions with a double asterisk (**) shall be checked after assembly of the connector.
3. For connector interface dimensions, see also Figure 2(j).
4. Cable termination outer diameter: 2.15 ± 0.1mm.
5. Mounting jackpost nut torque: 0.3N.m (+10 -0)%.
6. Contact and cable termination identification: Contact and cable Nos. 1 to 4 are indicated by the physical configuration. In addition, contact No. 1 and cable 1 No. 1 are indicated by an index mark on the shell above socket 1 (as shown above).

7. The following PCB layout is shown for information purposes only.
General tolerance: $\pm 0.1\text{mm}$.

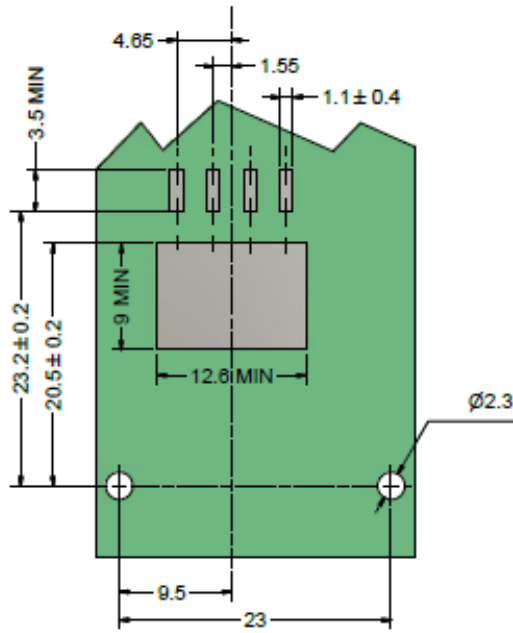
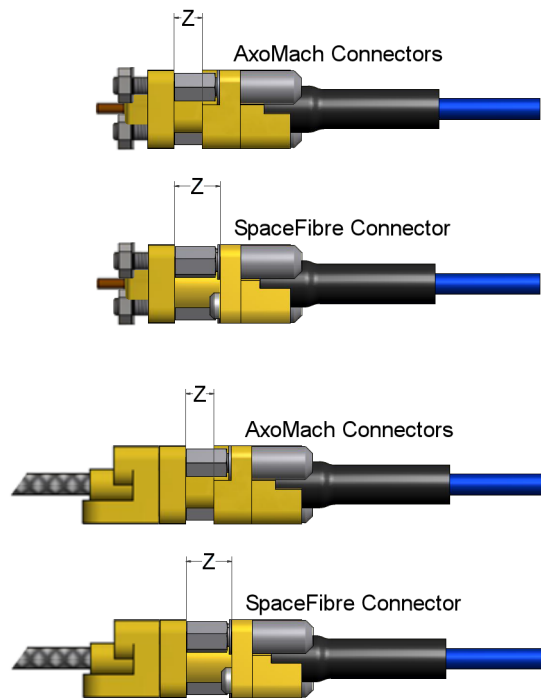

FIGURE 2(i) - MATED CONNECTOR DIMENSIONS

Examples:



Symbols	Dimensions mm		Remarks
	Min	Max	
Z	-	3.4	When mating Variants 01, 02, 03, 05, 06, 07 with male connectors per ESCC No. 3409/001 (AxoMach)
	-	5.4	When mating Variants 04, 08 with male connectors per ESCC No. 3409/001 (SpaceFibre)

FIGURE 2(j) - INTERFACE DIMENSIONS, RECEPTACLE, FEMALE CONTACT

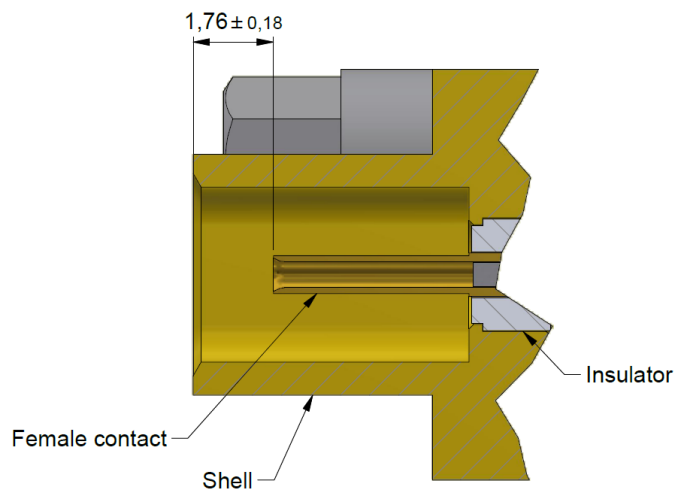

NOTES:

1. All dimensions are in mm.

2 **APPLICABLE DOCUMENTS**

The following documents form part of this specification and shall be read in conjunction with it:

- (a) ESCC Generic Specification No. [3401](#), Connectors, Electrical, Circular and Rectangular.
- (b) ESCC Generic Specification No. [3902](#), Cables, Coaxial, Radio Frequency, Flexible.
- (c) ESCC Detail Specification No. [3409/001](#), High Data Rate Cable Assembly with Microminiature, Rectangular, Coaxial Connectors based on types AxoMach and SpaceFibre.

3 **TERMS, DEFINITIONS, ABBREVIATIONS, SYMBOLS AND UNITS**

For the purpose of this specification, the terms, definitions, abbreviations, symbols and units specified in ESCC Basic Specification No. [21300](#) shall apply.

4 **REQUIREMENTS**

4.1 **GENERAL**

The complete requirements for procurement of the connectors specified herein are stated in this specification and ESCC Generic Specification No. [3401](#). Deviations from the Generic Specification, applicable to this specification only, are listed in Para. 4.2.

Deviations from the applicable Generic Specification and this Detail Specification, formally agreed with specific Manufacturers on the basis that the alternative requirements are equivalent to the ESCC requirements and do not affect the components' reliability, are listed in the appendices attached to this specification.

4.2 **DEVIATIONS FROM THE GENERIC SPECIFICATION**

4.2.1 **Deviations from Special In-Process Controls**

- (a) Crimping Capability: The minimum tensile strength shall be as follows:
 - Variants 01 to 04: 30N, using the pin termination that is crimped to the contact.
 - Variants 05 to 08: 60N, using the centre conductor of the cable termination that is crimped to the contact.
- (b) Solderability: Not applicable.

4.2.2 **Deviations from Final Production Tests - Chart II(b)**

- (a) Para. 9.4, Contact Capability: Not applicable.
- (b) Para. 9.9, Seal Test: Not applicable
- (c) Para. 9.5, Magnetism Level: Not applicable.

4.2.3 **Deviations from Burn-in and Electrical Measurements - Chart III**

None (Chart III is not applicable).

4.2.4 Deviations from Qualification Tests – Chart IV

- (a) Para. 9.9, Seal Test: Not applicable.
- (b) Para. 9.10, Wiring: Not applicable.
- (c) Para. 9.11, Vibration: Measurements and inspections shall be performed in accordance with Table 6 herein.
- (d) Para. 9.12, Shock or Bump: Measurements and inspections shall be performed in accordance with Table 6 herein.
- (e) Para. 9.13, Climatic Sequence: Measurements and inspections shall be performed in accordance with Table 6 herein.
- (f) Para. 9.15, Joint Strength: Not applicable.
- (g) Para. 9.16, Rapid Change of Temperature: Measurements and inspections shall be performed in accordance with Table 6 herein.
- (h) Para. 9.21, High Temperature Storage: Measurements and inspections shall be performed in accordance with Table 6 herein.
- (i) Para. 9.24, Jackscrew Retention: Not applicable.
- (j) Para. 9.25, High Temperature Measurements: Measurements and inspections shall be performed in accordance with Table 6 herein.
- (k) Para. 9.26, Overload Test: Not applicable.
- (l) Para. 9.27, Maintenance Aging: Not applicable.
- (m) Para. 9.28, Engagement and Separation Forces: Not applicable.
- (n) Para. 9.29, Oversize Pin Exclusion: Not applicable.
- (o) Para. 9.30, Probe Damage: Not applicable.

4.2.5 Deviations from Lot Acceptance Tests – Chart V

- (a) Para. 9.9, Seal Test: Not applicable.
- (b) Para. 9.10, Wiring: Not applicable.
- (c) Para. 9.13, Climatic Sequence: Measurements and inspections shall be performed in accordance with Table 6 herein.
- (d) Para. 9.15, Joint Strength: Not applicable.
- (e) Para. 9.16, Rapid Change of Temperature: Measurements and inspections shall be performed in accordance with Table 6 herein.
- (f) Para. 9.27, Maintenance Aging: Not applicable.
- (g) Para. 9.28, Engagement and Separation Forces: Not applicable.
- (h) Para. 9.29, Oversize Pin Exclusion: Not applicable.
- (i) Para. 9.30, Probe Damage: Not applicable.

4.3 MECHANICAL REQUIREMENTS

4.3.1 Dimension Check

See Figure 2.

4.3.2 Weight

See Table 1(a).

4.3.3 Contact Retention (in Insert)

Applied force: 14.8N.

4.3.4 Mating and Unmating Forces

Variant Number	Mating Force (N)	Unmating Force (N)	
	Max	Min	Max
01, 05	5.6	0.4	5.6
02, 04, 06, 08	11.2	0.8	11.2
03, 07	22.4	1.6	22.4

4.3.5 Insert Retention (in Shell)

Maximum load: 14.8N.

4.3.6 Solderability

Solderability shall be performed on the connector PCB terminations. A size B soldering iron shall be used.

4.4 MATERIALS AND FINISHES

The materials and finishes shall be as specified herein. Where a definite material is not specified, a material which will enable the components specified herein to meet the performance requirements of this specification shall be used. Acceptance or approval of any constituent material does not guarantee acceptance of the finished product.

- (a) Body Shell: Aluminium alloy, gold plated 2.54µm minimum over nickel underplate 25µm minimum.
- (b) Centre Contact: Copper alloy, gold plated 1.27µm minimum over nickel underplate 1.27µm minimum.
Note: measurements of plating thickness shall be made at 1.5mm from the engagement end.
- (c) Pin terminations: Copper alloy, gold plated 1.27µm minimum over nickel underplate 1.5µm minimum.
- (d) Cable terminations: Coaxial cable, ePTFE, hand-formable, 50Ω, type QFX086S in accordance with the requirements of ESCC Generic Specification No. [3902](#), and as follows:
 - Centre Conductor: Copper clad steel, silver plated 2µm minimum.
 - Dielectric Core: Extruded PTFE.
 - Shield: Copper braid, silver plated 2µm minimum.
- (e) Connector to backshell interface EMI seals: Conductive silicone-base rubber.
- (f) Insert (insulator): PTFE.
- (g) Locking devices: Passivated stainless steel.

4.5 MARKING

4.5.1 General

The marking shall be in accordance with the requirements of ESCC Basic Specification No. [21700](#) and as follows.

The information to be marked on the component or its primary package shall be:

- (a) The ESCC qualified components symbol (for ESCC qualified components only).
- (b) The ESCC Component Number.
- (c) Traceability Information.

4.5.2 The ESCC Component Number

The ESCC Component Number shall be constituted as follows:

Example: 340108901B

- Detail Specification Reference: 3401089
- Component Type Variant Number (see Table 1(a)): 01 (as required)
- Testing Level: B

4.6 ELECTRICAL MEASUREMENTS AT ROOM TEMPERATURE

The parameters to be measured in respect of electrical characteristics are scheduled in Table 2. Unless otherwise specified, the measurements shall be performed at $T_{amb} = +22 \pm 3^{\circ}C$.

TABLE 2 - ELECTRICAL MEASUREMENTS AT ROOM TEMPERATURE

Characteristics	Symbols	Test Method and Conditions	Limits		Units
			Min	Max	
Insulation Resistance	R _i	ESCC No. 3401 V = 500Vdc	5	-	GΩ
Voltage Proof Leakage Current	I _{VPL}	V = 600Vrms	-	2	mA
Contact Resistance (Low Level Current)	R _{CL}	ESCC No. 3401 Variants 01 02 03 04: Variants 05 06 07 08:	- -	6 10	mΩ
Contact Resistance (Rated Current)	R _{CR}	ESCC No. 3401 Variants 01 02 03 04: Variants 05 06 07 08:	- -	5 10	mΩ
Mated Shell Conductivity	R _M	ESCC No. 3401	-	5	mΩ

TABLES 3, 4, 5

Not applicable

4.7 ENVIRONMENTAL AND ENDURANCE TESTS (CHARTS IV AND V OF ESCC GENERIC SPECIFICATION No. 3401)

The parameters to be measured and inspections to be performed on completion of environmental and endurance testing shall be those specified in Table 6.

Unless otherwise specified, the measurements shall be performed at $T_{amb} = +22 \pm 3^{\circ}C$

Unless otherwise specified, test methods and test conditions shall be as per the corresponding test defined in Table 2.

TABLE 6 - MEASUREMENTS AND INSPECTIONS ON COMPLETION OF ENVIRONMENTAL AND ENDURANCE TESTING

ESCC Generic Spec. No. 3401		Measurements and Inspections		Symbol	Limits		Unit
Environmental and Endurance Tests (1)	Test Method and Conditions	Identification	Conditions		Min	Max	
Vibration	Para. 9.11	Initial Measurements					
		Coupling Screws Unlocking Torque	ESCC 3401	Tqe	Record Values		
		Insulation Resistance	Table 2	R _i	Table 2		
		Voltage Proof Leakage Current	Table 2	I _{VPL}	Table 2		
		Low Level Contact Resistance	Table 2	R _{CL}	Table 2		
		Mated Shell Conductivity	Table 2	R _M	Table 2		
		Measurements during Vibration					
		Monitor Contact Disturbance	ESCC 3401	-	-	1	μs
		Final Measurements					
		Coupling Screws Unlocking Torque Drift	ESCC 3401	ΔTqe/Tqe	-25	+25	% (2)
		Insulation Resistance	Table 2	R _i	Table 2		
		Voltage Proof Leakage Current	Table 2	I _{VPL}	Table 2		
		Voltage Proof Leakage Current Drift	Table 2	ΔI _{VPL}	-	+25	% (2)
		Low Level Contact Resistance	Table 2	R _{CL}	Table 2		
		Low Level Contact Resistance Drift	Table 2	ΔR _{CL}	-	+25	% (2)
Mated Shell Conductivity	Table 2	R _M	Table 2				
Mated Shell Conductivity Drift	Table 2	ΔR _M	-	+25	% (2)		
Visual Examination	ESCC 3401	-	-	-			

ESCC Generic Spec. No. 3401		Measurements and Inspections		Symbol	Limits		Unit
Environmental and Endurance Tests (1)	Test Method and Conditions	Identification	Conditions		Min	Max	
Shock or Bump	Para. 9.12	Initial Measurements (3)					
		Coupling Screws Unlocking Torque	ESCC 3401	Tqe	Record Values		
		Insulation Resistance	Table 2	R _i	Table 2		
		Voltage Proof Leakage Current	Table 2	I _{VPL}	Table 2		
		Low Level Contact Resistance	Table 2	R _{CL}	Table 2		
		Mated Shell Conductivity	Table 2	R _M	Table 2		
		Measurements during Vibration					
		Monitor Contact Disturbance	ESCC 3401	-	-	1	µs
		Final Measurements					
		Coupling Screws Unlocking Torque Drift	ESCC 3401	ΔTqe/Tqe	-25	+25	% (2)
		Insulation Resistance	Table 2	R _i	Table 2		
		Voltage Proof Leakage Current	Table 2	I _{VPL}	Table 2		
		Voltage Proof Leakage Current Drift	Table 2	ΔI _{VPL}	-	+25	% (2)
		Low Level Contact Resistance	Table 2	R _{CL}	Table 2		
Low Level Contact Resistance Drift	Table 2	ΔR _{CL}	-	+25	% (2)		
Mated Shell Conductivity	Table 2	R _M	Table 2				
Mated Shell Conductivity Drift	Table 2	ΔR _M	-	+25	% (2)		
Visual Examination	ESCC 3401	-	-	-			
Climatic Sequence	Para. 9.13	Initial Measurements (3)					
		Insulation Resistance	Table 2	R _i	Table 2		
		Voltage Proof Leakage Current	Table 2	I _{VPL}	Table 2		
		Low Level Contact Resistance	Table 2	R _{CL}	Table 2		
		Mated Shell Conductivity	Table 2	R _M	Table 2		
		Dry Heat					
		Insulation Resistance	Table 2 (at T _{amb} = +125°C)	R _i	5	-	GΩ
		Low Air Pressure					
		Voltage Proof Leakage Current	100Vrms	I _{VPL}	-	1	mA
		Damp Heat					
		Insulation Resistance	Table 2	R _i	100	-	MΩ
Final Measurements							
External Visual Inspection	ESCC 3401	-	-				
Insulation Resistance	Table 2	R _i	Table 2				
Voltage Proof Leakage Current	Table 2	I _{VPL}	Table 2				
Plating Thickness	Para. 9.14	Plating Thickness	-	-	Para. 4.4		

ESCC Generic Spec. No. 3401		Measurements and Inspections		Symbol	Limits		Unit
Environmental and Endurance Tests (1)	Test Method and Conditions	Identification	Conditions		Min	Max	
Rapid Change of Temperature	Para. 9.16	Initial Measurements Visual Examination Insulation Resistance Voltage Proof Leakage Current Low Level Contact Resistance Rated Current Contact Resistance Mated Shell Conductivity Final Measurements Visual Examination Insulation Resistance Voltage Proof Leakage Current Low Level Contact Resistance Rated Current Contact Resistance Mated Shell Conductivity	ESCC 3401 Table 2 Table 2 Table 2 Table 2 Table 2 ESCC 3401 Table 2 Table 2 Table 2 Table 2 Table 2	- R _I I _{VPL} R _{CL} R _{CR} R _M - R _I I _{VPL} R _{CL} R _{CR} R _M	- Table 2 Table 2 Table 2 Table 2 Table 2 - Table 2 Table 2 Table 2 Table 2 Table 2		
Contact Retention (in Insert)	Para. 9.17, and Para. 4.3.3 herein	Contact axial displacement	ESCC 3401	-	ESCC 3401		
Endurance	Para. 9.18	Initial Measurements Mating and Unmating Forces Low Level Contact Resistance Mated Shell Conductivity Final Measurements Visual Examination Mating and Unmating Forces Low Level Contact Resistance Low Level Contact Resistance Drift Insulation Resistance Voltage Proof Leakage Current Mated Shell Conductivity	ESCC 3401 Table 2 Table 2 ESCC 3401 - Table 2 Table 2 Table 2 Table 2 Table 2	- R _{CL} R _M - - R _{CL} ΔR _{CL} R _I I _{VPL} R _M	Para. 4.3.4 Table 2 Table 2 - - Para. 4.3.4 Table 2 - 3 Table 2 Table 2 Table 2	mΩ (2)	
Permanence of Marking	Para. 9.19	-	-	-	-		
Mating and Unmating Forces	Para. 9.20	Mating and Unmating Forces	ESCC 3401	-	Para. 4.3.4		

ESCC Generic Spec. No. 3401		Measurements and Inspections		Symbol	Limits		Unit
Environmental and Endurance Tests (1)	Test Method and Conditions	Identification	Conditions		Min	Max	
High Temperature Storage	Para. 9.21	Initial Measurements					
		Visual Examination	ESCC 3401	-	-		
		Insulation Resistance	Table 2	R _i	Table 2		
		Voltage Proof Leakage Current	Table 2	I _{VPL}	Table 2		
		Low Level Contact Resistance	Table 2	R _{CL}	Table 2		
		Rated Current Contact Resistance	Table 2	R _{CR}	Table 2		
		Mated Shell Conductivity	Table 2	R _M	Table 2		
		Final Measurements					
		Visual Examination	ESCC 3401	-	-		
		Mating and Unmating Forces	-	-	Para. 4.3.4		
		Low Level Contact Resistance	Table 2	R _{CL}	Table 2		
		Low Level Contact Resistance Drift	Table 2	ΔR _{CL}	- 3	mΩ (2)	
		Rated Current Contact Resistance	Table 2	R _{CR}	Table 2		
Insulation Resistance	Table 2	R _i	Table 2				
Voltage Proof Leakage Current	Table 2	I _{VPL}	Table 2				
Mated Shell Conductivity	Table 2	R _M	Table 2				
Contact Retention (in insert)	ESCC 3401	-	Para. 4.3.3				
Corrosion	Para. 9.22	Visual Examination	ESCC 3401	-	-	-	
Insert Retention (in Shell)	Para. 9.23, and Para. 4.3.5 herein	Visual Examination	ESCC 3401	-	ESCC 3401		
High Temperature Measurements	Para. 9.25	Initial Measurements					
		Visual Examination	ESCC 3401	-	-		
		Insulation Resistance	Table 2	R _i	Table 2		
		Voltage Proof Leakage Current	Table 2	I _{VPL}	Table 2		
		Low Level Contact Resistance	Table 2	R _{CL}	Table 2		
		Mated Shell Conductivity	Table 2	R _M	Table 2		
		Measurement at High Temperature					
Insulation Resistance	Table 2 (at T _{amb} = +125°C)	R _i	5	-	GΩ		
Solderability	Para. 9.31, and Para. 4.3.6 herein	-	-	-	-	-	

NOTES:

1. The tests in this Table refer to either Chart IV or V and shall be used as applicable.
2. Parameter Drift referred to the initial measurement prior to the test in question.
3. The final measurements from the previous test may be used as initial values.

APPENDIX A
AGREED DEVIATIONS FOR AXON' CABLE (F)

Items Affected	Description of Deviations
<p>Para. 4.2.4, Deviations from Qualification Tests – Chart IV</p>	<p>Qualification testing in accordance with ESCC No. 3401 Para. 8.1 and Chart IV may be replaced by Qualification Testing in accordance with ESCC Generic Specification No. 3409 Para. 7.1 and Chart F4A.</p> <p>In this case, the test vehicles contained in the Qualification Test Lot shall include connectors in accordance with this specification that are mated with applicable HDR cable assemblies in accordance with ESCC Detail Specification No. 3409/001. The selected test vehicles shall be agreed with the ESCC Executive.</p> <p>The following deviations shall apply to the testing requirements of ESCC No. 3409 Chart F4A and apply to the connectors specified herein:</p> <ul style="list-style-type: none"> • Para. 8.25, Shielding Effectiveness: <ul style="list-style-type: none"> ○ For Variants 01, 02, 03, 04: the requirements of ESCC 3409/001 shall apply. ○ For Variants 05, 06, 07, 08: Not applicable. • Para. 8.26, Cable Retention Force: is not applicable to the components specified herein. • Para. 8.27, Ageing: the requirements of Table 6 herein (i.e. High Temperature Storage) shall apply. • Para. 8.28, Mating Endurance: the requirements of Table 6 herein (i.e. Endurance) shall apply. • Para. 8.30, Bending: is not applicable to the components specified herein. • Para. 8.31, Vibration (Random and Sine): the requirements of Table 6 herein (i.e. Vibration) shall apply. • Para. 8.18.2, Temperature Cycling (200 cycles): the requirements of Table 6 herein (i.e. Rapid Change of Temperature) shall apply. • Para. 8.32, Thermal Stability and Skew: the requirements of ESCC 3409/001 shall apply. • Para. 8.21.4, Electrical Measurements at Room, High and Low Temperatures: the requirements of ESCC 3409/001 shall apply. • Para. 8.22, Radiographic Inspection: is not applicable to the components specified herein. • Para. 8.33, Destructive Physical Analysis: a solderability test shall be included, to be performed on all PCB terminations; the requirements of Table 6 herein (i.e. Solderability) shall apply. • Para. 8.34, Radiation: is not applicable to the components specified herein. • Para. 8.35, Permanence of Marking: shall be performed. • Para. 8.37, Crimp Contact Tensile Strength: is not applicable to the components specified herein.
<p>Para. 4.2.5, Deviations from Lot Acceptance Tests – Chart V</p>	<p>Lot Acceptance Testing in accordance with ESCC No. 3401 Para. 8.2 and Chart V may be replaced by Periodic Testing in accordance with ESCC Generic Specification No. 3409 Para. 7.2 and Chart F4B.</p> <p>In this case, the test vehicles used for testing shall include connectors in accordance with this specification that are mated with applicable HDR cable assemblies in accordance with ESCC Detail Specification No. 3409/001.</p> <p>(Continued...)</p>

Items Affected	Description of Deviations
Para. 4.2.5, Deviations from Lot Acceptance Tests – Chart V (Continued)	<p>The following deviations shall apply to the testing requirements of ESCC No. 3409 Chart F4B and apply to the connectors specified herein:</p> <ul style="list-style-type: none"> • Para. 8.25, Shielding Effectiveness: <ul style="list-style-type: none"> ○ For Variants 01, 02, 03, 04: the requirements of ESCC 3409/001 shall apply. ○ For Variants 05, 06, 07, 08: Not applicable. • Para. 8.31, Vibration (Random and Sine): the requirements of Table 6 herein (i.e. Vibration) shall apply. • Para. 8.18.2, Temperature Cycling (100 cycles): the requirements of Table 6 herein (i.e. Rapid Change of Temperature) shall apply. • Para. 8.32, Thermal Stability and Skew: the requirements of ESCC 3409/001 shall apply. • Para. 8.21.4, Electrical Measurements at Room, High and Low Temperatures: the requirements of ESCC 3409/001 shall apply. <p>Para. 8.22, Radiographic Inspection: is not applicable to the components specified herein.</p>