



**CONNECTOR SAVERS AND ACCESSORIES, ELECTRICAL,
RECTANGULAR, MICROMINIATURE, HIGH DATA RATE**

BASED ON TYPES AXOMACH

ESCC Detail Specification No. 3401/090

Issue 4	December 2023
---------	---------------



LEGAL DISCLAIMER AND COPYRIGHT

European Space Agency, Copyright © 2023. All rights reserved.

The European Space Agency disclaims any liability or responsibility, to any person or entity, with respect to any loss or damage caused, or alleged to be caused, directly or indirectly by the use and application of this ESCC publication.

This publication, without the prior permission of the European Space Agency and provided that it is not used for a commercial purpose, may be:

- copied in whole, in any medium, without alteration or modification.
- copied in part, in any medium, provided that the ESCC document identification, comprising the ESCC symbol, document number and document issue, is removed.

DOCUMENTATION CHANGE NOTICE

(Refer to <https://escies.org> for ESCC DCR content)

DCR No.	CHANGE DESCRIPTION
1598	Specification updated to incorporate changes per DCR.

TABLE OF CONTENTS

1	GENERAL	5
1.1	SCOPE	5
1.2	COMPONENT TYPE VARIANTS AND RANGE OF COMPONENTS	5
1.3	MAXIMUM RATINGS	5
1.4	PARAMETER DERATING INFORMATION	5
1.5	PHYSICAL DIMENSIONS	5
2	APPLICABLE DOCUMENTS	15
3	TERMS, DEFINITIONS, ABBREVIATIONS, SYMBOLS AND UNITS	15
4	REQUIREMENTS	15
4.1	GENERAL	15
4.2	DEVIATIONS FROM THE GENERIC SPECIFICATION	16
4.2.1	Deviations from Special In-Process Controls	16
4.2.2	Deviations from Final Production Tests - Chart II(b)	16
4.2.3	Deviations from Burn-in and Electrical Measurements - Chart III	16
4.2.4	Deviations from Qualification Tests – Chart IV	16
4.2.5	Deviations from Lot Acceptance Tests – Chart V	17
4.3	MECHANICAL REQUIREMENTS	17
4.3.1	Dimension Check	17
4.3.2	Weight	17
4.3.3	Contact Capability	17
4.3.4	Contact Retention (in Insert)	17
4.3.5	Mating and Unmating Forces (Variants 01, 02, 03, 07 only)	17
4.3.6	Insert Retention (in Shell) (Variants 01, 02, 03, 07 only)	17
4.3.7	Engagement and Separation Forces	18
4.4	MATERIALS AND FINISHES	18
4.5	MARKING	18
4.5.1	General	18
4.5.2	The ESCC Component Number	18
4.6	ELECTRICAL MEASUREMENTS AT ROOM TEMPERATURE (VARIANTS 01, 02, 03 ONLY)	19
4.7	ENVIRONMENTAL AND ENDURANCE TESTS (CHARTS IV AND V OF ESCC GENERIC SPECIFICATION NO. 3401)	20
	APPENDIX A	24

1 GENERAL

1.1 SCOPE

This specification details the ratings, physical and electrical characteristics, test and inspection data for Electrical, Rectangular, Microminiature, High Data Rate Connector Savers, and Accessories, based on type AxoMach.

It shall be read in conjunction with:

- ESCC Generic Specification No. [3401](#), Connectors, Electrical, Rectangular and Circular.
- ESCC Detail Specification No. [3401/089](#), Connectors, Electrical, Rectangular, Microminiature, High Data Rate (Female Coaxial Contacts), based on type AxoMach and SpaceFibre.
- ESCC Detail Specification No. [3409/001](#), High Data Rate Cable Assembly with Microminiature Rectangular, Coaxial Connectors, based on types AxoMach and SpaceFibre.

the requirements of which are supplemented herein.

1.2 COMPONENT TYPE VARIANTS AND RANGE OF COMPONENTS

The different physical configurations of the basic type connectors specified herein are scheduled in Table 1(a).

1.3 MAXIMUM RATINGS

The maximum ratings, which shall not be exceeded at any time during use or storage, applicable to the connectors specified herein, are given in Table 1(b).

1.4 PARAMETER DERATING INFORMATION

The derating information applicable to the connectors specified herein is shown in Figure 1.

1.5 PHYSICAL DIMENSIONS

The physical dimensions and characteristics of the connectors specified herein are shown in Figure 2.

TABLE 1(a) – COMPONENT TYPE VARIANTS AND RANGE OF COMPONENTS

Variant Number	Description	Physical Configuration	Weight Max (g)
01	Connector Saver, AxoMach HDR, 1 Way	See Figure 2(a)	5
02	Connector Saver, AxoMach HDR, 2 Way	See Figure 2(b)	7
03	Connector Saver, AxoMach HDR, 4 Way	See Figure 2(c)	12
04	Blanking Plug, AxoMach HDR, 1 Way	See Figure 2(d)	3
05	Blanking Plug, AxoMach HDR, 2 Way	See Figure 2(e)	4
06	Blanking Plug, AxoMach HDR, 4 Way	See Figure 2(f)	5.5
07	Connector Saver, SpaceFibre HDR	See Figure 2(g)	4.9
08	Blanking Plug, SpaceFibre HDR	See Figure 2(h)	3.5

TABLE 1(b) - MAXIMUM RATINGS

Characteristics	Symbols	Maximum Ratings	Units	Remarks
Maximum Operating Data Rate	DR_{max}	10	Gb/s	Not applicable to Variants 04, 05, 06, 08.
Operating Frequency Range	f_R	≤ 10	GHz	Not applicable to Variants 04, 05, 06, 08.
Working Voltage	U_R	150	Vrms	At sea level. Note 1. See Figure 1(a). Not applicable to Variants 04, 05, 06, 08.
Rated Current	I_R	1	A	Each contact. Not applicable to Variants 04, 05, 06, 08.
Operating Temperature Range	T_{op}	-55 to +125	°C	T_{amb}
Storage Temperature Range	T_{stg}	-55 to +125	°C	

NOTES:

- Between contacts, and contacts and shell.

FIGURE 1 - PARAMETER DERATING INFORMATION

FIGURE 1(a) - WORKING VOLTAGE VERSUS ALTITUDE (NOTE 1)

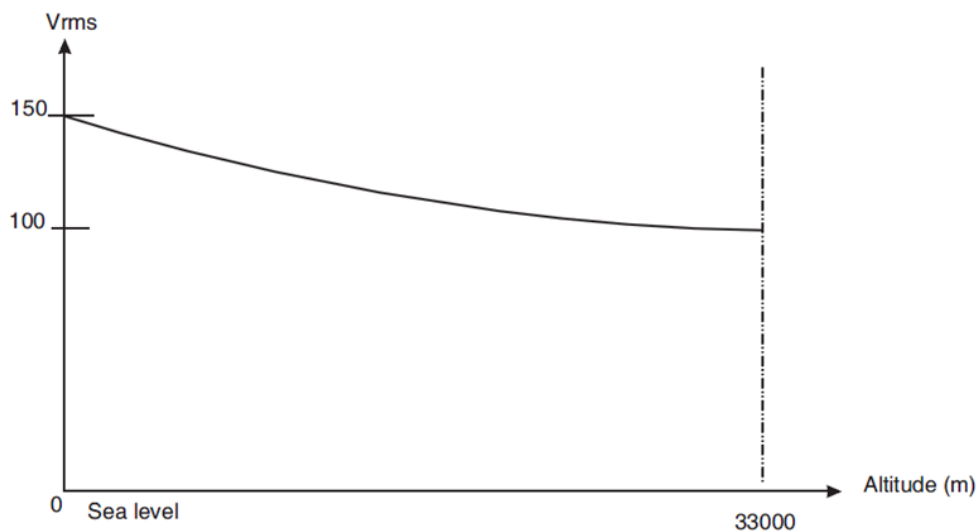

NOTES:

- Not applicable to Variants 04, 05, 06, 08.

FIGURE 2 - PHYSICAL DIMENSIONS

FIGURE 2(a) – VARIANT 01 - CONNECTOR SAVER, AXOMACH HDR, 1 WAY

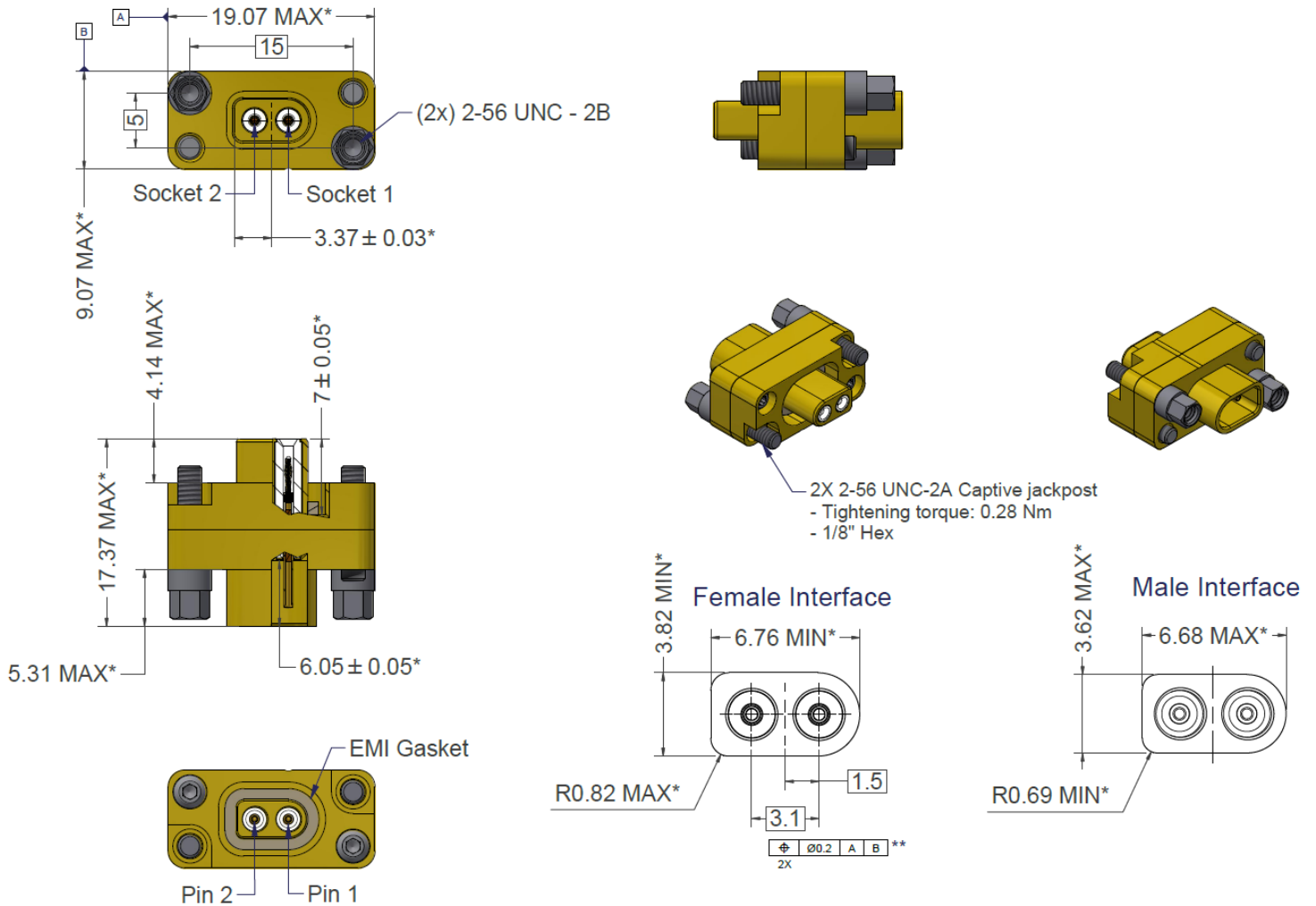

NOTES:

1. All dimensions are in mm.
2. Dimensions with an asterisk (*) shall be checked after assembly of the connector.
3. For connector interface dimensions, see also Figure 2(h).
4. Mating torque: 0.28N.m (+10 -0)%.
5. Contact identification: contact (pin & socket) Nos. 1 and 2 are indicated by the physical configuration. In addition, contact No. 1 is indicated by an index mark on the shell above pin/socket 1 (as shown above).

FIGURE 2(b) – VARIANT 02 - CONNECTOR SAVER, AXOMACH HDR, 2 WAY

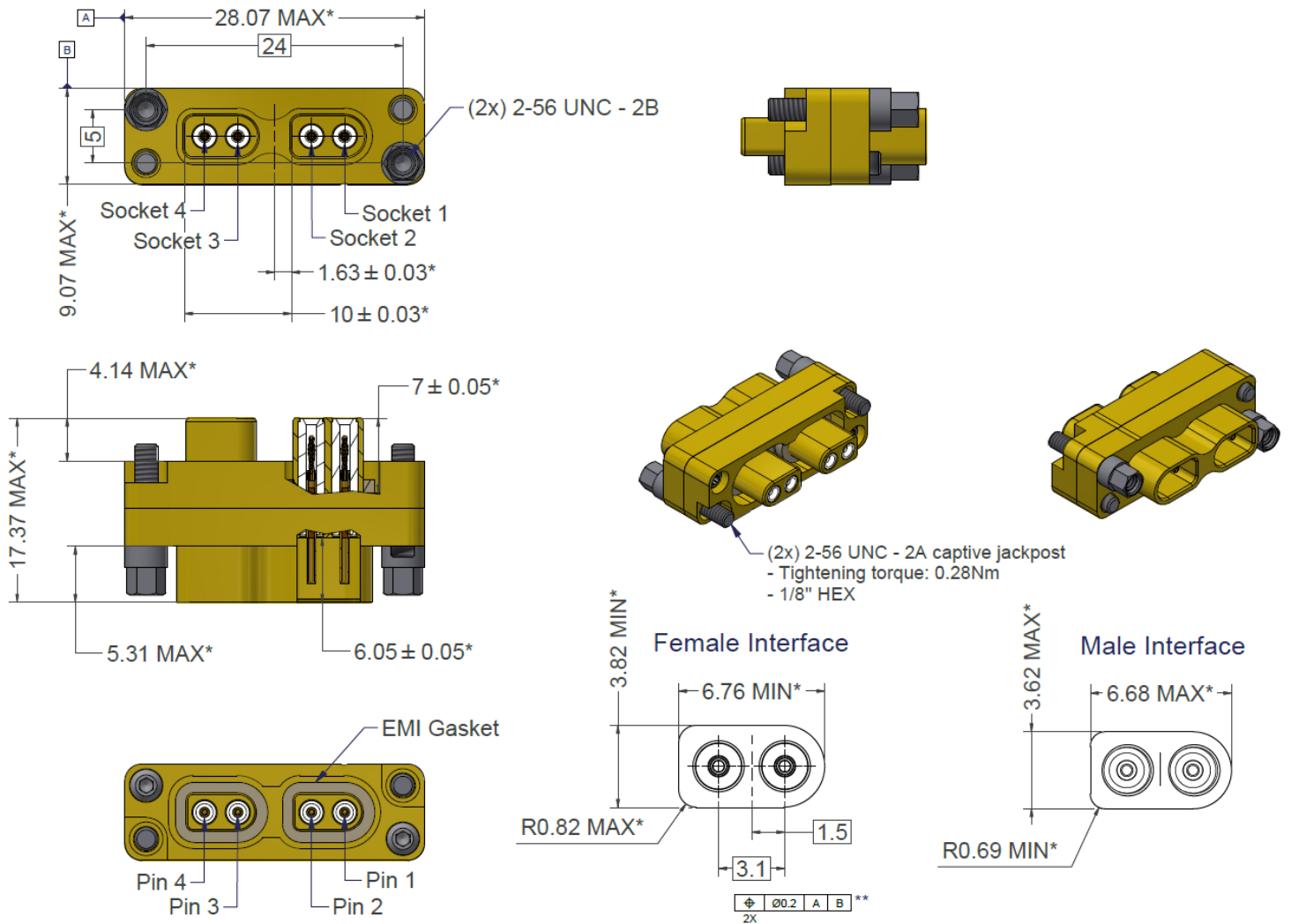

NOTES:

1. All dimensions are in mm.
2. Dimensions with an asterisk (*) shall be checked after assembly of the connector.
3. For connector interface dimensions, see also Figure 2(h).
4. Mating torque: 0.28N.m (+10 -0)%.
5. Contact identification: contact (pin & socket) Nos. 1 to 4 are indicated by the physical configuration (as shown above). In addition, contact No. 1 is indicated by an index mark on the shell above pin/socket 1 (as shown above).

FIGURE 2(c) – VARIANT 03 - CONNECTOR SAVER, AXOMACH HDR, 4 WAY

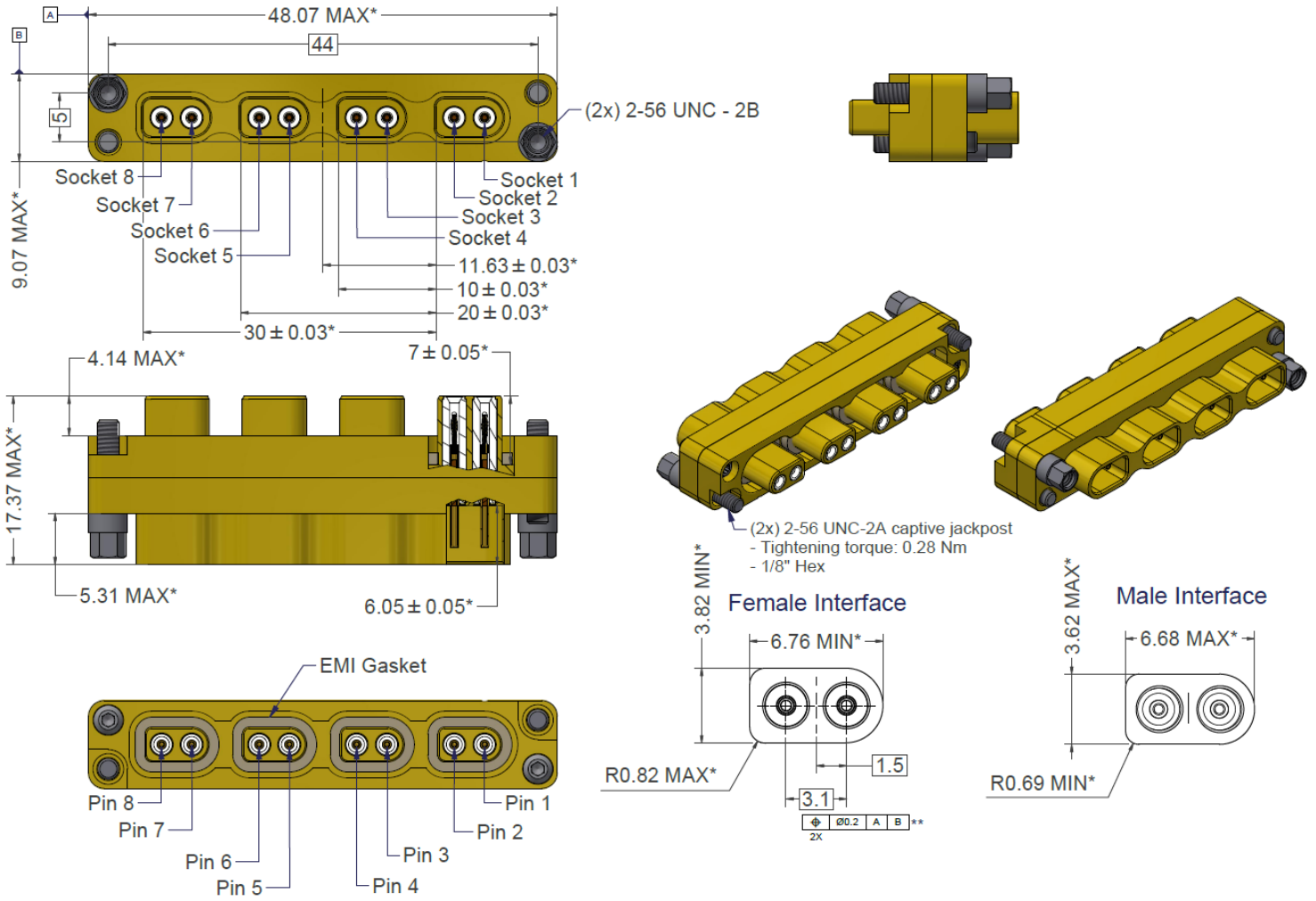

NOTES:

1. All dimensions are in mm.
2. Dimensions with an asterisk (*) shall be checked after assembly of the connector.
3. For connector interface dimensions, see also Figure 2(h).
4. Mating torque: 0.28N.m (+10 -0)%.
5. Contact identification: contact (pin & socket) Nos. 1 to 8 are indicated by the physical configuration (as shown above). In addition, contact No. 1 is indicated by an index mark on the shell above pin/socket 1 (as shown above).

FIGURE 2(d) – VARIANT 04 - BLANKING PLUG, AXOMACH HDR, 1 WAY

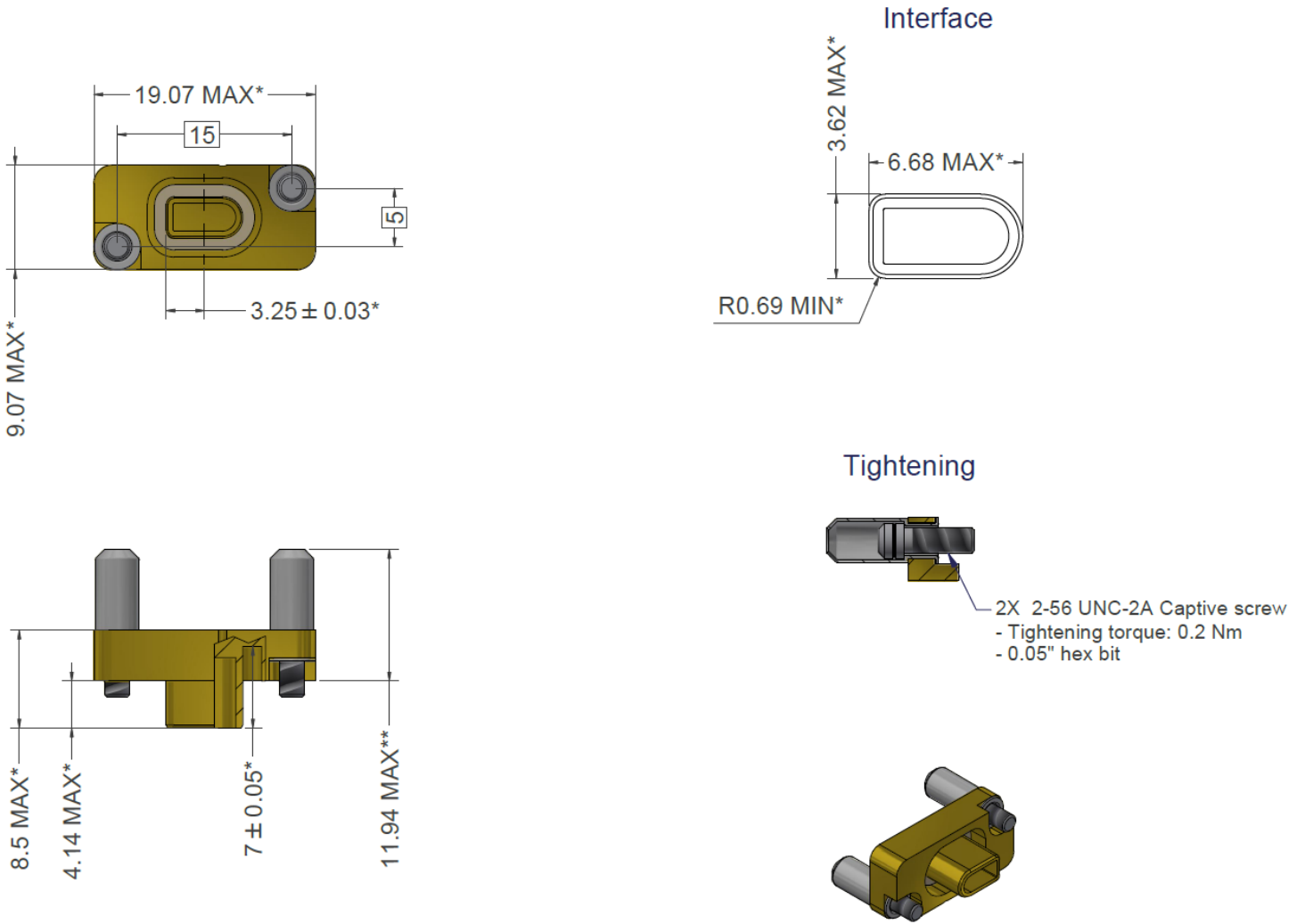

NOTES:

1. All dimensions are in mm.
2. Dimensions with an asterisk (*) shall be checked after assembly of the connector.
3. Mating torque: 0.2N.m (+5 -0)%.

FIGURE 2(e) – VARIANT 05 - BLANKING PLUG, AXOMACH HDR, 2 WAY

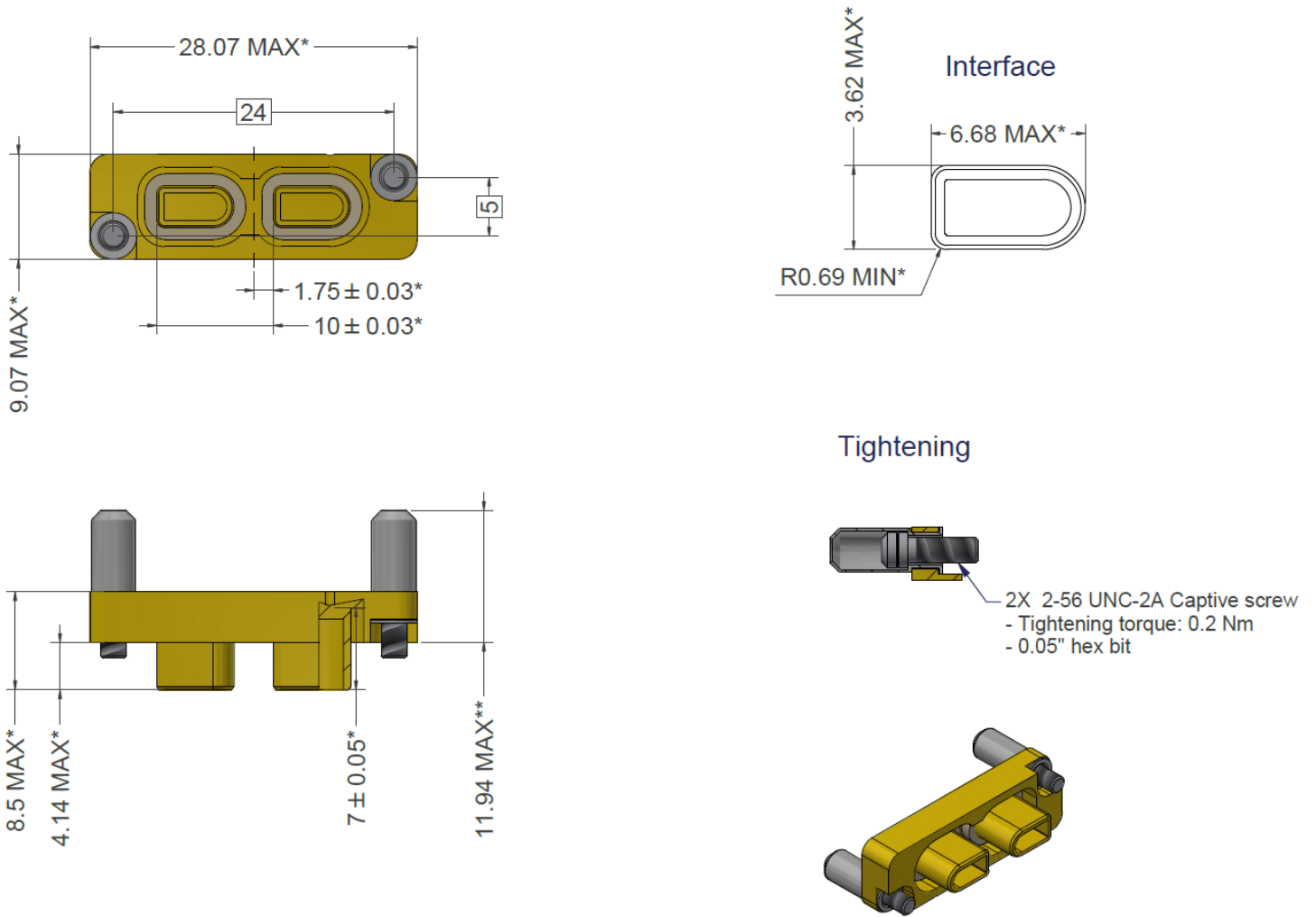

NOTES:

1. All dimensions are in mm.
2. Dimensions with an asterisk (*) shall be checked after assembly of the connector.
3. Mating torque: 0.2N.m (+5 -0)%.

FIGURE 2(f) – VARIANT 06 - BLANKING PLUG, AXOMACH HDR, 4 WAY

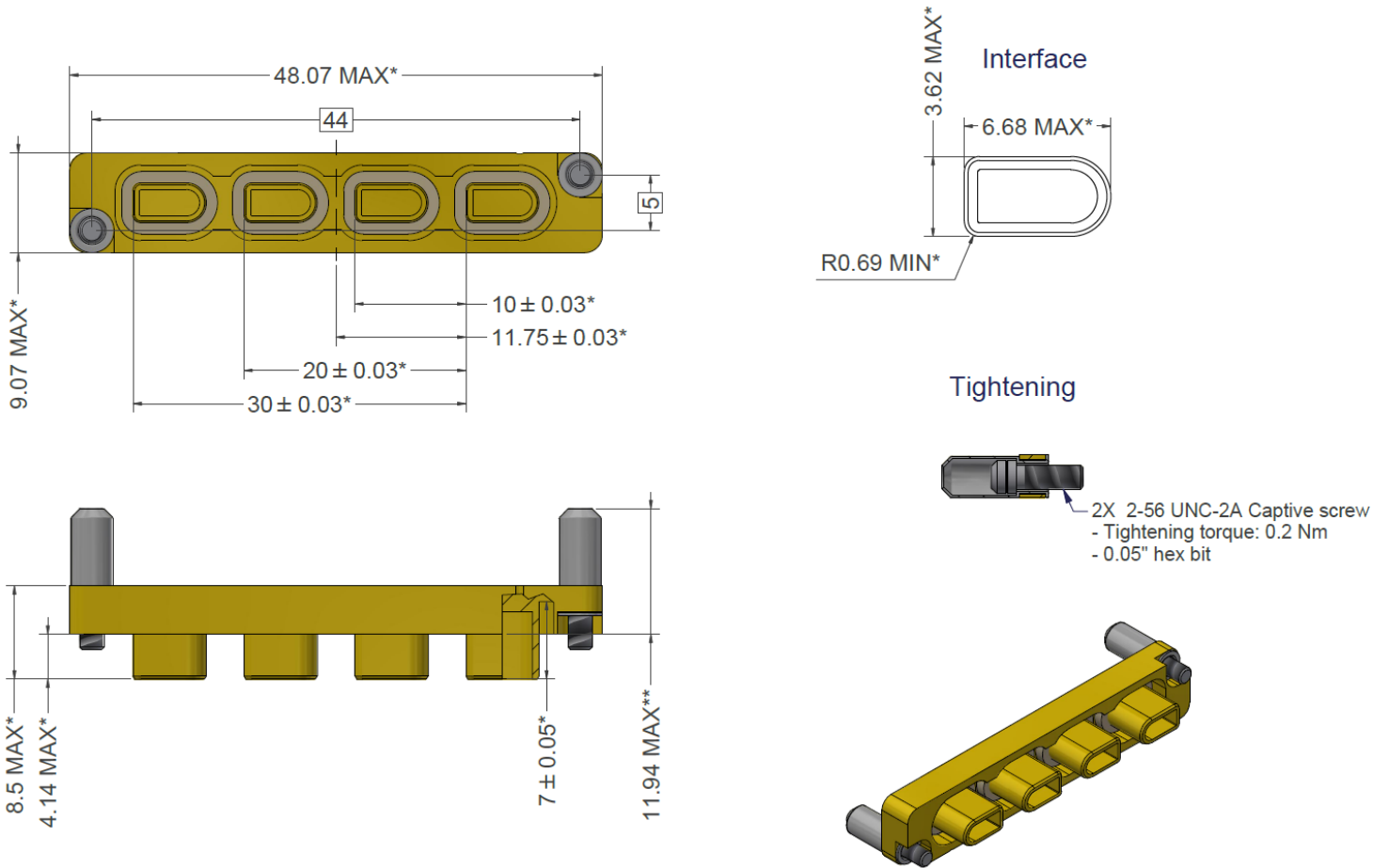

NOTES:

1. All dimensions are in mm.
2. Dimensions with an asterisk (*) shall be checked after assembly of the connector.
3. Mating torque: 0.2N.m (+5 -0)%.

FIGURE 2(g) – VARIANT 07 - CONNECTOR SAVER, SPACEFIBRE HDR

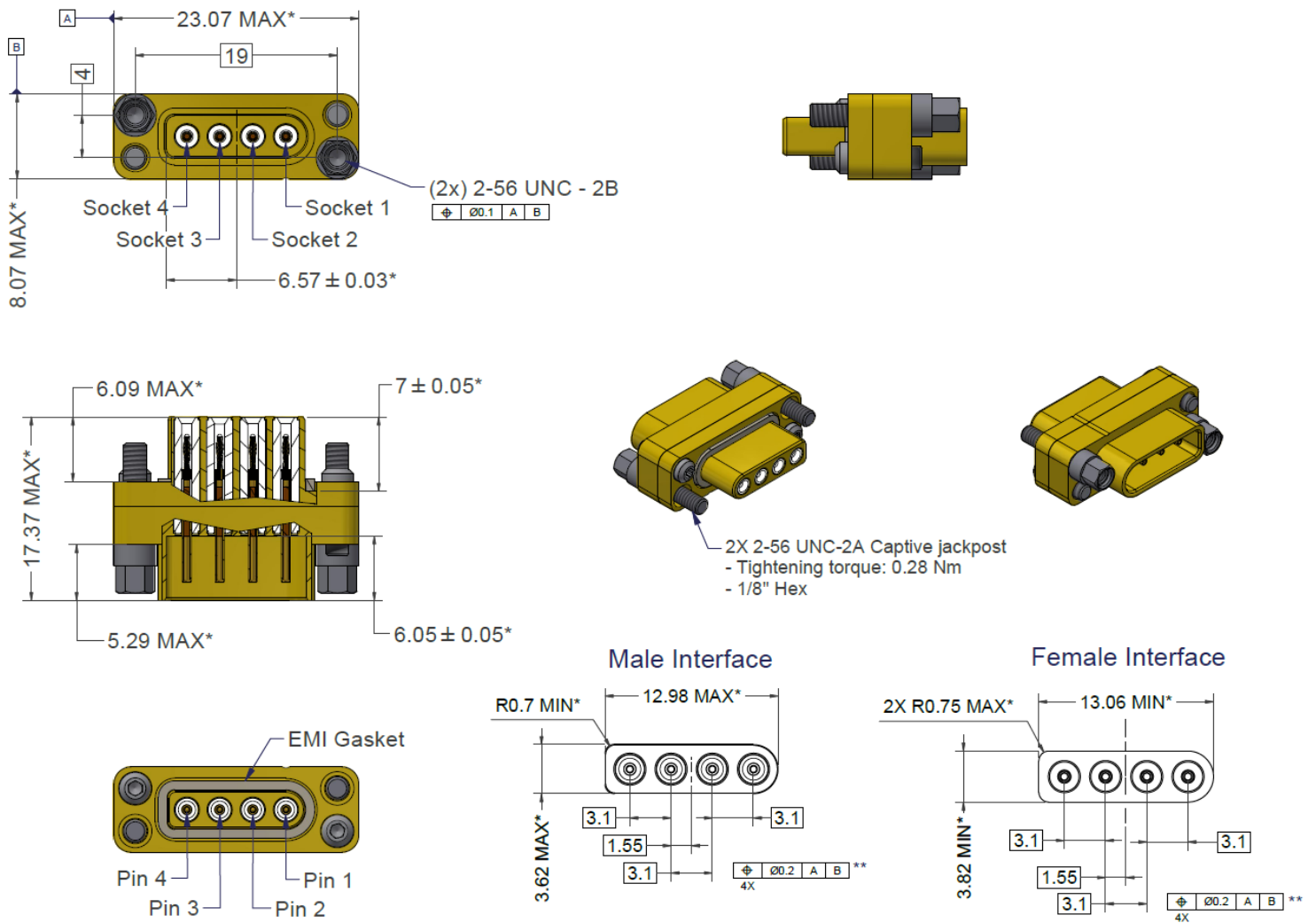

NOTES:

1. All dimensions are in mm.
2. Dimensions with an asterisk (*) shall be checked after assembly of the connector.
3. For connector interface dimensions, see also Figure 2(h).
4. Mating torque: 0.28N.m (+10 -0)%.
5. Contact identification: contact (pin & socket) Nos. 1 to 4 are indicated by the physical configuration. In addition, contact No. 1 is indicated by an index mark on the shell above pin/socket 1 (as shown above).

FIGURE 2(h) – VARIANT 08 - BLANKING PLUG, SPACEFIBRE HDR

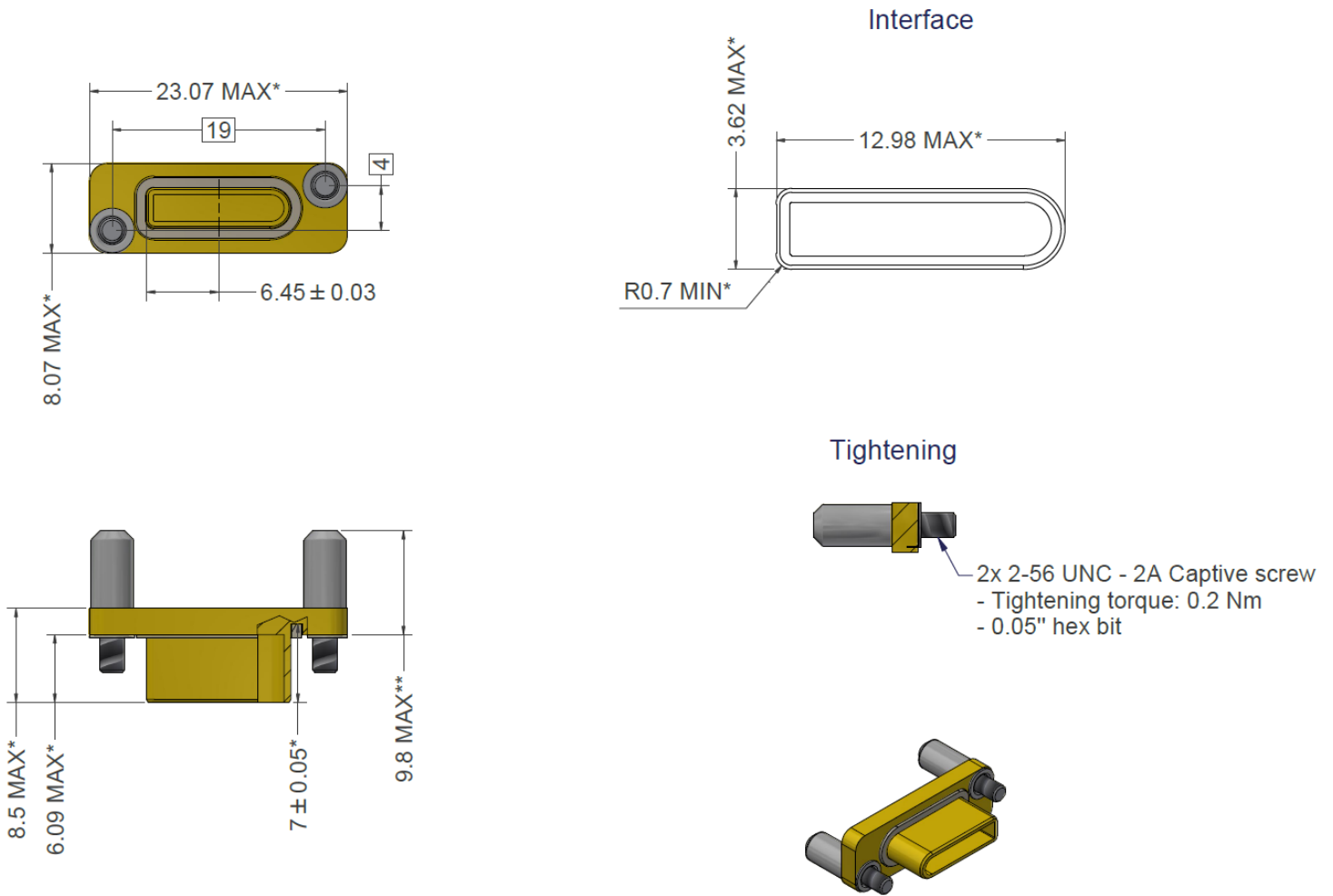

NOTES:

1. All dimensions are in mm.
2. Dimensions with an asterisk (*) shall be checked after assembly of the connector.
3. Mating torque: 0.2N.m (+5 -0)%.

FIGURE 2(h) - INTERFACE DIMENSIONS – VARIANTS 01, 02, 03, 07

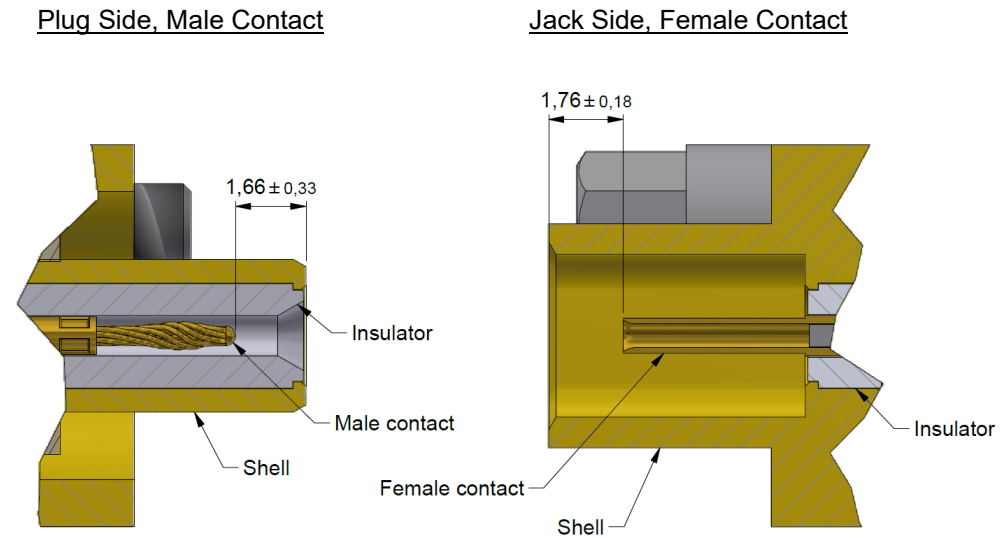

NOTES:

1. All dimensions are in mm.

2 APPLICABLE DOCUMENTS

The following documents form part of this specification and shall be read in conjunction with it:

- (a) ESCC Generic Specification No. [3401](#), Connectors, Electrical, Circular and Rectangular.
- (b) ESCC Detail Specification No. [3401/089](#), Connectors, Electrical, Rectangular, Microminiature, High Data Rate (Female Coaxial Contacts), based on type AxoMach and SpaceFibre.
- (c) ESCC Detail Specification No. [3409/001](#), High Data Rate Cable Assembly with Microminiature, Rectangular, Coaxial Connectors, based on types AxoMach and SpaceFibre.

3 TERMS, DEFINITIONS, ABBREVIATIONS, SYMBOLS AND UNITS

For the purpose of this specification, the terms, definitions, abbreviations, symbols and units specified in ESCC Basic Specification No. [21300](#) shall apply.

4 REQUIREMENTS

4.1 GENERAL

The complete requirements for procurement of the connectors specified herein are stated in this specification and ESCC Generic Specification No. [3401](#). Deviations from the Generic Specification, applicable to this specification only, are listed in Para. 4.2.

Deviations from the applicable Generic Specification and this Detail Specification, formally agreed with specific Manufacturers on the basis that the alternative requirements are equivalent to the ESCC requirements and do not affect the components' reliability, are listed in the appendices attached to this specification.

4.2 DEVIATIONS FROM THE GENERIC SPECIFICATION

4.2.1 Deviations from Special In-Process Controls

- (a) Crimping Capability:
- For Variants 01, 02, 03, 07: The minimum tensile strength shall be 30N.
 - For Variants 04, 05, 06, 08: Not applicable.
- (b) Solderability: Not applicable.

4.2.2 Deviations from Final Production Tests - Chart II(b)

- (a) Para. 9.4, Contact Capability: For Variants 04, 05, 06, 08: Not applicable.
- (b) Para. 9.6, Dimension Check (Contacts): For Variants 04, 05, 06, 08: Not applicable.
- (c) Para. 9.8, Installation of Contacts into Insert: For Variants 04, 05, 06, 08: Not applicable.
- (d) Para. 9.1.4, Electrical Measurements at Room Temperature: For Variants 04, 05, 06, 08: Not applicable.
- (e) Para. 9.9, Seal Test: Not applicable
- (f) Para. 9.5, Magnetism Level: Not applicable.

4.2.3 Deviations from Burn-in and Electrical Measurements - Chart III

None (Chart III is not applicable).

4.2.4 Deviations from Qualification Tests – Chart IV

- (a) Para. 9.9, Seal Test: Not applicable.
- (b) Para. 9.10, Wiring: Not applicable.
- (c) Para. 9.11, Vibration: Measurements and inspections shall be performed in accordance with Table 6 herein.
- (d) Para. 9.12, Shock or Bump: Measurements and inspections shall be performed in accordance with Table 6 herein.
- (e) Para. 9.13, Climatic Sequence: Measurements and inspections shall be performed in accordance with Table 6 herein.
- (f) Para. 9.15, Joint Strength: Not applicable.
- (g) Para. 9.16, Rapid Change of Temperature: Measurements and inspections shall be performed in accordance with Table 6 herein.
- (h) Para. 9.17, Contact Retention (in Insert): For Variants 04, 05, 06, 08: Not applicable.
- (i) Para. 9.18, Endurance: For Variants 04, 05, 06, 08: Not applicable.
- (j) Para. 9.20, Mating and Unmating Forces: For Variants 04, 05, 06, 08: Not applicable.
- (k) Para. 9.21, High Temperature Storage:
- For Variants 01, 02, 03, 07: Measurements and inspections shall be performed in accordance with Table 6 herein.
 - For Variants 04, 05, 06, 08: Not applicable.
- (l) Para. 9.23, Insert Retention (in Shell): For Variants 04, 05, 06, 08: Not applicable.
- (m) Para. 9.24, Jackscrew Retention: Not applicable.
- (n) Para. 9.25, High Temperature Measurement:
- For Variants 01, 02, 03, 07: Measurements and inspections shall be performed in accordance with Table 6 herein.
 - For Variants 04, 05, 06, 08: Not applicable.
- (o) Para. 9.26, Overload: Not applicable.
- (p) Para. 9.27, Maintenance Aging: Not applicable.
- (q) Para. 9.28, Engagement and Separation Forces: For Variants 04, 05, 06, 08: Not applicable.
- (r) Para. 9.29, Oversize Pin Exclusion: Not applicable.
- (s) Para. 9.30, Probe Damage: Not applicable.
- (t) Para. 9.31, Solderability: Not applicable.

4.2.5 Deviations from Lot Acceptance Tests – Chart V

- (a) Para. 9.9, Seal Test: Not applicable.
- (b) Para. 9.10, Wiring: Not applicable.
- (c) Para. 9.13, Climatic Sequence:
 - For Variants 01, 02, 03, 07: Measurements and inspections shall be performed in accordance with Table 6 herein.
 - For Variants 04, 05, 06, 08: Not applicable.
- (d) Para. 9.15, Joint Strength: Not applicable.
- (e) Para. 9.16, Rapid Change of Temperature:
 - For Variants 01, 02, 03, 07: Measurements and inspections shall be performed in accordance with Table 6 herein.
 - For Variants 04, 05, 06, 08: Not applicable.
- (f) Para. 9.17, Contact Retention (in Insert): For Variants 04, 05, 06, 08: Not applicable.
- (g) Para. 9.18, Endurance: For Variants 04, 05, 06, 08: Not applicable.
- (h) Para. 9.27, Maintenance Aging: Not applicable.
- (i) Para. 9.28, Engagement and Separation Forces: For Variants 04, 05, 06, 08: Not applicable.
- (j) Para. 9.29, Oversize Pin Exclusion: Not applicable.
- (k) Para. 9.30, Probe Damage: Not applicable.

4.3 MECHANICAL REQUIREMENTS

4.3.1 Dimension Check

See Figure 2.

4.3.2 Weight

See Table 1(a).

4.3.3 Contact Capability

Only applicable to the male side of Variants 01, 02, 03, 07:

	Pick-up Test	Drop Test
Weight (g)	14 ±1	170 ±1
Test Sleeve Inner Diameter (mm)	0.582 to 0.587	0.559 to 0.564
Insertion Depth (mm)	1.5 ±0.05	1.5 ±0.05

4.3.4 Contact Retention (in Insert)

Only applicable to the female side of Variants 01, 02, 03, 07.

Applied force: 14.8N.

4.3.5 Mating and Unmating Forces (Variants 01, 02, 03, 07 only)

Variant Number	Mating Force (N)	Unmating Force (N)	
	Max	Min	Max
01	5.6	0.4	5.6
02, 07	11.2	0.8	11.2
03	22.4	1.6	22.4

4.3.6 Insert Retention (in Shell) (Variants 01, 02, 03, 07 only)

Maximum load: 4N.

4.3.7 Engagement and Separation Forces

Only applicable to the male side of Variants 01, 02, 03, 07:

	Minimum Diameter Test Sleeve Test	Maximum Diameter Test Sleeve Test
Engagement Force (N)	1.667 maximum	-
Separation Force (N)	-	0.14 minimum
Test Sleeve Inner Diameter (mm)	0.559 to 0.564	0.582 to 0.587
Insertion Depth (mm)	1.4 ±0.05	1.4 ±0.05

4.4 MATERIALS AND FINISHES

The materials and finishes shall be as specified herein. Where a definite material is not specified, a material which will enable the components specified herein to meet the performance requirements of this specification shall be used. Acceptance or approval of any constituent material does not guarantee acceptance of the finished product.

- (a) Body Shell:
 - Variants 01, 02, 03, 07: Aluminium alloy, gold plated 1µm minimum over nickel underplate 3µm minimum.
 - Variants 04, 05, 06, 08: Aluminium alloy, gold plated 2.54µm minimum over nickel underplate 25µm minimum.
- (b) Centre Contact (Variants 01, 02, 03, 07): Copper alloy, gold plated 1.27µm minimum over nickel underplate 1.27µm minimum.
 Note: measurements of plating thickness shall be made at 1.5mm from the engagement end.
- (c) Male plug connector front face, and connector to backshell interface EMI seals: Conductive silicone-base rubber.
- (d) Insert (insulator) (Variants 01, 02, 03, 07): PTFE.
- (e) Locking devices: Passivated stainless steel.

4.5 MARKING

4.5.1 General

The marking shall be in accordance with the requirements of ESCC Basic Specification No. 21700 and as follows.

The information to be marked on the component or its primary package shall be:

- (a) The ESCC qualified components symbol (for ESCC qualified components only).
- (b) The ESCC Component Number.
- (c) Traceability Information.

4.5.2 The ESCC Component Number

The ESCC Component Number shall be constituted as follows:

Example: 340109001B

- Detail Specification Reference: 3401090
- Component Type Variant Number (see Table 1(a)): 01 (as required)
- Testing Level: B

4.6 **ELECTRICAL MEASUREMENTS AT ROOM TEMPERATURE (VARIANTS 01, 02, 03 ONLY)**
 The parameters to be measured in respect of electrical characteristics are scheduled in Table 2. Unless otherwise specified, the measurements shall be performed at $T_{amb} = +22 \pm 3^{\circ}C$.

**TABLE 2 - ELECTRICAL MEASUREMENTS AT ROOM TEMPERATURE
 (VARIANTS 01, 02, 03, 07 ONLY)**

Characteristics	Symbols	Test Method and Conditions	Limits		Units
			Min	Max	
Insulation Resistance	R_i	ESCC No. 3401 V = 500Vdc	5	-	GΩ
Voltage Proof Leakage Current	I_{VPL}	V = 600Vrms	-	2	mA
Contact Resistance (Low Level Current)	R_{CL}	ESCC No. 3401	-	12	mΩ
Contact Resistance (Rated Current)	R_{CR}	ESCC No. 3401	-	10	mΩ
Mated Shell Conductivity	R_M	ESCC No. 3401	-	5	mΩ

TABLES 3, 4, 5

Not applicable

4.7 ENVIRONMENTAL AND ENDURANCE TESTS (CHARTS IV AND V OF ESCC GENERIC SPECIFICATION No. 3401)

The parameters to be measured and inspections to be performed on completion of environmental and endurance testing shall be those specified in Table 6.

Unless otherwise specified, the measurements shall be performed at $T_{amb} = +22 \pm 3^{\circ}C$

Unless otherwise specified, test methods and test conditions shall be as per the corresponding test defined in Table 2

TABLE 6 - MEASUREMENTS AND INSPECTIONS ON COMPLETION OF ENVIRONMENTAL AND ENDURANCE TESTING

ESCC Generic Spec. No. 3401		Measurements and Inspections (2)		Symbol	Limits		Unit
Environmental and Endurance Tests (1)	Test Method and Conditions	Identification	Conditions		Min	Max	
Vibration	Para. 9.11	Initial Measurements					
		Coupling Screws Unlocking Torque	ESCC 3401	Tqe	Record Values		
		Insulation Resistance	Table 2	R _i	Table 2		
		Voltage Proof Leakage Current	Table 2	I _{VPL}	Table 2		
		Low Level Contact Resistance	Table 2	R _{CL}	Table 2		
		Mated Shell Conductivity	Table 2	R _M	Table 2		
		Measurements during Vibration					
		Monitor Contact Disturbance	ESCC 3401	-	-	1	μs
		Final Measurements					
		Coupling Screws Unlocking Torque Drift	ESCC 3401	ΔTqe/Tqe	-25	+25	% (3)
		Insulation Resistance	Table 2	R _i	Table 2		
		Voltage Proof Leakage Current	Table 2	I _{VPL}	Table 2		
		Voltage Proof Leakage Current Drift	Table 2	ΔI _{VPL}	-	+25	% (3)
		Low Level Contact Resistance	Table 2	R _{CL}	Table 2		
		Low Level Contact Resistance Drift	Table 2	ΔR _{CL}	-	+25	% (3)
Mated Shell Conductivity	Table 2	R _M	Table 2				
Mated Shell Conductivity Drift	Table 2	ΔR _M	-	+25	% (3)		
Visual Examination	ESCC 3401	-	-	-			

ESCC Generic Spec. No. 3401		Measurements and Inspections (2)		Symbol	Limits		Unit
Environmental and Endurance Tests (1)	Test Method and Conditions	Identification	Conditions		Min	Max	
Shock or Bump	Para. 9.12	Initial Measurements (4)					
		Coupling Screws Unlocking Torque	ESCC 3401	Tqe	Record Values		
		Insulation Resistance	Table 2	R _i	Table 2		
		Voltage Proof Leakage Current	Table 2	I _{VPL}	Table 2		
		Low Level Contact Resistance	Table 2	R _{CL}	Table 2		
		Mated Shell Conductivity	Table 2	R _M	Table 2		
		Measurements during Vibration					
		Monitor Contact Disturbance	ESCC 3401	-	-	1	μs
		Final Measurements					
		Coupling Screws Unlocking Torque Drift	ESCC 3401	ΔTqe/Tqe	-25	+25	% (3)
		Insulation Resistance	Table 2	R _i	Table 2		
		Voltage Proof Leakage Current	Table 2	I _{VPL}	Table 2		
		Voltage Proof Leakage Current Drift	Table 2	ΔI _{VPL}	-	+25	% (3)
Low Level Contact Resistance	Table 2	R _{CL}	Table 2				
Low Level Contact Resistance Drift	Table 2	ΔR _{CL}	-	+25	% (3)		
Mated Shell Conductivity	Table 2	R _M	Table 2				
Mated Shell Conductivity Drift	Table 2	ΔR _M	-	+25	% (3)		
Visual Examination	ESCC 3401	-	-	-			
Climatic Sequence (5)	Para. 9.13	Initial Measurements (4)					
		Insulation Resistance	Table 2	R _i	Table 2		
		Voltage Proof Leakage Current	Table 2	I _{VPL}	Table 2		
		Low Level Contact Resistance	Table 2	R _{CL}	Table 2		
		Mated Shell Conductivity	Table 2	R _M	Table 2		
		Dry Heat					
		Insulation Resistance	Table 2 (at T _{amb} = +125°C)	R _i	5	-	GΩ
		Low Air Pressure					
		Voltage Proof Leakage Current	100Vrms	I _{VPL}	-	1	mA
		Damp Heat					
		Insulation Resistance	Table 2	R _i	100	-	MΩ
Final Measurements							
External Visual Inspection	ESCC 3401	-	-				
Insulation Resistance	Table 2	R _i	Table 2				
Voltage Proof Leakage Current	Table 2	I _{VPL}	Table 2				
Plating Thickness	Para. 9.14	Plating Thickness	-	-	Para. 4.4		

ESCC Generic Spec. No. 3401		Measurements and Inspections (2)		Symbol	Limits		Unit
Environmental and Endurance Tests (1)	Test Method and Conditions	Identification	Conditions		Min	Max	
Rapid Change of Temperature (5)	Para. 9.16	Initial Measurements Visual Examination Insulation Resistance Voltage Proof Leakage Current Low Level Contact Resistance Mated Shell Conductivity Final Measurements Visual Examination Insulation Resistance Voltage Proof Leakage Current Low Level Contact Resistance Mated Shell Conductivity	ESCC 3401 Table 2 Table 2 Table 2 Table 2 ESCC 3401 Table 2 Table 2 Table 2 Table 2	- R _I I _{VPL} R _{CL} R _M - R _I I _{VPL} R _{CL} R _M	- Table 2 Table 2 Table 2 Table 2 - Table 2 Table 2 Table 2 Table 2		
Contact Retention (in Insert) (5)	Para. 9.17, and Para. 4.3.4 herein	Contact axial displacement	ESCC 3401	-	ESCC 3401		
Endurance (5)	Para. 9.18	Initial Measurements Mating and Unmating Forces Low Level Contact Resistance Mated Shell Conductivity Final Measurements Visual Examination Mating and Unmating Forces Low Level Contact Resistance Low Level Contact Resistance Drift Insulation Resistance Voltage Proof Leakage Current Mated Shell Conductivity	ESCC 3401 Table 2 Table 2 ESCC 3401 - Table 2 Table 2 Table 2 Table 2 Table 2 Table 2	- R _{CL} R _M - - R _{CL} ΔR _{CL} R _I I _{VPL} R _M	Para. 4.3.5 Table 2 Table 2 - - Para. 4.3.5 Table 2 - 3 Table 2 Table 2 Table 2	mΩ	
Permanence of Marking	Para. 9.19	-	-	-	-		
Mating and Unmating Forces (5)	Para. 9.20 and Para. 4.3.5 herein	Mating and Unmating Forces	ESCC 3401	-	Para. 4.3.5		

ESCC Generic Spec. No. 3401		Measurements and Inspections (2)		Symbol	Limits		Unit
Environmental and Endurance Tests (1)	Test Method and Conditions	Identification	Conditions		Min	Max	
High Temperature Storage (5)	Para. 9.21	Initial Measurements					
		Visual Examination	ESCC 3401	-	-		
		Insulation Resistance	Table 2	R _i	Table 2		
		Voltage Proof Leakage Current	Table 2	I _{VPL}	Table 2		
		Low Level Contact Resistance	Table 2	R _{CL}	Table 2		
		Rated Current Contact Resistance	Table 2	R _{CR}	Table 2		
		Mated Shell Conductivity	Table 2	R _M	Table 2		
		Final Measurements					
		Visual Examination	ESCC 3401	-	-		
		Mating and Unmating Forces	-	-	Para. 4.3.5		
		Low Level Contact Resistance	Table 2	R _{CL}	Table 2		
		Low Level Contact Resistance Drift	Table 2	ΔR _{CL}	- 3	mΩ	
		Rated Current Contact Resistance	Table 2	R _{CR}	Table 2		
		Insulation Resistance	Table 2	R _i	Table 2		
Voltage Proof Leakage Current	Table 2	I _{VPL}	Table 2				
Mated Shell Conductivity	Table 2	R _M	Table 2				
Contact Retention (in insert)	ESCC 3401	-	Para. 4.3.4				
Corrosion	Para. 9.22	Visual Examination	ESCC 3401	-	-	-	
Insert Retention (in Shell) (5)	Para. 9.23 and Para. 4.3.6 herein	Visual Examination	ESCC 3401	-	ESCC 3401		
High Temperature Measurements (5)	Para. 9.25	Initial Measurements					
		Visual Examination	ESCC 3401	-	-		
		Insulation Resistance	Table 2	R _i	Table 2		
		Voltage Proof Leakage Current	Table 2	I _{VPL}	Table 2		
		Low Level Contact Resistance	Table 2	R _{CL}	Table 2		
		Rated Current Contact Resistance	Table 2	R _{CR}	Table 2		
		Mated Shell Conductivity	Table 2	R _M	Table 2		
Measurement at High Temperature							
Insulation Resistance	Table 2 (at T _{amb} = +125°C)	R _i	5	-	GΩ		
Engagement and Separation Forces (5)	Para. 9.28 and Para. 4.3.7 herein	Engagement and Separation Forces	ESCC 3401	-	Para. 4.3.7		

NOTES:

1. The tests in this Table refer to either Chart IV or V and shall be used as applicable.
2. For Variants 04, 05, 06, 08, with the exception of Coupling Screws Unlocking Torque, mechanical and electrical measurements shall not be performed for all applicable tests.
3. Parameter Drift referred to the initial measurement prior to the test in question.
4. The final measurements from the previous test may be used as initial values.
5. Test applicable to Variants 01, 02, 03, 07 only.

APPENDIX A
AGREED DEVIATIONS FOR AXON' CABLE (F)

Items Affected	Description of Deviations
<p>Para. 4.2.4, Deviations from Qualification Tests – Chart IV</p>	<p>Qualification testing in accordance with ESCC No. 3401 Para. 8.1 and Chart IV may be replaced by Qualification Testing in accordance with ESCC Generic Specification No. 3409 Para. 7.1 and Chart F4A.</p> <p>In this case, the test vehicles contained in the Qualification Test Lot shall include connector savers and accessories in accordance with this specification that are mated with or fitted to applicable HDR cable assemblies/connectors in accordance with ESCC Detail Specification Nos. 3409/001 and 3401/089. The selected test vehicles shall be agreed with the ESCC Executive.</p> <p>The following deviations shall apply to the testing requirements of ESCC No. 3409 Chart F4A and apply to the components specified herein:</p> <ul style="list-style-type: none"> • Para. 8.25, Shielding Effectiveness: is not applicable to the components specified herein. • Para. 8.26, Cable Retention Force: is not applicable to the components specified herein. • Para. 8.27, Ageing: <ul style="list-style-type: none"> ○ For Variants 01, 02, 03, 07: the requirements of Table 6 herein (i.e. High Temperature Storage) shall apply. ○ For Variants 04, 05, 06, 08: Not applicable. • Para. 8.28, Mating Endurance: <ul style="list-style-type: none"> ○ For Variants 01, 02, 03, 07: the requirements of Table 6 herein (i.e. Endurance) shall apply. ○ For Variants 04, 05, 06, 08: Not applicable. • Para. 8.29.1, Contact Retention (in Insert): For Variants 04, 05, 06, 08: Not applicable. • Para. 8.30, Bending: is not applicable to the components specified herein. • Para. 8.31, Vibration (Random and Sine): the requirements of Table 6 herein (i.e. Vibration) shall apply. • Para. 8.18.2, Temperature Cycling (200 cycles): <ul style="list-style-type: none"> ○ For Variants 01, 02, 03, 07: the requirements of Table 6 herein (i.e. Rapid Change of Temperature) shall apply. ○ For Variants 04, 05, 06, 08: Not applicable. • Para. 8.32, Thermal Stability and Skew: <ul style="list-style-type: none"> ○ For Variants 01, 02, 03, 07: the requirements of ESCC 3409/001 shall apply. ○ For Variants 04, 05, 06, 08: Not applicable. • Para. 8.21.4, Electrical Measurements at Room, High and Low Temperatures: <ul style="list-style-type: none"> ○ For Variants 01, 02, 03, 07: the requirements of ESCC 3409/001 shall apply. ○ For Variants 04, 05, 06, 08: Not applicable. • Para. 8.22, Radiographic Inspection: is not applicable to the components specified herein. • Para. 8.34, Radiation: is not applicable to the components specified herein. • Para. 8.35, Permanence of Marking: shall be performed. • Para. 8.36, Mating and Unmating Forces: For Variants 04, 05, 06, 08: Not applicable. • Para. 8.29.2, Insert Retention (in Shell): For Variants 04, 05, 06, 08: Not applicable. • Para. 8.37, Crimp Contact Tensile Strength: is not applicable to the components specified herein.

Items Affected	Description of Deviations
<p>Para. 4.2.5, Deviations from Lot Acceptance Tests – Chart V</p>	<p>Lot Acceptance Testing in accordance with ESCC No. 3401 Para. 8.2 and Chart V may be replaced by Periodic Testing in accordance with ESCC Generic Specification No. 3409 Para. 7.2 and Chart F4B.</p> <p>In this case, the test vehicles shall include connector savers and accessories in accordance with this specification that are mated with or fitted to applicable HDR cable assemblies/connectors in accordance with ESCC Detail Specification Nos. 3409/001 and 3401/089.</p> <p>The following deviations shall apply to the testing requirements of ESCC No. 3409 Chart F4B that shall apply to the connectors specified herein:</p> <ul style="list-style-type: none"> • Para. 8.25, Shielding Effectiveness: is not applicable to the components specified herein. • Para. 8.31, Vibration (Random and Sine): the requirements of Table 6 herein (i.e. Vibration) shall apply. • Para. 8.18.2, Temperature Cycling (200 cycles): <ul style="list-style-type: none"> ○ For Variants 01, 02, 03, 07: the requirements of Table 6 herein (i.e. Rapid Change of Temperature) shall apply. ○ For Variants 04, 05, 06, 08: Not applicable. • Para. 8.32, Thermal Stability and Skew: <ul style="list-style-type: none"> ○ For Variants 01, 02, 03, 07: the requirements of ESCC 3409/001 shall apply. ○ For Variants 04, 05, 06, 08: Not applicable. • Para. 8.21.4, Electrical Measurements at Room, High and Low Temperatures: <ul style="list-style-type: none"> ○ For Variants 01, 02, 03, 07: the requirements of ESCC 3409/001 shall apply. ○ For Variants 04, 05, 06, 08: Not applicable. • Para. 8.22, Radiographic Inspection: is not applicable to the components specified herein.