



**HIGH DATA RATE CABLE ASSEMBLY WITH
MICROMINIATURE, RECTANGULAR,
COAXIAL CONNECTORS**

BASED ON TYPES AXOMACH AND SPACEFIBRE

ESCC Detail Specification No. 3409/001

Issue 6	December 2023
---------	---------------



LEGAL DISCLAIMER AND COPYRIGHT

European Space Agency, Copyright © 2023, All rights reserved.

The European Space Agency disclaims any liability or responsibility, to any person or entity, with respect to any loss or damage caused, or alleged to be caused, directly or indirectly by the use and application of this ESCC publication.

This publication, without the prior permission of the European Space Agency and provided that it is not used for a commercial purpose, may be:

- copied in whole, in any medium, without alteration or modification.
- copied in part, in any medium, provided that the ESCC document identification, comprising the ESCC symbol, document number and document issue, is removed.

DOCUMENTATION CHANGE NOTICE

(Refer to <https://escies.org> for ESCC DCR content)

DCR No.	CHANGE DESCRIPTION
1599	Specification updated to incorporate changes per DCR.

TABLE OF CONTENTS

1	GENERAL	6
1.1	SCOPE	6
1.2	APPLICABLE DOCUMENTS	6
1.3	TERMS, DEFINITIONS, ABBREVIATIONS, SYMBOLS AND UNITS	6
1.4	THE ESCC COMPONENT NUMBER AND COMPONENT TYPE VARIANTS	6
1.4.1	The ESCC Component Number	6
1.4.2	Range of Components	7
1.4.2.1	Cable Assembly Configuration	8
1.4.3	Manufacturer Specific Assembly Identification	10
1.5	MAXIMUM RATINGS	11
1.6	PHYSICAL DIMENSIONS	12
1.6.1	Cable Assembly Dimensions	12
1.6.2	Connectors	13
1.6.2.1	Connector Code 01 – AxoMach HDR, 1 Way, Male, In-line Plug (with 2 HDR cables)	13
1.6.2.2	Connector Code 02 - AxoMach HDR, 2 Way, Male, In-line Plug (with 4 HDR cables)	14
1.6.2.3	Connector Code 03 - AxoMach HDR, 4 Way, Male, In-line Plug (with 8 HDR cables)	15
1.6.2.4	Connector Code 04 - AxoMach HDR, 1 Way, Female, In-line Jack (with 2 HDR cables)	16
1.6.2.5	Connector Code 05 - AxoMach HDR, 2 Way, Female, In-line Jack (with 4 HDR cables)	17
1.6.2.6	Connector Code 06 - AxoMach HDR, 4 Way, Female, In-line Jack (with 8 HDR cables)	18
1.6.2.7	Connector Code 07 - AxoMach HDR, 1 Way, Female, Panel Mount Jack (with 2 HDR cables)	19
1.6.2.8	Connector Code 08 - AxoMach HDR, 2 Way, Female, Panel Mount Jack (with 4 HDR cables)	20
1.6.2.9	Connector Code 09 - AxoMach HDR, 4 Way, Female, Panel Mount Jack (with 8 HDR cables)	21
1.6.2.10	Connector Code 10 - SpaceFibre HDR, Male, In-line Plug (with 4 HDR cables)	22
1.6.2.11	Connector Code 11 - SpaceFibre HDR, Female, In-line Jack (with 4 HDR cables)	23
1.6.2.12	Mated Connector Dimensions	24
1.6.2.13	Connector Codes 12 to 16 – SMA Male and Female Connectors (ESCC Types)	24
1.6.2.14	Connector Code 17 - SMA Connector, Male, Straight Plug (Axon Type P567525)	24
1.6.2.15	Connector Code 18 - SpaceFibre HDR, Female, Panel Mount Jack (with 4 HDR cables)	25
1.6.3	Connector Interface Dimensions (Contact Height) (for Connector Codes 01 to 11, 18)	26
1.7	ADD-ON COMPONENTS	26
1.7.1	Connectors	26
1.7.2	Cable	26
1.8	MATERIALS AND FINISHES	27
1.8.1	Connectors	27
1.8.2	Cable	27
2	REQUIREMENTS	28
2.1	GENERAL	28



2.1.1	Deviations from the Generic Specification	28
2.1.1.1	Deviations from Qualification Testing – Chart F4A	28
2.1.1.2	Deviations from Periodic Testing – Chart F4B	28
2.2	MARKING	28
2.3	ENVIRONMENTAL AND MECHANICAL TESTS	28
2.4	ROOM TEMPERATURE ELECTRICAL MEASUREMENTS	30
2.5	INTERMEDIATE AND END-POINT ELECTRICAL MEASUREMENTS	32
APPENDIX A		37

1 GENERAL

1.1 SCOPE

This specification details the ratings, physical and electrical characteristics and test and inspection data for the range of components specified below. It supplements the requirements of, and shall be read in conjunction with, the ESCC Generic Specification listed under Applicable Documents.

1.2 APPLICABLE DOCUMENTS

The following documents form part of this specification and shall be read in conjunction with it:

- (a) ESCC Generic Specification No. [3409](#), High Data Rate Cable Assemblies.
- (b) ESCC Detail Specification No. [3402/001](#), RF Coaxial Connectors, Type SMA, 50ohms (Male Contact).
- (c) ESCC Detail Specification No. [3402/002](#), RF Coaxial Connectors, Type SMA, 50ohms (Female Contact).
- (d) ECSS-E-ST-50-11, Space Engineering Standard for SpaceFibre – Very High-Speed Serial Link.

1.3 TERMS, DEFINITIONS, ABBREVIATIONS, SYMBOLS AND UNITS

For the purpose of this specification, the terms, definitions, abbreviations, symbols and units specified in ESCC Basic Specification No. [21300](#) shall apply.

1.4 THE ESCC COMPONENT NUMBER AND COMPONENT TYPE VARIANTS

1.4.1 The ESCC Component Number

The ESCC Component Number shall be constituted as follows:

Example: 340900101123ABC

- Detail Specification Reference: 3409001
- Component Type Variant Number: 01 (see Note 1)
- Manufacturer Specific Assembly Identification: 123ABC (as applicable) where:
 - 123ABC: A unique reference of up to a maximum of 20 digits and/or letters, allocated by the applicable Manufacturer to a specific cable assembly design (see Para. 1.4.3).

NOTES:

1. Marking of the type variant number is mandatory. No further reference to type variant number is made in this specification.

1.4.2 Range of Components

The range of components applicable to this specification are as follows:

Description	Physical Dimensions	Weight Max (g)
HDR Cable Assembly (All configurations - see Note 1)	See Para. 1.6	See Note 2

NOTES:

- The available configurations for cable assemblies including details of the available connector types and wiring types shall be as indicated in Para. 1.4.2.1.
- The cable assembly total maximum weight is calculated from the individual maximum weights of the various piece parts, as applicable, as follows:
 - Each connector:

Connector Code (see Para. 1.4.2.1)	Description	Weight Max (g)
01	AxoMach HDR, 1 Way, Male, In-line Plug	6
02	AxoMach HDR, 2 Way, Male, In-line Plug	9
03	AxoMach HDR, 4 Way, Male, In-line Plug	15
04	AxoMach HDR, 1 Way, Female, In-line Jack	6
05	AxoMach HDR, 2 Way, Female, In-line Jack	8
06	AxoMach HDR, 4 Way, Female, In-line Jack	12
07	AxoMach HDR, 1 Way, Female, Panel Mount Jack	8
08	AxoMach HDR, 2 Way, Female, Panel Mount Jack	10
09	AxoMach HDR, 4 Way, Female, Panel Mount Jack	15
10	SpaceFibre HDR, Male, In-line Plug	7
11	SpaceFibre HDR, Female, In-line Jack	8
12, 13	SMA Connector, Male (ESCC Types)	See ESCC No. 3402/001
14, 15, 16	SMA Connector, Female (ESCC Types)	See ESCC No. 3402/002
17	SMA Connector, Male, Straight Plug (Axon Type)	3
18	SpaceFibre HDR, Female, Panel Mount Jack	7.3

- Each cable (all configurations): 17g/m maximum for each individual cable (see Paras. 1.6.1 and 1.6.2)

1.4.2.1 Cable Assembly Configuration

The available connector types and wiring types that can be used for any particular cable assembly are as follows:

(a) Connector Types

The available connector type(s) at side A and side B of the HDR cable assembly (see Para. 1.6.2) are as follows. Multiple connectors of one or more types may be included on one side of of the cable assembly depending on the required configuration.

Note: Connector codes are listed for correlation purposes only.

Connector Type	Connector Code	Remarks
AxoMach HDR, 1 Way, Male, In-line Plug	01	Used for side A and/or B. See Note 1 for available combinations.
AxoMach HDR, 2 Way, Male, In-line Plug	02	Used for side A and/or B. See Note 1 for available combinations.
AxoMach HDR, 4 Way, Male, In-line Plug	03	Used for side A and/or B. See Note 1 for available combinations.
AxoMach HDR, 1 Way, Female, In-line Jack	04	Used for side A and/or B. See Note 1 for available combinations.
AxoMach HDR, 2 Way, Female, In-line Jack	05	Used for side A and/or B. See Note 1 for available combinations.
AxoMach HDR, 4 Way, Female, In-line Jack	06	Used for side A and/or B. See Note 1 for available combinations.
AxoMach HDR, 1 Way, Female, Panel Mount Jack	07	Used for side A and/or B. See Note 1 for available combinations.
AxoMach HDR, 2 Way, Female, Panel Mount Jack	08	Used for side A and/or B. See Note 1 for available combinations.
AxoMach HDR, 4 Way, Female, Panel Mount Jack	09	Used for side A and/or B. See Note 1 for available combinations.
SpaceFibre HDR, Male, In-line Plug	10	Used for side A and/or B. See Note 1 for available combinations.
SpaceFibre HDR, Female, In-line Jack	11	Used for side A and/or B. See Note 1 for available combinations.
SMA Connector, Male, Straight Plug: ESCC 340200101B	12	Used for side A and/or B. See Note 1 for available combinations.
SMA Connector, Male, Right Angle Plug: ESCC 340200109B	13	Used for side A and/or B. See Note 1 for available combinations.
SMA Connector, Female, Straight Jack: ESCC 340200201B	14	Used for side A and/or B. See Note 1 for available combinations.
SMA Connector, Female, Straight Jack, Back Mounting, 2-Hole Flange-Mounted: ESCC 340200209B	15	Used for side A and/or B. See Note 1 for available combinations.
SMA Connector, Female, Straight Jack, Back Mounting, 4-Hole Flange-Mounted: ESCC 340200268B	16	Used for side A and/or B. See Note 1 for available combinations.
SMA Connector, Male, Straight Plug (Axon Type P567525)	17	Used for side A and/or B. See Note 1 for available combinations.
SpaceFibre HDR, Female, Panel Mount Jack	18	Used for side A and/or B. See Note 1 for available combinations
No Connector	00	Pigtails; Used in pairs Used only for side B. See Note 1 for available combinations.

NOTES:

- Available combinations of the above listed connector types within a single cable assembly are indicated by 'X' in the table below:

		Connector Code Side B																		
		01	02	03	04	05	06	07	08	09	10	11	12	13	14	15	16	17	18	00
Connector Code Side A	01	X	X	X	X	X	X	X	X	X			X	X	X	X	X	X		X
	02	X	X	X	X	X	X	X	X	X			X	X	X	X	X	X		X
	03	X	X	X	X	X	X	X	X	X			X	X	X	X	X	X		X
	04	X	X	X	X	X	X	X	X	X			X	X	X	X	X	X		X
	05	X	X	X	X	X	X	X	X	X			X	X	X	X	X	X		X
	06	X	X	X	X	X	X	X	X	X			X	X	X	X	X	X		X
	07	X	X	X	X	X	X	X	X	X			X	X	X	X	X	X		X
	08	X	X	X	X	X	X	X	X	X			X	X	X	X	X	X		X
	09	X	X	X	X	X	X	X	X	X			X	X	X	X	X	X		X
	10										X	X	X	X	X	X	X	X	X	X
	11										X	X	X	X	X	X	X	X	X	X
	12	X	X	X	X	X	X	X	X	X	X	X	X*	X*	X*	X*	X*	X*		
	13	X	X	X	X	X	X	X	X	X	X	X	X*	X*	X*	X*	X*	X*		
	14	X	X	X	X	X	X	X	X	X	X	X	X*	X*	X*	X*	X*	X*		
	15	X	X	X	X	X	X	X	X	X	X	X	X*	X*	X*	X*	X*	X*		
	16	X	X	X	X	X	X	X	X	X	X	X	X*	X*	X*	X*	X*	X*		
	17	X	X	X	X	X	X	X	X	X	X	X	X*	X*	X*	X*	X*	X*		
	18										X	X							X	X

* A cable assembly that has Connector Codes 12 to 17 (SMA connectors) on both sides A and B shall consist of 2 pairs of connectors and a pair of cables.

- Examples of the various cable assembly configurations are given below:

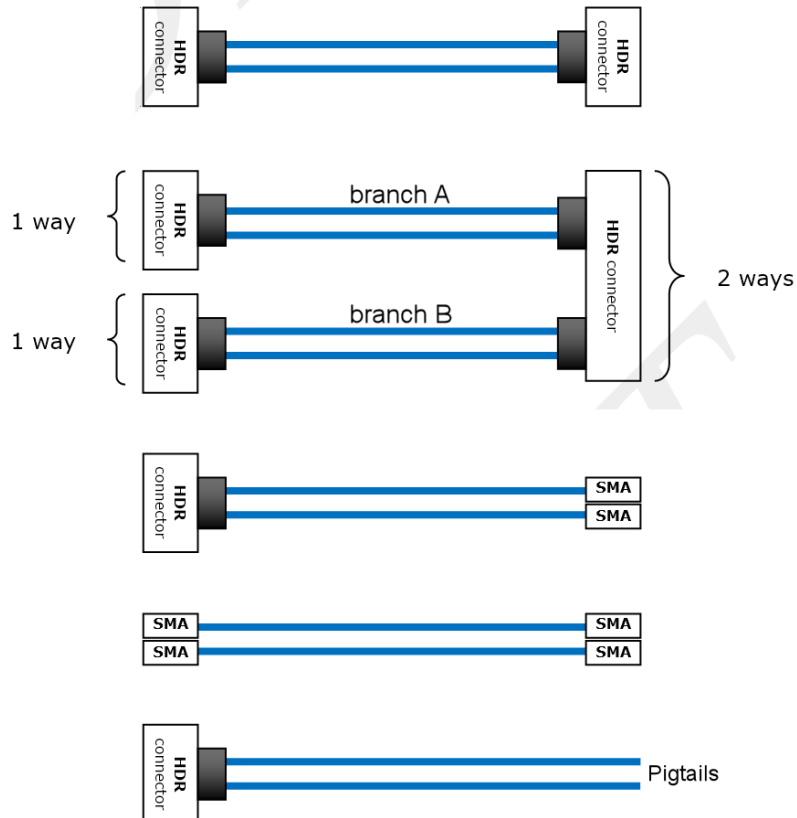

(b) Wiring Types

The type of wiring employed between the contacts of the two sides of the cable assembly may be either direct or indirect as follows:

i. Direct Wiring

For direct wiring of the cable assembly, each contact number in the connector(s) on side A shall be connected to its matching contact number in the connector(s) on side B. e.g. Contacts 1, 2, 3, 4 of the connector on side A are connected to contacts 1, 2, 3, 4 respectively, of the connector on side B.

ii. Indirect Wiring

For indirect wiring of the cable assembly, each contact number in the connector(s) on side A shall be connected to the contact number of the connector on side B read in reverse order.

e.g. Contact 1, 2, 3, 4 of the connector on side A are connected to contacts 4, 3, 2, 1 respectively, of the connector on side B.

Note: If one side of the cable assembly employs more than a single connector, the effective contact numbers shall be based on a sequential grouping of these connectors in the same order as their individual contact numbers.

1.4.3 Manufacturer Specific Assembly Identification

A Cable Assembly Design Drawing shall be produced by the Manufacturer after negotiation with the Orderer and shall be held under configuration control by the Manufacturer who will allocate a unique Manufacturer Specific Assembly Identification when a request for a cable assembly is received.

Each Cable Assembly Design Drawing shall include the following information:

- (a) The cable assembly configuration details and dimensions as required by Paras. 1.4.2.1 and 1.6.1 herein. This shall include as a minimum:
- The connector type used in each location of the cable assembly (see Para. 1.4.2.1(a))
 - The applicable wiring type used for each connected pair of connectors in the cable assembly (see Para. 1.4.2.1(b))
 - The nominal length, L, of each branch of the cable assembly (see Para. 1.6.1).
 - Details of any specific angling or twisting of cables used in the cable assembly.
- (b) The ESCC Component Number for the cable assembly, including the Manufacturer Specific Assembly Identification (see Para. 1.4.1).

1.5 MAXIMUM RATINGS

The maximum ratings shall not be exceeded at any time during use or storage.

Maximum ratings shall only be exceeded during testing to the extent specified in this specification and when stipulated in Test Methods and Procedures of the ESCC Generic Specification.

Characteristics	Symbols	Maximum Ratings	Units	Remarks
Maximum Operating Data Rate	DR_{max}	10	Gb/s	
Operating Frequency Range	f_R	≤ 10	GHz	
Working Voltage	U_R	150	Vrms	At sea level. Note 1
Rated Current	I_R	1	A	Each contact
Minimum Dynamic Bending Radius	R_{min}	25	mm	
Operating Temperature Range	T_{op}	-55 to +125	°C	T_{amb}
Storage Temperature Range	T_{stg}	-55 to +125	°C	
Coupling Nut Torque	T_q	170	N.cm	Coupling Proof Torque Note 2

NOTES:

1. Between contacts, and contacts and shell.
2. Only applicable for Connector Codes 12 to 17. Whenever a test is performed on mated pairs of connectors, the pairs shall be torqued at 80 to 120N.cm.

1.6 PHYSICAL DIMENSIONS

1.6.1 Cable Assembly Dimensions

Examples:

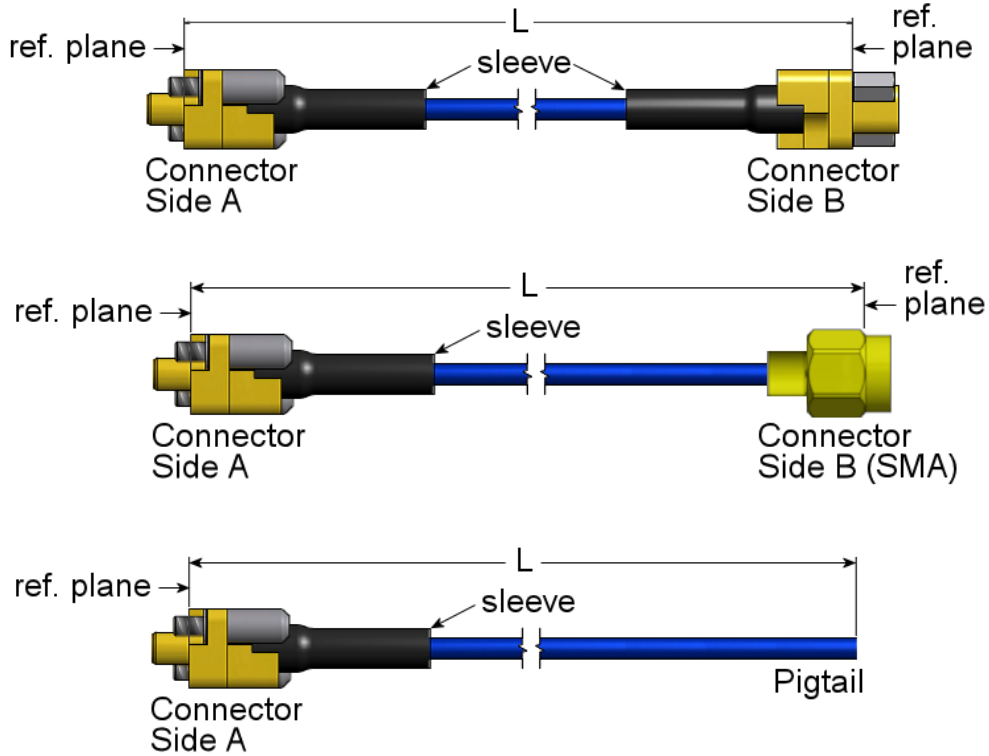

Symbols	Dimensions (mm)		Tolerance (mm)
	Min	Max	
L (Note 2)	100 (Note 3)	9999	(+30 -0) for L < 1000 (+50 -0) for L ≥ 1000

NOTES:

1. For connector dimensions, see Para. 1.6.2 (as applicable) and Para. 1.6.3.
2. L = nominal length.
3. For cable assemblies with more than one branch, L may be different for each branch.
4. For any cable assembly that is to be used in an application that requires the cables to be angled or twisted, the minimum length shall be as follows:
 - 100mm for any cable assembly that has no more than 2 individual HDR cables on any one of its connectors.
 - 200mm for any cable assembly that has no more than 4 individual HDR cables on any one of its connectors.
 - 500mm for any cable assembly that has 8 individual HDR cables on any one of its connectors.

1.6.2 Connectors

1.6.2.1 *Connector Code 01 – AxoMach HDR, 1 Way, Male, In-line Plug (with 2 HDR cables)*

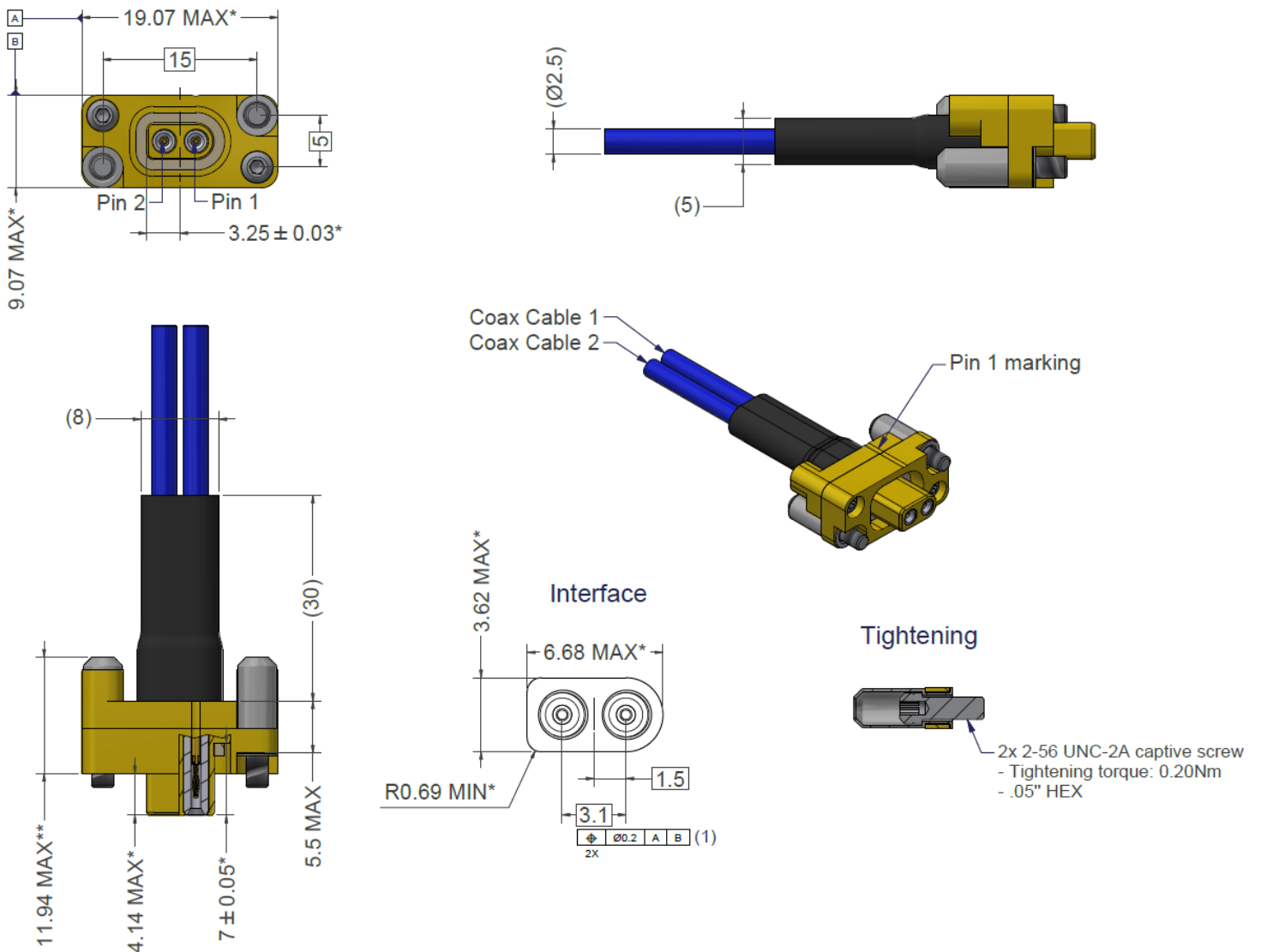

NOTES:

1. All dimensions are in mm.
2. Dimensions with a single asterisk (*) may be checked during the Manufacturer's internal processing. Dimensions with a double asterisk (**) shall be checked after assembly of the cable assembly.
3. For connector interface dimensions, see also Para. 1.6.3.
4. Mating torque: 0.2N.m ±5%.
5. Contact and cable identification: Contact and cable Nos. 1 and 2 are indicated by the physical configuration. In addition, contact No. 1 and cable 1 No. 1 are indicated by an index mark on the shell above pin 1 (as shown above).
6. Cable diameter: 2.5 ±0.1mm for all cables.

1.6.2.2 Connector Code 02 - AxoMach HDR, 2 Way, Male, In-line Plug (with 4 HDR cables)

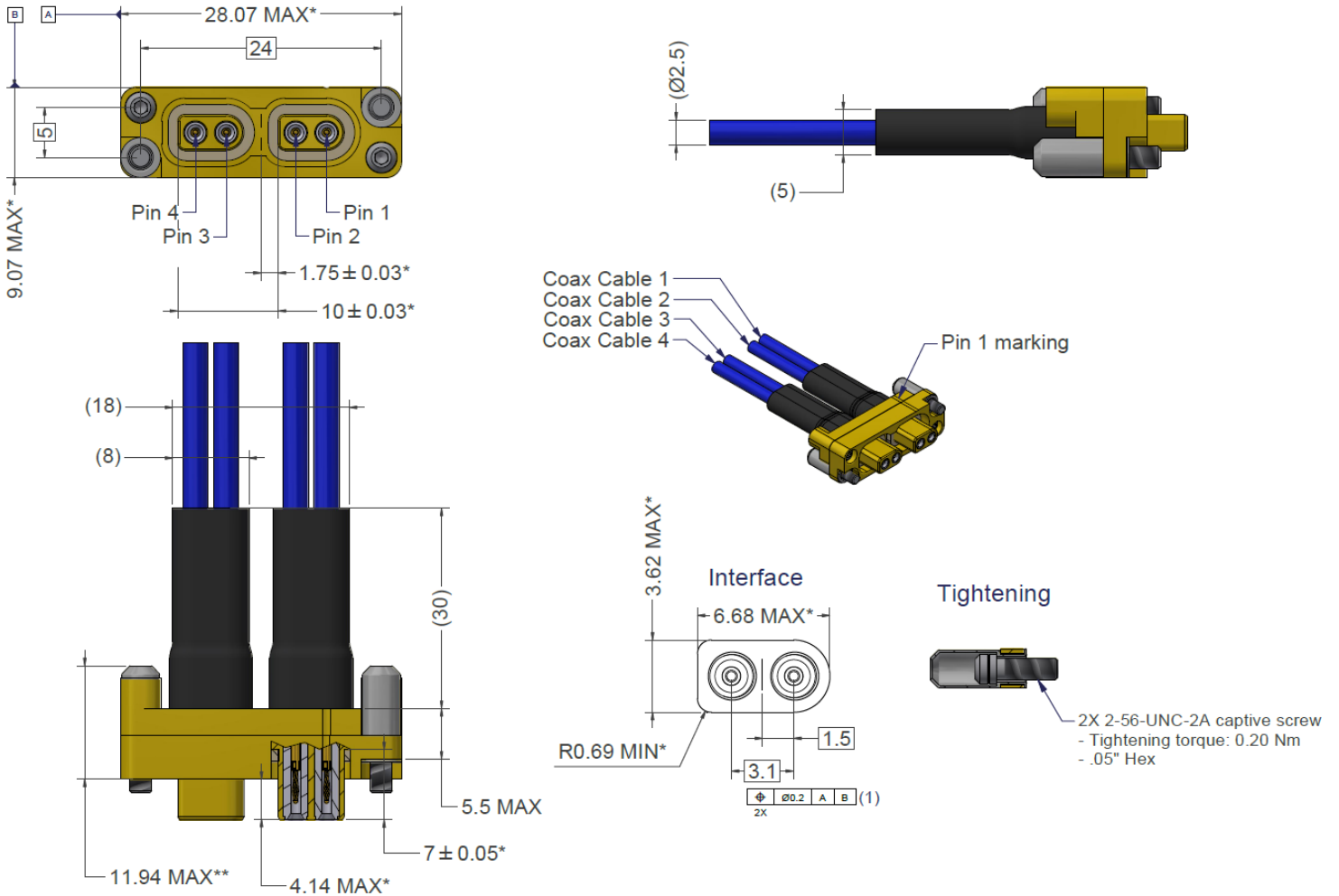

NOTES:

1. All dimensions are in mm.
2. Dimensions with a single asterisk (*) may be checked during the Manufacturer's internal processing. Dimensions with a double asterisk (**) shall be checked after assembly of the cable assembly.
3. For connector interface dimensions, see also Para. 1.6.3.
4. Mating torque: 0.2N.m ±5%.
5. Contact and cable identification: Contact and cable Nos. 1 to 4 are indicated by the physical configuration. In addition, contact No. 1 and cable 1 No. 1 are indicated by an index mark on the shell above pin 1 (as shown above).
6. Cable diameter: 2.5 ±0.1mm for all cables.

1.6.2.3 Connector Code 03 - AxoMach HDR, 4 Way, Male, In-line Plug (with 8 HDR cables)

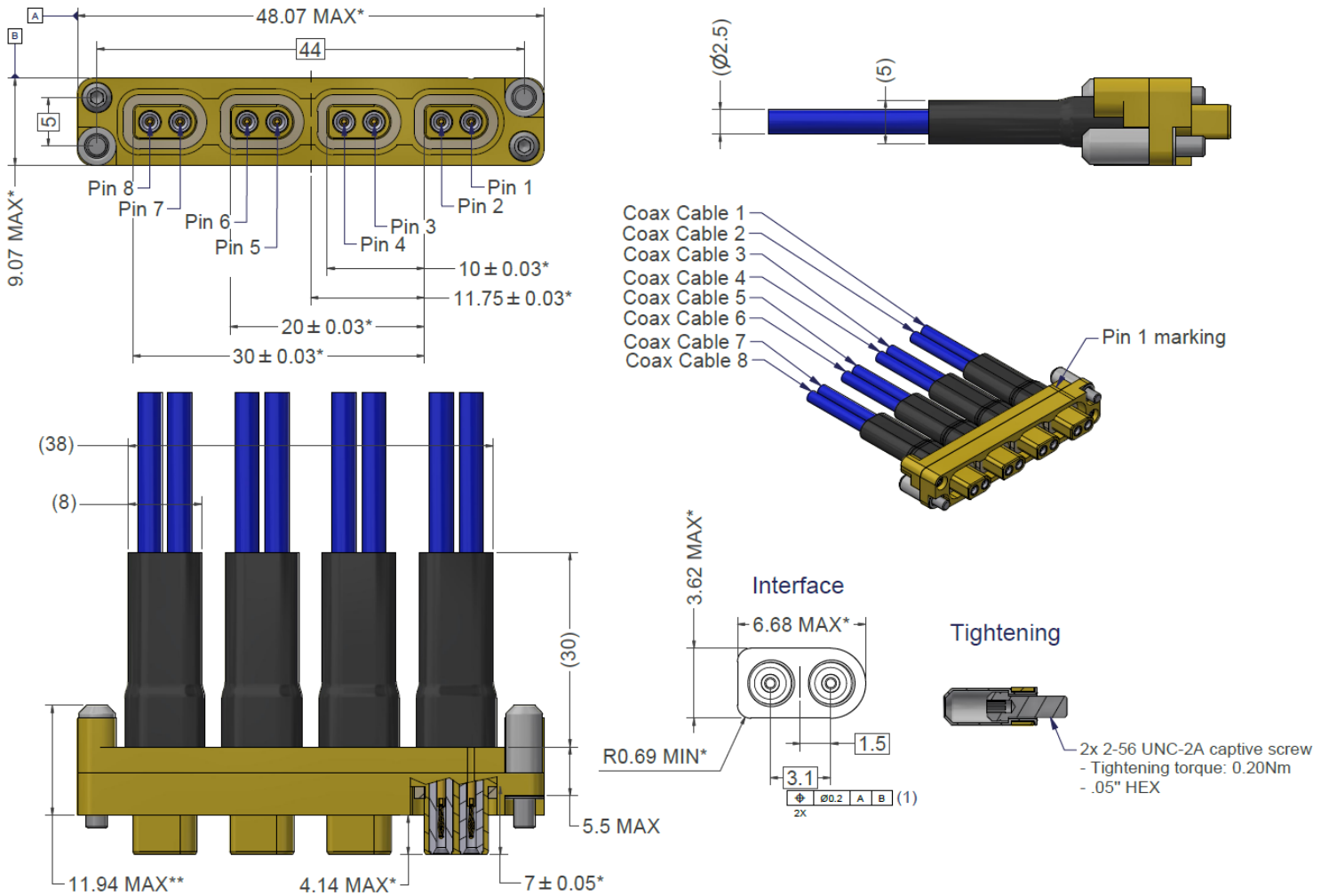

NOTES:

1. All dimensions are in mm.
2. Dimensions with a single asterisk (*) may be checked during the Manufacturer's internal processing. Dimensions with a double asterisk (**) shall be checked after assembly of the cable assembly.
3. For connector interface dimensions, see also Para. 1.6.3.
4. Mating torque: 0.2N.m ±5%.
5. Contact and cable identification: Contact and cable Nos. 1 to 8 are indicated by the physical configuration. In addition, contact No. 1 and cable 1 No. 1 are indicated by an index mark on the shell above pin 1 (as shown above).
6. Cable diameter: 2.5 ± 0.1mm for all cables.

1.6.2.4 Connector Code 04 - AxoMach HDR, 1 Way, Female, In-line Jack (with 2 HDR cables)

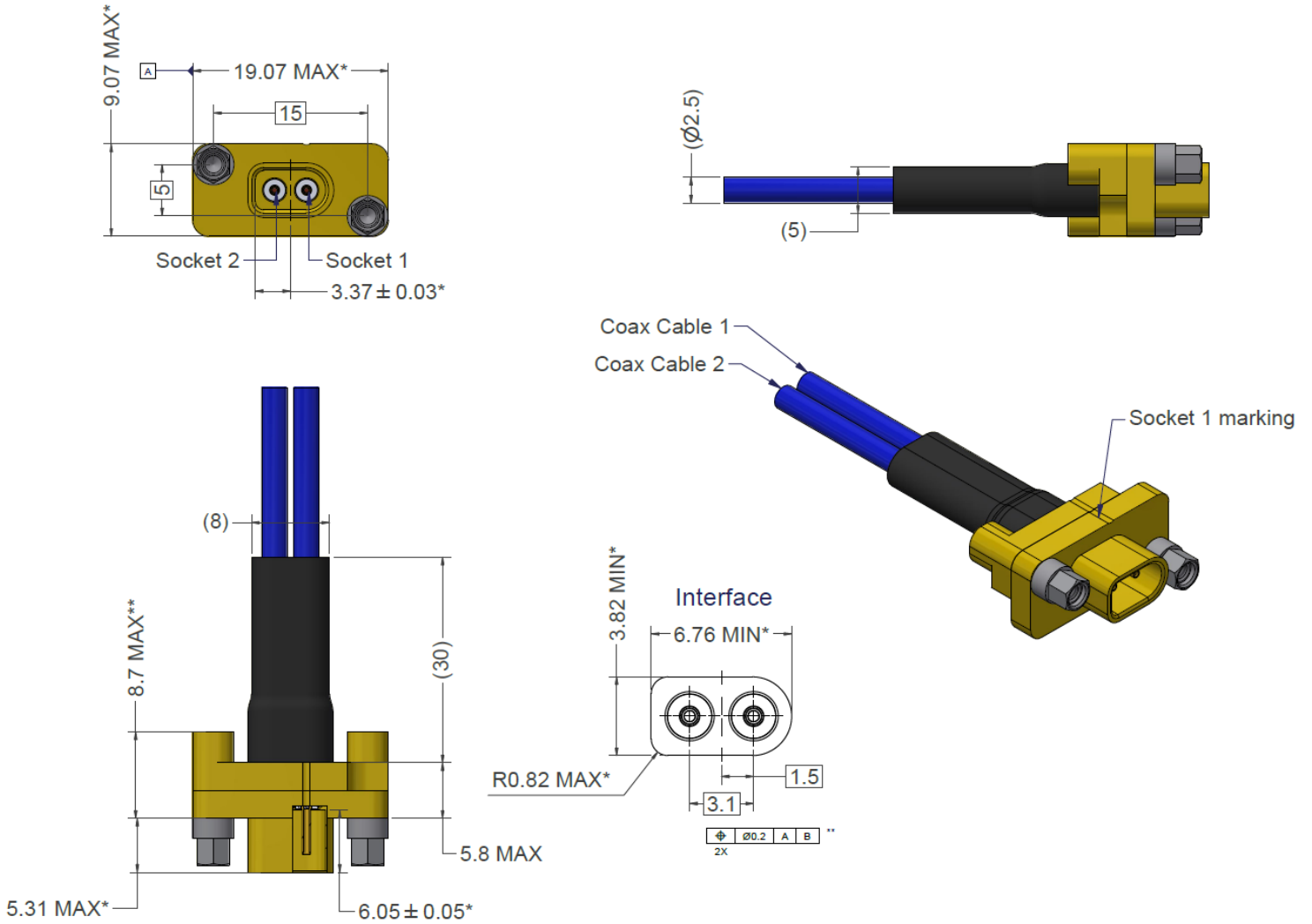

NOTES:

1. All dimensions are in mm.
2. Dimensions with a single asterisk (*) may be checked during the Manufacturer's internal processing. Dimensions with a double asterisk (**) shall be checked after assembly of the cable assembly.
3. For connector interface dimensions, see also Para. 1.6.3.
4. Contact and cable identification: Contact and cable Nos. 1 and 2 are indicated by the physical configuration. In addition, contact No. 1 and cable 1 No. 1 are indicated by an index mark on the shell above socket 1 (as shown above).
5. Cable diameter: 2.5 ± 0.1 mm for all cables.

1.6.2.5 Connector Code 05 - AxoMach HDR, 2 Way, Female, In-line Jack (with 4 HDR cables)

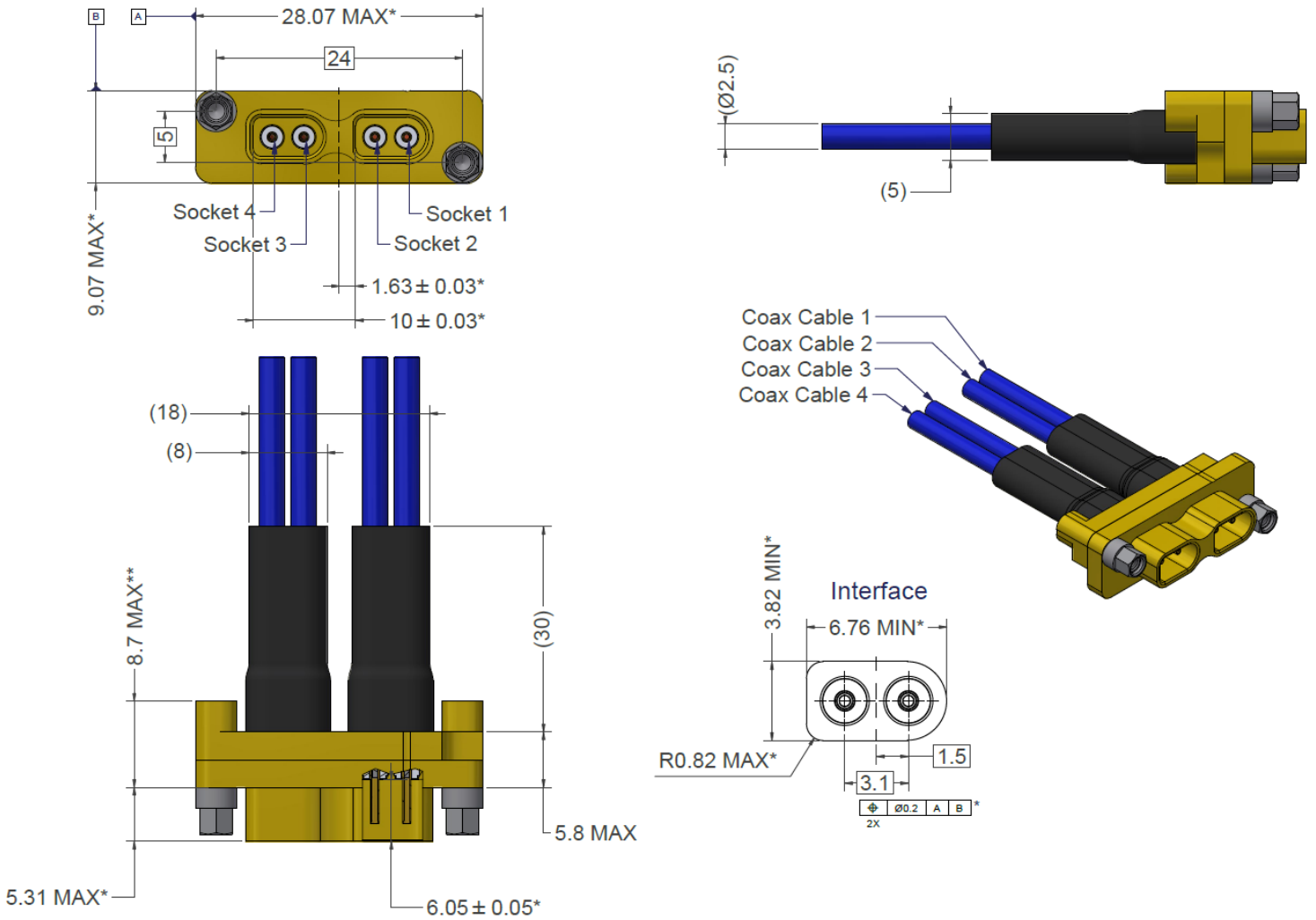

NOTES:

1. All dimensions are in mm.
2. Dimensions with a single asterisk (*) may be checked during the Manufacturer's internal processing. Dimensions with a double asterisk (**) shall be checked after assembly of the cable assembly.
3. For connector interface dimensions, see also Para. 1.6.3.
4. Contact and cable identification: Contact and cable Nos. 1 to 4 are indicated by the physical configuration. In addition, contact No. 1 and cable 1 No. 1 are indicated by an index mark on the shell above socket 1 (as shown above).
5. Cable diameter: 2.5 ± 0.1mm for all cables.

1.6.2.6 Connector Code 06 - AxoMach HDR, 4 Way, Female, In-line Jack (with 8 HDR cables)

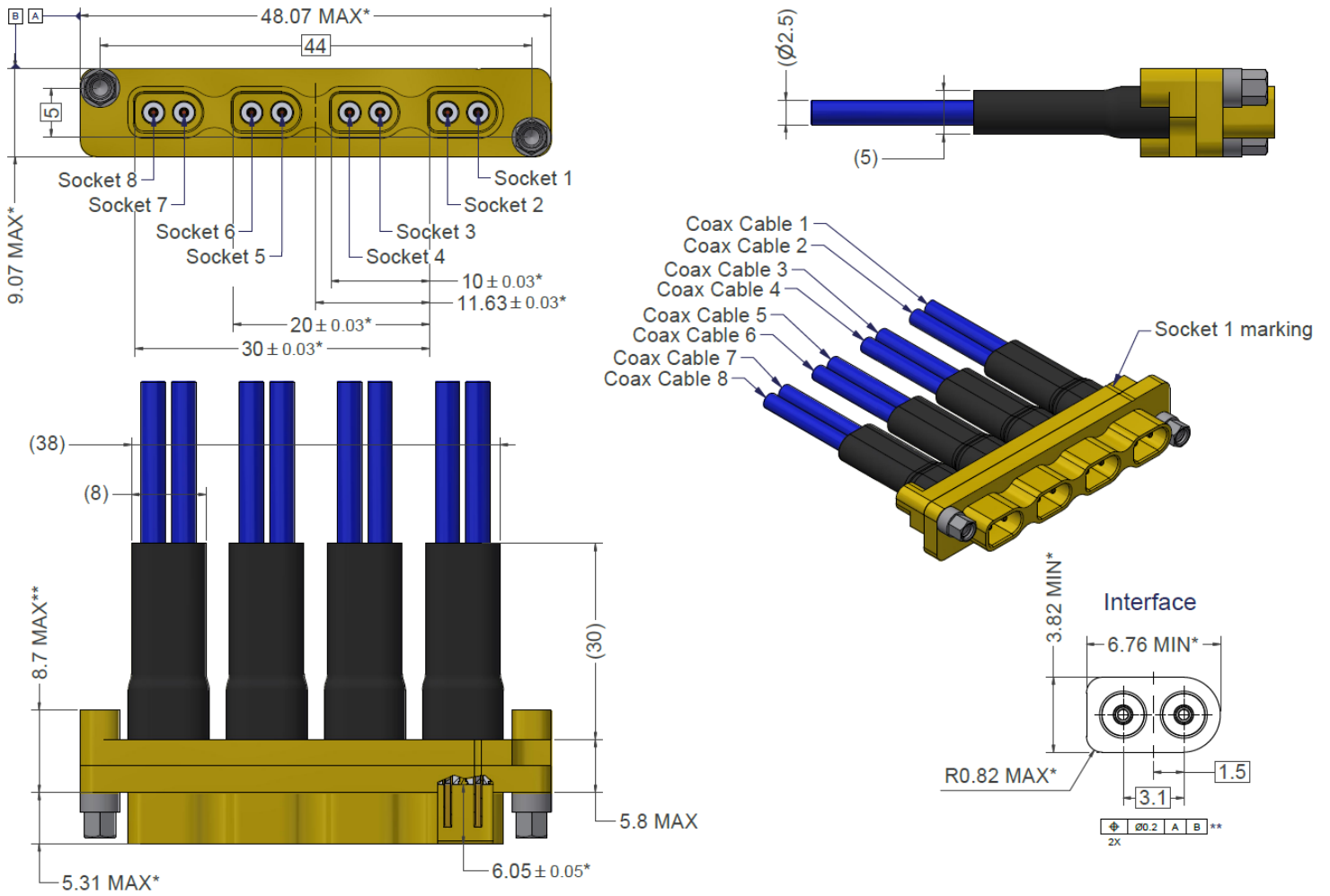

NOTES:

1. All dimensions are in mm.
2. Dimensions with a single asterisk (*) may be checked during the Manufacturer's internal processing. Dimensions with a double asterisk (**) shall be checked after assembly of the cable assembly.
3. For connector interface dimensions, see also Para. 1.6.3.
4. Contact and cable identification: Contact and cable Nos. 1 to 8 are indicated by the physical configuration. In addition, contact No. 1 and cable 1 No. 1 are indicated by an index mark on the shell above socket 1 (as shown above).
5. Cable diameter: 2.5 ± 0.1mm for all cables.

1.6.2.7 Connector Code 07 - AxoMach HDR, 1 Way, Female, Panel Mount Jack (with 2 HDR cables)

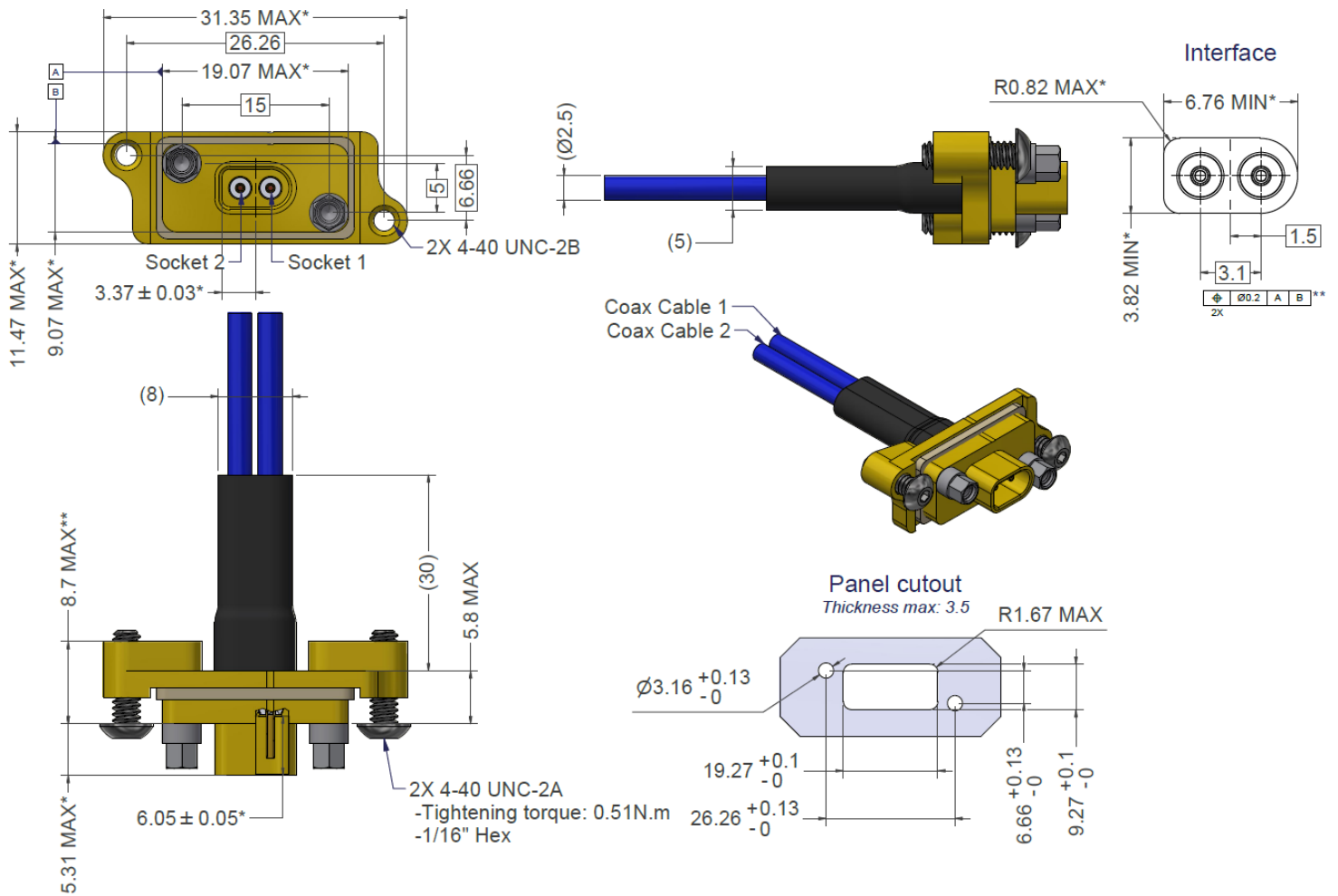

NOTES:

1. All dimensions are in mm.
2. Dimensions with a single asterisk (*) may be checked during the Manufacturer's internal processing. Dimensions with a double asterisk (**) shall be checked after assembly of the cable assembly.
3. For connector interface dimensions, see also Para. 1.6.3.
4. Mounting torque: 0.51N.m ±5%.
5. Contact and cable identification: Contact and cable Nos. 1 and 2 are indicated by the physical configuration. In addition, contact No. 1 and cable 1 No. 1 are indicated by an index mark on the shell above socket 1 (as shown above).
6. Maximum panel thickness: 3.5mm.
7. Cable diameter: 2.5 ±0.1mm for all cables.
8. Panel cut-out details are shown for information purposes only.

1.6.2.8 Connector Code 08 - AxoMach HDR, 2 Way, Female, Panel Mount Jack (with 4 HDR cables)

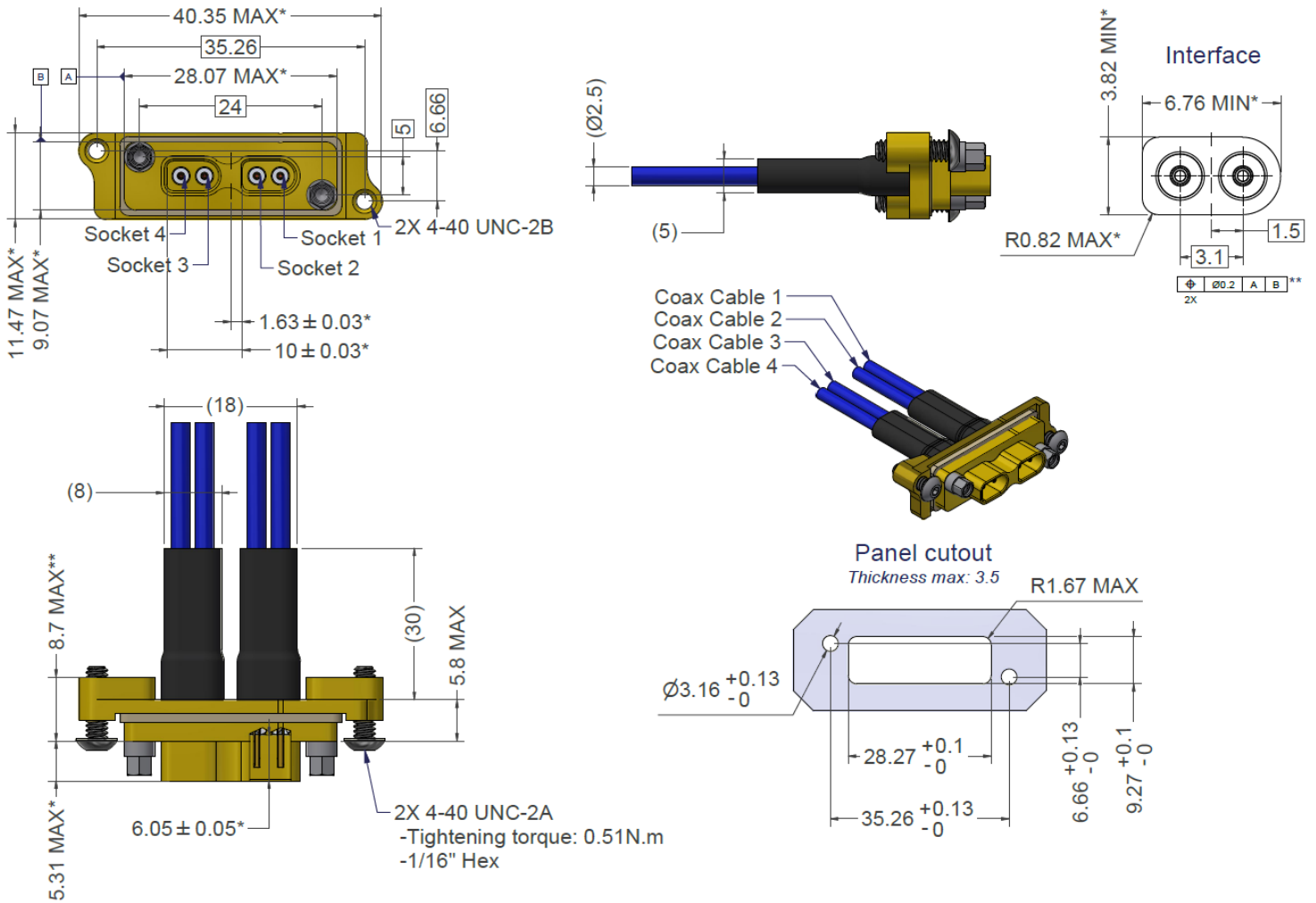

NOTES:

1. All dimensions are in mm.
2. Dimensions with a single asterisk (*) may be checked during the Manufacturer's internal processing. Dimensions with a double asterisk (**) shall be checked after assembly of the cable assembly.
3. For connector interface dimensions, see also Para. 1.6.3.
4. Mounting torque: 0.51N.m ±5%.
5. Contact and cable identification: Contact and cable Nos. 1 to 4 are indicated by the physical configuration. In addition, contact No. 1 and cable 1 No. 1 are indicated by an index mark on the shell above socket 1 (as shown above).
6. Maximum panel thickness: 3.5mm.
7. Cable diameter: 2.5 ±0.1mm for all cables.
8. Panel cut-out details are shown for information purposes only.

1.6.2.9 Connector Code 09 - AxoMach HDR, 4 Way, Female, Panel Mount Jack (with 8 HDR cables)

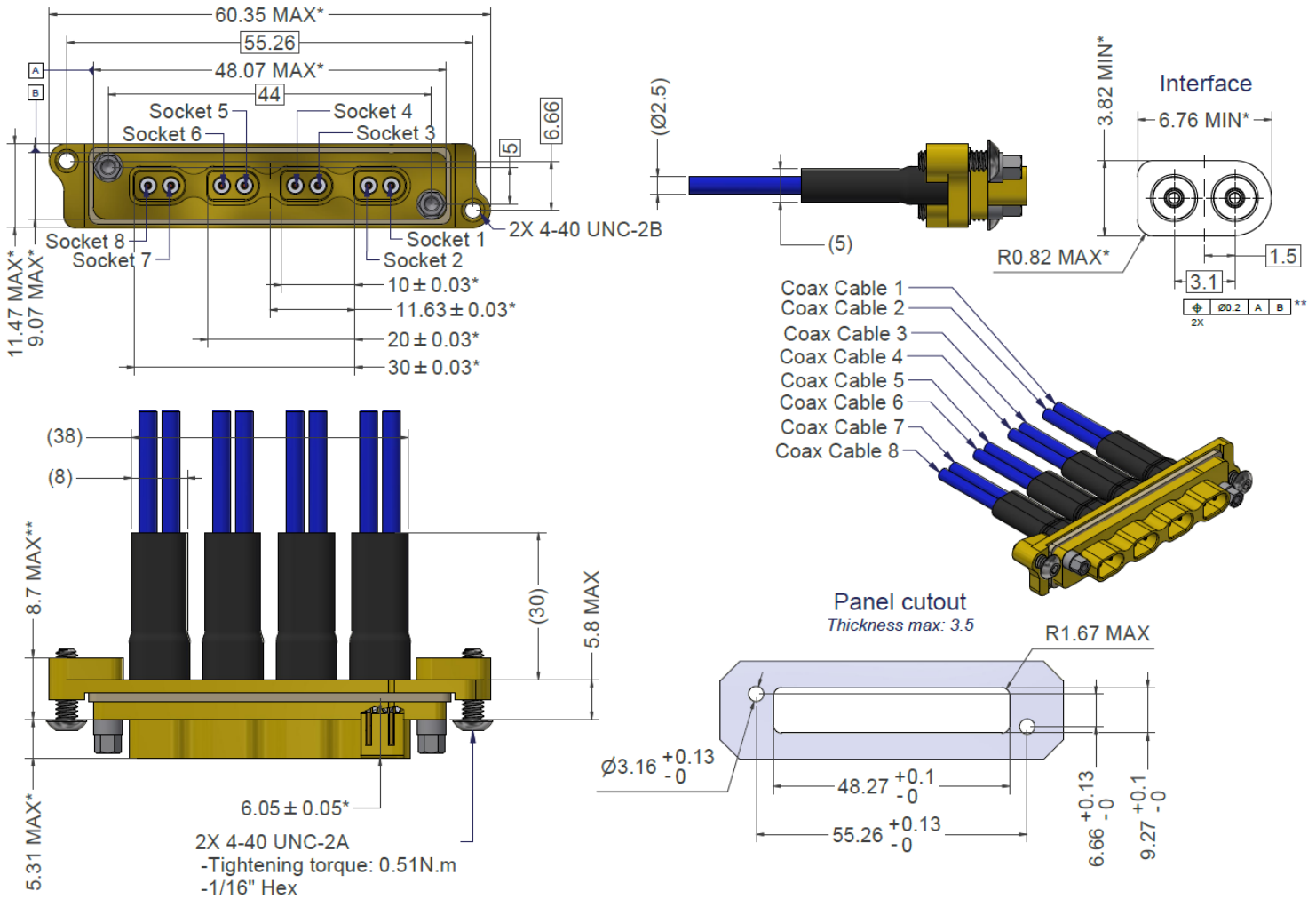

NOTES:

1. All dimensions are in mm.
2. Dimensions with a single asterisk (*) may be checked during the Manufacturer's internal processing. Dimensions with a double asterisk (**) shall be checked after assembly of the cable assembly.
3. For connector interface dimensions, see also Para. 1.6.3.
4. Mounting torque: 0.51N.m ±5%.
5. Contact and cable identification: Contact and cable Nos. 1 to 8 are indicated by the physical configuration. In addition, contact No. 1 and cable 1 No. 1 are indicated by an index mark on the shell above socket 1 (as shown above).
6. Maximum panel thickness: 3.5mm.
7. Cable diameter: 2.5 ±0.1mm for all cables.
8. Panel cut-out details are shown for information purposes only.

1.6.2.10 Connector Code 10 - SpaceFibre HDR, Male, In-line Plug (with 4 HDR cables)

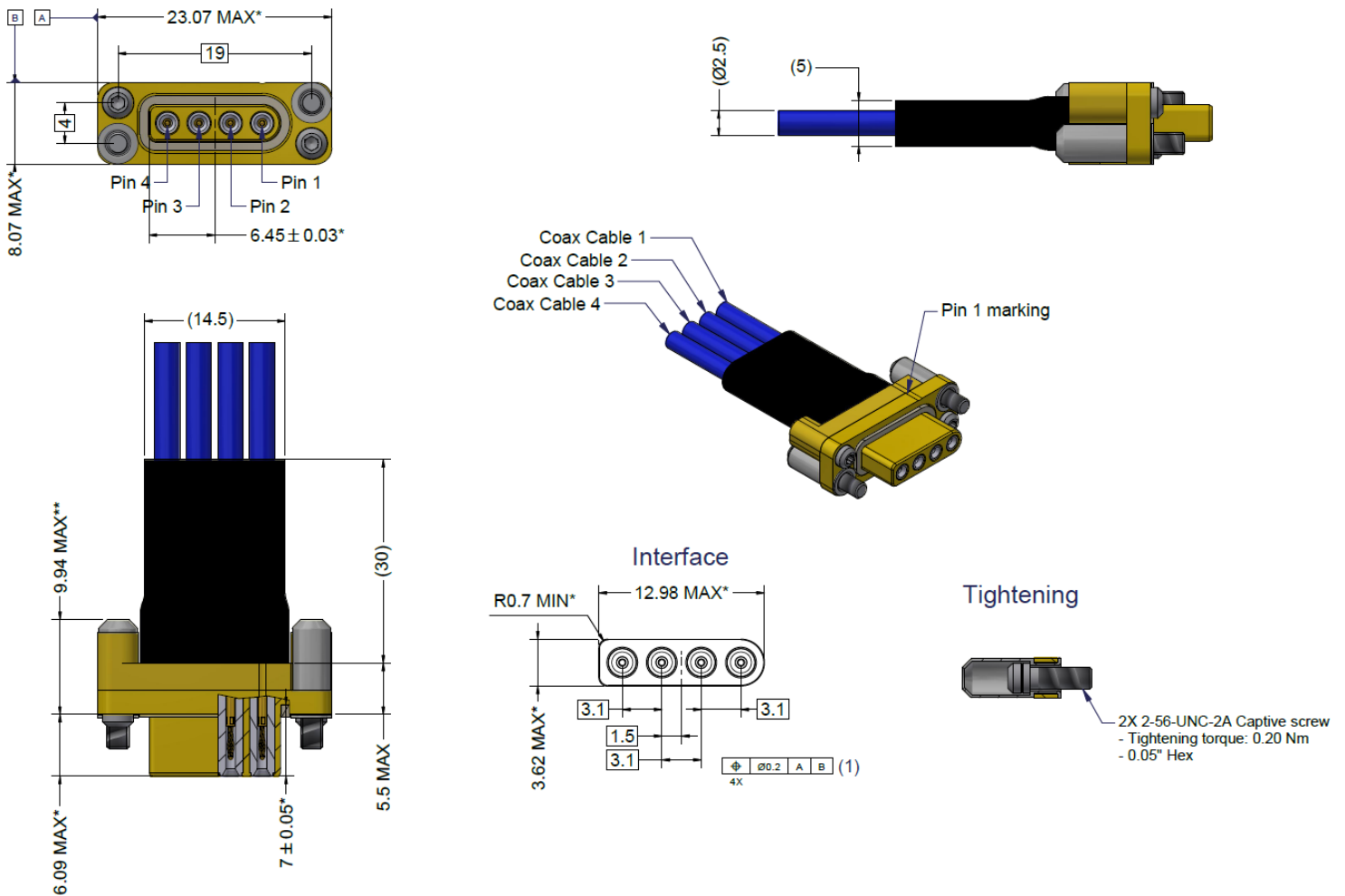

NOTES:

1. All dimensions are in mm.
2. Dimensions with a single asterisk (*) may be checked during the Manufacturer's internal processing. Dimensions with a double asterisk (**) shall be checked after assembly of the cable assembly.
3. For connector interface dimensions, see also Para. 1.6.3.
4. Mating torque: 0.2N.m ±5%.
5. Contact and cable identification: Contact and cable Nos. 1 to 4 are indicated by the physical configuration. In addition, contact No. 1 and cable 1 No. 1 are indicated by an index mark on the shell above pin 1 (as shown above).
6. Cable diameter: 2.5 ±0.1mm for all cables.

1.6.2.11 Connector Code 11 - SpaceFibre HDR, Female, In-line Jack (with 4 HDR cables)

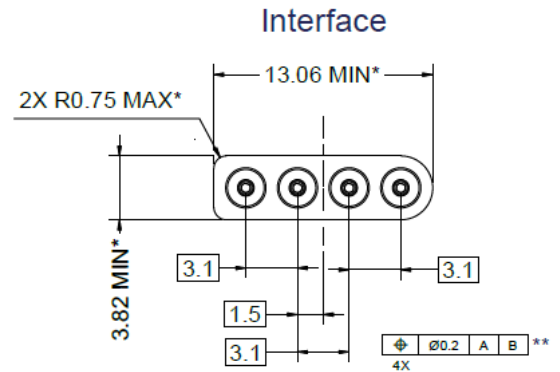
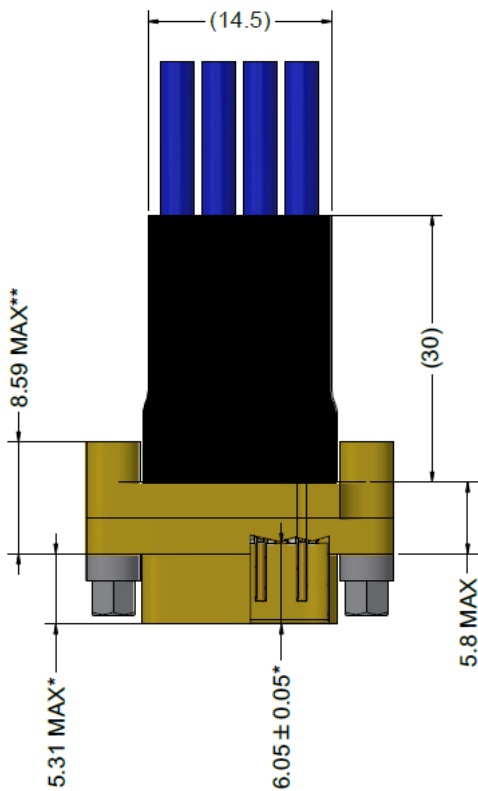
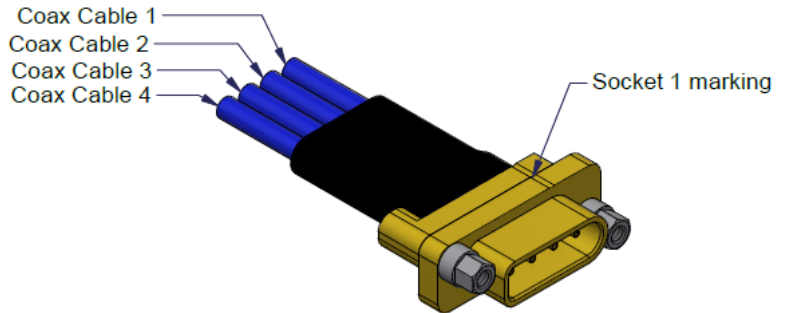
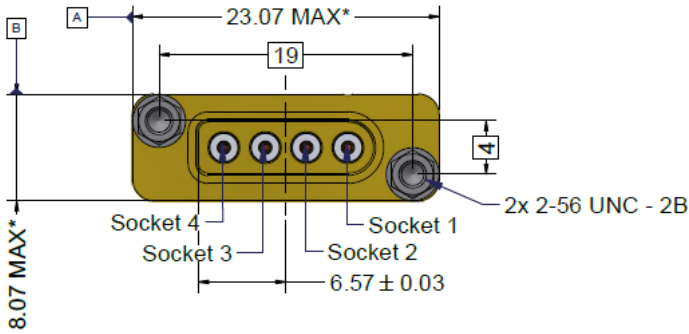

NOTES:

1. All dimensions are in mm.
2. Dimensions with a single asterisk (*) may be checked during the Manufacturer's internal processing. Dimensions with a double asterisk (**) shall be checked after assembly of the cable assembly.
3. For connector interface dimensions, see also Para. 1.6.3.
4. Contact and cable identification: Contact and cable Nos. 1 to 4 are indicated by the physical configuration. In addition, contact No. 1 and cable 1 No. 1 are indicated by an index mark on the shell above socket 1 (as shown above).
5. Cable diameter: 2.5 ± 0.1mm for all cables.

1.6.2.12 Mated Connector Dimensions

Examples:

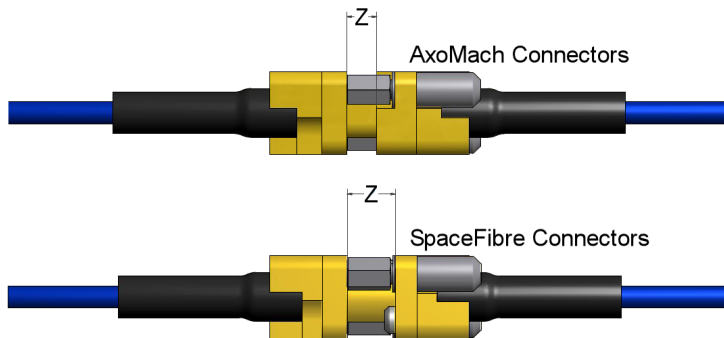

Symbols	Dimensions mm		Remarks
	Min	Max	
Z	-	3.4	When mating Connector Codes: 01 to 09 (AxoMach)
	-	5.4	When mating Connector Codes: 10, 11, 18 (SpaceFibre)

1.6.2.13 Connector Codes 12 to 16 – SMA Male and Female Connectors (ESCC Types)

For dimensions including interface dimensions, see ESCC Detail Specification Nos. [3402/001](#) and [3402/002](#), as applicable.

NOTES:

- Mating torque: 80 to 120N.cm.

1.6.2.14 Connector Code 17 - SMA Connector, Male, Straight Plug (Axon Type P567525)

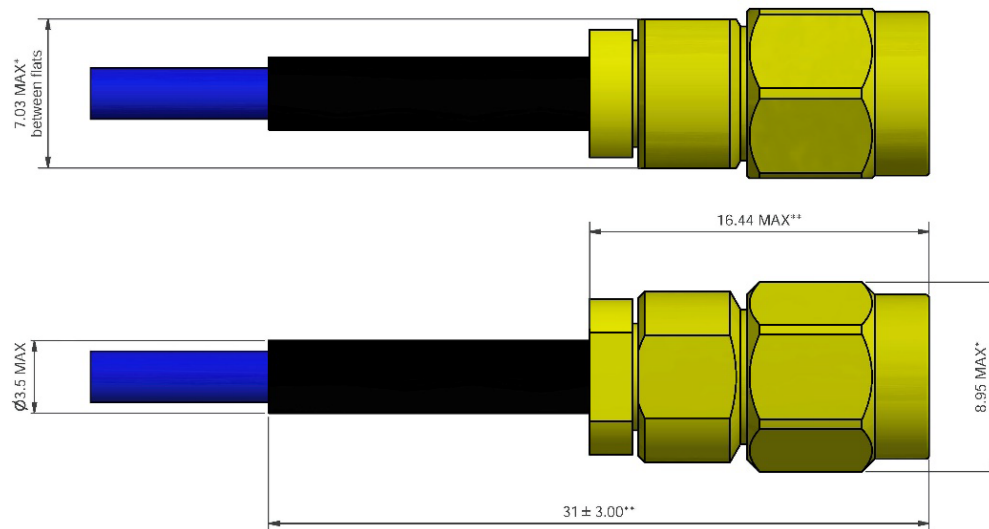

NOTES:

- All dimensions are in mm.
- Dimensions with a single asterisk (*) may be checked during the Manufacturer's internal processing. Dimensions with a double asterisk (**) shall be checked after assembly of the cable assembly.
- For connector interface dimensions, see ESCC Detail Specification Nos. [3402/001](#).
- Cable diameter: 2.5 ± 0.1mm.
- Mating torque: 80 to 120N.cm.

1.6.2.15 Connector Code 18 - SpaceFibre HDR, Female, Panel Mount Jack (with 4 HDR cables)

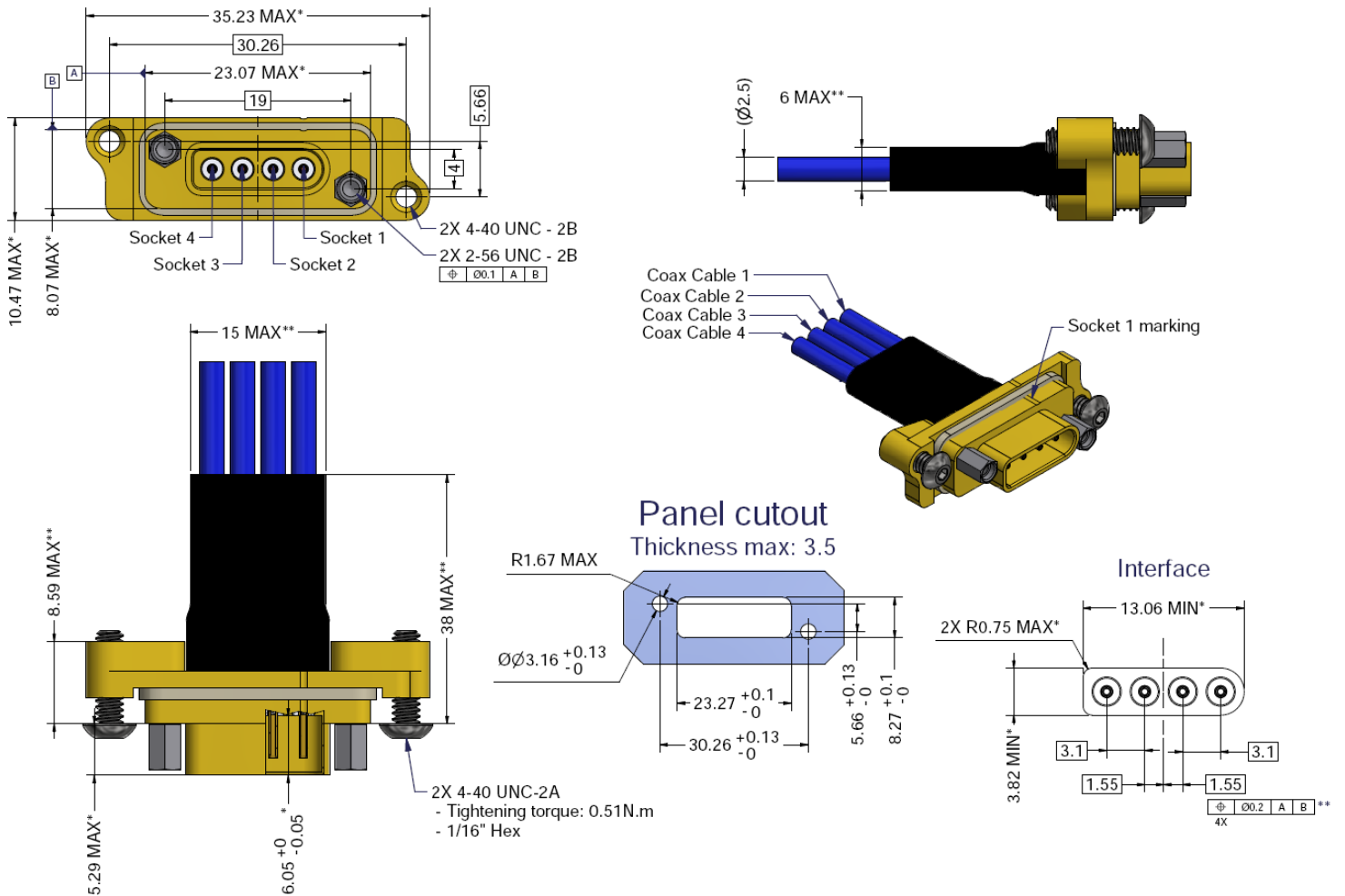

NOTES:

1. All dimensions are in mm.
2. Dimensions with a single asterisk (*) may be checked during the Manufacturer's internal processing. Dimensions with a double asterisk (**) shall be checked after assembly of the cable assembly.
3. For connector interface dimensions, see also Para. 1.6.3.
4. Mounting torque: 0.51N.m $\pm 5\%$.
5. Contact and cable identification: Contact and cable Nos. 1 to 4 are indicated by the physical configuration. In addition, contact No. 1 and cable 1 No. 1 are indicated by an index mark on the shell above socket 1 (as shown above).
6. Maximum panel thickness: 3.5mm.
7. Cable diameter: 2.5 ± 0.1 mm for all cables.
8. Panel cut-out details are shown for information purposes only.

1.6.3 Connector Interface Dimensions (Contact Height) (for Connector Codes 01 to 11, 18)

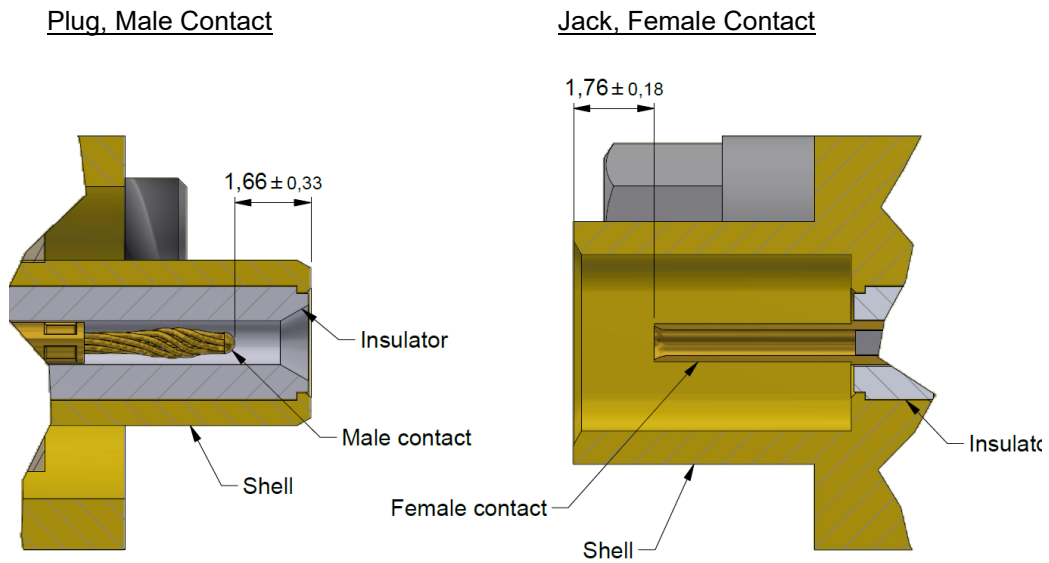

NOTES:

1. All dimensions are in mm.

1.7 ADD-ON COMPONENTS

1.7.1 Connectors

The connectors to be used in the components specified herein shall be as follows. They shall meet the requirements of this specification and the ESCC Generic Specification.

- Connector Codes 01 to 11, 18: HDR connectors types: AxoMach and SpaceFibre (as applicable).
- Connector Codes 12 to 16: SMA male and female connectors in accordance with ESCC Detail Specification Nos. [3402/001](#) and [3402/002](#), as applicable.
- Connector Code 17: SMA male connector, Axon type P567525, that complies with the requirements specified in ESCC Generic Specification No. [3402](#).

1.7.2 Cable

The cable to be used in the components specified herein shall be 2.5mm outer diameter, RF ePTFE, flexible, 50Ω, coaxial cable type AXOWAVE SC25SP that meets the requirements of this specification and the ESCC Generic Specification.

1.8 MATERIALS AND FINISHES

Materials and finishes shall be as follows.

1.8.1 Connectors

The materials and finishes applicable to the various connectors shall be as follows:

- (a) Connector Code 01 to 11, 18: HDR AxoMach and SpaceFibre Connectors:
- Body Shell: Aluminium alloy, gold plated 2.54µm minimum over nickel underplate 25µm minimum.
 - Centre Contact: Copper alloy, gold plated 1.27µm minimum over nickel underplate 1.27µm minimum.
Note: measurements of plating thickness shall be made at 1.5mm from the engagement end.
 - Male plug connector front face, and connector to backshell interface EMI seals: Conductive silicone-base rubber.
 - Insert (insulator): PTFE.
 - Locking devices: Passivated stainless steel
 - Sleeve: Fluoropolymer; colour: black.
- (b) Connector Code 12 to 16: SMA Male and Female Connectors (ESCC Types):
As specified in ESCC Detail Specification Nos. [3402/001](#) and [3402/002](#), as applicable.
- (c) Connector Code 17: SMA Male Connector (Axon Type):
- Shell, Coupling Nut, Centre Contact: Beryllium copper, gold plated 2.54µm minimum over copper underplate 2.54µm minimum.
 - Insert (insulator): PTFE.
 - Gasket: Silicone rubber.
 - Ferrule: Brass, gold plated 2.54µm minimum over copper underplate 2.54µm minimum
 - Sleeve: Fluoropolymer; colour: black.

1.8.2 Cable

The materials and finishes applicable to the cable shall be as follows:

- Centre Conductor: Copper, silver plated 2µm minimum.
- Dielectric Core: Expanded PTFE.
- Shield 1: Copper tape, silver plated 2µm minimum.
- Separating Tape: Polyimide.
- Shield 2: Copper braid, silver plated 2µm minimum.
- Outer Jacket: Perfluoroalkoxy (PFA); colour: blue.

2 REQUIREMENTS

2.1 GENERAL

The complete requirements for procurement of the components specified herein are as stated in this specification and the ESCC Generic Specification. Permitted deviations from the Generic Specification, applicable to this specification only, are listed below.

Permitted deviations from the Generic Specification and this Detail Specification, formally agreed with specific Manufacturers on the basis that the alternative requirements are equivalent to the ESCC requirement and do not affect the component's reliability, are listed in the appendices attached to this specification.

2.1.1 Deviations from the Generic Specification

2.1.1.1 *Deviations from Qualification Testing – Chart F4A*

- (a) Para 8.28, Mating Endurance: For Connector Codes 12 to 17, Mating Endurance shall be performed in accordance with Endurance as specified in ESCC Generic Specification No. [3402](#).
- (b) Para. 8.33, Destructive Physical Analysis: For Connector Code 00 (pigtailed), a solderability test shall be added to DPA in accordance with ESCC Generic Specification No. [3902](#), performed on the centre conductor and shields of the cables.

2.1.1.2 *Deviations from Periodic Testing – Chart F4B*

- (a) Para. 8.33, Destructive Physical Analysis: For Connector Code 00 (pigtailed), a solderability test shall be added to DPA in accordance with ESCC Generic Specification No. [3902](#), performed on the centre conductor and shields of the cables.

2.2 MARKING

The marking shall be in accordance with the requirements of ESCC Basic Specification No. [21700](#) and as follows.

The information to be marked on the component or its primary package shall be:

- (a) The ESCC qualified components symbol (for ESCC qualified components only).
- (b) The ESCC Component Number (see Para. 1.4.1).
- (c) Traceability information.

2.3 ENVIRONMENTAL AND MECHANICAL TESTS

The following requirements apply to tests performed on the connector (and contact) lot, the cable lot and the cable assembly lot, as specified in the ESCC Generic Specification:

- (a) Para. 8.2, Contact Capability: The following test requirements shall apply, for Connector Codes 01, 02, 03, 10 only:

	Pick-up Test	Drop Test
Weight (g)	14 ±10%	170 ±10%
Test Sleeve Inner Diameter (mm)	0.582 to 0.587	0.559 to 0.564
Insertion Depth (mm)	1.5 ±0.05	1.5 ±0.05

- (b) Para. 8.3, Engagement and Separation Forces: The following test requirements shall apply, for Connector Codes 01, 02, 03, 10 only:

	Minimum Diameter Test Sleeve Test	Maximum Diameter Test Sleeve Test
Engagement Force (N)	1.667 maximum	-
Separation Force (N)	-	0.14 minimum
Test Sleeve Inner Diameter (mm)	0.559 to 0.564	0.582 to 0.587
Insertion Depth (mm)	1.4 ±0.05	1.4 ±0.05

- (c) Para. 8.5, Plating Thickness: See Para. 1.8.1.
- (d) Para. 8.6, Magnetism Level: Not applicable.
- (e) Para. 8.8, Insulation Flaws (Spark Test):
- Applied voltage: 600Vrms
 - Frequency: 50 or 60Hz
- (f) Para. 8.12, Adhesion of Inner Conductor: 1N minimum.
- (g) Para. 8.13, Dielectric Strength of Jacket: Applicable to all cable assemblies.
- Test voltage: 1.5kVac
 - Frequency: 50 or 60Hz
- (h) Para. 8.14, Conductor Resistance: 100Ω/km maximum at T_{amb} = +20°C.
- (i) Para. 8.15, Capacitance: 90pf/m maximum.
- (j) Para. 8.16, Characteristic Impedance (each individual cable): 50 ±2Ω.
- (k) Para. 8.19, Coupling Proof Torque: See Para. 1.4.2.1, for Connector Codes 12 to 17 only.
- (l) Para. 8.23, Contact Height: See Para. 1.6.3, for Connector Codes 01 to 11, 18 only.
- (m) Para. 8.26, Cable Retention Force: 25N per cable.
- (n) Para. 8.29.1, Contact Retention (in Insert): 14.8N, for Connector Codes 4 to 9, 11 to 18 only.
- (o) Para. 8.29.2, Insert Retention (in Shell): 4N, for Connector Codes 01 to 11, 18 only.
- (p) Para. 8.34, Radiation: Applicable to all cable assemblies. Radiation dosage: 30Mrad.
- (q) Para. 8.35, Permanence of Marking: Applicable to all components with marking.
- (r) Para. 8.36, Mating and Unmating Forces:

Connector Code	Mating Force	Unmating Force	
	Max	Min	Max
01, 04, 07	5.6N	0.4N	5.6N
02, 05, 08, 10, 11, 18	11.2N	0.8N	11.2N
03, 06, 09	22.4N	1.6N	22.4N
12, 13, 14, 15, 16, 17	-	-	120N.cm

- (s) Para. 8.37, Crimp Contact Tensile Strength: Applicable to Connector Codes: 01 to 11, 18 only.

2.4 ROOM TEMPERATURE ELECTRICAL MEASUREMENTS

The measurements shall be performed at $T_{amb} = +22 \pm 3^{\circ}C$.

Characteristics	Symbols	Test Method and Conditions	Limits		Units
			Min	Max	
Dielectric Withstanding Voltage	DWV	ESCC No. 3409, Note 1	600	-	Vrms
Voltage Proof Leakage Current	I _{VPL}	Note 2	-	2	mA
Insulation Resistance	R _I	ESCC No. 3409, V = 500Vdc	5	-	GΩ
Conductor Resistance	R _C	ESCC No. 3409	-	110	mΩ/m
Shield Resistance	R _S	ESCC No. 3409	-	45 per cable	mΩ/m
Mated Shell Conductivity	R _M	ESCC No. 3409	-	5	mΩ
Uniformity of Characteristic Impedance	Z _C	ESCC No. 3409 Each pair of cables. tr ≤ 50ps Note 3	90	110	Ω
Intra-pair Skew	SK ₁	ESCC No. 3409, Data rate ≤ 10Gb/s Test each pair of cables Note 4 For HDR-HDR CA's; Note 5: - 20 For other CA's; Note 6: - 10			ps
Inter-pair Skew	SK ₂	ESCC No. 3409, Data rate ≤ 10Gb/s Notes 4, 7 For HDR-HDR CA's; Note 5: - 20 For other CA's; Note 6: - 10			ps
Mask Test	MT	ESCC No. 3409 Only for CA's with all HDR connectors with codes 10, 11, 18	See Note 8		
Jitter pp	Jpp	ESCC No. 3409, Notes 4, 9 For L ≤ 2.5m; Data rate ≤ 10Gb/s: - 20 For L ≤ 4m; Data rate ≤ 5Gb/s: - 30 For L ≤ 10m; Data rate ≤ 5Gb/s: - 170			ps
Jitter rms	Jrms	ESCC No. 3409, Notes 4, 9 For L ≤ 2.5m; Data rate ≤ 10Gb/s: - 5 For L ≤ 4m; Data rate ≤ 5Gb/s: - 5 For L ≤ 10m; Data rate ≤ 5Gb/s: - 30			ps
Near-end Crosstalk	N _{ext}	ESCC No. 3409, Note 7 f ≤ 10GHz: - -35 f ≤ 5GHz: - -45			dB

Characteristics	Symbols	Test Method and Conditions	Limits		Units
			Min	Max	
Far-end Crosstalk	F _{ext}	ESCC No. 3409, Note 7 f ≤ 10GHz: f ≤ 5GHz:	-	-35	dB
			-	-45	
Insertion Loss	IL _{CA}	ESCC No. 3409, f ≤ 10GHz	-	Note 10	dB

NOTES:

1. Test voltage shall be applied between centre contacts, and between each centre contact and both respective connector bodies in the cable assembly.
2. Measured during Dielectric Withstanding Voltage.
3. Read and record measurements shall be performed on a sample of 3 components from each lot with 0 failures allowed. Alternatively a 100% inspection may be performed.
4. Tested using a PRBS-7 pattern with 1Vpp differential amplitude.
5. For any cable assembly that has only two or more HDR connectors (i.e. at both ends of the cable assembly).
6. For any cable assembly that either has one HDR connector and two or more SMA connectors, has all SMA connectors, or has only one HDR connector (i.e. with pigtails).
7. Applicable to any cable assembly with one or more HDR connector with Connector Code: 02, 03, 05, 06, 08, 09, 10, 11, 18.
8. For cable assemblies with Connector Codes 10, 11, 18 the Eye-Pattern requirements of ECSS-E-ST-50-11 shall apply.
9. Not applicable to cable assemblies with Connector Code 00 (pigtail).
10. Insertion Loss limit shall be calculated as follows:

$$IL_{CA} = IL_{CONNECTOR-A} + IL_{CONNECTOR-B} + (IL_{CABLE} \times L)$$

where:

- IL_{CA} = total cable assembly insertion loss
- IL_{CONNECTOR-A}, IL_{CONNECTOR-B} = insertion loss for the connector types on side A and B
- IL_{CABLE} = cable insertion loss
- L = cable assembly length (in m)

IL_{CONNECTOR} and IL_{CABLE} shall be calculated as follows, where f = frequency (in GHz):

- For each Connector Code 01 to 11, 18: $IL_{CONNECTOR} = 0.2 \times f$
- For each Connector Code 12 to 16: $IL_{CONNECTOR} = 0.03 \times \sqrt{f}$
- $IL_{CABLE} = (0.63 \times \sqrt{f}) + (0.017 \times f)$

2.5 INTERMEDIATE AND END-POINT ELECTRICAL MEASUREMENTS

Unless otherwise specified, the measurements shall be performed at $T_{amb} = +22 \pm 3^{\circ}C$

Unless otherwise specified, test methods and test conditions shall be as per the corresponding test defined in Para. 2.4 Room Temperature Electrical Measurements.

Test Reference per ESCC No. 3409	Characteristics	Symbols	Limits		Units
			Min	Max	
Shielding Effectiveness	Shielding Effectiveness DC < f ≤ 3GHz: 3GHz < f < 10GHz: f = 10GHz:	SE	60 Note 1 40	- - -	dB
Cable Retention Force	Dielectric Withstanding Voltage Voltage Proof Leakage Current Insulation Resistance Conductor Resistance Shield Resistance Mated Shell Conductivity	DWV I _{VPL} R _I R _C R _S R _M	See Para. 2.4 See Para. 2.4 See Para. 2.4 See Para. 2.4 See Para. 2.4 See Para. 2.4		
Ageing	Dielectric Withstanding Voltage Voltage Proof Leakage Current Insulation Resistance Conductor Resistance Shield Resistance Mated Shell Conductivity Uniformity of Characteristic Impedance Intra-pair Skew Inter-pair Skew Mask Test Jitter rms Jitter pp Near-end Crosstalk Far-end Crosstalk Insertion Loss	DWV I _{VPL} R _I R _C R _S R _M Z _C SK ₁ SK ₂ MT J _{rms} J _{pp} N _{ext} F _{ext} IL _{CA}	See Para. 2.4 See Para. 2.4 See Para. 2.4 See Para. 2.4 See Para. 2.4 See Para. 2.4 See Para. 2.4 See Para. 2.4 See Para. 2.4 See Para. 2.4 See Para. 2.4 See Para. 2.4 See Para. 2.4 See Para. 2.4 See Para. 2.4 See Para. 2.4		

Test Reference per ESCC No. 3409	Characteristics	Symbols	Limits		Units
			Min	Max	
Mating Endurance Initial Measurement Final Measurement	Conductor Resistance	R _C	See Para. 2.4		
	Shield Resistance	R _S	See Para. 2.4		
	Mated Shell Conductivity	R _M	See Para. 2.4		
	Dielectric Withstanding Voltage	DWV	See Para. 2.4		
	Voltage Proof Leakage Current	I _{VPL}	See Para. 2.4		
	Insulation Resistance	R _I	See Para. 2.4		
	Conductor Resistance	R _C	See Para. 2.4		
	Shield Resistance	R _S	See Para. 2.4		
	Mated Shell Conductivity	R _M	See Para. 2.4		
	Uniformity of Characteristic Impedance	Z _C	See Para. 2.4		
	Intra-pair Skew	SK ₁	See Para. 2.4		
	Inter-pair Skew	SK ₂	See Para. 2.4		
	Mask Test	MT	See Para. 2.4		
	Jitter rms	J _{rms}	See Para. 2.4		
	Jitter pp	J _{pp}	See Para. 2.4		
	Near-end Crosstalk	N _{ext}	See Para. 2.4		
	Far-end Crosstalk	F _{ext}	See Para. 2.4		
Insertion Loss	IL _{CA}	See Para. 2.4			
Bending	Dielectric Withstanding Voltage	DWV	See Para. 2.4		
	Voltage Proof Leakage Current	I _{VPL}	See Para. 2.4		
	Insulation Resistance	R _I	See Para. 2.4		
	Conductor Resistance	R _C	See Para. 2.4		
	Shield Resistance	R _S	See Para. 2.4		
	Mated Shell Conductivity	R _M	See Para. 2.4		
	Uniformity of Characteristic Impedance	Z _C	See Para. 2.4		
	Intra-pair Skew	SK ₁	See Para. 2.4		
	Inter-pair Skew	SK ₂	See Para. 2.4		
	Mask Test	MT	See Para. 2.4		
	Jitter rms	J _{rms}	See Para. 2.4		
	Jitter pp	J _{pp}	See Para. 2.4		
	Insertion Loss	IL _{CA}	See Para. 2.4		
	Shielding Effectiveness (ref. Para. 2.5)	SE	60	-	

Test Reference per ESCC No. 3409	Characteristics	Symbols	Limits		Units
			Min	Max	
Random Vibration During Testing Final Measurement	Electrical Continuity Dielectric Withstanding Voltage Voltage Proof Leakage Current Insulation Resistance Conductor Resistance Shield Resistance Mated Shell Conductivity	- DWV I _{VPL} R _I R _C R _S R _M	No discontinuities > 1µs See Para. 2.4 See Para. 2.4 See Para. 2.4 See Para. 2.4 See Para. 2.4 See Para. 2.4		
Sine Vibration	Dielectric Withstanding Voltage Voltage Proof Leakage Current Insulation Resistance Conductor Resistance Shield Resistance Mated Shell Conductivity	DWV I _{VPL} R _I R _C R _S R _M	See Para. 2.4 See Para. 2.4 See Para. 2.4 See Para. 2.4 See Para. 2.4 See Para. 2.4		
Temperature Cycling	Dielectric Withstanding Voltage Voltage Proof Leakage Current Insulation Resistance Conductor Resistance Shield Resistance Mated Shell Conductivity Uniformity of Characteristic Impedance Intra-pair Skew Inter-pair Skew Mask Test Jitter rms Jitter pp Near-end Crosstalk Far-end Crosstalk Insertion Loss	DWV I _{VPL} R _I R _C R _S R _M Z _C SK ₁ SK ₂ MT J _{rms} J _{pp} N _{ext} F _{ext} IL _{CA}	See Para. 2.4 See Para. 2.4 See Para. 2.4 See Para. 2.4 See Para. 2.4 See Para. 2.4 See Para. 2.4 See Para. 2.4 See Para. 2.4 See Para. 2.4 See Para. 2.4 See Para. 2.4 See Para. 2.4 See Para. 2.4 See Para. 2.4		
Thermal Stability and Skew During Testing (at each temperature step)	Intra-pair Skew Inter-pair Skew	SK ₁ SK ₂	- -	Note 2 Note 2	

Test Reference per ESCC No. 3409	Characteristics	Symbols	Limits		Units
			Min	Max	
Electrical Measurements at Room, High and Low Temperatures	At room temperature: $T_{amb} = +22 \pm 3^{\circ}\text{C}$				
	Dielectric Withstanding Voltage	DWV	See Para. 2.4		
	Voltage Proof Leakage Current	I_{VPL}	See Para. 2.4		
	Mask Test	MT	See Para. 2.4		
	Jitter rms	Jrms	See Para. 2.4		
	Jitter pp	Jpp	See Para. 2.4		
	Insertion Loss	IL_{CA}	See Para. 2.4		
	At high temperature: $T_{amb} = +125 (+0 -5)^{\circ}\text{C}$				
	Dielectric Withstanding Voltage	DWV	See Para. 2.4		
	Voltage Proof Leakage Current	I_{VPL}	See Para. 2.4		
	Mask Test	MT	See Para. 2.4		
	Jitter rms	Jrms	-	Note 3	
	Jitter pp	Jpp	-	Note 3	
	Insertion Loss	IL_{CA}	-	Note 4	
	At low temperature: $T_{amb} = -55 (+5 -0)^{\circ}\text{C}$				
	Dielectric Withstanding Voltage	DWV	See Para. 2.4		
	Voltage Proof Leakage Current	I_{VPL}	See Para. 2.4		
	Mask Test	MT	See Para. 2.4		
	Jitter rms	Jrms	See Para. 2.4		
	Jitter pp	Jpp	See Para. 2.4		
	Insertion Loss	IL_{CA}	-	Note 4	

Test Reference per ESCC No. 3409	Characteristics	Symbols	Limits		Units
			Min	Max	
Radiation Initial Measurement	Dielectric Withstanding Voltage	DWV	See Para. 2.4		
	Voltage Proof Leakage Current	I _{VPL}	See Para. 2.4		
	Insulation Resistance	R _I	See Para. 2.4		
	Uniformity of Characteristic Impedance	Z _C	See Para. 2.4		
	Insertion Loss	IL _{CA}	See Para. 2.4		
Final Measurement	Dielectric Withstanding Voltage	DWV	See Para. 2.4		
	Voltage Proof Leakage Current	I _{VPL}	See Para. 2.4		
	Insulation Resistance	R _I	See Para. 2.4		
	Uniformity of Characteristic Impedance	Z _C	See Para. 2.4		
	Insertion Loss	IL _{CA}	See Para. 2.4		

NOTES:

- For $f > 3\text{GHz}$, minimum SE is decreased linearly from 60dB at 3GHz to 40dB at 10GHz.
- 125% of the limit given in Para. 2.4, at all test temperatures.
- 133% of the limit given in Para. 2.4.
- Insertion Loss limits at high and low temperatures shall be calculated using the Insertion Loss measurement at room temperature and the applicable test temperature (T) as follows:

$$IL(at\ T) = 1.2 \times IL(at\ 22^{\circ}C) \times (1 + (T - 22) \times 0.002)$$

APPENDIX A
AGREED DEVIATIONS FOR AXON CABLE (F)

Items Affected	Description of Deviations
Para. 2.1.1 Deviations from the Generic Specification: Deviations from Production Control – Chart F2	Para. 8.10, Anthony and Brown Test: This test shall be performed only on the conductor prior to cable manufacturing (it shall not be performed on the finished cable).
Para. 2.1.1 Deviations from the Generic Specification: Deviations from Screening Tests – Chart F3	Para. 8.18, Coupling Proof Torque: This test shall only be performed on cable assemblies intended to be used to manufacture HDR cable assembly test vehicles used for Qualification Testing, Periodic Testing or Lot Validation Testing.
Para. 2.1.1.1 Deviations from the Generic Specification: Deviations from Qualification Testing – Chart F4A	Para. 8.37, Crimp Contact Tensile Strength: is not required to be repeated if it has already been performed as part of the Manufacturer's internal processing of the same lot, with equivalent sampling.