



**CONNECTORS, ELECTRICAL, FOR PRINTED
CIRCUIT BOARDS, NON-REMOVABLE SOLDER
AND WIRE-WRAP CONTACTS AND CONNECTOR
SAVERS**

BASED ON TYPE KMC

ESCC Detail Specification No. 3401/039

Issue 7	November 2024
---------	---------------



LEGAL DISCLAIMER AND COPYRIGHT

European Space Agency, Copyright © 2024. All rights reserved.

The European Space Agency disclaims any liability or responsibility, to any person or entity, with respect to any loss or damage caused, or alleged to be caused, directly or indirectly by the use and application of this ESCC publication.

This publication, without prior permission of the European Space Agency and provided it is not used for a commercial purpose, may be:

- copied in whole, in any medium, without alteration or modification.
- copied in part, in any medium, provided that the ESCC document identification, comprising the ESCC symbol, document number and document issue, is removed.

DOCUMENTATION CHANGE NOTICE

(Refer to <https://escies.org> for ESCC DCR content)

DCR No.	CHANGE DESCRIPTION
1689	Specification updated to incorporate changes per DCR.

TABLE OF CONTENTS

1	GENERAL	6
1.1	SCOPE	6
1.2	RANGE OF COMPONENTS	6
1.3	MAXIMUM RATINGS	6
1.4	PARAMETER DERATING INFORMATION	6
1.5	PHYSICAL DIMENSIONS	6
2	APPLICABLE DOCUMENTS	6
3	TERMS, DEFINITIONS, ABBREVIATIONS, SYMBOLS AND UNITS	6
4	REQUIREMENTS	33
4.1	GENERAL	33
4.2	DEVIATIONS FROM GENERIC SPECIFICATION	33
4.2.1	Deviations from Special In-process Controls	33
4.2.2	Deviations from Final Production Tests (Chart II)	33
4.2.3	Deviations from Burn-in and Electrical Measurements (Chart III)	33
4.2.4	Deviations from Qualification Tests (Chart IV)	33
4.2.5	Deviations from Lot Acceptance Tests (Chart V)	33
4.3	MECHANICAL REQUIREMENTS	34
4.3.1	Dimension Check	34
4.3.2	Weight	34
4.3.3	Contact Capability	34
4.3.4	Contact Retention (In Insert)	34
4.3.5	Mating and Unmating Forces	34
4.3.6	Insert Retention (In Shell)	34
4.3.7	Jackscrew Retention	34
4.3.8	Contact Insertion and Withdrawal Forces	34
4.3.9	Engagement and Separation Forces	35
4.3.10	Oversize Pin Exclusion	35
4.3.11	Probe Damage	35
4.3.12	Solderability	35
4.4	MATERIALS AND FINISHES	35
4.4.1	Shells	35
4.4.2	Inserts	35
4.4.3	Contacts	35
4.4.4	Contact Retaining Clip	35
4.4.5	Guiding and Locking Devices	36
4.4.6	Magnetism Level	36

4.5	MARKING	36
4.5.1	General	36
4.5.2	Contact Position	36
4.5.3	The ESCC Component Number	36
4.5.4	Characteristics	36
4.5.5	Traceability Information	37
4.6	ELECTRICAL MEASUREMENTS	37
4.6.1	Electrical Measurements at Room Temperature	37
4.6.2	Electrical Measurements at High and Low Temperatures (Table 3)	37
4.6.3	Circuits for Electrical Measurements (Figure 4)	37
4.7	BURN-IN AND ELECTRICAL MEASUREMENTS	38
4.8	ENVIRONMENTAL AND ENDURANCE TESTS (CHARTS IV AND V OF ESCC GENERIC SPECIFICATION NO. 3401)	38
4.8.1	Measurements and Inspections on Completion of Environmental Tests	38
4.8.2	Measurements and Inspections at Intermediate Points during Endurance Tests	38
4.8.3	Measurements and Inspections on Completion of Endurance Tests	38
4.8.4	Conditions for Operating Life Test (Part of Endurance Testing)	38
4.8.5	Electrical Circuit for Operating Life Test (Figure 5)	38
4.8.6	Conditions for High Temperature Storage Test (Part of Endurance Testing)	38

1 **GENERAL**

1.1 **SCOPE**

This specification details the ratings, physical and electrical characteristics, test and inspection data for Electrical Connectors for Printed Circuit Boards, Non-Removable Contacts, Wire-wrap, Solder and Saver, Based on Type KMC. It shall be read in conjunction with:

- ESCC Generic Specification No. [3401](#), Connectors, Electrical, Non-Filtered, Circular and Rectangular,

the requirements of which are supplemented herein.

1.2 **RANGE OF COMPONENTS**

The different configurations of the connectors and contacts specified herein, guiding and locking devices, compatibilities between inserts and guiding devices and between inserts and locking devices are given in Table 1(a).

1.3 **MAXIMUM RATINGS**

The maximum ratings applicable to the connectors specified herein, which shall not be exceeded at any time during use or storage, are scheduled in Table 1(b).

1.4 **PARAMETER DERATING INFORMATION**

The applicable derating information for the connectors specified herein is shown in Figure 1.

1.5 **PHYSICAL DIMENSIONS**

The physical dimensions of the connectors, plugs and receptacles, guiding and locking devices specified herein, and the contact mounting configurations, are shown in Figures 2(a), 2(b) and 2(c).

2 **APPLICABLE DOCUMENTS**

The following documents form part of this specification and shall be read in conjunction with it:

- (a) ESCC Generic Specification No. [3401](#), Connectors, Electrical, Non-Filtered, Circular and Rectangular.

3 **TERMS, DEFINITIONS, ABBREVIATIONS, SYMBOLS AND UNITS**

For the purpose of this specification, the terms, definitions, abbreviations, symbols and units specified in ESCC Basic Specification No. [21300](#) shall apply.

TABLE 1(a) – RANGE OF COMPONENTS

INSERT SIZES

Insert	No. of Contacts	Max Weight (g)	Max Engagement Force (N)	Separation Force (N)	
				Min	Max
Receptacle and Connector Saver	26	9.8	18.2	3.12	18.2
	44	12.6	30.8	5.28	30.8
	62	15.5	43.4	7.44	43.4
	80	18.4	56	9.6	56
	98	21	68.6	11.76	68.6
	144	30	100.8	17.28	100.8
Plug	26	8.2	18.2	3.12	18.2
	44	11.6	30.8	5.28	30.8
	62	14.9	43.4	7.44	43.4
	80	18.2	56	9.6	56
	98	21.4	68.6	11.76	68.6
	144	31.6	100.8	17.28	100.8

CONTACT TYPES

Contact Codes	Contact Types	Accepted Wire Size (AWG)
10	Solder, 90° for PCB	-
30	Solder, straight for PCB	-
31	Solder, straight long for PCB	-
40	Solder pot	28
50	Wire-wrap, 2 wrapping levels	28 - 30
51	Wire-wrap, 3 wrapping levels	28 - 30
91	Contact for connector saver	-

INTERMATEABILITY CHART, INSERTS AND GUIDING DEVICES

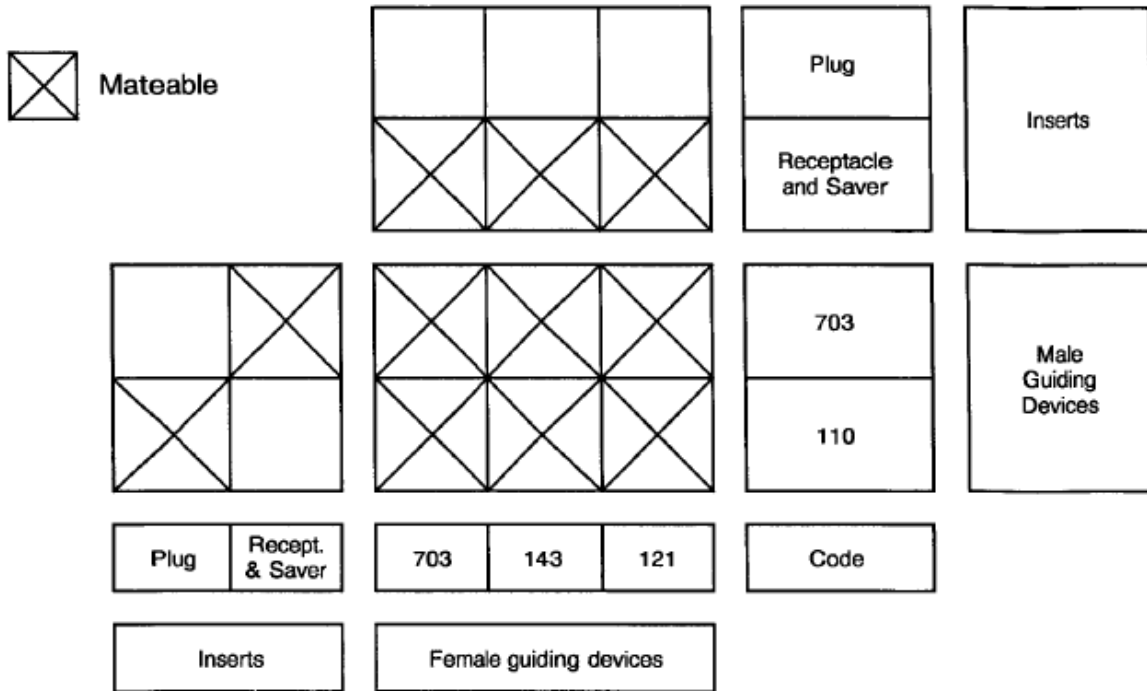

INTERMATEABILITY CHART, INSERTS AND LOCKING DEVICES

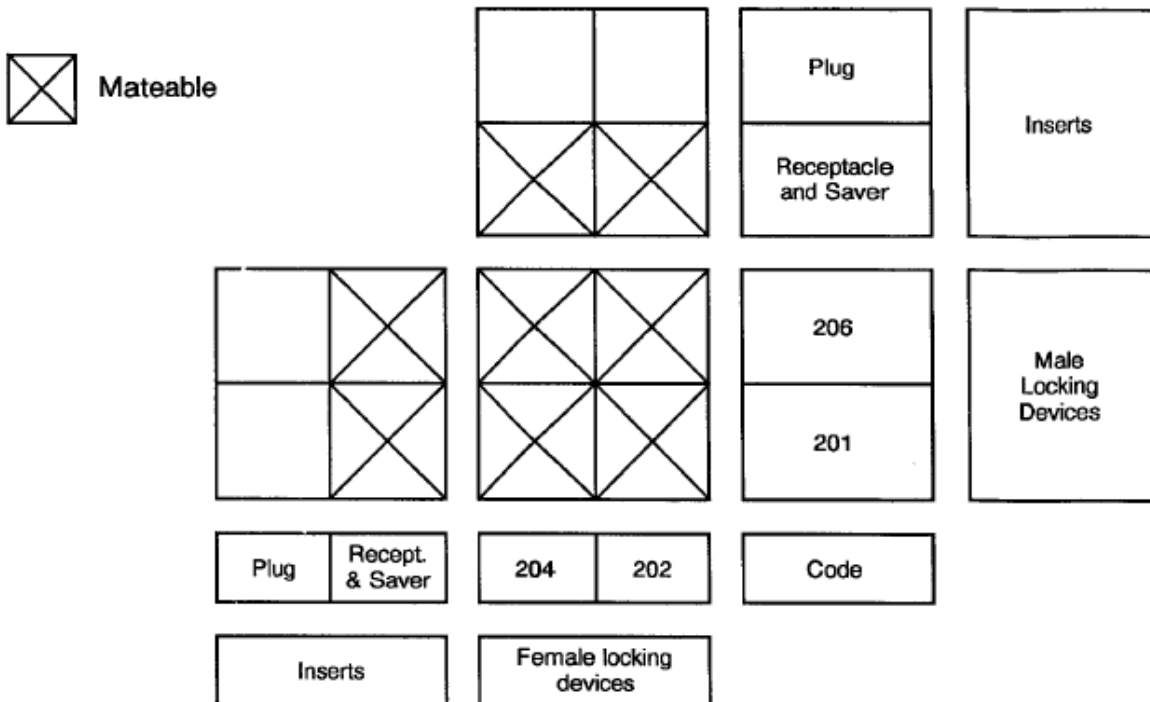

TABLE 1(b) – MAXIMUM RATINGS

No.	Characteristic	Symbol	Maximum Rating	Unit	Remarks
1	Working Voltage Sea Level	V	200	Vrms	Note 1
2	Rated Current	I_R	2	A	
3	Operating Temperature Range	T_{op}	-55 to +125	°C	T_{amb}
4	Storage Temperature Range	T_{stg}	-55 to +125	°C	
5	Soldering Temperature	T_{sol}	+260	°C	Note 2

NOTES:

1. Between contacts.
2. Duration 10 seconds minimum and the same contact shall not be resoldered until 3 minutes have elapsed.

FIGURE 1 – PARAMETER DERATING INFORMATION

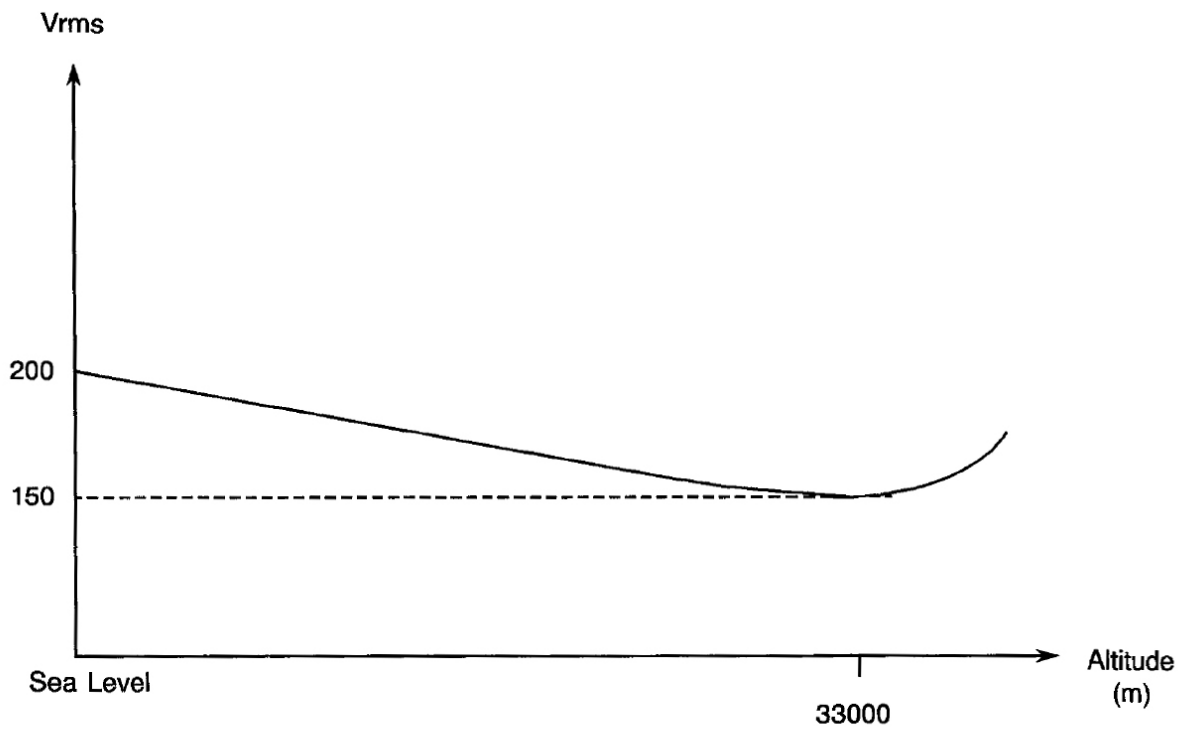

Working Voltage versus Altitude

FIGURE 2 – PHYSICAL DIMENSIONS

FIGURE 2(a) – INSERTS: PLUGS, RECEPTACLES AND SAVERS
RECEPTACLE, 3 ROWS, 26 CONTACTS

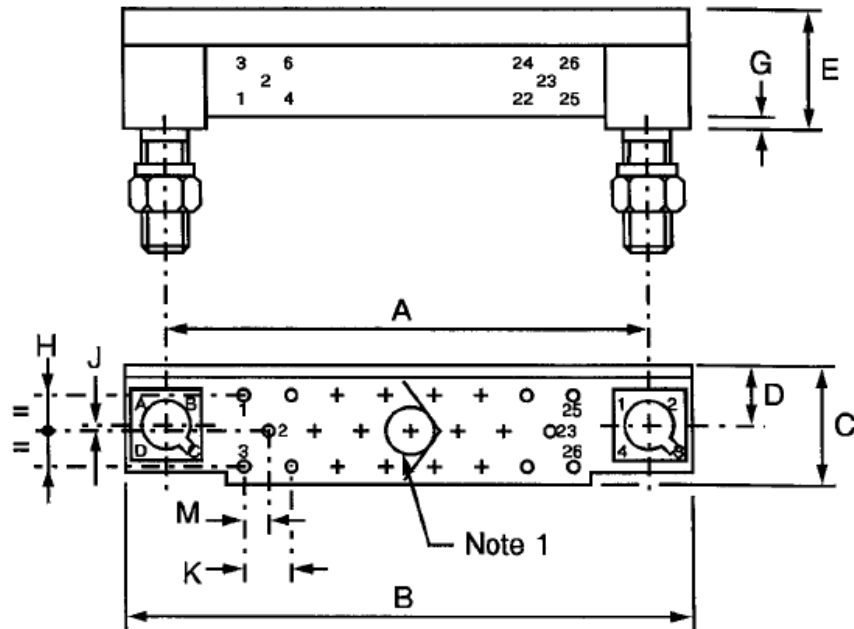

Symbol	Millimetres	
	Min	Max
A	30.43	30.53
B	38.1	38.5
C	6.6	7
D	3	3.1
E	7.75	8.05
G	0.25	0.36
H	3.76	3.86
J	0.26	0.36
K	2.39	2.69
M	1.12	1.42

NOTES:

1. Screw $\varnothing 2.25\text{mm}$ at contact location No. 11, Torque 2.2N.cm.
2. Orientation of labelling of contacts and guiding devices is not a true representation.
3. The front of the insert shall be marked with the minimum marking shown. The top of the insert shall be marked with every contact location.

RECEPTACLE, 3 ROWS, 44 CONTACTS

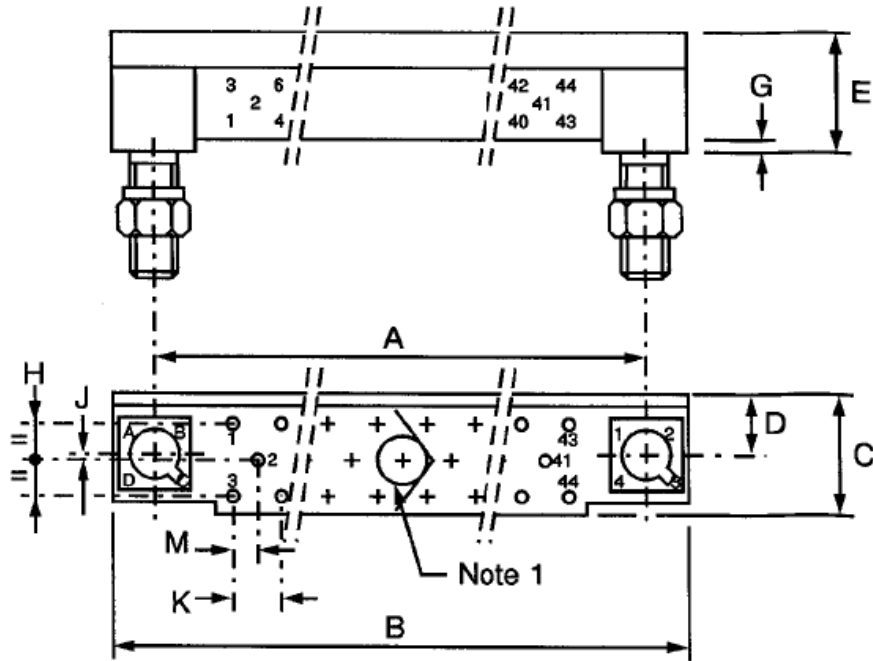

Symbol	Millimetres	
	Min	Max
A	45.67	45.77
B	53.3	53.7
C	6.6	7
D	3	3.1
E	7.75	8.05
G	0.25	0.36
H	3.76	3.86
J	0.26	0.36
K	2.39	2.69
M	1.12	1.42

NOTES:

1. Screw $\varnothing 2.25\text{mm}$ at contact location No. 20, Torque 2.2N.cm.
2. Orientation of labelling of contacts and guiding devices is not a true representation.
3. The front of the insert shall be marked with the minimum marking shown. The top of the insert shall be marked with every contact location.

RECEPTACLE, 3 ROWS, 62 CONTACTS

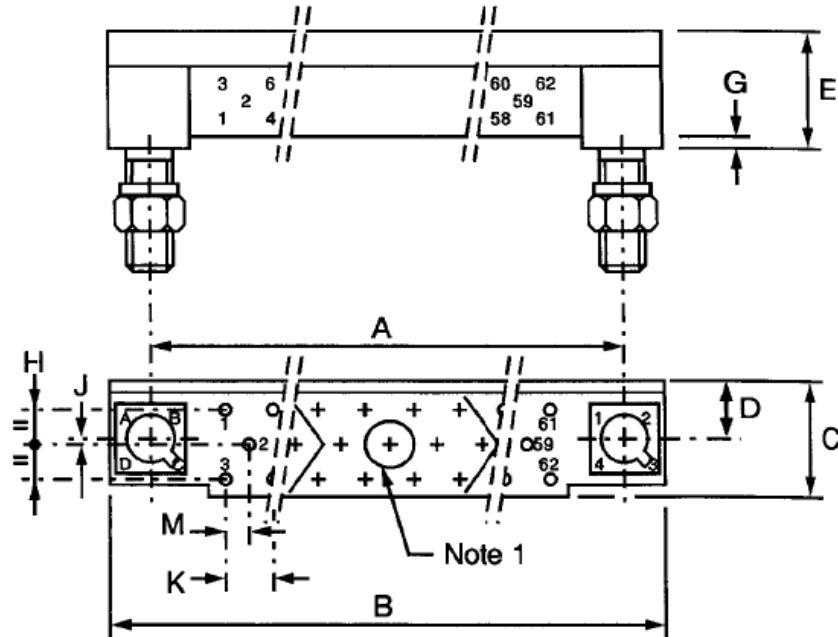

Symbol	Millimetres	
	Min	Max
A	60.91	61.01
B	68.6	69
C	6.6	7
D	3	3.1
E	7.75	8.05
G	0.25	0.36
H	3.76	3.86
J	0.26	0.36
K	2.39	2.69
M	1.12	1.42

NOTES:

1. Screw $\varnothing 2.25\text{mm}$ at contact location No. 29, Torque 2.2N.cm.
2. Orientation of labelling of contacts and guiding devices is not a true representation.
3. The front of the insert shall be marked with the minimum marking shown. The top of the insert shall be marked with every contact location.

RECEPTACLE, 3 ROWS, 80 CONTACTS

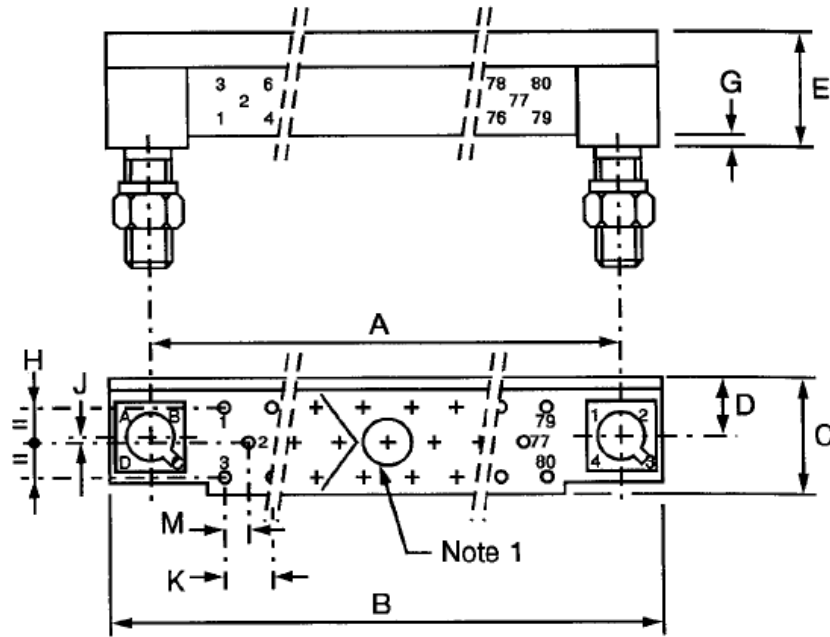

Symbol	Millimetres	
	Min	Max
A	76.15	76.25
B	83.8	84.2
C	6.6	7
D	3	3.1
E	7.75	8.05
G	0.25	0.36
H	3.76	3.86
J	0.26	0.36
K	2.39	2.69
M	1.12	1.42

NOTES:

1. Screw Ø2.25mm at contact location No. 38, Torque 2.2N.cm.
2. Orientation of labelling of contacts and guiding devices is not a true representation.
3. The front of the insert shall be marked with the minimum marking shown. The top of the insert shall be marked with every contact location.

RECEPTACLE, 3 ROWS, 98 CONTACTS

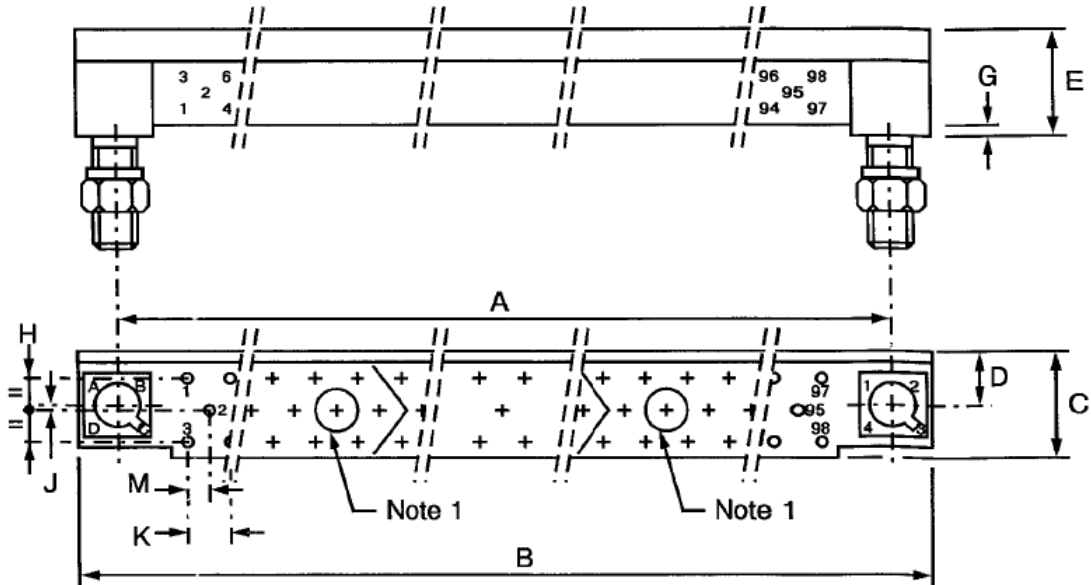

Symbol	Millimetres	
	Min	Max
A	91.39	91.49
B	99.1	99.5
C	6.6	7
D	3	3.1
E	7.75	8.05
G	0.25	0.36
H	3.76	3.86
J	0.26	0.36
K	2.39	2.69
M	1.12	1.42

NOTES:

1. Screw $\varnothing 2.25\text{mm}$ at contact location Nos. 32 and 65, Torque 2.2N.cm.
2. Orientation of labelling of contacts and guiding devices is not a true representation.
3. The front of the insert shall be marked with the minimum marking shown. The top of the insert shall be marked with every contact location.

RECEPTACLE, 3 ROWS, 144 CONTACTS

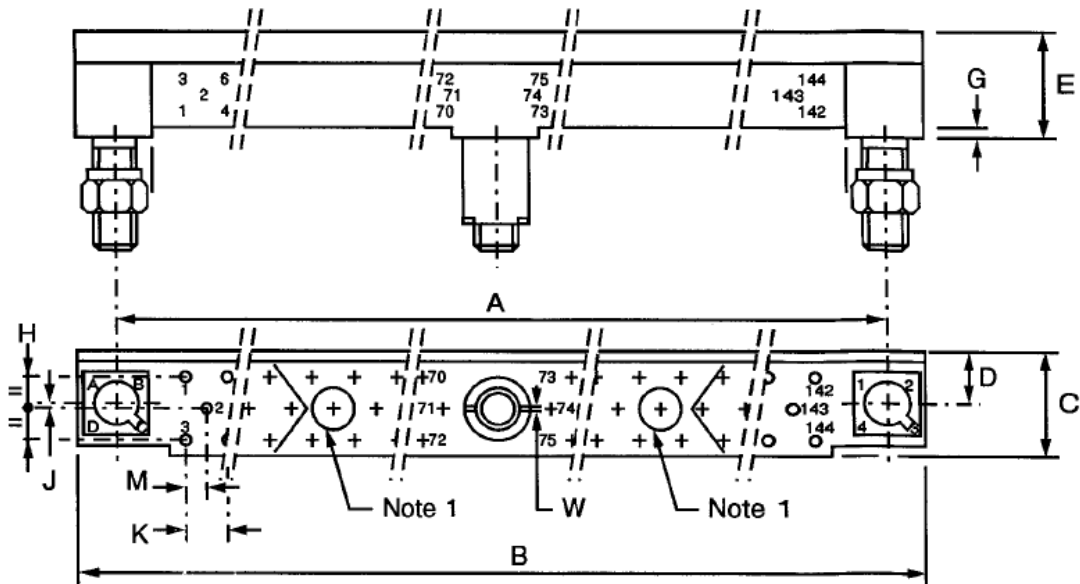

Symbol	Millimetres	
	Min	Max
A	137.11	137.21
B	144.8	145.2
C	6.6	7
D	3	3.1
E	7.75	8.05
G	0.25	0.36
H	3.76	3.86
J	0.26	0.36
K	2.39	2.69
M	1.12	1.42
W	0.85	1.15

NOTES:

1. Screw $\varnothing 2.25\text{mm}$ at contact location Nos. 38 and 107, Torque 2.2N.cm.
2. Orientation of labelling of contacts and guiding devices is not a true representation.
3. The front of the insert shall be marked with the minimum marking shown. The top of the insert shall be marked with every contact location.

PLUG, 3 ROWS, 26 CONTACTS

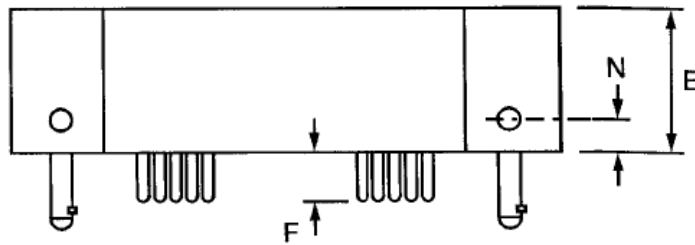
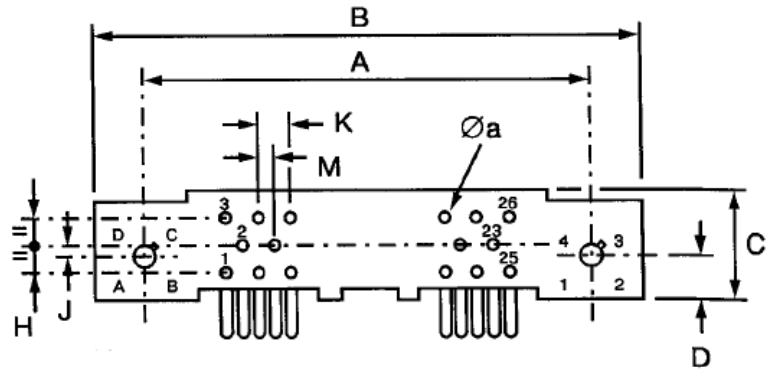

Symbol	Millimetres	
	Min	Max
Øa	0.48	0.5
A	30.43	30.53
B	38.1	38.5
C	6.6	7
D	3.1	3.2
E	11.65	11.95
F	4.2	5.2
H	3.76	3.86
J	0.26	0.36
K	2.39	2.69
M	1.12	1.42
N	3.8	4

NOTES:

1. Orientation of labelling of contacts and guiding devices is not a true representation.
2. The front of the insert shall be marked with the minimum marking shown.

PLUG, 3 ROWS, 44 CONTACTS

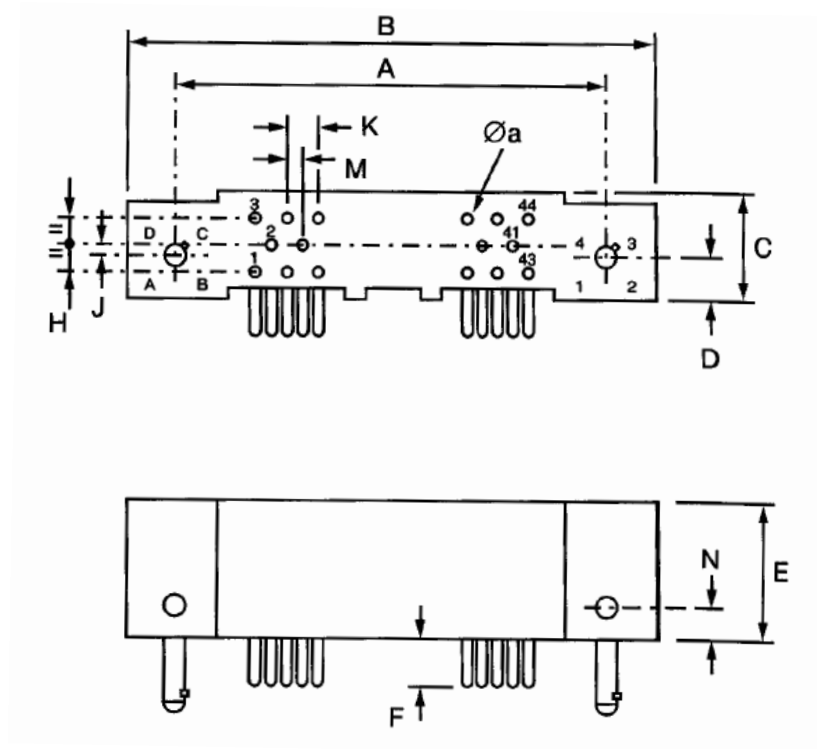

Symbol	Millimetres	
	Min	Max
Øa	0.48	0.5
A	45.67	45.77
B	53.3	53.7
C	6.6	7
D	3.1	3.2
E	11.65	11.95
F	4.2	5.2
H	3.76	3.86
J	0.26	0.36
K	2.39	2.69
M	1.12	1.42
N	3.8	4

NOTES:

1. Orientation of labelling of contacts and guiding devices is not a true representation.
2. The front of the insert shall be marked with the minimum marking shown.

PLUG, 3 ROWS, 62 CONTACTS

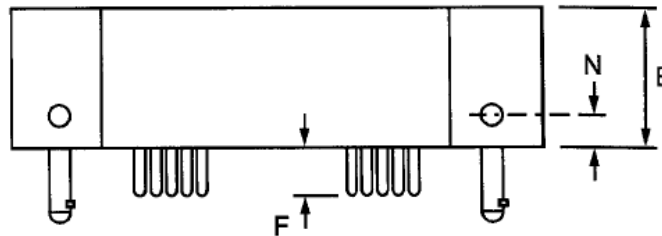
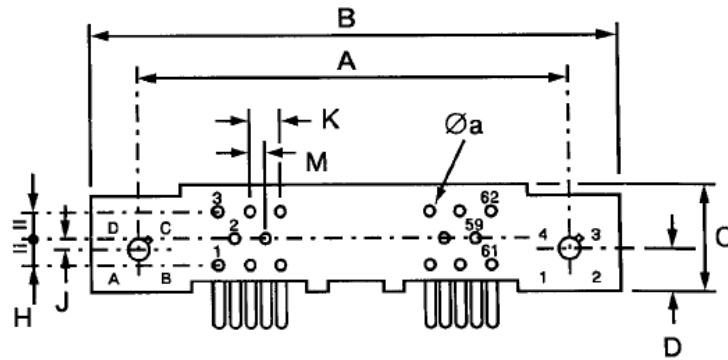

Symbol	Millimetres	
	Min	Max
$\varnothing a$	0.48	0.5
A	60.91	61.01
B	68.6	69
C	6.6	7
D	3.1	3.2
E	11.65	11.95
F	4.2	5.2
H	3.76	3.86
J	0.26	0.36
K	2.39	2.69
M	1.12	1.42

NOTES:

1. Orientation of labelling of contacts and guiding devices is not a true representation.
2. The front of the insert shall be marked with the minimum marking shown.

PLUG, 3 ROWS, 80 CONTACTS

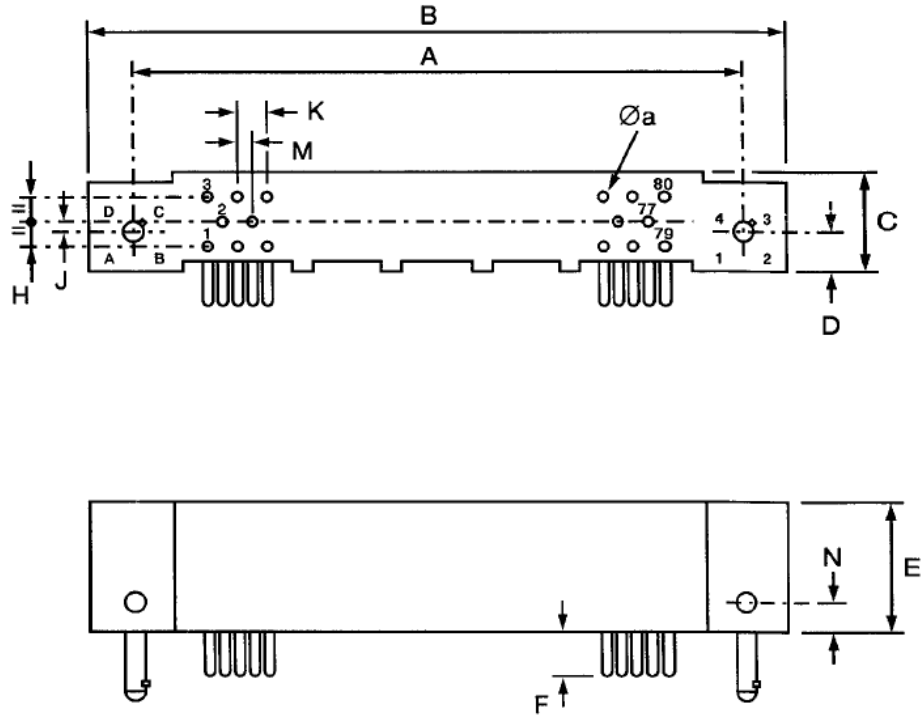

Symbol	Millimetres	
	Min	Max
Øa	0.48	0.5
A	76.15	76.25
B	83.8	84.2
C	6.6	7
D	3.1	3.2
E	11.65	11.95
F	4.2	5.2
H	3.76	3.86
J	0.26	0.36
K	2.39	2.69
M	1.12	1.42
N	3.8	4

NOTES:

1. Orientation of labelling of contacts and guiding devices is not a true representation.
2. The front of the insert shall be marked with the minimum marking shown.

PLUG, 3 ROWS, 98 CONTACTS

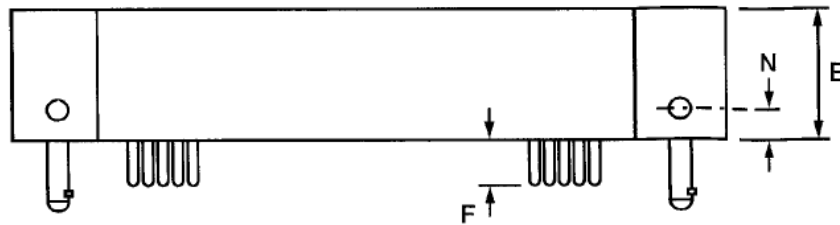
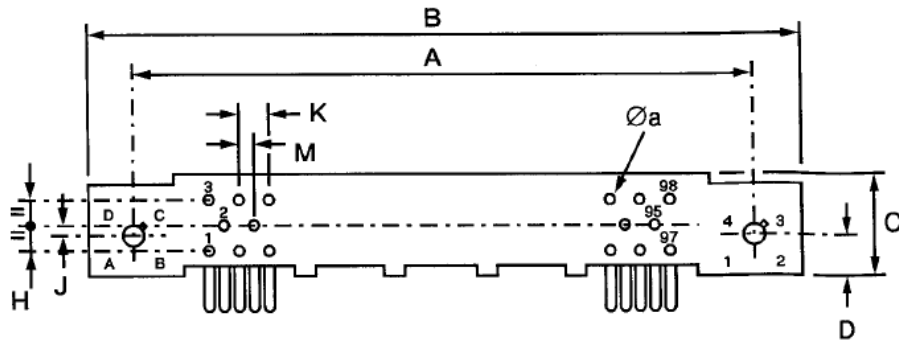

Symbol	Millimetres	
	Min	Max
Øa	0.48	0.5
A	91.39	91.49
B	99.1	99.5
C	6.6	7
D	3.1	3.2
E	11.65	11.95
F	4.2	5.2
H	3.76	3.86
J	0.26	0.36
K	2.39	2.69
M	1.12	1.42
N	3.8	4

NOTES:

1. Orientation of labelling of contacts and guiding devices is not a true representation.
2. The front of the insert shall be marked with the minimum marking shown.

PLUG, 3 ROWS, 144 CONTACTS

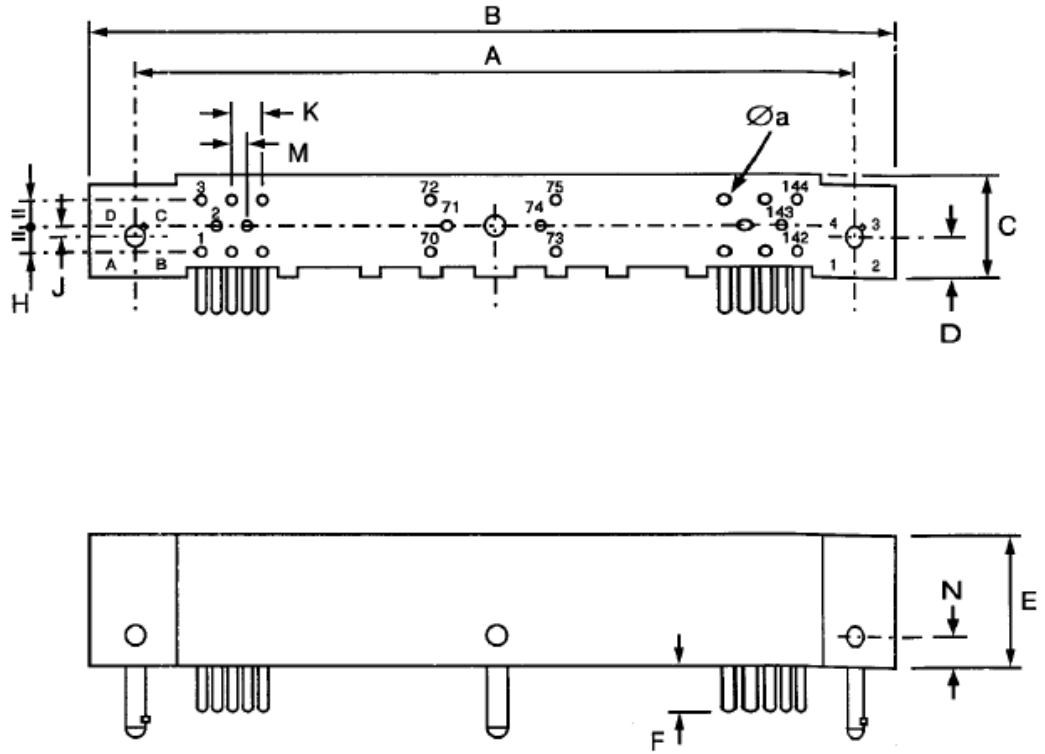

Symbol	Millimetres	
	Min	Max
Øa	0.48	0.5
A	137.11	137.21
B	144.8	145.2
C	6.6	7
D	3.1	3.2
E	11.65	11.95
F	4.2	5.2
H	3.76	3.86
J	0.26	0.36
K	2.39	2.69
M	1.12	1.42
N	3.8	4

NOTES:

1. Orientation of labelling of contacts and guiding devices is not a true representation.
2. The front of the insert shall be marked with the minimum marking shown.

CONNECTOR SAVER, 3 ROWS, 26 CONTACTS

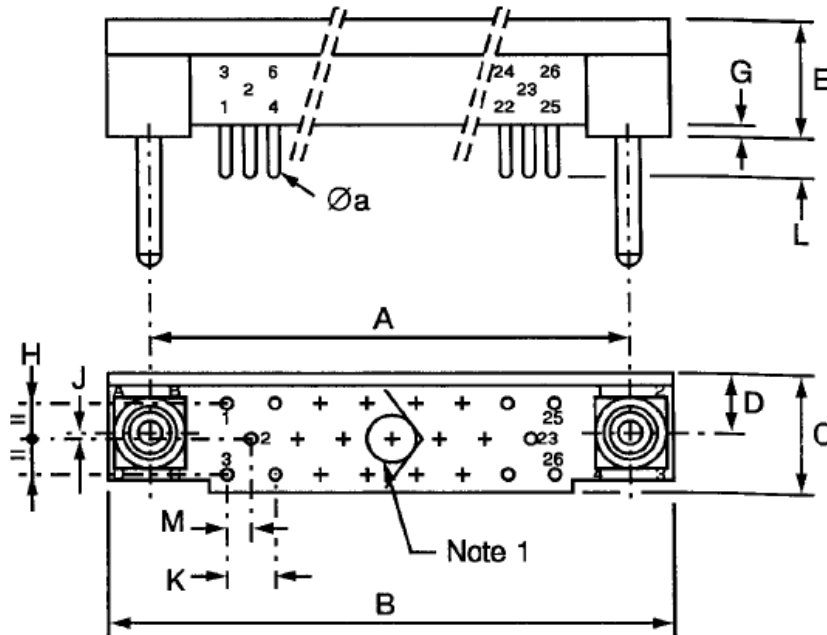

Symbol	Millimetres	
	Min	Max
$\varnothing a$	0.48	0.5
A	30.43	30.53
B	38.1	38.5
C	6.6	7
D	3	3.1
E	7.75	8.05
G	0.25	0.36
H	3.76	3.86
J	0.26	0.36
K	2.39	2.69
L	4.2	5.2
M	1.12	1.42

NOTES:

1. Screw $\varnothing 2.25\text{mm}$ at contact location No. 11, Torque 2.2N.cm.
2. Orientation of labelling of contacts and guiding devices is not a true representation.
3. The front of the insert shall be marked with the minimum marking shown. The top of the insert shall be marked with every contact location.

CONNECTOR SAVER, 3 ROWS, 44 CONTACTS

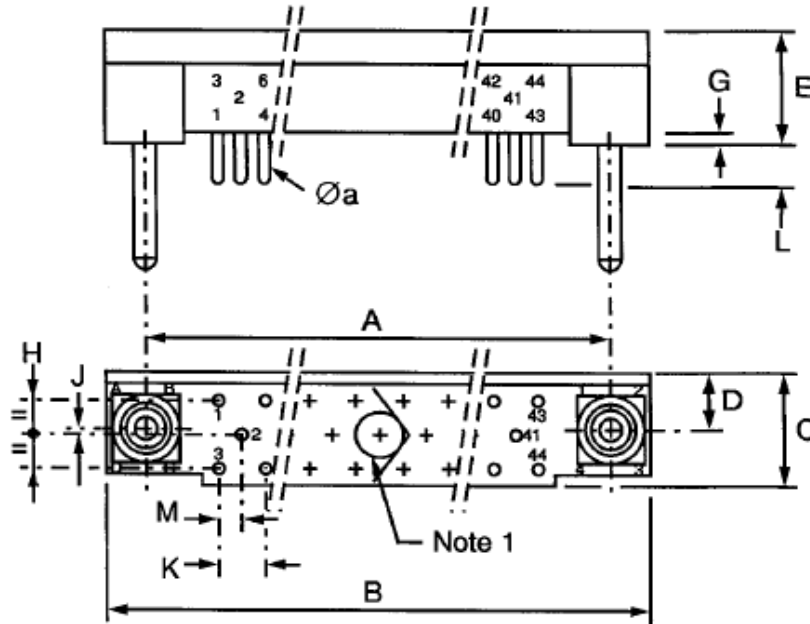

Symbol	Millimetres	
	Min	Max
$\varnothing a$	0.48	0.5
A	45.67	45.77
B	53.3	53.7
C	6.6	7
D	3	3.1
E	7.75	8.05
G	0.25	0.36
H	3.76	3.86
J	0.26	0.36
K	2.39	2.69
L	4.2	5.2
M	1.12	1.42

NOTES:

1. Screw $\varnothing 2.25\text{mm}$ at contact location No. 20, Torque 2.2N.cm.
2. Orientation of labelling of contacts and guiding devices is not a true representation.
3. The front of the insert shall be marked with the minimum marking shown. The top of the insert shall be marked with every contact location.

CONNECTOR SAVER, 3 ROWS, 62 CONTACTS

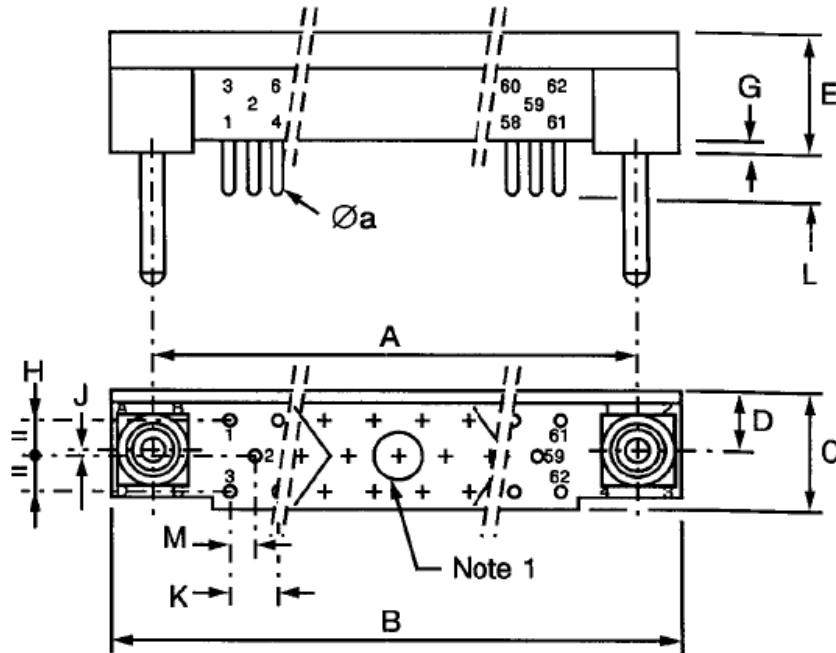

Symbol	Millimetres	
	Min	Max
$\varnothing a$	0.48	0.5
A	60.91	61.01
B	68.6	69
C	6.6	7
D	3	3.1
E	7.75	8.05
G	0.25	0.36
H	3.76	3.86
J	0.26	0.36
K	2.39	2.69
L	4.2	5.2
M	1.12	1.42

NOTES:

1. Screw $\varnothing 2.25\text{mm}$ at contact location No. 29, Torque 2.2N.cm.
2. Orientation of labelling of contacts and guiding devices is not a true representation.
3. The front of the insert shall be marked with the minimum marking shown. The top of the insert shall be marked with every contact location.

CONNECTOR SAVER, 3 ROWS, 80 CONTACTS

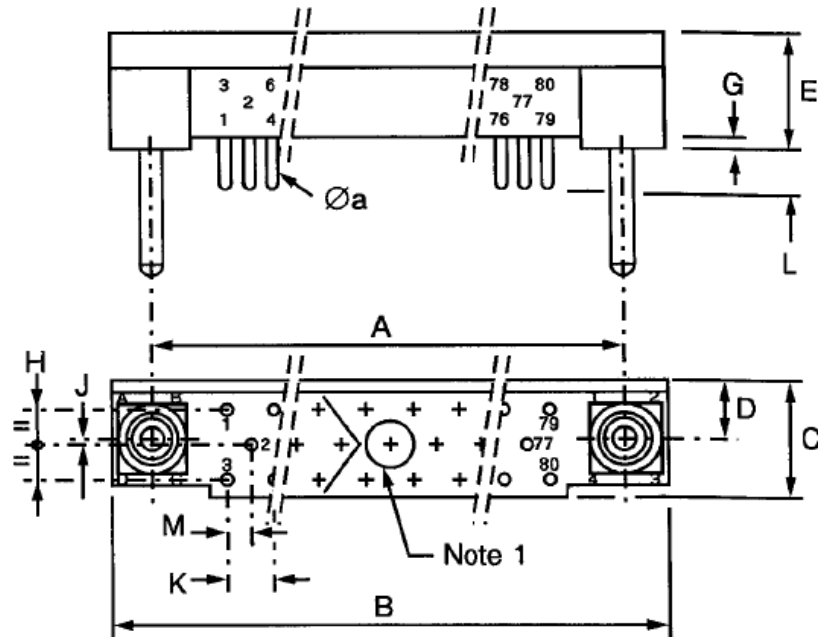

Symbol	Millimetres	
	Min	Max
Øa	0.48	0.5
A	76.15	76.25
B	83.8	84.2
C	6.6	7
D	3	3.1
E	7.75	8.05
G	0.25	0.36
H	3.76	3.86
J	0.26	0.36
K	2.39	2.69
L	4.2	5.2
M	1.12	1.42

NOTES:

1. Screw Ø2.25mm at contact location No. 38, Torque 2.2N.cm.
2. Orientation of labelling of contacts and guiding devices is not a true representation.
3. The front of the insert shall be marked with the minimum marking shown. The top of the insert shall be marked with every contact location.

CONNECTOR SAVER, 3 ROWS, 98 CONTACTS

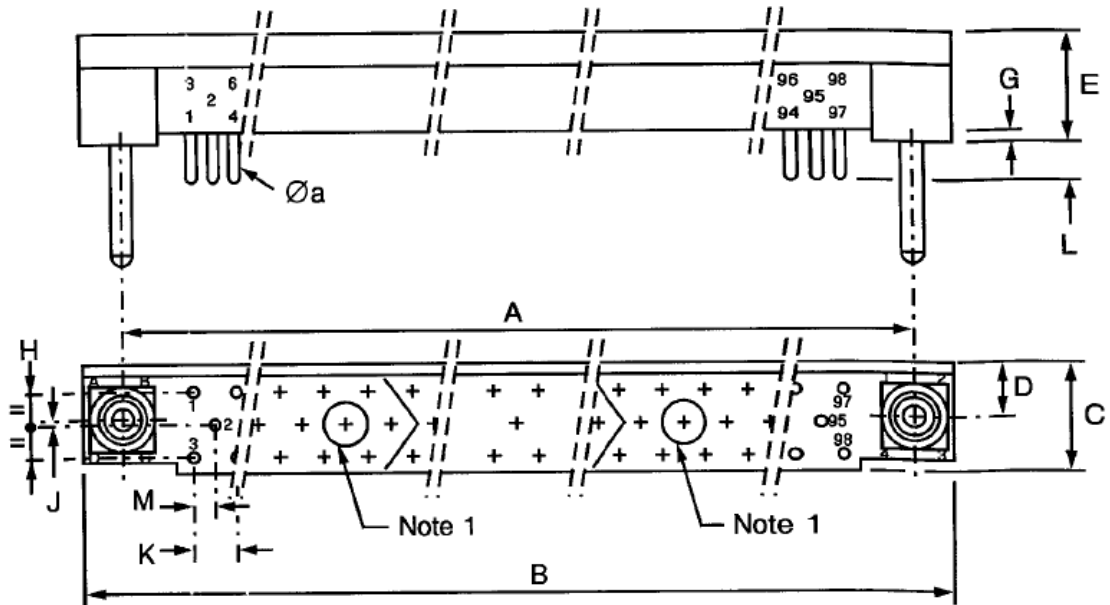

Symbol	Millimetres	
	Min	Max
$\varnothing a$	0.48	0.5
A	91.39	91.49
B	99.1	99.5
C	6.6	7
D	3	3.1
E	7.75	8.05
G	0.25	0.36
H	3.76	3.86
J	0.26	0.36
K	2.39	2.69
L	4.2	5.2
M	1.12	1.42

NOTES:

1. Screw $\varnothing 2.25\text{mm}$ at contact location Nos. 32 and 65, Torque 2.2N.cm.
2. Orientation of labelling of contacts and guiding devices is not a true representation.
3. The front of the insert shall be marked with the minimum marking shown. The top of the insert shall be marked with every contact location.

CONNECTOR SAVER, 3 ROWS, 144 CONTACTS

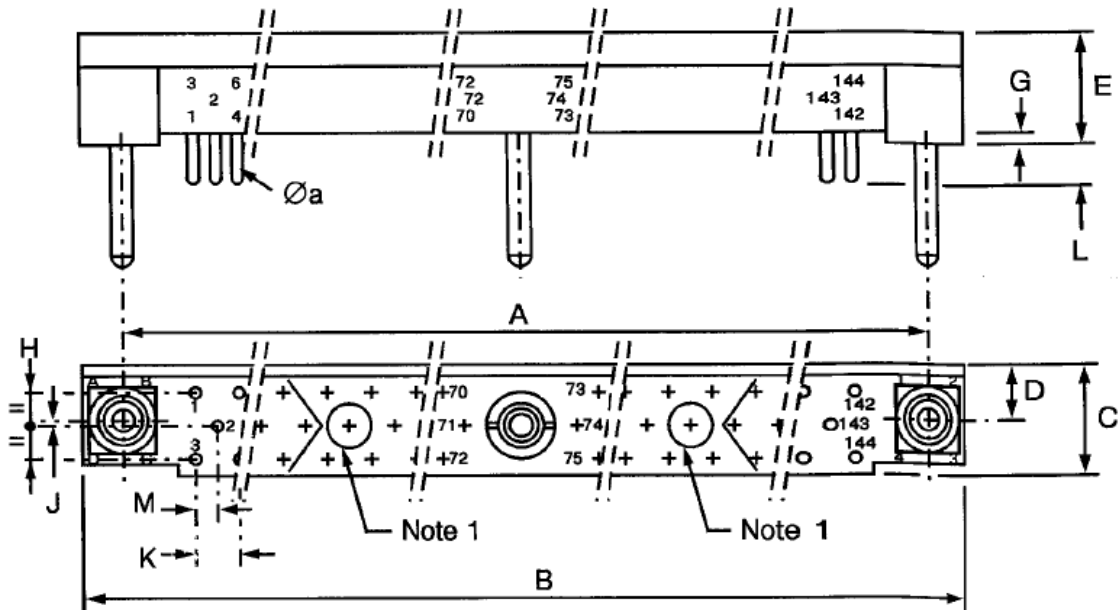

Symbol	Millimetres	
	Min	Max
Øa	0.48	0.5
A	137.11	137.21
B	144.8	145.2
C	6.6	7
D	3	3.1
E	7.75	8.05
G	0.25	0.36
H	3.76	3.86
J	0.26	0.36
K	2.39	2.69
L	4.2	5.2
M	1.12	1.42

NOTES:

1. Screw Ø2.25mm at contact location Nos. 38 and 107, Torque 2.2N.cm.
2. Orientation of labelling of contacts and guiding devices is not a true representation.
3. The front of the insert shall be marked with the minimum marking shown. The top of the insert shall be marked with every contact location.

FIGURE 2(b) – GUIDING AND LOCKING DEVICES

CODE 110

Symbol	Millimetres		Notes
	Min	Max	
A	-	1.6	1
B	2.34	2.74	
ØC	2.9	3	
D	6.4	7	

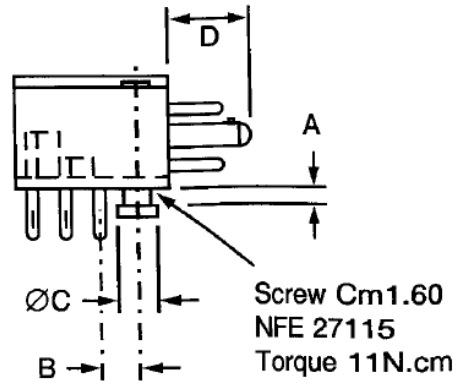

NOTES:

1. Allowable printed circuit board thickness.

CODE 121

Symbol	Millimetres		Notes
	Min	Max	
A	6.5	7.5	1
B	7	7.15	
ØC	1.98	2.03	
D	3.95	4.05	
E	M 2.5		
ØF	3.95	4.05	

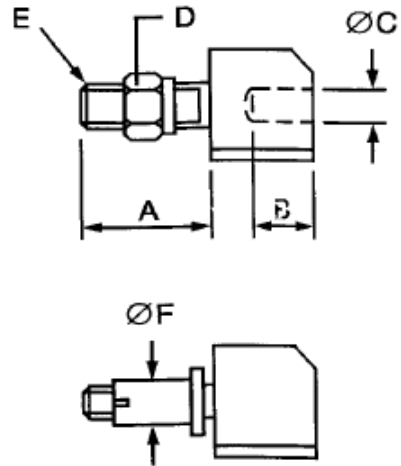

NOTES:

1. Across flats. Torque: 25N.cm.

CODE 143

Symbol	Millimetres		Notes
	Min	Max	
A	4.5	5.5	1
B	7	7.15	
ØC	1.98	2.03	
D	3.95	4.05	
E	M 2.5		
ØF	3.95	4.05	

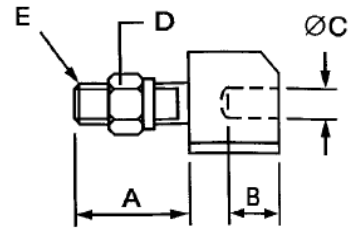

Centre guide for 144 contact connector

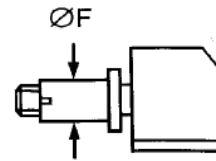

NOTES:

1. Across flats. Torque: 25N.cm.
2. Torque: 15N.cm.

CODE 201

Symbol	Millimetres		Notes
	Min	Max	
A	10.8	14.8	1
B	24.3	24.7	
ØC	M 1.6		2
D	5.4	5.6	

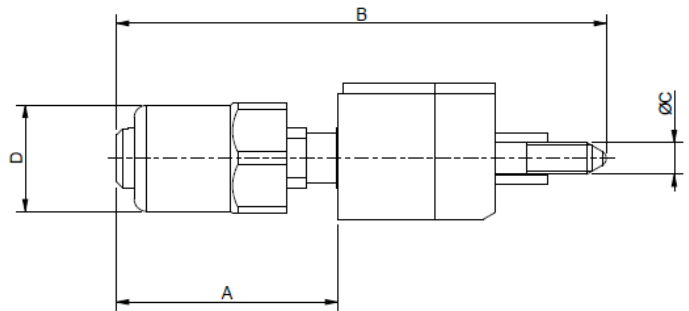

NOTES:

1. Max. dimension when unlocked.
2. Across flats. Torque: 25N.cm.

CODE 202

Symbol	Millimetres		Notes
	Min	Max	
A	6.5	7.5	1
B	2.4	2.8	
ØC	M 1.6		
D	3.95	4.05	
ØE	M 2.5		

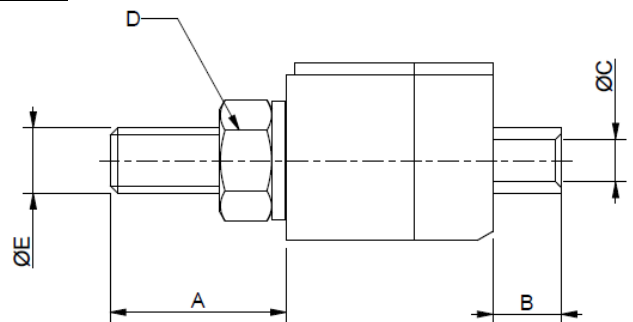

NOTES:

1. Across flats. Torque: 25N.cm.

CODE 204

Symbol	Millimetres		Notes	
	Min	Max		
A	6.5	7.5	1	
B	2.4	2.8		
ØC	M 1.6			
D	3.95	4.05		
ØE	M 2.5			
F	-	1.6		2
G	3.5	3.65		
H	3.8	4.2		

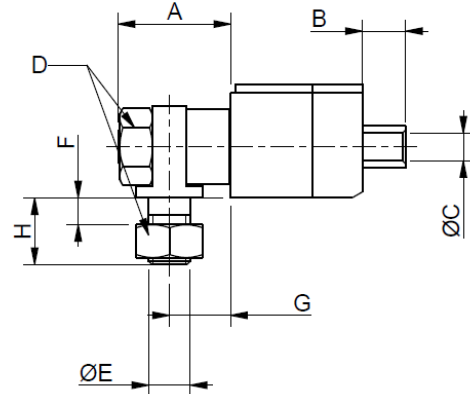

NOTES:

1. Across flats. Torque: 25N.cm.
2. Allowable printed circuit board thickness.

CODE 206

Symbol	Millimetres	
	Min	Ma.
A	4.6	5
B	18.05	18.35
ØC	M 1.6	
ØD	4.3	4.7

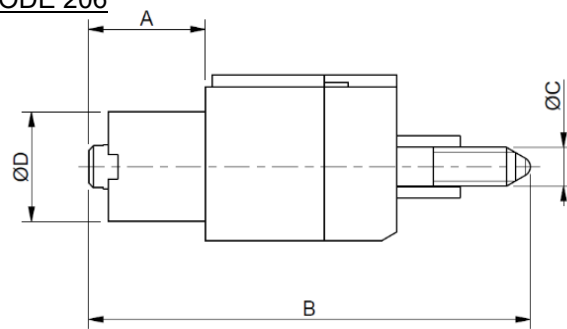

CODE 703

Symbol	Millimetres	
	Min	Max
A	6.4	7
B	7	7.15
ØC	2.57	2.63
ØD	1.75	1.8

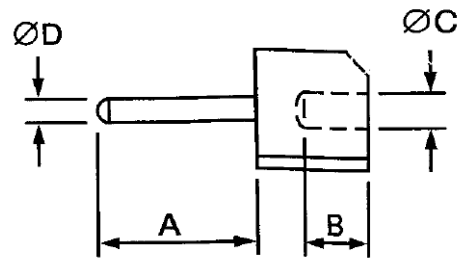
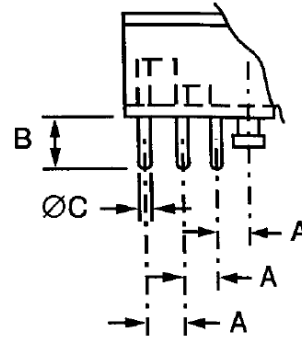

FIGURE 2(c) – CONTACT MOUNTING CONFIGURATIONS – VIEW OF REAR PART OF CONNECTOR

CODE 10

Symbol	Millimetres	
	Min	Max
A	2.34	2.74
B	2.6	3.2
ØC	0.46	0.54



CODE 30

Symbol	Millimetres	
	Min	Max
A	2.39	2.69
B	4	5
ØC	0.46	0.54

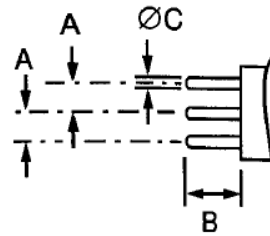

CODE 31

Symbol	Millimetres	
	Min	Max
A	2.39	2.69
B	5.1	6.1
ØC	0.46	0.54

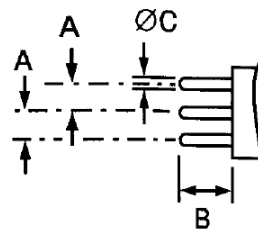

CODE 40

Symbol	Millimetres	
	Min	Max
A	2	3
B	3.7	4.7
ØC	0.55	0.59
D	1.4	2

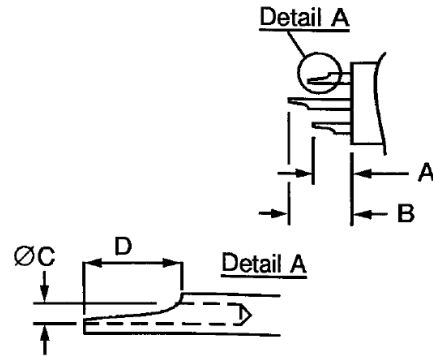

CODE 50

Symbol	Millimetres	
	Min	Max
A	2.39	2.69
B	9.2	11
C	0.6 Nom.	
D	0.76	0.864

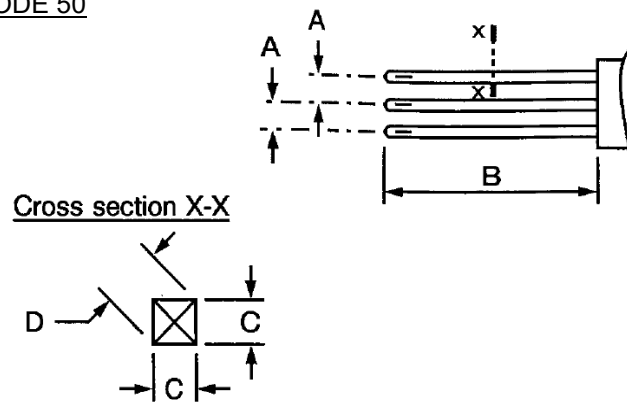

CODE 51

Symbol	Millimetres	
	Min	Max
A	2.39	2.69
B	13.2	15
C	0.6 Nom.	
D	0.76	0.864

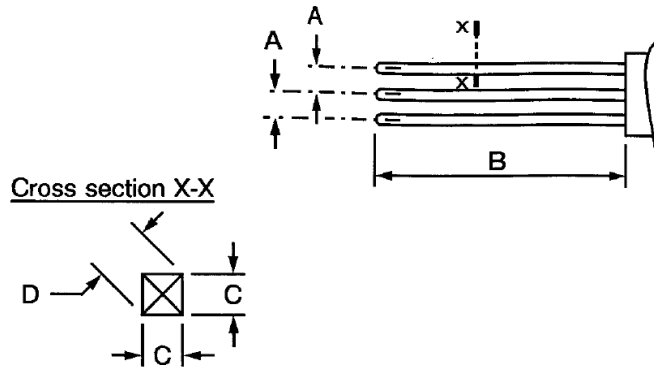

4 REQUIREMENTS

4.1 GENERAL

The complete requirements for procurement of the connectors specified herein are stated in this specification and ESCC Generic Specification No. 3401. Deviations from the Generic Specification, applicable to this specification only, are listed in Para. 4.2.

Deviations from the applicable Generic Specification and this Detail Specification, formally agreed with specific Manufacturers on the basis that the alternative requirements are equivalent to the ESCC requirements and do not affect the components' reliability, are listed in the appendices attached to this specification.

4.2 DEVIATIONS FROM GENERIC SPECIFICATION

4.2.1 Deviations from Special In-process Controls

None.

4.2.2 Deviations from Final Production Tests (Chart II)

- (a) Para. 9.1.1.4, Mated Shell Conductivity: Not applicable.
- (b) Para. 9.4, Contact Capability: Sampling in accordance with Para. 9.6 of ESCC No. 3401.
- (c) Para. 9.5, Magnetism Level: Not applicable.
- (d) Para. 9.9, Seal Test: Not applicable.

4.2.3 Deviations from Burn-in and Electrical Measurements (Chart III)

Chart III is not applicable.

4.2.4 Deviations from Qualification Tests (Chart IV)

- (a) Para. 9.1.1.4, Mated Shell Conductivity: Not applicable.
- (b) Para. 9.9, Seal Test: Not applicable.
- (c) Para. 9.17, Contact Retention: For solder 90° PCB contacts, the force applied to the engagement end of the contact shall be compression only.
- (d) Para. 9.22, Corrosion: Not applicable.
- (e) Para. 9.23, Insert Retention (in shell): Not applicable.
- (f) Para. 9.24, Jackscrew Retention: Not applicable.
- (g) Para. 9.27, Maintenance Aging: Not applicable.
- (h) Para. 9.30, Probe Damage: Not applicable.

4.2.5 Deviations from Lot Acceptance Tests (Chart V)

- (a) Para. 9.1.1.4, Mated Shell Conductivity: Not applicable.
- (b) Para. 9.9, Seal Test: Not applicable.
- (c) Para. 9.17, Contact Retention: For solder 90° PCB contacts, the force applied to the engagement end of the contact shall be compression only.
- (d) Para. 9.22, Corrosion: Not applicable.
- (e) Para. 9.27, Maintenance Aging: Not applicable.
- (f) Para. 9.30, Probe Damage: Not applicable.

4.3 MECHANICAL REQUIREMENTS

4.3.1 Dimension Check

The dimensions of the connectors specified herein shall be verified in accordance with the requirements set out in Para. 9.6 of ESCC Generic Specification No. 3401 and shall conform to those shown in Figure 2 of this specification. Only the following dimensions shall be checked during procurement:

Figure 2(a):

- Between centres of guiding or locking device. (Dimension A).
- Dimension D (where applicable).

Figure 2(b):

- Protrusion of guiding/locking devices.
- Overall dimensions of guiding/locking devices.

Figure 2(c):

- All dimensions.

4.3.2 Weight

The maximum weight of the connectors, with contacts and guiding and locking devices specified herein, shall be as specified in Table 1(a).

4.3.3 Contact Capability

For the purpose of this test, the pick-up and drop weights shall be as follows.

	Pick-up Weight	Drop Weight
Weight (g)	12	90
Pin Diameter (mm)	0.475 - 0.48	0.5 - 0.505
Insertion Depth (mm)	4	4

4.3.4 Contact Retention (In Insert)

The contact retention force within the insert shall be 40N minimum (compression) and 25N maximum (tension).

4.3.5 Mating and Unmating Forces

For cases where contacts are soldered on PCB, the forces applied for mating and unmating of the connectors shall not be more than 1N per contact.

For cases where contacts are not soldered on PCB, the forces applied for mating and unmating of the connectors shall not be more than 0.7N per contact.

4.3.6 Insert Retention (In Shell)

Not applicable.

4.3.7 Jackscrew Retention

Not applicable.

4.3.8 Contact Insertion and Withdrawal Forces

Not applicable.

4.3.9 Engagement and Separation Forces

The diameter of the test pin and the engagement and separation forces of the female contact shall be as specified hereunder.

	Diameter (mm)		Engagement Max (N)	Separation (N)	
	Min	Max		Min	Max
Minimum Diameter Test Pin	0.475	0.48	-	0.12	-
Maximum Diameter Test Pin	0.5	0.505	0.9	-	0.9

4.3.10 Oversize Pin Exclusion

The diameter of the test pin shall be 0.6 ± 0.002 mm and the force applied to it shall be 90 grammes.

4.3.11 Probe Damage

Not applicable.

4.3.12 Solderability

Size B soldering iron shall be used. Only applicable to contact code numbers 10, 30, 31 and 40 (see Table 1(b)).

4.4 MATERIALS AND FINISHES

The materials and finishes shall be as specified herein. Where a definite material is not specified, a material which will enable the connectors specified herein to meet the performance requirements of this specification shall be used. Acceptance or approval of any constituent material does not guarantee acceptance of the finished product.

4.4.1 Shells

Not applicable.

4.4.2 Inserts

The inserts shall be made of glass-fibre-filled diallylphthalate resin.

4.4.3 Contacts

4.4.3.1 *Body*

The contact body shall be made of copper alloy.

- Male Contact and Saver: The plating shall be 1.27µm minimum gold over 1.27µm minimum nickel.
- Female Contact: The plating shall be 0.25µm minimum gold over 1.27µm minimum nickel.

4.4.3.2 *Female Contact Wire*

The wire shall be made of copper alloy.

The plating shall be 1.27µm minimum gold over 0.2µm minimum nickel.

4.4.3.3 *Female Contact Sleeve*

The sleeve shall be made of copper alloy. The plating shall be 0.25µm minimum gold over 0.8µm minimum nickel.

4.4.4 Contact Retaining Clip

Not applicable.

4.4.5 Guiding and Locking Devices

Guiding and locking devices shall be made of brass (nickel-plated), stainless steel or arcap alloy.

4.4.6 Magnetism Level

Not applicable.

4.5 MARKING

4.5.1 General

The marking of all components delivered to this specification shall be in accordance with the requirements of ESCC Basic Specification No. 21700 and the following paragraphs. When the component is too small to accommodate all of the marking as specified, as much as space permits shall be marked and the marking information, in full, shall accompany the component in its primary package.

The information to be marked, and the order of precedence, shall be as follows:

- (a) Contact Position.
- (b) The ESCC Component Number.
- (c) Characteristics.
- (d) Traceability information.

4.5.2 Contact Position

Contact position shall be marked on the inserts in accordance with Figure 2(a).

4.5.3 The ESCC Component Number

The ESCC Component Number shall be constituted and marked as follows:

Example: 340103901B

- Detail Specification Number: 3401039
- Type Variant (Note 1): 01
- Testing Level: B

NOTES:

1. Marking of the Type Variant is mandatory. No further reference to type variants is made in this specification.

4.5.4 Characteristics

The characteristics to be marked in the following order of precedence are (example):

144 55 51 121

- Number of contacts: 144
- Insert type: 55
- Type of contacts: 51
- Guiding and locking devices: 121

4.5.4.1 *Number of Contacts*

026 – 044 – 062 – 080 – 098 – 144.

4.5.4.2 *Insert*

Inserts shall be designated by the following code numbers.

Code No.	Description
44	Receptacle equipped with female contacts
55	Plug equipped with male contacts

4.5.4.3 *Contacts*

Contacts shall be designated by the following code numbers.

Code No.	Contact Description
10	Solder 90° for printed circuit board - Male
30	Solder straight for printed circuit board - Female
31	Long solder straight for printed circuit board - Female
40	Solder pot - Female
50	Wire-wrap, 2 wrapping levels - Female
51	Wire-wrap, 2 wrapping levels - Female
91	Contact for connector saver - Female - Male

4.5.4.4 *Guiding and Locking Devices*

Guiding and locking devices shall be designated by the following code numbers.

Code No.	Contact Description
110	Male Guide/Lock for plug
121	Female Guide/Lock (axial) for receptacle
143	Female Guide/Lock for receptacle
201	Male Guide/Lock with jackscrew
202	Female Guide/Lock with jackscrew
204	Female Guide/Lock with jackscrew, 90° mounting
206	Male Guide/Lock with jackscrew
703	Guide for connector saver

If the purchase order does not specify any guiding or locking devices, guiding devices 110 for plugs and 121 for receptacles shall be delivered.

4.5.5 Traceability Information

Traceability information shall be marked in accordance with the requirements of ESCC Basic Specification No. [21700](#).

4.6 ELECTRICAL MEASUREMENTS

4.6.1 Electrical Measurements at Room Temperature

The parameters to be measured in respect of electrical characteristics are scheduled in Table 2. Unless otherwise specified, the measurements shall be performed at $T_{amb} = +22 \pm 3^{\circ}C$.

4.6.2 Electrical Measurements at High and Low Temperatures (Table 3)

Not applicable.

4.6.3 Circuits for Electrical Measurements (Figure 4)

Not applicable.

4.7 BURN-IN AND ELECTRICAL MEASUREMENTS

Not applicable.

4.8 ENVIRONMENTAL AND ENDURANCE TESTS (CHARTS IV AND V OF ESCC GENERIC SPECIFICATION NO. 3401)

4.8.1 Measurements and Inspections on Completion of Environmental Tests

The parameters to be measured and inspections to be performed on completion of environmental testing shall be those specified in Table 6. Unless otherwise specified, the measurements shall be performed at $T_{amb} = +22 \pm 3^{\circ}\text{C}$.

4.8.2 Measurements and Inspections at Intermediate Points during Endurance Tests

Not applicable.

4.8.3 Measurements and Inspections on Completion of Endurance Tests

The parameters to be measured and inspections to be performed on completion of endurance testing are scheduled in Table 6. Unless otherwise specified, the measurements shall be performed at $T_{amb} = +22 \pm 3^{\circ}\text{C}$.

4.8.4 Conditions for Operating Life Test (Part of Endurance Testing)

Not applicable.

4.8.5 Electrical Circuit for Operating Life Test (Figure 5)

Not applicable.

4.8.6 Conditions for High Temperature Storage Test (Part of Endurance Testing)

The requirements for the high temperature storage test are specified in Section 9 of ESCC Generic Specification No. 3401. The conditions for high temperature storage testing shall be the maximum storage temperature specified in Table 1(b) of this specification.

TABLE 2 – ELECTRICAL MEASUREMENTS AT ROOM TEMPERATURE

No.	Characteristics	Symbol	Spec. and/or Test Method	Test Condition	Limits		Unit
					Min	Max	
1	Insulation Resistance	Ri	ESCC No. 3401 Para. 9.1.1.1	Para. 9.1.1.1	10000	-	MΩ
2	Voltage Proof Leakage Current (Sea Level)	I _L	ESCC No. 3401 Para. 9.1.1.2	800Vrms		1	mA
3	Mated Shell Conductivity (Voltage Drop)	Vd	ESCC No. 3401 Para. 9.1.1.4	Para. 9.1.1.4	Not applicable		mV
4	Contact Resistance (Low Level Current)	R _{cl}	ESCC No. 3401 Para. 9.1.1.3	All	-	12	mΩ
5	Contact Resistance (Rated Current) (1)	R _{cr}	ESCC No. 3401 Para. 9.1.1.3	2A	-	12	mΩ

NOTES:

- Contact Resistance at Rated Current is guaranteed but not tested during Final Production Tests (Chart II).

TABLES 3, 4 AND 5

Not applicable.

TABLE 6 – MEASUREMENTS AND INSPECTIONS ON COMPLETION OF ENVIRONMENTAL AND ENDURANCE TESTS

No.	ESCC Generic No. 3401		Measurements and Inspections		Symbol	Limits		Unit
	Environmental and Endurance Tests (1)	Test Method and Conditions	Identification	Conditions		Min	Max	
01	Seal Test	Para. 9.9	Not applicable			Not applicable		
02	Wiring	Para. 9.10				-	-	
03	Vibration	Para. 9.11	Initial Measurements Coupling Screw(s) Unlocking Torque Final Measurements Full Engagement Coupling Screw(s) Unlocking Torque Drift Visual Examination	-	-	Record Values		
				-	Δ	-25	+25	%
				-	-	-	-	
04	Shock or Bump	Para. 9.12	Full Engagement Visual Examination	- -	- -	-	-	
05	Climatic Sequence	Para. 9.13	Dry Heat Insulation Resistance Low Air Pressure Voltage Proof Leakage Curr. Damp Heat Insulation Resistance Final Measurements External Visual Inspection Insulation Resistance Voltage Proof Leakage Curr.	Table 2 Item 1 Figure 1 Immediately after test Table 2 Item 1 After 1-24 hrs Recovery ESCC 3401 Para. 9.7 Table 2 Item 1 Table 2 Item 2	Ri I _L Ri - Ri I _L	1000 ESCC 3401 Para. 9.13.5 100 ESCC 3401 Para. 9.7 Table 2 Item 1 Table 2 Item 2	MΩ MΩ	
06	Plating Thickness	Para. 9.14	Thickness	-	-	Para. 4.4.3 of this spec.		
07	Joint Strength	Para. 9.15	ESCC 3401 Para. 9.15	-	-	Not applicable		
08	Rapid Change of Temperature	Para. 9.16	Visual Examination Insulation Resistance Voltage Proof Leakage Curr.	-	-	-	-	
				Table 2 Item 1	Ri	Table 2 Item 1		
				Table 2 Item 2	I _L	Table 2 Item 2		
09	Contact Retention (In Insert)	Para. 9.17 & Para. 4.3.4 of spec.	Contact Displacement	-	-	ESCC 3401 Para. 9.17		

No.	ESCC Generic No. 3401		Measurements and Inspections		Symbol	Limits		Unit
	Environmental and Endurance Tests (1)	Test Method and Conditions	Identification	Conditions		Min	Max	
18	Overload Test	Para. 9.26	Internal Temperature Rated Current Contact Resistance Mated Shell Conductivity Insulation Resistance Voltage Proof Leakage Curr.	Table 2 Item 5 Table 2 Item 3 Table 2 Item 1 Table 2 Item 2	T Rcr Vd Ri I _L	-	+100 Table 2 Item 5 Not applicable Table 2 Item 1 Table 2 Item 2	°C
19	Maintenance Aging	Para. 9.27	Visual Examination Contact Retention Contact Insertion and Withdrawal Forces	- Para. 4.3.4 of this spec. Para. 4.3.8 of this spec.	-	-	- Not applicable Not applicable	
20	Engage/Separation Forces	Para. 9.28 & Para. 4.3.9 of this spec.	Force		F		Para. 4.3.9 of this spec.	
21	Oversize Pin Exclusion	Para. 9.29 & Para. 4.3.10 of this spec.	-	-	-		ESCC 3401 Para. 9.29	
22	Probe Damage	Para. 9.30 & Para. 4.3.11 of this spec.	Contact Separation Force	Para. 4.3.9 of this spec.			Not applicable	
23	Solderability	Para. 9.31 & Para. 4.3.12 of this spec.	-	-	-		ESCC 3401 Para. 9.31	

NOTES:

1. The tests in this Table refer to either Chart IV or V and shall be used as applicable.