



RESISTOR, FIXED, CHIP, METAL FOIL

BASED ON TYPE SMR-PW, SMV-PW

ESCC Detail Specification No. 4001/028

Issue 7	May 2026
---------	----------



LEGAL DISCLAIMER AND COPYRIGHT

European Space Agency, Copyright © 2026. All rights reserved.

The European Space Agency disclaims any liability or responsibility, to any person or entity, with respect to any loss or damage caused, or alleged to be caused, directly or indirectly by the use and application of this ESCC publication.

This publication, without the prior permission of the European Space Agency and provided that it is not used for a commercial purpose, may be:

- copied in whole, in any medium, without alteration or modification.
- copied in part, in any medium, provided that the ESCC document identification, comprising the ESCC symbol, document number and document issue, is removed.

DOCUMENTATION CHANGE NOTICE

(Refer to <https://escies.org> for ESCC DCR content)

DCR No.	CHANGE DESCRIPTION
1805	Specification upissued to incorporate changes per DCR.

TABLE OF CONTENTS

1	GENERAL	5
1.1	SCOPE	5
1.2	APPLICABLE DOCUMENTS	5
1.3	TERMS, DEFINITIONS, ABBREVIATIONS, SYMBOLS AND UNITS	5
1.4	THE ESCC COMPONENT NUMBER AND COMPONENT TYPE VARIANTS	5
1.4.1	The ESCC Component Number	5
1.4.1.1	Characteristics and/or Ratings Codes	5
1.5	COMPONENT TYPE VARIANTS AND RANGE OF COMPONENTS	6
1.6	MAXIMUM RATINGS	6
1.7	PHYSICAL DIMENSIONS	7
1.7.1	Variant 01 (2 Terminal Package)	7
1.7.2	Variant 02 (4 Terminal Package)	8
1.8	FUNCTIONAL DIAGRAM	9
1.9	MATERIALS AND FINISHES	9
1.9.1	Terminals	9
2	REQUIREMENTS	9
2.1	GENERAL	9
2.1.1	Deviations from the Generic Specification	9
2.1.1.1	Deviations from Production Control - Chart F2	9
2.1.1.2	Deviations from Screening Tests - Chart F3	10
2.1.1.3	Deviations from Qualification and Periodic Tests - Chart F4	11
2.1.1.4	Deviations from Data Documentation - Section 9	11
2.2	MARKING	11
2.3	OVERLOAD	11
2.4	RESISTANCE TO SOLDERING HEAT	11
2.5	ELECTRICAL MEASUREMENTS AT ROOM, HIGH AND LOW TEMPERATURES	12
2.5.1	Room Temperature Electrical Measurements	12
2.5.2	High and Low Temperatures Electrical Measurements	12
2.6	INTERMEDIATE AND END-POINT ELECTRICAL MEASUREMENTS	13
2.7	BURN-IN CONDITIONS	14
2.7.1	No-Bias Burn-in Conditions for 100% Testing	14
2.7.2	Biased Burn-in Conditions for Screening Sub-lot Samples	14
2.8	OPERATING LIFE CONDITIONS	14
	APPENDIX A	15

1 GENERAL

1.1 SCOPE

This specification details the ratings, physical and electrical characteristics and test and inspection data for the component type variants and/or the range of components specified below. It supplements the requirements of, and shall be read in conjunction with, the ESCC Generic Specification listed under Applicable Documents.

1.2 APPLICABLE DOCUMENTS

The following documents form part of this specification and shall be read in conjunction with it:

- (a) ESCC Generic Specification No. 4001.
- (b) A-QS-009, Isabellenhuetten Test Procedure for Infrared Measurement.

1.3 TERMS, DEFINITIONS, ABBREVIATIONS, SYMBOLS AND UNITS

For the purpose of this specification, the terms, definitions, abbreviations, symbols and units specified in ESCC Basic Specification No. 21300 shall apply.

1.4 THE ESCC COMPONENT NUMBER AND COMPONENT TYPE VARIANTS

1.4.1 The ESCC Component Number

The ESCC Component Number shall be constituted as follows:

Example: 4001028012R7D

- Detail Specification Reference: 4001028
- Component Type Variant Number: 01 (as required)
- Characteristic code: Resistance Value (2.7Ω): 2R7 (as required)
- Characteristic code: Resistance Tolerance (±0.5%): D (as required)

1.4.1.1 Characteristics and/or Ratings Codes

Characteristics and/or ratings to be codified as part of the ESCC Component Number shall be as follows:

- (a) Resistance Value expressed by means of the following codes. The unit quantity shall be ohm (Ω):

Resistance Value (Ω)	Code
0.00XX	R00XX
0.0XX	R0XX
0.XX	RXX
X.X	XRX

- (b) Resistance Tolerance expressed by the following codes in accordance with ESCC Basic Specification No. 21700:

Tolerance (± %)	Code Letter
0.5	D
1	F

1.5 COMPONENT TYPE VARIANTS AND RANGE OF COMPONENTS

The component type variants and range of components applicable to this specification are as follows:

Variant Number	Type	Style (Note 1)	Resistance Range R_n		Tolerance (\pm %)	Temperature Coefficient TC ($\pm 10^{-6}/K$)	Value Series	Weight max (g)
			Min (Ω)	Max (Ω)				
01	SMR-PW	4723 (2 Terminal)	0.01	4.7	0.5, 1	Note 2	E12	0.6
02	SMV-PW	4723 (4 Terminal)	0.0022	1	0.5, 1	Note 2	E12	0.6

NOTES:

- See Para. 1.7.
- Temperature Coefficient, TC, requirements:

Variant Number	Resistance (Ω)	Temperature Coefficient ($10^{-6}/K$)	Remarks
01	$0.01 \leq R_n \leq 4.7$	-125, +0	over $T_{amb} = -55^{\circ}C$ to $+22^{\circ}C$
		± 60	over $T_{amb} = +22^{\circ}C$ to $+140^{\circ}C$
		± 50	over $T_{amb} = +22^{\circ}C$ to $+60^{\circ}C$
02	$0.0022 \leq R_n \leq 1$	-125, +0	over $T_{amb} = -55^{\circ}C$ to $+22^{\circ}C$
		± 60	over $T_{amb} = +22^{\circ}C$ to $+140^{\circ}C$
	$0.0022 \leq R_n < 0.01$	± 50	over $T_{amb} = +22^{\circ}C$ to $+60^{\circ}C$
	$0.01 \leq R_n \leq 1$	± 30	

1.6 MAXIMUM RATINGS

The maximum ratings shall not be exceeded at any time during use or storage.

Maximum ratings shall only be exceeded during testing to the extent specified in this specification and when stipulated in Test Methods and Procedures of the ESCC Generic Specification.

Characteristics	Symbols	Limits	Units	Remarks
Rated Dissipation	P_n	3	W	Note 1
Rated Voltage	U_R	$\sqrt{P_n \times R_n}$	V	Note 2
Isolation Voltage	U_I	1000	V	-
Operating Temperature Range	T_{op}	-55 to +140	$^{\circ}C$	T_{amb}
Storage Temperature Range	T_{stg}	-55 to +140	$^{\circ}C$	-
Soldering Temperature	T_{sol}	+260	$^{\circ}C$	Note 3

NOTES:

- At $T_{amb} \leq +80^{\circ}C$. For $T_{amb} > +80^{\circ}C$, derate linearly to 0W at $T_{amb} = +140^{\circ}C$.
- R_n = rated resistance.
- Duration 5 seconds maximum.

1.7 PHYSICAL DIMENSIONS

1.7.1 Variant 01 (2 Terminal Package)

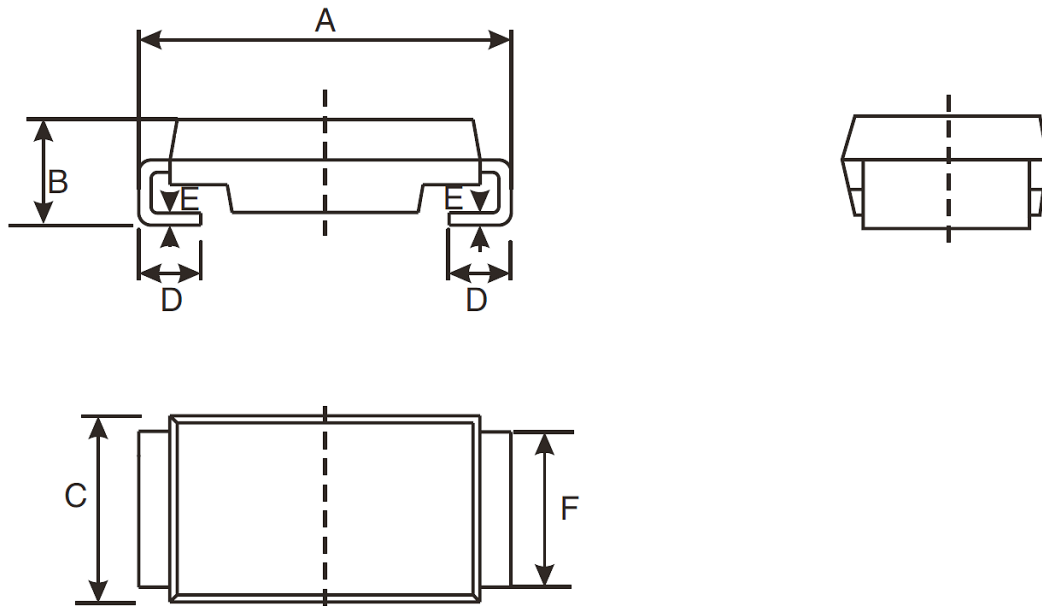

Symbols	Dimensions (mm)		Notes
	Min	Max	
A	11.9	12.3	
B	3.2	3.6	
C	5.9	6.6	
D	1.5	2.5	both terminals
E	0.3	0.5	both terminals
F	4.9	5.3	both terminals

1.7.2 Variant 02 (4 Terminal Package)

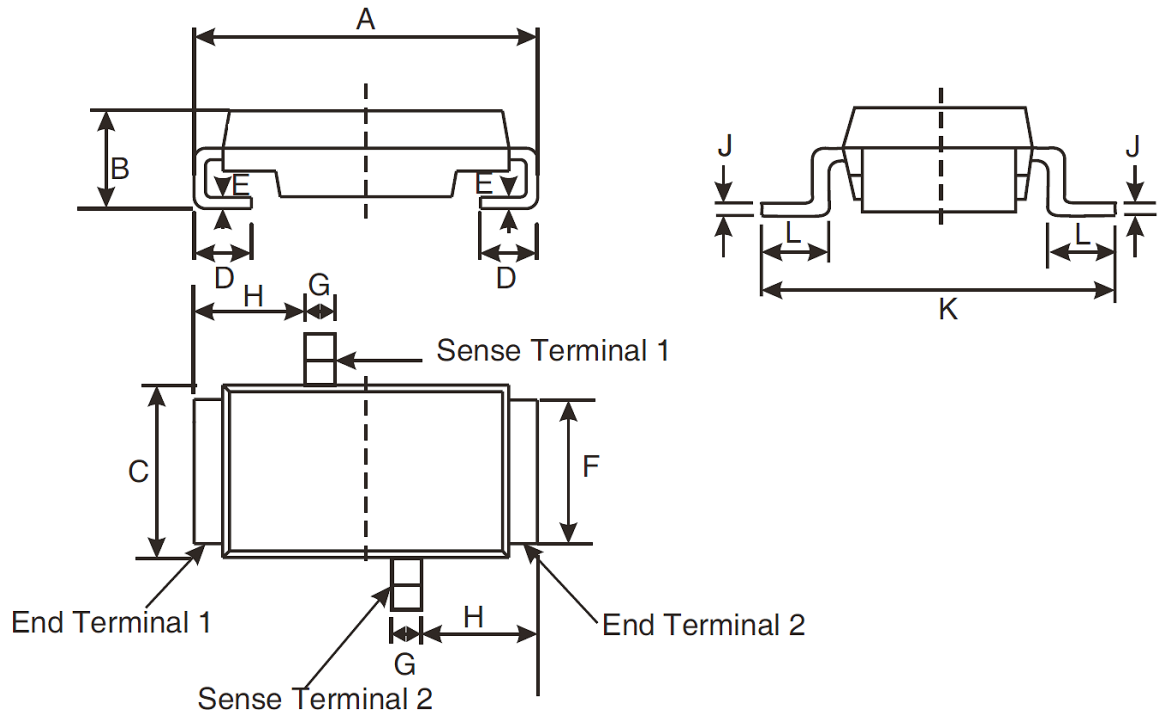

Symbols	Dimensions (mm)		Notes
	Min	Max	
A	11.9	12.3	
B	3.2	3.6	
C	5.9	6.6	
D	1.5	2.5	both end terminals
E	0.3	0.5	both end terminals
F	4.9	5.3	both end terminals
G	0.8	1.3	both sense terminals
H	4.3	4.9	
J	0.3	0.5	both sense terminals
K	8.8	9.6	
L	0.85	1.45	both sense terminals

1.8 FUNCTIONAL DIAGRAM

VARIANT 01

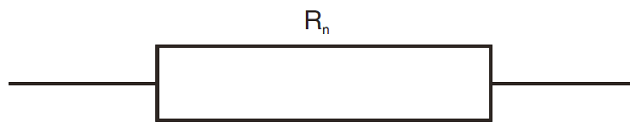

VARIANT 02

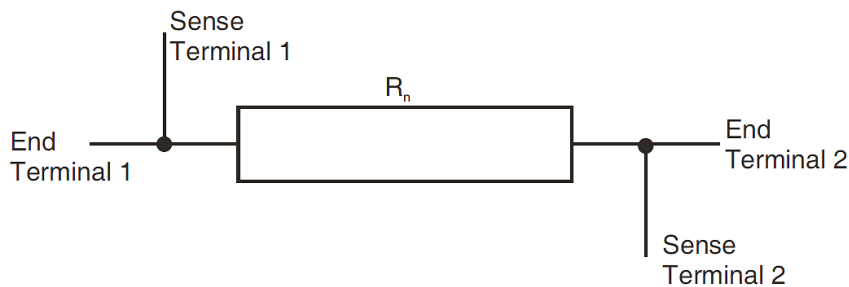

1.9 MATERIALS AND FINISHES

1.9.1 Terminals

The terminal finish shall be electroplated tin-lead (with 30% to 80% tin; remainder lead) to a maximum thickness of 70 μ m.

2 REQUIREMENTS

2.1 GENERAL

The complete requirements for procurement of the components specified herein are as stated in this specification and the ESCC Generic Specification. Permitted deviations from the Generic Specification, applicable to this specification only, are listed below.

Permitted deviations from the Generic Specification and this Detail Specification, formally agreed with specific Manufacturers on the basis that the alternative requirements are equivalent to the ESCC requirement and do not affect the component's reliability, are listed in the appendices attached to this specification.

2.1.1 Deviations from the Generic Specification

2.1.1.1 *Deviations from Production Control - Chart F2*

(a) Prior to body moulding, a 100% Infrared Measurement in accordance with A-QS-009 shall be performed on each resistor element:

- Applied Voltage: $\sqrt{(5P_n \times R_n)}$
- Duration: 10ms

2.1.1.2 Deviations from Screening Tests - Chart F3

(a) Screening Sub-lot Samples Selection, Mounting and Testing

A quantity of 20 components shall be selected at random from the production lot and mounted in accordance with ESCC Generic Specification No. 4001 Para. 8.7. These mounted Screening Sub-lot samples shall be serialised and subjected to tests and inspections of Chart F3 in parallel with the 100% testing.

For each test requiring electrical measurements the results shall be recorded against component serial number. These samples shall not form part of the delivery lot.

(b) Microsection Examination

A quantity of 10 components selected at random from the production lot at the same time as the Screening Sub-lot samples, shall be subjected to microsection examination of internal solder joints. These samples shall not form part of the delivery lot. The following requirements shall apply:

- The 10 samples shall be prepared for microsection examination by individually mounting them in suitable epoxy filled moulds.
- Each sample shall be cut, polished and examined sequentially in several parallel planes. The planes shall be chosen such that:
 - All internal solder joints can be examined.
 - Each internal solder joint is cut perpendicular to the joint plane thereby facilitating the examination for any voids in the solder joint.
 - Each internal solder joint is sectioned and examined in 3 separate planes distributed along its length.
- Examination for any voids shall be performed for each solder joint in each of the 3 planes. Any voids identified in a solder joint in any of the 3 examinations, that total $\geq 50\%$ of the visible solder joint area shall constitute a reject.
- A single reject shall be cause for production lot failure and the Manufacturer shall act in accordance with Lot Failure in ESCC Generic Specification No. 4001 Para. 4.3.3.
- Photographic results of all examinations traceable to the production lot, shall be included in the Screening Tests data documentation.

(c) Para. 8.1 Overload

Overload shall only be performed on the mounted Screening Sub-lot samples. Resistance shall be measured as specified in Room Temperature Electrical Measurements both before and after Overload. Change in Resistance shall be calculated, recorded against component serial number, and shall not exceed the limit as follows:

- Change in Resistance during Overload: $\pm 0.3\%$ max

(d) Para. 8.2, Non-Linearity: Not applicable.

(e) Para. 8.3.2, Room Temperature Electrical Measurements

For the testing of the mounted Screening Sub-lot samples, Resistance shall be recorded against component serial number both before and after Burn-in. Change in Resistance shall be calculated, recorded against component serial number, and shall not exceed the limit as follows:

- Change in Resistance during Burn-in: $\pm 0.2\%$ max.

- (f) Para. 8.4 Burn-in:
For the 100% Testing during Chart F3, burn-in in accordance with No-Bias Burn-in of this specification shall be performed with a duration of 24 (+24, -0) hours.
For the testing of the mounted Screening Sub-lot samples, burn-in in accordance with Biased Burn-in of this specification shall be performed with a duration of 168 (+24 -0) hours.
- (g) Para. 6.4 Check for Lot Failure
0 failures are allowed during all Chart F3 testing of the mounted Screening Sub-lot samples. In the event of any failure the lot shall be considered as failed.

2.1.1.3 *Deviations from Qualification and Periodic Tests - Chart F4*

- (a) Para. 8.11, Robustness of Terminations: Not applicable.

2.1.1.4 *Deviations from Data Documentation - Section 9*

- (a) Para. 9.6, Screening Tests Data: For each test performed on the mounted Screening Sub-lot samples requiring electrical measurements, the results shall be recorded against component serial number. Component drift calculations shall be recorded for each specified test against component serial number.

2.2 MARKING

The marking of all components delivered to this specification shall be in accordance with the requirements of ESCC Basic Specification No. 21700. When the component is too small to accommodate all of the marking specified, as much as space permits shall be marked and the marking information, in full, shall accompany each component in its primary package.

The information to be marked and the order of precedence, shall be as follows:

- (a) The ESCC qualified components symbol (for ESCC qualified components only).
- (b) The ESCC Component Number (see Para. 1.4.1).
- (c) Traceability information.

2.3 OVERLOAD

The test conditions for Overload, tested as specified in the ESCC Generic Specification, shall be as follows:

- Voltage: $\sqrt{(5P_n \times R_n)}$
- Duration: 5s

2.4 RESISTANCE TO SOLDERING HEAT

The test conditions for Resistance to Soldering Heat, tested as specified in the ESCC Generic Specification, shall be as follows:

- Temperature: 260°C
- Duration: 5 (+0 -1)s

2.5 ELECTRICAL MEASUREMENTS AT ROOM, HIGH AND LOW TEMPERATURES

2.5.1 Room Temperature Electrical Measurements

The measurements shall be performed at $T_{amb} = +22 \pm 3^{\circ}\text{C}$.

Characteristics	Symbols	ESCC 4001 Test Method and Conditions	Tolerance (\pm %)	Limits		Units
				Min	Max	
Resistance	R_A	Para. 8.3.1.1	0.5	$0.995 R_n$	$1.005 R_n$	Ω
			1	$0.99 R_n$	$1.01 R_n$	
Insulation Resistance	R_i	Para. 8.3.1.2 $V = 500\text{V}$, Note 1	All	1000	-	$\text{M}\Omega$

NOTES:

1. Guaranteed but not tested during Screening Tests.

2.5.2 High and Low Temperatures Electrical Measurements

Characteristics	Symbols	ESCC 4001 Test Method and Conditions	Limits		Units
			Min	Max	
Resistance Change between $-55 (+3 -0)^{\circ}\text{C}$ and $+22 \pm 3^{\circ}\text{C}$	$\Delta R_A/R_A$	Para. 8.3.1.1 Note 1 $\text{TC} = -125/+0 \times 10^{-6}/\text{K}$:	-1	+0	%
Resistance Change between $+140 (+0 -3)^{\circ}\text{C}$ and $+22 \pm 3^{\circ}\text{C}$	$\Delta R_A/R_A$	Para. 8.3.1.1 Note 1 $\text{TC} = \pm 60 \times 10^{-6}/\text{K}$:	-0.726	+0.726	%
Resistance Change between $+60 \pm 3^{\circ}\text{C}$ and $+22 \pm 3^{\circ}\text{C}$	$\Delta R_A/R_A$	Para. 8.3.1.1 Note 2 $\text{TC} = \pm 30 \times 10^{-6}/\text{K}$: $\text{TC} = \pm 50 \times 10^{-6}/\text{K}$:	-0.132	+0.132	%
			-0.22	+0.22	

NOTES:

1. The measurements shall be performed on all the mounted Screening Sub-lot samples.
2. The measurements shall be performed on a sample of 5 components selected from the total production lot.

2.6 INTERMEDIATE AND END-POINT ELECTRICAL MEASUREMENTS

The components shall be mounted as specified in the ESCC Generic Specification.

Unless otherwise specified, the measurements shall be performed at $T_{amb} = +22 \pm 3^{\circ}C$.

Unless otherwise specified the test methods and test conditions shall be as per the corresponding test defined in Para. 2.5.1 Room Temperature Electrical Measurements.

Test Reference per ESCC No. 4001	Characteristics	Symbols	Limits		Units
			Min	Max	
Rapid Change of Temperature	Resistance	R_A	Record Values		
Initial Measurement					
Final Measurement	Change in Resistance	$\Delta R_A/R_A$	± 0.2		%
Vibration	Resistance	R_A	Record Values		
Initial Measurement					
Final Measurement	Change in Resistance	$\Delta R_A/R_A$	± 0.2		%
Resistance to Soldering Heat	Resistance	R_A	Record Values		
Initial Measurement					
Final Measurement	Change in Resistance	$\Delta R_A/R_A$	± 0.3		%
Solderability	Resistance	R_A	Record Values		
Initial Measurement					
Final Measurement	Change in Resistance	$\Delta R_A/R_A$	± 0.2		%
Climatic Sequence	Resistance (after drying)	R_A	Record Values		
Initial Measurements (Procedure 1)					
Final Measurements	Change in Resistance	$\Delta R_A/R_A$	± 0.3		%
	Insulation Resistance	R_I	1000	-	$M\Omega$
Operating Life	Resistance	R_A	Record Values		
Initial Measurement (0 hour)					
Intermediate Measurements (1000 hours)	Change in Resistance	$\Delta R_A/R_A$	± 0.25		%
Final Measurements (2000 hours)	Change in Resistance	$\Delta R_A/R_A$	± 0.4		%
	Insulation Resistance	R_I	1000	-	$M\Omega$

2.7 BURN-IN CONDITIONS

2.7.1 No-Bias Burn-in Conditions for 100% Testing

Characteristics	Symbols	Conditions (Note 1)	Units
Ambient Temperature	T _{amb}	+140 (+0 -5)	°C
Test Voltage	V _T	No Bias	V

NOTES:

1. No-Bias Burn-in (High Temperature Bake) shall be performed on components that are not mounted.
2. No-Bias Burn-in duration shall be 24 (+24 -0) hours.
3. After Burn-in, the components shall be removed from the chamber and allowed to cool under normal atmospheric conditions for a minimum of 1 hour. They shall then be visually examined. There shall be no evidence of damage and marking shall still be legible.

2.7.2 Biased Burn-in Conditions for Screening Sub-lot Samples

Characteristics	Symbols	Conditions (Note 1)	Units
Terminal Temperature	T _{term}	+80 (+0 -3)	°C
Test Voltage	V _T	$\sqrt{(P_n \times R_n)}$	V

NOTES:

1. Biased Burn-in shall be performed on the applicable sample components that are mounted in accordance with ESCC Generic Specification No. 4001 Para. 8.7.
2. Biased Burn-in duration shall be 168 (+24 -0) hours.
3. After Burn-in, the components shall be removed from the chamber and allowed to cool under normal atmospheric conditions for a minimum of 1 hour. They shall then be visually examined. There shall be no evidence of damage and marking shall still be legible.

2.8 OPERATING LIFE CONDITIONS

The conditions shall be as specified in Para. 2.7.2 for Biased Burn-in.

APPENDIX A
AGREED DEVIATIONS FOR ISABELLENHUETTE (D)

Items Affected	Description of Deviations										
Para. 2.1.1.1 Deviations from Generic Specification: Production Control - Chart F2	Para. 5.2.1, Dimension Check: A 100% inspection may be performed.										
Para. 2.1.1.2 Deviations from Generic Specification: Screening Tests - Chart F3	Para. 8.1, Overload: For Variant 02, any holes or cracks identified during visual examination that do not fail the criteria of Para. 8.6, as below, shall not be considered as evidence of damage. Para. 8.6, External Visual Inspection: For Variant 02, the specific requirements of ESCC Basic Specification No. 2054000 shall apply with the following deviations: <ul style="list-style-type: none"> • Para. 3.1, Magnification: All items shall be examined with a stereoscopic microscope with a magnification of between 5 and 20 power (x5 to x20). • Paras. 4.4(b) & 4.4(c): These reject criteria are not applicable. • Add new reject criteria to Para. 4.4 as follows: <ul style="list-style-type: none"> ○ Moulding material showing holes or cracks whose total surface area exceeds 3% of the total surface area of the moulding or coating material. ○ Any holes or cracks in the moulding material that bridge the space between any 2 terminals. 										
Para. 2.1.1.3 Deviations from Generic Specification: Qualification and Periodic Tests - Chart F4	Para. 8.6, External Visual Inspection: As for Screening Tests above. Paras. 8.8, 8.9, 8.11 & 8.12, Rapid Change of Temperature, Vibration, Robustness of Terminations & Resistance to Soldering Heat: For Variant 02, any holes or cracks identified during visual examination that do not fail the criteria of Para. 8.6, as above, shall not be considered as evidence of damage. Para. 8.8, Rapid Change of Temperature: A high temperature extreme of $T_{amb} = +150 (+0 -3)^{\circ}C$ may be applied during testing. Para. 8.10, Climatic Sequence: <ul style="list-style-type: none"> • Para. 8.10.5, Low Air Pressure: Not applicable. • Para. 8.10.7, DC Load: Not applicable. Para. 8.15, Permanence of Marking: Not applicable.										
Para. 1.4.1.1 Characteristics Codes: Resistance Value	Resistance Value shall be expressed by means of the following codes within the ESCC Component Number. The unit quantity shall be ohm (Ω): <table border="1" data-bbox="568 1733 1043 1953"> <thead> <tr> <th>Resistance Value (Ω)</th> <th>Code</th> </tr> </thead> <tbody> <tr> <td>0.00XX</td> <td>R00XX</td> </tr> <tr> <td>0.0XX</td> <td>R0XX</td> </tr> <tr> <td>0.XXX</td> <td>RXXX</td> </tr> <tr> <td>X.XX</td> <td>XRXX</td> </tr> </tbody> </table>	Resistance Value (Ω)	Code	0.00XX	R00XX	0.0XX	R0XX	0.XXX	RXXX	X.XX	XRXX
Resistance Value (Ω)	Code										
0.00XX	R00XX										
0.0XX	R0XX										
0.XXX	RXXX										
X.XX	XRXX										

Items Affected	Description of Deviations
Para. 1.5 Component Type Variants and Range of Components	For all Variants, additional resistance values, R_n , from within the specified Resistance Range, but outside of the specified Value Series, are available upon request from Isabellenhuetten.
	Value Series (all Variants): $R_n = 0.33\Omega$ (resistance code: R330) is not available.
Para. 2.2 Marking: Marking of Tolerance on Resistance Value	The tolerance on resistance value may be marked using the actual numeric value (0.5% or 1%) instead of the specified code letter.
Para. 2.2 Marking: Marking of Traceability Information	The manufacturing date code may be marked using a three-digit code where: <ul style="list-style-type: none"> • the first digit is a letter to indicate the year of manufacture in accordance with the first digit of the two-character code for year and month in a twenty-year cycle in IEC Publication No. 60062. • the last two digits indicate the week of the year (i.e. 01 to 52) during which encapsulation or the final production process occurred. For example: R41 for week 41 of 2023