



**INTEGRATED CIRCUITS, SILICON MONOLITHIC,
BIPOLAR 4-BIT BI-DIRECTIONAL UNIVERSAL
SHIFT REGISTER,
BASED ON TYPE 54S194
ESCC Detail Specification No. 9306/031**

**ISSUE 1
October 2002**



	ESCC Detail Specification		PAGE ii ISSUE 1
---	---------------------------	--	--------------------

LEGAL DISCLAIMER AND COPYRIGHT

European Space Agency, Copyright © 2002. All rights reserved.

The European Space Agency disclaims any liability or responsibility, to any person or entity, with respect to any loss or damage caused, or alleged to be caused, directly or indirectly by the use and application of this ESCC publication.

This publication, without the prior permission of the European Space Agency and provided that it is not used for a commercial purpose, may be:

- copied in whole in any medium without alteration or modification.
- copied in part, in any medium, provided that the ESCC document identification, comprising the ESCC symbol, document number and document issue, is removed.



europaean space agency
agence spatiale européenne

Pages 1 to 28

**INTEGRATED CIRCUITS, SILICON MONOLITHIC,
BIPOLAR 4-BIT BI-DIRECTIONAL UNIVERSAL
SHIFT REGISTER,
BASED ON TYPE 54S194**

ESA/SCC Detail Specification No. 9306/031



**space components
coordination group**

Issue/Rev.	Date	Approved by	
		SCCG Chairman	ESA Director General or his Deputy
Issue 2	April 1994	<i>P. Rommens</i>	<i>T. Lederer</i>

**DOCUMENTATION CHANGE NOTICE**

Rev. Letter	Rev. Date	Reference	CHANGE Item	Approved DCR No.
			This Issue supersedes Issue 1 and incorporates all modifications defined in Revisions 'A', 'B', 'C' and 'D' to Issue 1 and the following DCR's:-	
		Cover page		None
		DCN		None
		Table 1(a)	: Lead Material and/or Finish amended for existing Variants	22881
			: Variants 11 and 12 added	22881
		Table 1(b)	: No. 2, in Remarks, Note No. amended to "1"	23573
			: No. 3, Characteristics, Symbol and Maximum Rating amended	221172
			: , in Remarks, Note No. amended to "2"	23573
			: No. 6, existing temperature specified for DIL/FP	23573
			, new temperature and Note reference added for CCP	23573
			: Note 1 renumbered as "2"	23573
			: Note 2 renumbered as "3" and text amended	23573
			: Note 3 renumbered as "1"	23573
			: New Note 4 added	23573
		Figures 2(a), (b)	: Drawing and Table amended	221151
		Figure 2(c)	: Imperial dimensions deleted	22881
			: Reference to Note 6 amended to "Note 10"	23644
		Figure 2(d)	: New figure added	22881
		Notes to Figures	: Title of the notes amended	22881
			: Note 1, last sentence added	22881
			: Notes 5 and 6, Imperial dimensions deleted	22881
			: Note 8, 'or terminals' added	22881
			: Note 9, rewritten	22881
			: Notes 11 and 12 added	22881
		Figure 3(a)	: Figure for chip carrier package added	22881
			: Subtitles added above both drawings	22881
			: Comparison table added	22881
			: Note 1 added	22881
		Figure 3(b)	: Notes corrected	23644/ 23650
		Para. 4.2.2	: PIND deviation deleted, "None" added	21048
		Para. 4.2.4	: Deviation deleted, "None" added	22919
		Para. 4.2.5	: Deviation deleted, "None" added	22919
		Para. 4.3.2	: Paragraph rewritten	23460
			: Maximum weight limits amended	221047
		Para. 4.4.2	: Paragraph rewritten	22881
		Para. 4.5.2	: Paragraph rewritten	22881
		Para. 4.5.3	: Paragraph standardised	23644
		Para. 4.6.3	: "...and functional test sequence..." deleted	23644
		Para. 4.7.1	: "T _{amb} " added before "... + 22 ± 3°C"	23644
		Paras. 4.7.2 & 4.7.3	: In title and paragraph, "burn-in" amended to read "power burn-in"	23644
		Tables 2 and 3	: Nos. 2 to 11, in Conditions, V _{IN} corrected to "2.7V"	23650
			: Nos. 22 to 31, Test Method corrected	23650
		Table 2	: No. 54, Limits amended	221172
			: Note 1 corrected	23650

**SCC**ESA/SCC Detail Specification
No. 9306/031

PAGE 2A

ISSUE 2

DOCUMENTATION CHANGE NOTICE

Rev. Letter	Rev. Date	Reference	CHANGE Item	Approved DCR No.
		Table 3	: No. 54, Characteristics, Test Conditions and Limits amended	221172
		Para. 4.8	: Title amended	23644
		Para. 4.8.2	: Second sentence added	23650
		Para. 4.8.5	: Text completed	23650
		Table 6	: Nos. 12 to 21, Characteristics corrected	23650

**SCC**

ESA/SCC Detail Specification

No. 9306/031

PAGE 3

ISSUE 2

TABLE OF CONTENTS

	<u>Page</u>
1. <u>GENERAL</u>	5
1.1 Scope	5
1.2 Component Type Variants	5
1.3 Maximum Ratings	5
1.4 Parameter Derating Information	5
1.5 Physical Dimensions	5
1.6 Pin Assignment	5
1.7 Truth Table	5
1.8 Circuit Schematic	5
1.9 Functional Diagram	5
2. <u>APPLICABLE DOCUMENTS</u>	15
3. <u>TERMS, DEFINITIONS, ABBREVIATIONS, SYMBOLS AND UNITS</u>	15
4. <u>REQUIREMENTS</u>	15
4.1 General	15
4.2 Deviations from Generic Specification	15
4.2.1 Deviations from Special In-process Controls	15
4.2.2 Deviations from Final Production Tests	15
4.2.3 Deviations from Burn-in Tests	15
4.2.4 Deviations from Qualification Tests	15
4.2.5 Deviations from Lot Acceptance Tests	15
4.3 Mechanical Requirements	16
4.3.1 Dimension Check	16
4.3.2 Weight	16
4.4 Materials and Finishes	16
4.4.1 Case	16
4.4.2 Lead Material and Finish	16
4.5 Marking	16
4.5.1 General	16
4.5.2 Lead Identification	16
4.5.3 The SCC Component Number	17
4.5.4 Traceability Information	17
4.6 Electrical Measurements	17
4.6.1 Electrical Measurements at Room Temperature	17
4.6.2 Electrical Measurements at High and Low Temperatures	17
4.6.3 Circuits for Electrical Measurements	17
4.7 Burn-in Tests	17
4.7.1 Parameter Drift Values	17
4.7.2 Conditions for Power Burn-in	17
4.7.3 Electrical Circuits for Power Burn-in	17
4.8 Environmental and Endurance Tests	26
4.8.1 Electrical Measurements on Completion of Environmental Tests	26
4.8.2 Electrical Measurements at Intermediate Points during Endurance Tests	26
4.8.3 Electrical Measurements on Completion of Endurance Tests	26
4.8.4 Conditions for Operating Life Tests	26
4.8.5 Electrical Circuits for Operating Life Tests	26
4.8.6 Conditions for High Temperature Storage Test	26

Page**TABLES**

1(a)	Type Variants	6
1(b)	Maximum Ratings	6
2	Electrical Measurements at Room Temperature, D.C. Parameters	18
	Electrical Measurements at Room Temperature, A.C. Parameters	19
3	Electrical Measurements at High and Low Temperatures	20
4	Parameter Drift Values	24
5	Conditions for Power Burn-in and Operating Life Test	24
6	Electrical Measurements on Completion of Environmental Tests and at Intermediate Points and on Completion of Endurance Tests	27

FIGURES

1	Not applicable	N/A
2	Physical Dimensions	7
3(a)	Pin Assignment	12
3(b)	Truth Table	13
3(c)	Circuit Schematic	14
3(d)	Functional Diagram	14
4	Circuits for Electrical Measurements	21
5	Electrical Circuit for Power Burn-in and Operating Life Test	25

APPENDICES (Applicable to specific Manufacturers only)

'A'	Agreed Deviations for Texas Instruments (F)	28
-----	---	----

**1. GENERAL****1.1 SCOPE**

This specification details the ratings, physical and electrical characteristics, test and inspection data for a silicon monolithic, bipolar, Schottky 4-Bit Bi-directional Universal Shift Register, based on Type 54S194. It shall be read in conjunction with ESA/SCC Generic Specification No. 9000, the requirements of which are supplemented herein.

1.2 COMPONENT TYPE VARIANTS

Variants of the basic type integrated circuits specified herein, which are also covered by this specification, are given in Table 1(a).

1.3 MAXIMUM RATINGS

The maximum ratings, which shall not be exceeded at any time during use or storage, applicable to the integrated circuits specified herein, are as scheduled in Table 1(b).

1.4 PARAMETER DERATING INFORMATION (FIGURE 1)

Not applicable.

1.5 PHYSICAL DIMENSIONS

The physical dimensions of the integrated circuits specified herein are shown in Figure 2.

1.6 PIN ASSIGNMENT

As per Figure 3(a).

1.7 TRUTH TABLE

As per Figure 3(b).

1.8 CIRCUIT SCHEMATIC

As per Figure 3(c).

1.9 FUNCTIONAL DIAGRAM

As per Figure 3(d).

**TABLE 1(a) - TYPE VARIANTS**

VARIANT	CASE	FIGURE	LEAD MATERIAL AND/OR FINISH
01	FLAT	2(a)	D7
02	FLAT	2(a)	G4
05	DIL	2(b)	D7
06	DIL	2(b)	G4
07	DIL	2(c)	D7
08	DIL	2(c)	D3 or D4
11	CCP	2(d)	7
12	CCP	2(d)	4

TABLE 1(b) - MAXIMUM RATINGS

No.	CHARACTERISTICS	SYMBOL	MAXIMUM RATINGS	UNIT	REMARKS
1	Supply Voltage	V_{CC}	-0.5 to 7.0	V	-
2	Input Voltage	V_{IN}	-0.5 to 5.5	V	Note 1
3	Device Dissipation	PD	605	mWdc	Note 2
4	Operating Temperature Range	T_{op}	-55 to +125	°C	-
5	Storage Temperature Range	T_{stg}	-65 to +150	°C	-
6	Soldering Temperature For FP and DIP For CCP	T_{sol}	+265 +245	°C	Note 3 Note 4

NOTES

1. Input current limited to -18mA.
2. Must withstand added P_D due to short circuit conditions (i.e. I_{OS}) at one output for 5 seconds.
3. Duration 10 seconds maximum at a distance of not less than 1.5mm from the device body and the same lead shall not be resoldered until 3 minutes have elapsed.
4. Duration 5 seconds maximum and the same terminal shall not be resoldered until 3 minutes have elapsed.



FIGURE 2 - PHYSICAL DIMENSIONS

FIGURE 2(a) - FLAT PACKAGE

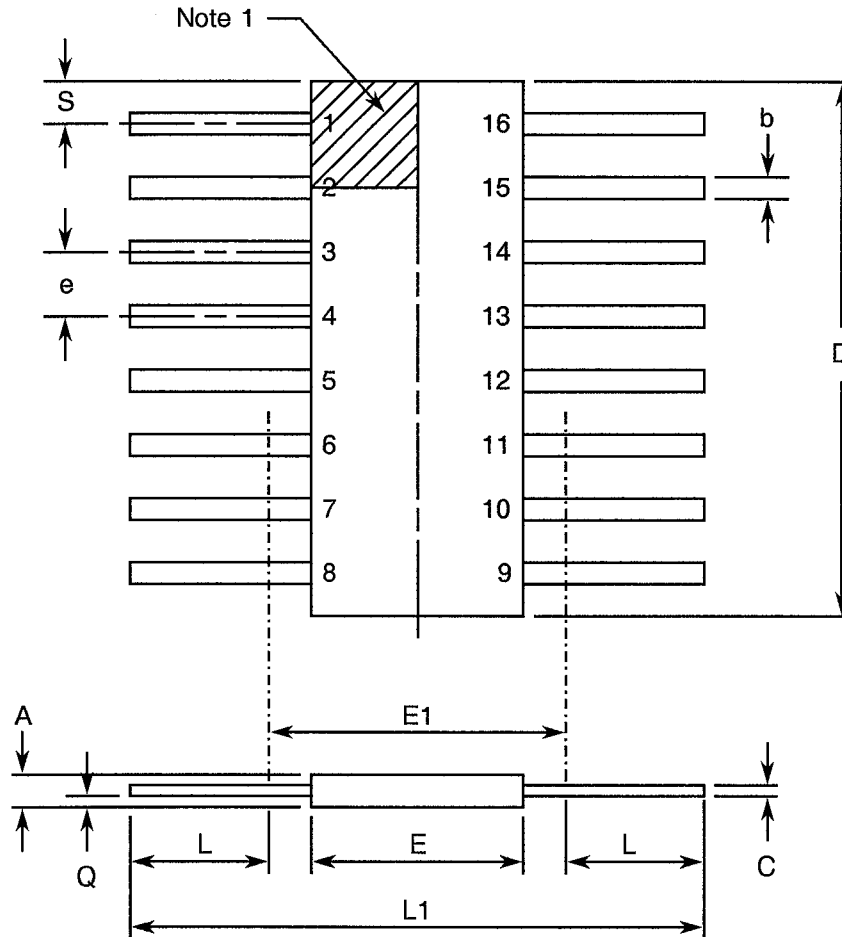

SYMBOL	MILLIMETRES		NOTES
	MIN	MAX	
A	1.27	2.03	
b	0.38	0.56	8
C	0.08	0.23	8
D	9.42	10.16	4
E	6.27	7.24	
E1	7.00 TYPICAL		4
e	1.27 TYPICAL		5, 9
L	7.87	8.89	8
L1	23.88	24.38	
Q	0.51	1.02	2
S	0.25	0.64	7

NOTES: See Page 11.



FIGURE 2 - PHYSICAL DIMENSIONS (CONTINUED)

FIGURE 2(b) - DUAL-IN-LINE PACKAGE

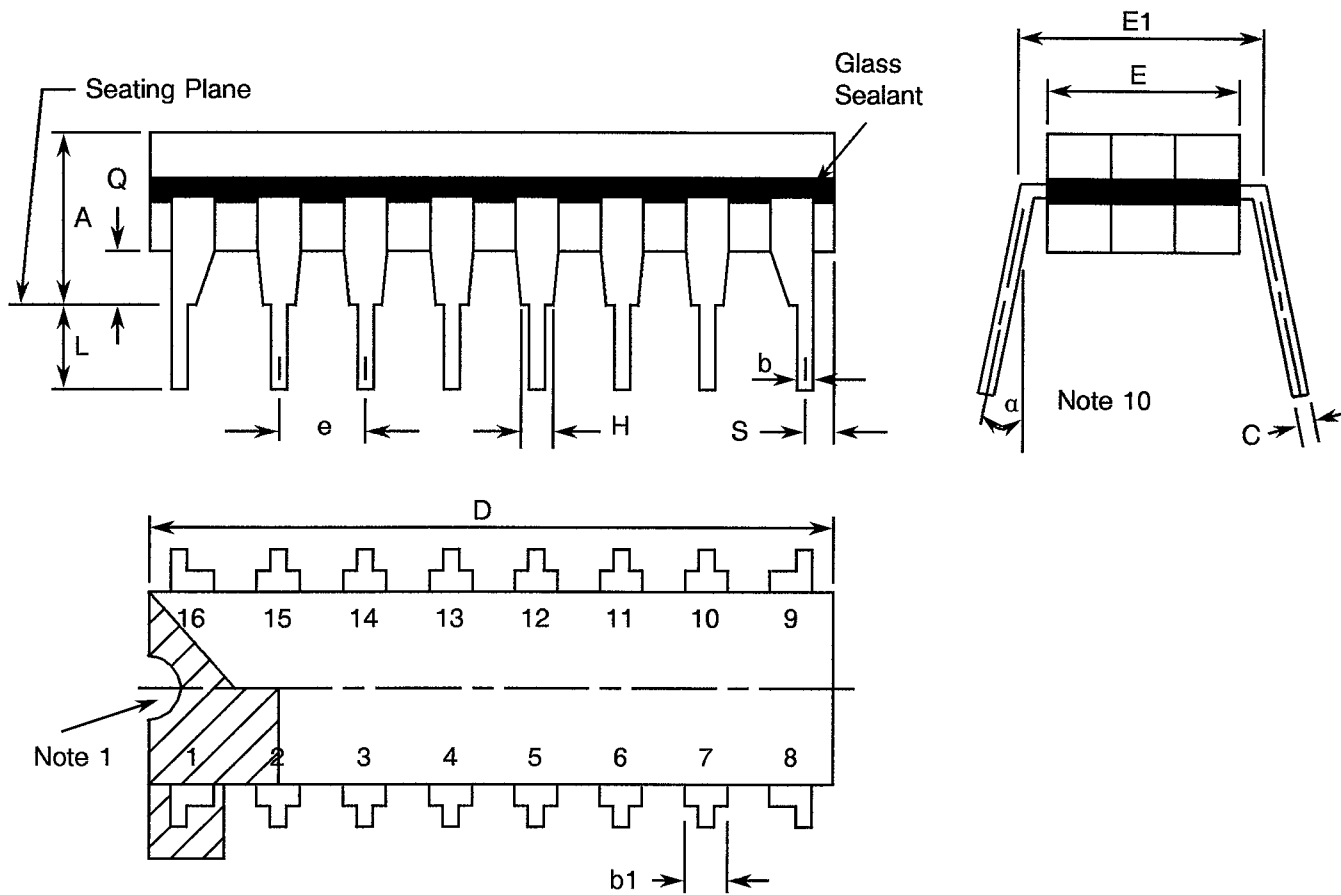

SYMBOL	MILLIMETRES		NOTES
	MIN	MAX	
A	-	5.08	
b	0.38	0.66	8
b1	-	1.78	8
C	0.20	0.44	8
D	19.18	19.94	4
E	6.22	7.62	4
E1	7.37	8.13	
e	2.54 TYPICAL		6, 9
F	1.27 TYPICAL		
H	0.76	-	
L	3.30	5.08	8
Q	0.51	-	3
S	0.38	1.27	7
alpha	0°	15°	10

NOTES: See Page 11.



FIGURE 2 - PHYSICAL DIMENSIONS (CONTINUED)

FIGURE 2(c) - DUAL-IN-LINE PACKAGE

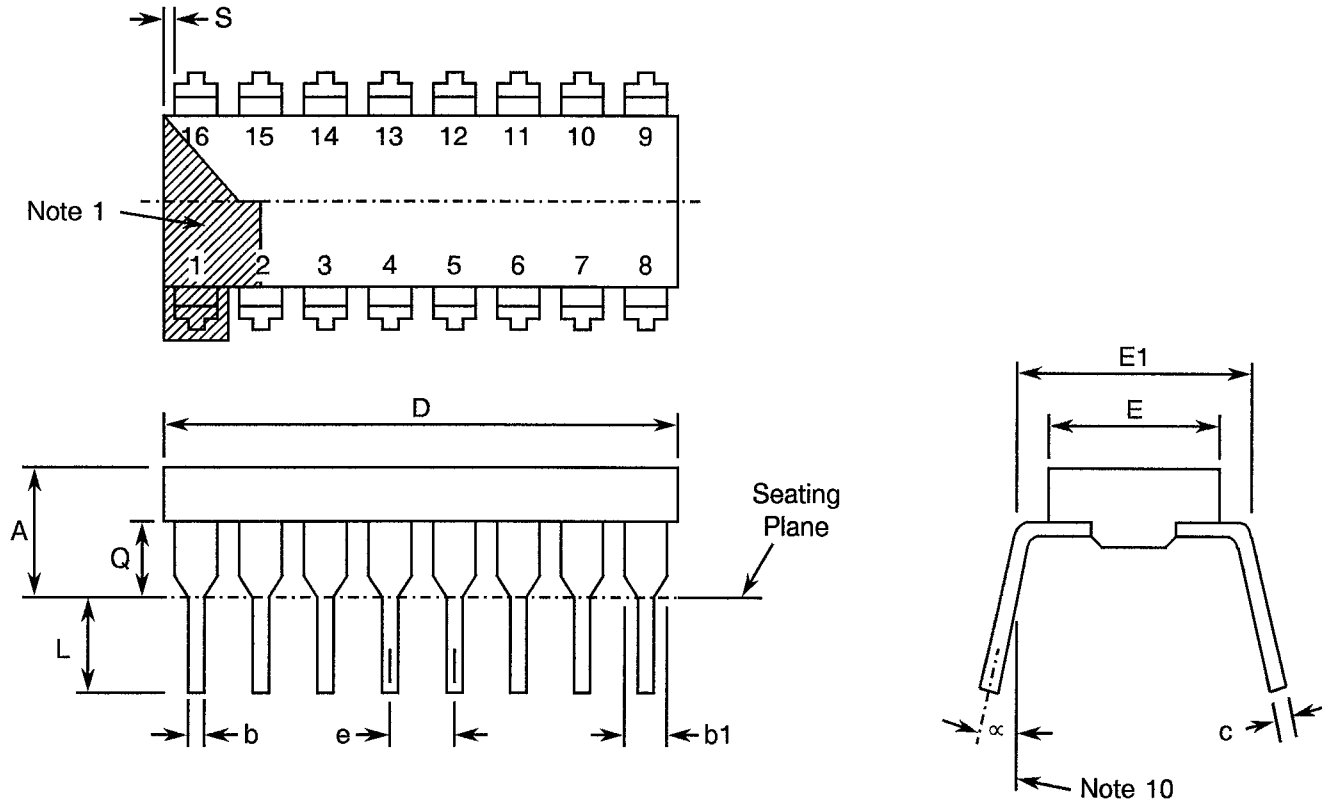

SYMBOL	MILLIMETRES		NOTES
	MIN.	MAX.	
A	-	5.08	-
b	0.36	0.58	8
b1	0.76	1.78	8
c	0.20	0.38	8
D	18.80	22.10	-
E	5.59	7.87	-
E1	7.37	8.13	4
e	2.54 TYPICAL		6, 9
L	3.18	5.08	-
Q	0.38	2.03	3
S	0.25	1.35	7
α	0°	15°	10

NOTES: See Page 11.



FIGURE 2 - PHYSICAL DIMENSIONS (CONTINUED)

FIGURE 2(d) - SQUARE CHIP CARRIER PACKAGE (3 LAYER BASE)

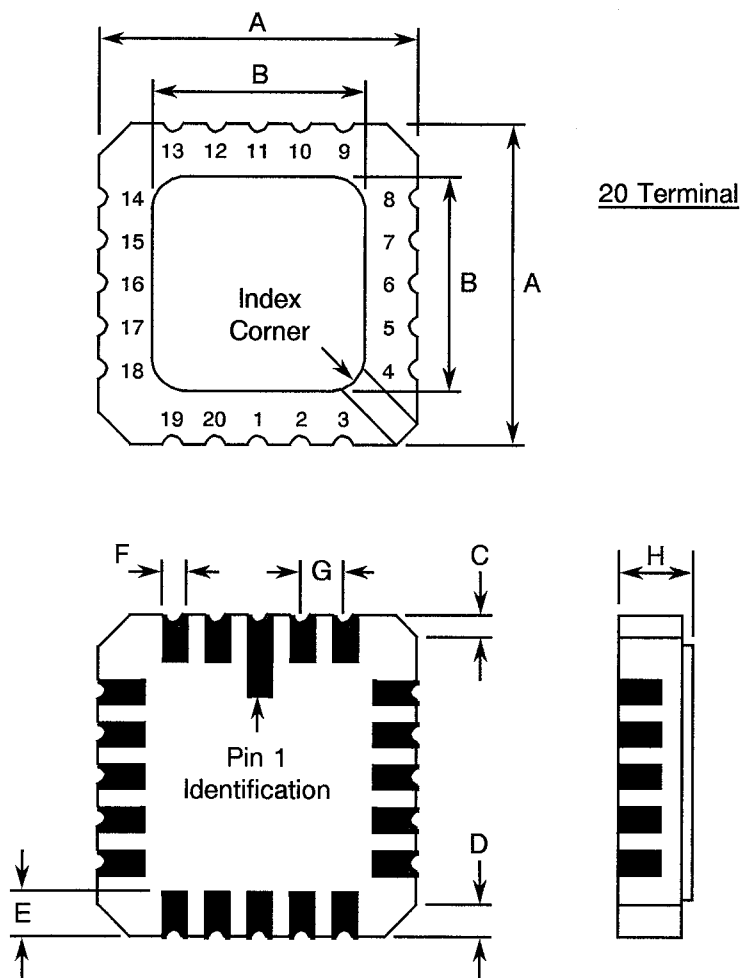

SYMBOL	MILLIMETRES		NOTES
	MIN.	MAX.	
A	8.687	9.093	-
B	7.798	9.093	-
C	0.250	0.510	11
D	0.889	1.143	12
E	1.140	1.400	8
F	0.559	0.712	8
G	1.27 TYPICAL		5, 9
H	1.630	2.540	-

NOTES: See Page 11.

**FIGURE 2 - PHYSICAL DIMENSIONS (CONTINUED)****NOTES TO FIGURES 2(a) TO 2(d)**

1. Index area: a notch or dot shall be located adjacent to Pin 1 and shall be within the shaded area shown. For chip carrier packages, the index shall be as shown in Figure 2(d).
2. Dimension Q shall be measured at the point of exit of the lead from the body.
3. Dimension Q shall be measured from the seating plane to the base plane.
4. This dimension allows for off-centre lids, meniscus and glass overrun.
5. The true position pin or terminal spacing is 1.27mm between centrelines. Each pin or terminal centreline shall be located within $\pm 0.13\text{mm}$ of its true longitudinal position relative to Pins 1 and the highest pin number.
6. The true position pin spacing is 2.54mm between centrelines. Each pin centreline shall be located within $\pm 0.25\text{mm}$ of its true longitudinal position relative to Pins 1 and the highest pin number.
7. Applies to all 4 corners.
8. All leads or terminals.
9. 14 spaces for flat and dual-in-line packages.
16 spaces for chip carrier packages.
10. Lead centre when α is 0° .
11. Index corner only - 2 dimensions.
12. 3 non-index corners - 6 dimensions.



FIGURE 3(a) - PIN ASSIGNMENT

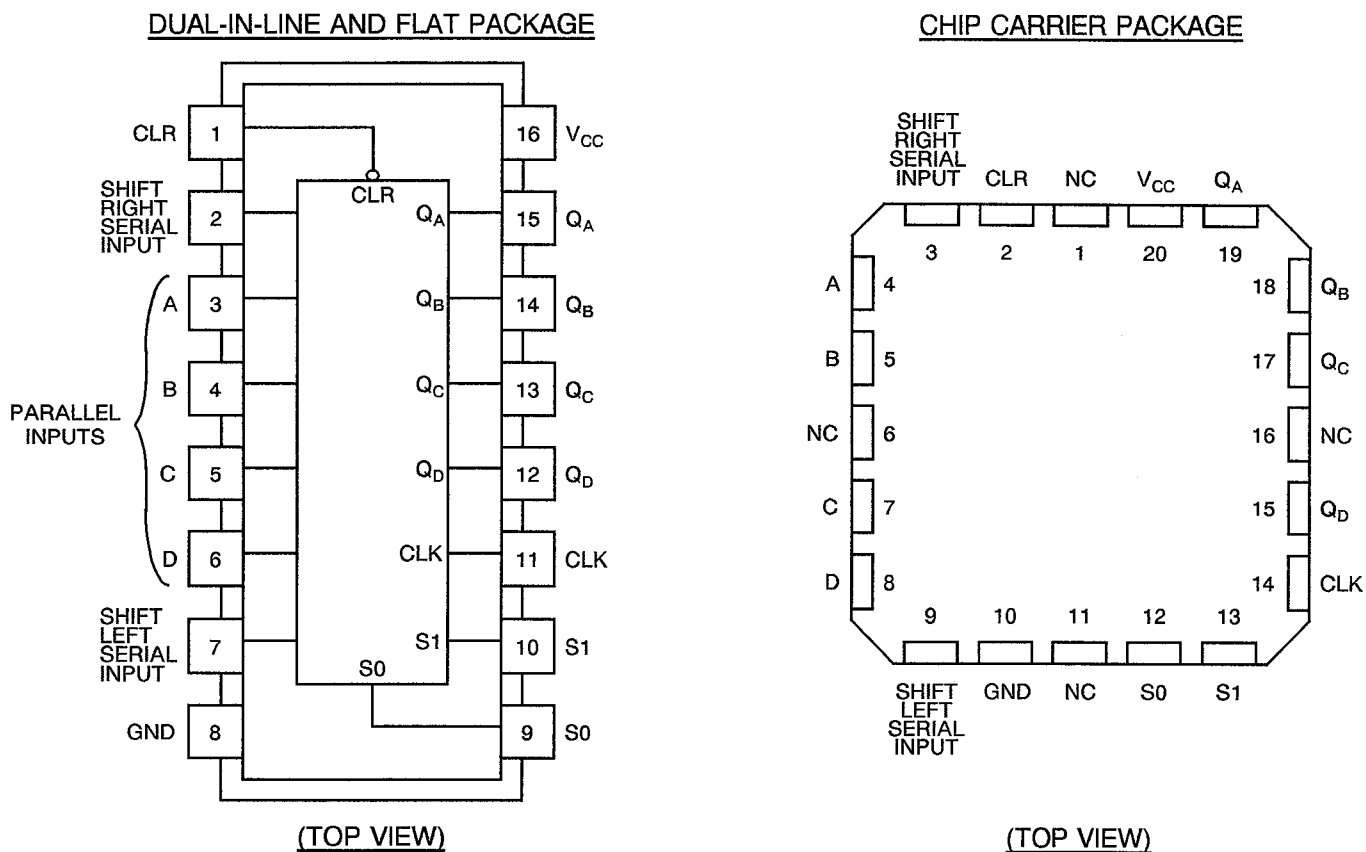

FLAT PACKAGE AND DUAL-IN-LINE TO CHIP CARRIER PIN ASSIGNMENT

FLAT PACKAGE AND DUAL-IN-LINE PIN OUTS	1	2	3	4	5	6	7	8	9	10	11	12	13	14	15	16
CHIP CARRIER PIN OUTS	2	3	4	5	7	8	9	10	12	13	14	15	17	18	19	20

NOTES

1. All references throughout this specification relate to FLAT/DIL packages only.



FIGURE 3(b) - TRUTH TABLE (FUNCTIONAL TABLE)

INPUTS										OUTPUTS			
CLEAR	MODE		CLOCK	SERIAL		PARALLEL				Q _A	Q _B	Q _C	Q _D
	S1	S0		LEFT	RIGHT	A	B	C	D				
L	X	X	X	X	X	X	X	X	X	L	L	L	L
H	X	X	L	X	X	X	X	X	X	Q _{A0}	Q _{B0}	Q _{C0}	Q _{D0}
H	H	H	↑	X	X	a	b	c	d	a	b	c	d
H	L	H	↑	X	H	X	X	X	X	H	Q _{An}	Q _{Bn}	Q _{Cn}
H	L	H	↑	X	L	X	X	X	X	L	Q _{An}	Q _{Bn}	Q _{Cn}
H	H	L	↑	H	X	X	X	X	X	Q _{Bn}	Q _{Cn}	Q _{Dn}	H
H	H	L	↑	L	X	X	X	X	X	Q _{Bn}	Q _{Cn}	Q _{Dn}	L
H	L	L	X	X	X	X	X	X	X	Q _{A0}	Q _{B0}	Q _{C0}	Q _{D0}

NOTES

1. Logic Level Definitions: L = Low Level, H = High Level, X = Don't Care.
2. ↑ = Transition from Low to High Level.
3. a,b,c,d = the level of steady state input at A, B, C or D respectively.
4. Q_{A0}, Q_{B0}, Q_{C0}, Q_{D0} = the level of Q_A, Q_B, Q_C, or Q_D respectively, before the indicated conditions were established.
5. Q_{An}, Q_{Bn}, Q_{Cn}, Q_{Dn} = the level of Q_A, Q_B, or Q_C respectively, before the most recent transition of the clock.

FIGURE 3(c) - CIRCUIT SCHEMATIC

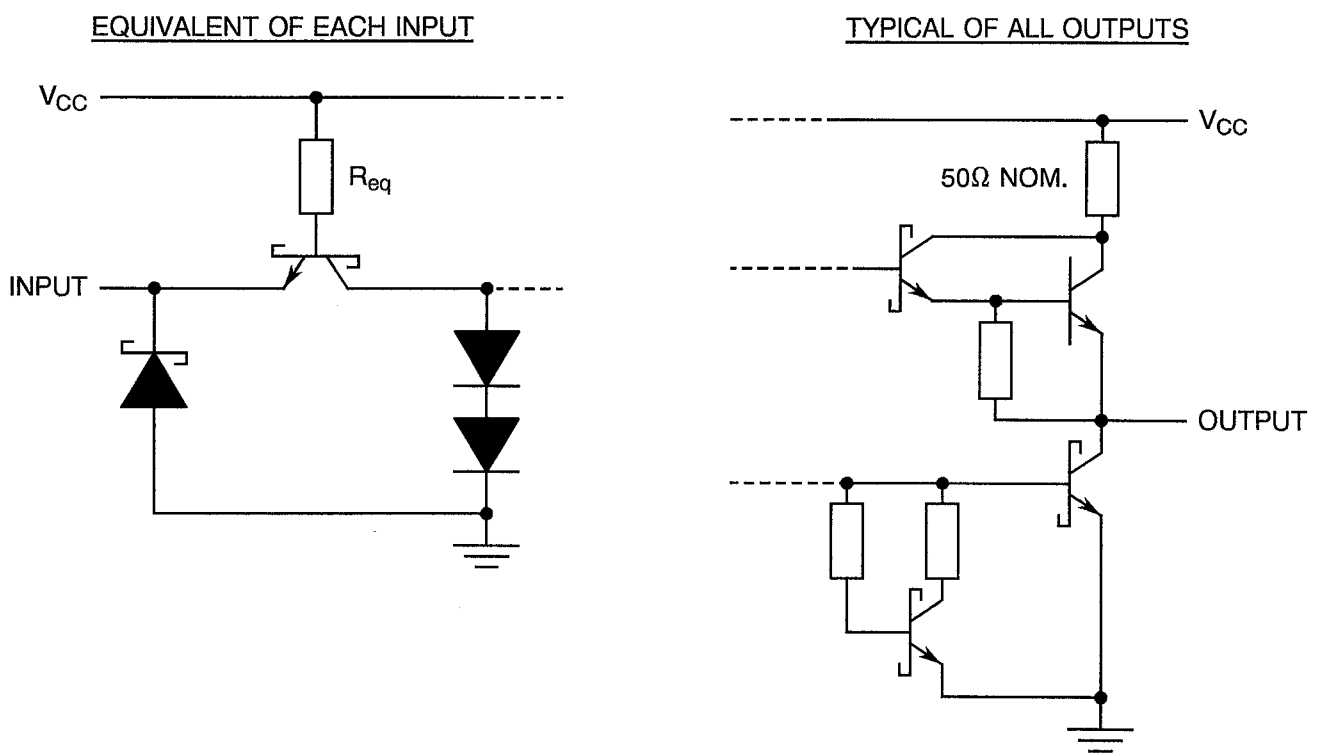
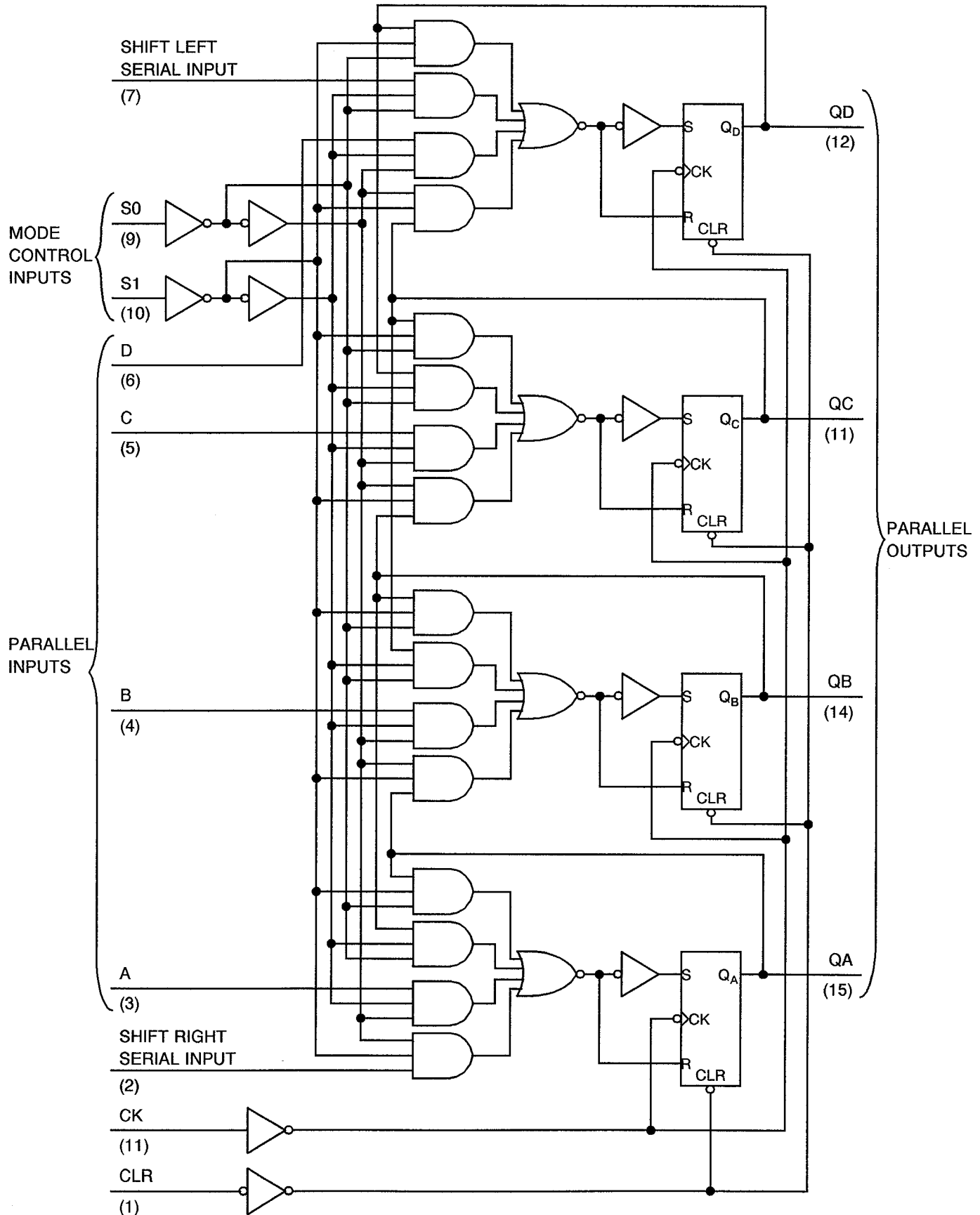



FIGURE 3(d) - FUNCTIONAL DIAGRAM



**2. APPLICABLE DOCUMENTS**

The following documents form part of this specification and shall be read in conjunction with it:-

- (a) ESA/SCC Generic Specification No. 9000 for Integrated Circuits.
- (b) MIL-STD-883, Test Methods and Procedures for Micro-electronics.

3. TERMS, DEFINITIONS, ABBREVIATIONS, SYMBOLS AND UNITS

For the purpose of this specification, the terms, definitions, abbreviations, symbols and units specified in ESA/SCC Basic Specification No. 21300 shall apply. In addition, the following abbreviations are used:-

- V_{IC} = Input Clamp Voltage.
- V_{CC} = Supply Voltage.

4. REQUIREMENTS**4.1 GENERAL**

The complete requirements for procurement of the integrated circuits specified herein are stated in this specification and ESA/SCC Generic Specification No. 9000 for Integrated Circuits. Deviations from the Generic Specification applicable to this specification only, are listed in Para. 4.2.

Deviations from the applicable Generic Specification and this Detail Specification, formally agreed with specific Manufacturers on the basis that the alternative requirements are equivalent to the ESA/SCC requirements and do not affect the components' reliability, are listed in the appendices attached to this specification.

4.2 DEVIATIONS FROM GENERIC SPECIFICATION**4.2.1 Deviations from Special In-process Controls**

None.

4.2.2 Deviations from Final Production Tests (Chart II)

None.

4.2.3 Deviations from Burn-in Tests (Chart III)

- (a) Para. 7.1.1(a), "High Temperature Reverse Bias" test and subsequent electrical measurements related to this test shall be omitted.
- (b) Para. 9.9.2, "Electrical Measurements at High and Low Temperatures": Only a test result summary, based on go-no-go tests and presented in histogram form is required.

4.2.4 Deviations from Qualification Tests (Chart IV)

None.

4.2.5 Deviations from Lot Acceptance Tests (Chart V)

None.



4.3 MECHANICAL REQUIREMENTS

4.3.1 Dimension Check

The dimensions of the integrated circuits specified herein shall be checked. They shall conform to those shown in Figure 2.

4.3.2 Weight

The maximum weight of the integrated circuits specified herein shall be 0.7 grammes for the flat package, 2.2 grammes for the dual-in-line package and 0.6 grammes for the chip carrier package.

4.4 MATERIALS AND FINISHES

The materials and finishes shall be as specified herein. Where a definite material is not specified, a material which will enable the integrated circuits specified herein to meet the performance requirements of this specification shall be used. Acceptance or approval of any constituent material does not guarantee acceptance of the finished product.

4.4.1 Case

The case shall be hermetically sealed and have a metal body with hard glass seals or a ceramic body and the lids shall be welded, brazed, preform-soldered or glass frit-sealed.

4.4.2 Lead Material and Finish

For dual-in-line and flat packages, the material shall be either Type 'D' or Type 'G' with either Type '3 or 4', Type '4' or Type '7' finish in accordance with the requirements of ESA/SCC Basic Specification No. 23500. For chip carrier packages, the finish shall be either Type '4' or Type '7' in accordance with the requirements of ESA/SCC Basic Specification No. 23500. (See Table 1(a) for Type Variants).

4.5 MARKING

4.5.1 General

The marking of all components delivered to this specification shall be in accordance with the requirements of ESA/SCC Basic Specification No. 21700. Each component shall be marked in respect of:-

- (a) Lead Identification.
- (b) The SCC Component Number.
- (c) Traceability Information.

4.5.2 Lead Identification

For dual-in-line and flat packages, an index shall be located at the top of the package in the position defined in Note 1 to Figure 2 or, alternatively, a tab may be used to identify Pin No. 1. The pin numbering must be read with the index or tab on the left-hand side. For chip carrier packages, the index shall be as defined by Figure 2(d).



4.5.3 The SCC Component Number

Each component shall bear the SCC Component Number which shall be constituted and marked as follows:

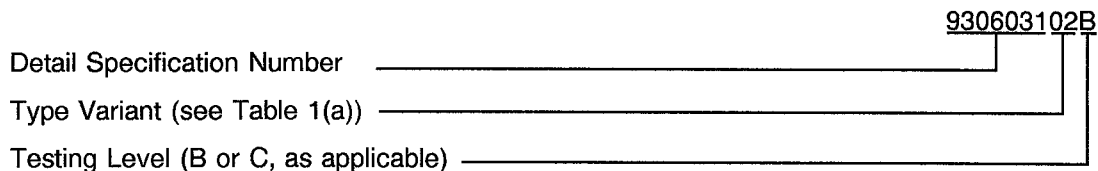

4.5.4 Traceability Information

Each component shall be marked in respect of traceability information in accordance with the requirements of ESA/SCC Basic Specification No. 21700.

4.6 ELECTRICAL MEASUREMENTS

4.6.1 Electrical Measurements at Room Temperature

The parameters to be measured in respect of electrical characteristics are scheduled in Table 2. Unless otherwise specified, the measurements shall be performed at $T_{amb} = +22 \pm 3$ °C.

4.6.2 Electrical Measurements at High and Low Temperatures

The parameters to be measured at high and low temperatures are scheduled in Table 3. The measurements shall be performed at $T_{amb} = +125$ and -55 °C respectively.

4.6.3 Circuits for Electrical Measurements

Circuits for use in performing the electrical measurements listed in Tables 2 and 3 of this specification are shown in Figure 4.

4.7 BURN-IN TESTS

4.7.1 Parameter Drift Values

The parameter drift values applicable to burn-in are specified in Table 4 of this specification. Unless otherwise stated, measurements shall be performed at $T_{amb} = +22 \pm 3$ °C. The parameter drift values (Δ) applicable to the parameters scheduled, shall not be exceeded. In addition to these drift value requirements, the appropriate limit value specified for a given parameter in Table 2 shall not be exceeded.

4.7.2 Conditions for Power Burn-in

The requirements for power burn-in are specified in Section 7 of ESA/SCC Generic Specification No. 9000. The conditions for power burn-in shall be as specified in Table 5 of this specification.

4.7.3 Electrical Circuits for Power Burn-in

Circuits for use in performing the power burn-in tests are shown in Figure 5 of this specification.

**TABLE 2 - ELECTRICAL MEASUREMENTS AT ROOM TEMPERATURE - D.C. PARAMETERS**

No.	CHARACTERISTICS	SYMBOL	TEST METHOD MIL-STD 883	TEST FIG.	TEST CONDITIONS (PINS UNDER TEST)	LIMITS		UNIT
						MIN	MAX	
1	Functional Test	-	-	3(b)	Verify Truth Table with Load. Note 1	-	-	-
2 to 11	Input Current High Level 1	I_{IH1}	3010	4(a)	$V_{CC} = 5.5V$, $V_{IN} = 2.7V$ (Pins 1-2-3-4-5-6-7-9-10-11)	-	50	μA
12 to 21	Input Current High Level 2 (Max. Input Voltage)	I_{IH2}	3010	4(a)	$V_{CC} = 5.5V$, $V_{IN} = 5.5V$ (Pins 1-2-3-4-5-6-7-9-10-11)	-	1.0	mA
22 to 31	Input Clamp Voltage	V_{IC}	3008	4(b)	$V_{CC} = 4.5V$, $I_{IN} = -18mA$ Note 2 (Pins 1-2-3-4-5-6-7-9-10-11)	-	-1.2	V
32 to 41	Input Current Low Level	I_{IL}	3009	4(c)	$V_{CC} = 5.5V$, $V_{IN} = 0.5V$ (Pins 1-2-3-4-5-6-7-9-10-11)	-	-2.0	mA
42 to 45	Output Voltage Low Level	V_{OL}	3007	4(d)	$V_{CC} = 4.5V$, $V_{IL} = 0.8V$ $V_{IH} = 2.0V$, $I_{OL} = 20mA$ (Pins 12-13-14-15)	-	0.5	V
46 to 49	Output Voltage High Level	V_{OH}	3006	4(e)	$V_{CC} = 4.5V$, $V_{IL} = 0.8V$ $V_{IH} = 2.0V$, $I_{OH} = -1.0mA$ (Pins 12-13-14-15)	2.5	-	V
50 to 53	Short Circuit Output Current	I_{OS}	3011	4(f)	$V_{CC} = 5.5V$ Note 3 (Pins 12-13-14-15)	-40	-100	mA
54	Supply Current	I_{CC}	3005	4(g)	$V_{CC} = 5.5V$ Note 4 (Pin 16)	-	110	mA

NOTES: See Page 19.

**TABLE 2 - ELECTRICAL MEASUREMENTS AT ROOM TEMPERATURE - A.C. PARAMETERS**

No.	CHARACTERISTICS	SYMBOL	TEST METHOD MIL-STD 883	TEST FIG.	TEST CONDITIONS (PINS UNDER TEST) (NOTE 5)	LIMITS		UNIT
						MIN	MAX	
55 to 58	Propagation Delay, Low to High Level, from Clock to Output	t _{PLH}	3003	4(h)	V _{CC} = 5.0V R _L = 280Ω C _L = 15pF (Pins 12-13-14-15)	-	12	ns
59 to 62	Propagation Delay, High to Low Level, from Clock to Output	t _{PHL1}	3003	4(h)	V _{CC} = 5.0V R _L = 280Ω C _L = 15pF (Pins 12-13-14-15)	-	17	ns
63 to 66	Propagation Delay, High to Low Level, from Clear to Output	t _{PHL2}	3003	4(h)	V _{CC} = 5.0V R _L = 280Ω C _L = 15pF (Pins 12-13-14-15)	-	19	ns

NOTES

1. Go-no-go test with V_{IL} = 0.3V, V_{IH} = 3.0V, V_{CC} = 5.0V; trip point 1.5V.
2. All inputs and outputs not under test shall be open.
3. No more than 1 output should be shorted at a time, and only for 1 second maximum.
4. With all outputs open and 4.5V applied to all Data and Clear inputs, I_{CC} is measured after a momentary ground, then 4.5V is applied to Clock.
5. Propagation delay measurements shall be performed as a go-no-go test on a 100% basis. Read-and-record measurements shall be performed on an LTPD7 sample basis following the Chart III Burn-in Test.

**TABLE 3 - ELECTRICAL MEASUREMENTS AT HIGH AND LOW TEMPERATURES,
+ 125(+ 0 - 5) °C AND - 55(+ 5 - 0) °C**

No.	CHARACTERISTICS	SYMBOL	TEST METHOD MIL-STD 883	TEST FIG.	TEST CONDITIONS (PINS UNDER TEST)	LIMITS		UNIT
						MIN	MAX	
1	Functional Test	-	-	3(b)	Verify Truth Table with Load. Note 1	-	-	-
2 to 11	Input Current High Level 1	I_{IH1}	3010	4(a)	$V_{CC} = 5.5V$, $V_{IN} = 2.7V$ (Pins 1-2-3-4-5-6-7-9-10-11)	-	50	μA
12 to 21	Input Current High Level 2 (Max. Input Voltage)	I_{IH2}	3010	4(a)	$V_{CC} = 5.5V$, $V_{IN} = 5.5V$ (Pins 1-2-3-4-5-6-7-9-10-11)	-	1.0	mA
22 to 31	Input Clamp Voltage	V_{IC}	3008	4(b)	$V_{CC} = 4.5V$, $I_{IN} = -18mA$ Note 2 (Pins 1-2-3-4-5-6-7-9-10-11)	-	-1.2	V
32 to 41	Input Current Low Level	I_{IL}	3009	4(c)	$V_{CC} = 5.5V$, $V_{IN} = 0.5V$ (Pins 1-2-3-4-5-6-7-9-10-11)	-	-2.0	mA
42 to 45	Output Voltage Low Level	V_{OL}	3007	4(d)	$V_{CC} = 4.5V$, $V_{IL} = 0.8V$ $V_{IH} = 2.0V$, $I_{OL} = 20mA$ (Pins 12-13-14-15)	-	0.5	V
46 to 49	Output Voltage High Level	V_{OH}	3006	4(e)	$V_{CC} = 4.5V$, $V_{IL} = 0.8V$ $V_{IH} = 2.0V$, $I_{OH} = -1.0mA$ (Pins 12-13-14-15)	2.5	-	V
50 to 53	Short Circuit Output Current	I_{OS}	3011	4(f)	$V_{CC} = 5.5V$ Note 3 (Pins 12-13-14-15)	-40	-100	mA
54	Supply Current	I_{CC}	3005	4(g)	$V_{CC} = 5.5V$ Note 4 (Pin 16)	-	110	mA

NOTES: See Page 19.



FIGURE 4 - CIRCUITS FOR ELECTRICAL MEASUREMENTS

FIGURE 4(a) - HIGH LEVEL INPUT CURRENT

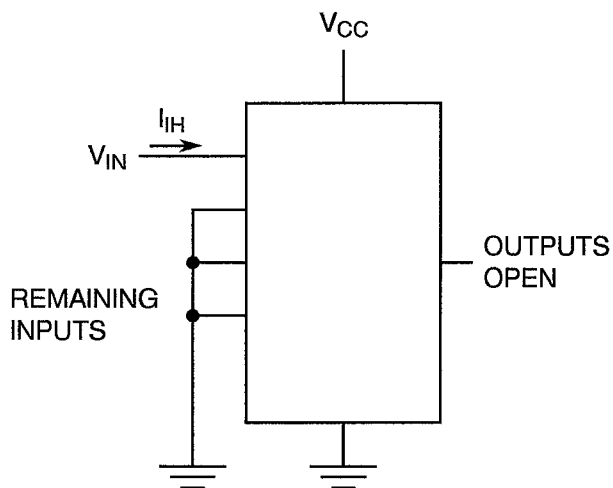

NOTES

- 1. Each input to be tested separately.

FIGURE 4(b) - INPUT CLAMP VOLTAGE

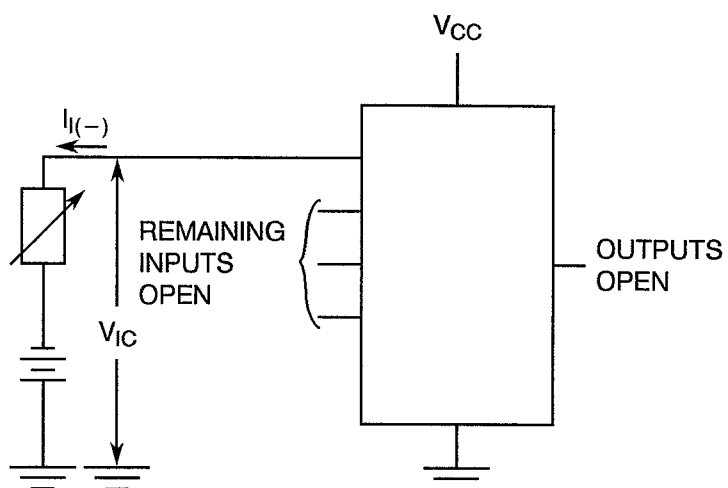

NOTES

- 1. Each input to be tested separately.

FIGURE 4(c) - LOW LEVEL INPUT CURRENT

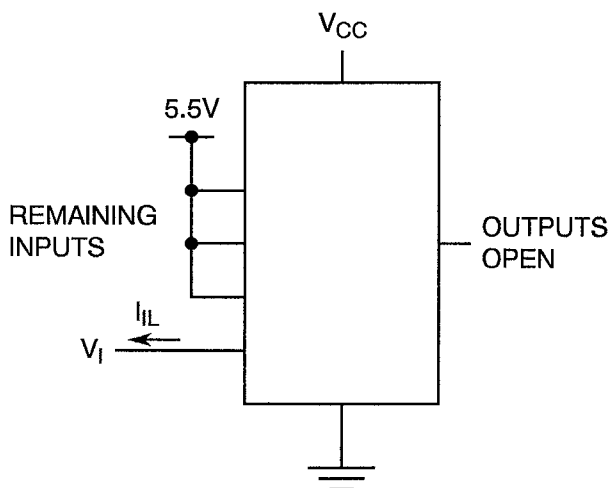

NOTES

- 1. Each input to be tested separately.

FIGURE 4(d) - LOW LEVEL OUTPUT VOLTAGE

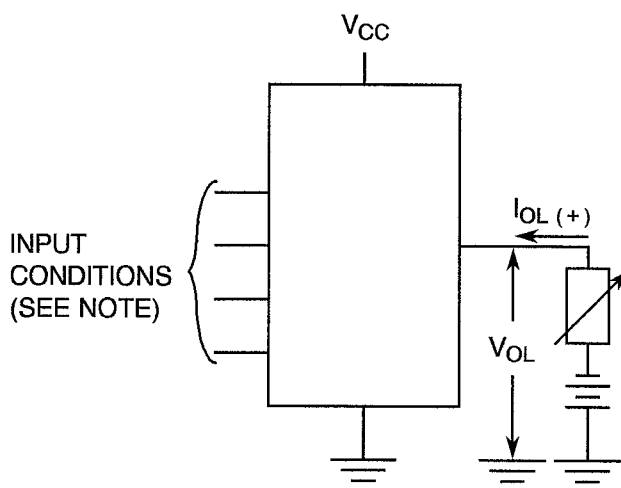

NOTES

- 1. Test per Truth Table.



FIGURE 4 - CIRCUITS FOR ELECTRICAL MEASUREMENTS (CONTINUED)

FIGURE 4(e) - HIGH LEVEL OUTPUT VOLTAGE

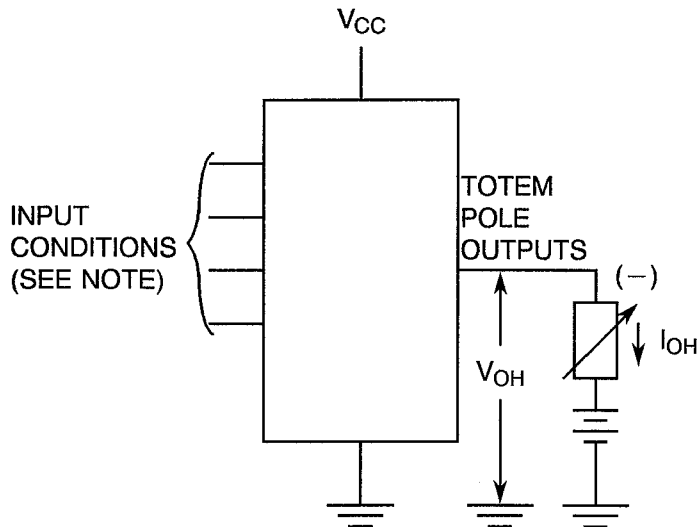

NOTES

- 1. Test per Truth Table.

FIGURE 4(f) - SHORT CIRCUIT OUTPUT CURRENT

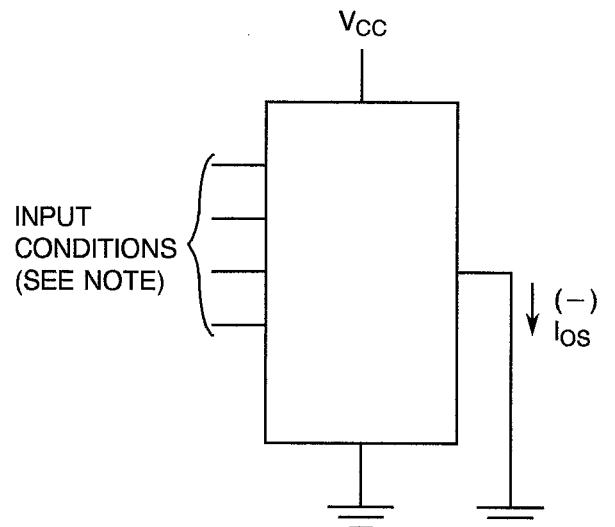

NOTES

- 1. Test Per Truth Table.
- 2. No more than one output should be shorted at a time.
- 3. Inputs and data inputs corresponding to outputs under test = 4.5V; other data inputs = 0V.

Apply input pulse

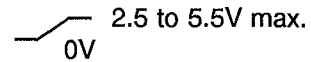

to Clock and Clear

FIGURE 4(g) - SUPPLY CURRENT

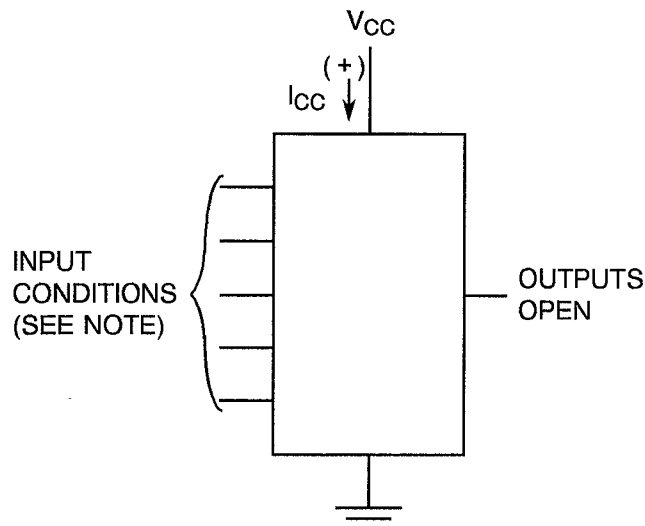

NOTES

- 1. See Note 4 to Table 2.



FIGURE 4 - CIRCUITS FOR ELECTRICAL MEASUREMENTS (CONTINUED)

FIGURE 4(h) - DYNAMIC TEST AND SWITCHING WAVEFORMS

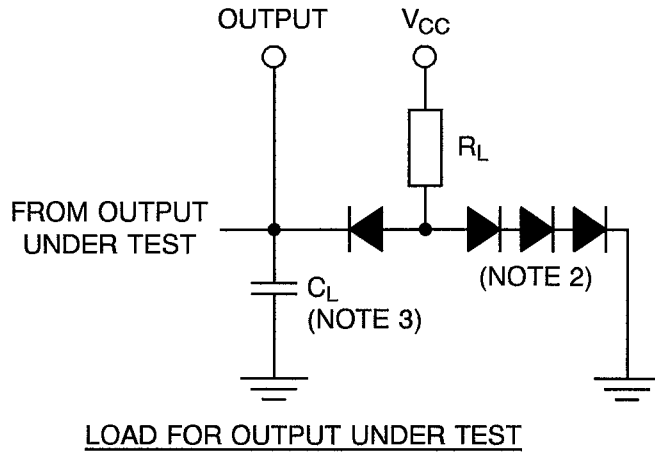

TEST TABLE FOR SYNCHRONOUS INPUTS

DATA INPUT FOR TEST	S1	S0	OUTPUT TESTED (NOTE 6)
A	4.5V	4.5V	QA at t_{n+1}
B	4.5V	4.5V	QB at t_{n+1}
C	4.5V	4.5V	QC at t_{n+1}
D	4.5V	4.5V	QD at t_{n+1}
L Serial Input	4.5V	0V	QA at t_{n+4}
R Serial Input	0V	4.5V	QD at t_{n+4}

VOLTAGE WAVEFORMS

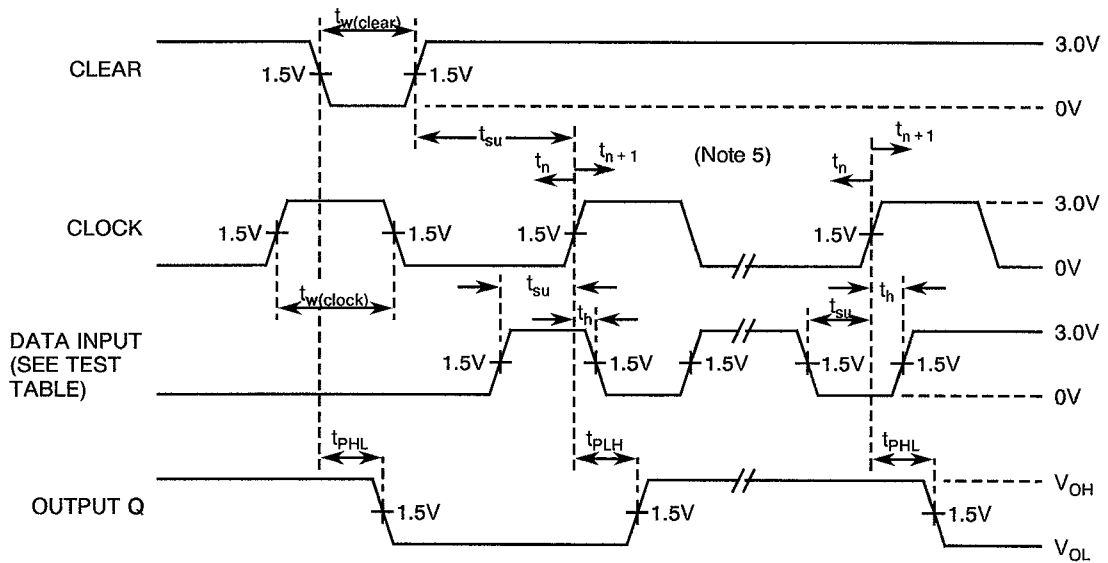

NOTES

- The clock pulse generator has the following characteristics: $Z_{OUT} = 50\Omega$, $PRR < 1.0\text{MHz}$, $t_r < 2.5\text{ns}$ and $t_f < 2.5\text{ns}$.
- All diodes are 1N916 or 1N3064.
- $C_L = 15\text{pF}$ and includes probe and jig capacitance.
- A Clear pulse is applied prior to each test.
- Propagation delay times (t_{PLH} and t_{PHL}) are measured at t_{n+1} . Proper shifting of data is verified at t_{n+4} with a functional test.
- t_n = bit time before clocking transition.
 t_{n+1} = bit time after 1 clocking transition.
 t_{n+4} = bit time after 4 clocking transitions.

**TABLE 4 - PARAMETER DRIFT VALUES**

No.	CHARACTERISTICS	SYMBOL	SPEC. AND/OR TEST METHOD	TEST CONDITIONS	CHANGE LIMITS (Δ)	UNIT
2 to 11	Input Current High Level 1	I_{IH1}	As per Table 2	As per Table 2	± 20 or (1) ± 10	% μA
32 to 41	Input Current Low Level	I_{IL}	As per Table 2	As per Table 2	± 200	μA
42 to 45	Output Voltage Low Level	V_{OL}	As per Table 2	As per Table 2	± 60	mV
46 to 49	Output Voltage High Level	V_{OH}	As per Table 2	As per Table 2	± 240	mV

NOTES

1. Whichever is greater, referred to the initial value.

TABLE 5 - CONDITIONS FOR POWER BURN-IN AND OPERATING LIFE TEST

No.	CHARACTERISTICS	SYMBOL	CONDITION	UNIT
1	Ambient Temperature	T_{amb}	+ 125(+ 0 - 5)	$^{\circ}C$
2	Power Supply Voltage	V_{CC}	5(+ 0.5 - 0)	V
3	Pulse Voltage	V_{GEN}	0.5 max. to 3.0 min.	V
4	Frequency	f_{GEN1} f_{GEN2}	100 50 (Note 1)	Hz
5	Fan-out	-	10	-
6	Rise Time	t_r	50 max.	μs
7	Fall Time	t_f	50 max.	μs
8	Duty Cycle	-	20 min.	%

NOTES

1. Tolerance $\pm 10\%$.



FIGURE 5 - ELECTRICAL CIRCUIT FOR POWER BURN-IN AND OPERATING LIFE TEST

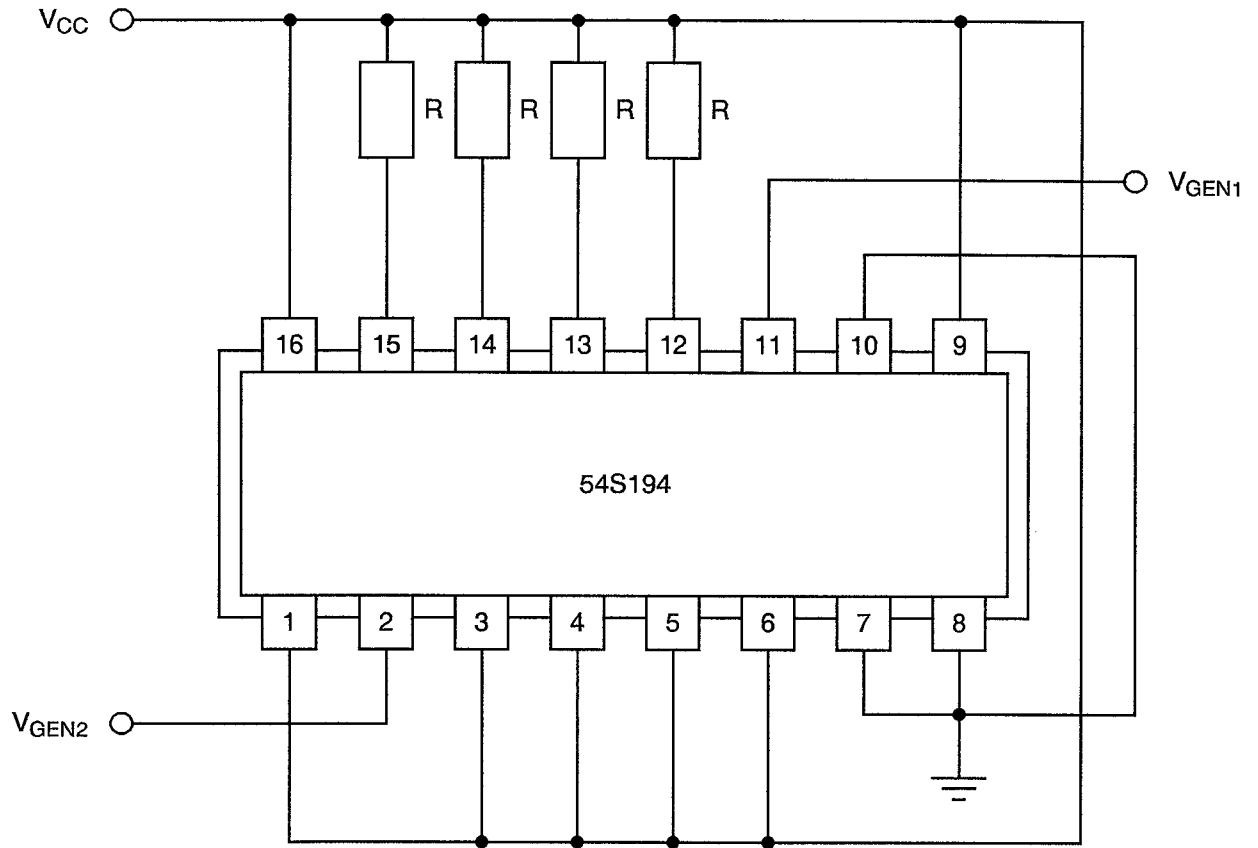

NOTES

- 1. $R = 220\Omega$.



4.8 ENVIRONMENTAL AND ENDURANCE TESTS (CHARTS IV AND V OF ESA/SCC GENERIC SPECIFICATION NO. 9000)

4.8.1 Electrical Measurements on Completion of Environmental Tests

The parameters to be measured on completion of environmental tests are scheduled in Table 6. Unless otherwise stated, the measurements shall be performed at $T_{amb} = +22 \pm 3$ °C.

4.8.2 Electrical Measurements at Intermediate Points during Endurance Tests

The parameters to be measured at intermediate points during endurance tests are as scheduled in Table 6 of this specification. Unless otherwise stated, the measurements shall be performed at $T_{amb} = +22 \pm 3$ °C.

4.8.3 Electrical Measurements on Completion of Endurance Tests

The parameters to be measured on completion of endurance testing are as scheduled in Table 6 of this specification. Unless otherwise stated, the measurements shall be performed at $T_{amb} = +22 \pm 3$ °C.

4.8.4 Conditions for Operating Life Tests

The requirements for operating life testing are specified in Section 9 of ESA/SCC Generic Specification No. 9000. The conditions for operating life testing shall be as specified in Table 5 of this specification.

4.8.5 Electrical Circuits for Operating Life Tests

Circuits for use in performing the operating life tests are shown in Figure 5 of this specification.

4.8.6 Conditions for High Temperature Storage Test

The requirements for the high temperature storage test are specified in ESA/SCC Generic Specification No. 9000. The conditions for high temperature storage shall be $T_{amb} = +150(+0-5)$ °C.

**TABLE 6 - ELECTRICAL MEASUREMENTS ON COMPLETION OF ENVIRONMENTAL TESTS AND AT INTERMEDIATE POINTS AND ON COMPLETION OF ENDURANCE TESTS**

No.	CHARACTERISTICS	SYMBOL	SPEC. AND/OR TEST METHOD	TEST CONDITIONS	CHANGE LIMITS		UNIT
					(Δ)	ABSOLUTE	
2 to 11	Input Current High Level 1	I_{IH1}	As per Table 2	As per Table 2	± 10	-	μA
12 to 21	Input Current High Level 2 (Max. Input Voltage)	I_{IH2}	As per Table 2	As per Table 2	-	1.0	mA
32 to 41	Input Current Low Level	I_{IL}	As per Table 2	As per Table 2	± 200	-	μA
42 to 45	Output Voltage Low Level	V_{OL}	As per Table 2	As per Table 2	± 60	-	mV
46 to 49	Output Voltage High Level	V_{OH}	As per Table 2	As per Table 2	± 240	-	mV
54	Supply Current	I_{CC}	As per Table 2	As per Table 2	± 20	-	%

**SCC**ESA/SCC Detail Specification
No. 9306/031

PAGE 28

ISSUE 2

APPENDIX 'A'Page 1 of 1**AGREED DEVIATIONS FOR TEXAS INSTRUMENTS (F)**

ITEMS AFFECTED	DESCRIPTION OF DEVIATIONS
Para. 4.2.1	Scanning Electron Microscope (SEM) Inspection may be performed using TIF document TIF 3.61.610.001.
Para. 4.2.2	Prior to Die Shear Test TIF may perform a Radiographic Inspection on the randomly chosen samples to be subjected to this test, using TIF document TIF 50.42-3002.
Para. 4.2.3	Radiographic Inspection may be performed using TIF document TIF 50.42-3002.