



Pages 1 to 40

ELECTROMECHANICAL SWITCHES

ESCC Generic Specification No. 3701

| | |
|---------|---------------|
| Issue 2 | December 2007 |
|---------|---------------|



Document Custodian: European Space Agency - see <https://escies.org>

LEGAL DISCLAIMER AND COPYRIGHT

European Space Agency, Copyright © 2007. All rights reserved.

The European Space Agency disclaims any liability or responsibility, to any person or entity, with respect to any loss or damage caused, or alleged to be caused, directly or indirectly by the use and application of this ESCC publication.

This publication, without the prior permission of the European Space Agency and provided that it is not used for a commercial purpose, may be:

- copied in whole, in any medium, without alteration or modification.
- copied in part, in any medium, provided that the ESCC document identification, comprising the ESCC symbol, document number and document issue, is removed.

DOCUMENTATION CHANGE NOTICE

(Refer to <https://escies.org> for ESCC DCR content)

| DCR No. | CHANGE DESCRIPTION |
|----------|---|
| 240, 364 | Specification upissued to incorporate editorial, technical changes as per DCRs. |

TABLE OF CONTENTS

| | | |
|------------------|--|------------------|
| <u>1.</u> | <u>INTRODUCTION</u> | <u>8</u> |
| 1.1 | Scope | 8 |
| 1.2 | Applicability | 8 |
| <u>2.</u> | <u>APPLICABLE DOCUMENTS</u> | <u>8</u> |
| 2.1 | ESCC Specifications | 8 |
| 2.2 | Other (Reference) Documents | 8 |
| 2.3 | Order of Precedence | 9 |
| <u>3.</u> | <u>TERMS, DEFINITIONS, ABBREVIATIONS, SYMBOLS AND UNITS</u> | <u>9</u> |
| <u>4.</u> | <u>REQUIREMENTS</u> | <u>9</u> |
| 4.1 | General | 9 |
| 4.1.1 | Specifications | 9 |
| 4.1.2 | Conditions and Methods of Test | 10 |
| 4.1.3 | Manufacturer's Responsibility for Performance of Tests and Inspections | 10 |
| 4.1.4 | Inspection Rights | 10 |
| 4.1.5 | Pre-encapsulation Inspection | 10 |
| 4.2 | Qualification Approval Requirements on a Manufacturer | 10 |
| 4.3 | Deliverable Components | 10 |
| 4.3.1 | Lot Failure | 10 |
| 4.3.2 | Testing and Lot Acceptance Levels | 11 |
| 4.4 | Marking | 11 |
| 4.5 | Materials and Finishes | 11 |
| <u>5.</u> | <u>PRODUCTION CONTROL</u> | <u>11</u> |
| 5.1 | General | 11 |
| 5.2 | Special In-process Controls | 11 |
| 5.2.1 | Supplementary Components | 12 |
| 5.2.2 | Documentation | 12 |
| <u>6.</u> | <u>FINAL PRODUCTION CONTROL</u> | <u>13</u> |
| 6.1 | General | 13 |
| 6.2 | Test Methods and Conditions | 13 |
| 6.3 | Documentation | 13 |
| <u>7.</u> | <u>SCREENING AND ELECTRICAL MEASUREMENTS</u> | <u>13</u> |
| 7.1 | General | 13 |
| 7.1.1 | Conditions of Test | 13 |
| 7.1.2 | Data Points | 13 |
| 7.2 | Failure Criteria | 14 |
| 7.2.1 | Parameter Drift Failure | 14 |
| 7.2.2 | Parameter Limit Failure | 14 |
| 7.2.3 | Other Failures | 14 |
| 7.3 | Failed Components | 14 |
| 7.4 | Lot Failure | 14 |
| 7.4.1 | Lot Failure during 100% Testing | 14 |
| 7.4.2 | Lot Failure during Sample Testing | 14 |
| 7.5 | Documentation | 15 |
| <u>8.</u> | <u>QUALIFICATION APPROVAL AND LOT ACCEPTANCE TESTS</u> | <u>15</u> |
| 8.1 | Qualification Testing | 15 |

| | | |
|-----------|---|------------------|
| 8.1.1 | General | 15 |
| 8.1.2 | Distribution within the Qualification Test Lot | 15 |
| 8.2 | Lot Acceptance Testing | 15 |
| 8.2.1 | General | 15 |
| 8.2.2 | Distribution within the Sample for Lot Acceptance Testing | 15 |
| 8.2.3 | Lot Acceptance Level 3 Testing (LA3) | 16 |
| 8.2.4 | Lot Acceptance Level 2 Testing (LA2) | 16 |
| 8.2.5 | Lot Acceptance Level 1 Testing (LA1) | 16 |
| 8.3 | Failure Criteria | 16 |
| 8.3.1 | Environmental and Mechanical Test Failures | 16 |
| 8.3.2 | Electrical Failures | 17 |
| 8.3.3 | Other Failures | 17 |
| 8.4 | Failed Components | 17 |
| 8.5 | Lot Failure | 17 |
| 8.6 | Documentation | 17 |
| 9. | <u>TEST METHODS AND PROCEDURES</u> | <u>21</u> |
| 9.1 | Internal Visual Inspection | 22 |
| 9.2 | Functional Test | 22 |
| 9.3 | Operating Characteristics | 22 |
| 9.4 | Electrical Measurements | 22 |
| 9.4.1 | General | 22 |
| 9.4.1.1 | Contact Resistance | 22 |
| 9.4.1.2 | Contact Bounce Times | 22 |
| 9.4.1.3 | Voltage Proof | 24 |
| 9.4.1.4 | Insulation Resistance | 24 |
| 9.4.2 | Parameter Drift Value Measurements | 24 |
| 9.4.3 | Electrical Measurements at High and Low Temperatures | 25 |
| 9.4.4 | Electrical Measurements at Room Temperature | 25 |
| 9.4.5 | Electrical Measurements during Endurance Testing | 25 |
| 9.5 | Dimension Check | 25 |
| 9.6 | Seal Test | 25 |
| 9.6.1 | Gross Leak | 25 |
| 9.6.2 | Fine Leak (for Hermetically Sealed Devices) | 25 |
| 9.7 | External Visual Inspection | 25 |
| 9.8 | Rapid Change of Temperature | 26 |
| 9.9 | Vibration | 26 |
| 9.9.1 | Mounting | 26 |
| 9.9.2 | Procedure | 26 |
| 9.9.3 | Electrical Conditions | 26 |
| 9.9.4 | Failure | 26 |
| 9.9.5 | Final Inspection | 26 |
| 9.10 | Shock | 26 |
| 9.10.1 | Mounting | 26 |
| 9.10.2 | Procedure | 26 |
| 9.10.3 | Electrical Conditions | 27 |
| 9.10.4 | Failure | 27 |
| 9.10.5 | Final Inspection and Measurements | 27 |
| 9.11 | Mechanical Measurements | 27 |
| 9.11.1 | Robustness of Terminations | 27 |
| 9.11.2 | Strength of Mounting Bushing | 27 |
| 9.11.3 | Strength of Actuator | 27 |
| 9.11.3.1 | Toggle Switches | 27 |
| 9.11.3.2 | Sensitive Switches | 28 |

| | | |
|------------|---|-----------|
| 9.11.4 | Travels and Forces (for Sensitive Switches) | 28 |
| 9.12 | Damp Heat | 28 |
| 9.12.1 | Procedure | 28 |
| 9.12.2 | Final Inspection and Measurements | 28 |
| 9.13 | Current Carrying Capability | 28 |
| 9.13.1 | Procedure | 28 |
| 9.13.2 | Final Inspection and Measurements | 29 |
| 9.14 | Operating Life | 29 |
| 9.14.1 | Resistive Endurance Test | 29 |
| 9.14.2 | Inductive Endurance Test | 29 |
| 9.14.3 | Capacitive Endurance Test | 30 |
| 9.15 | Temperature Rise | 30 |
| 9.15.1 | Mounting | 31 |
| 9.15.2 | Ambient Test Temperature | 31 |
| 9.15.3 | Electrical Conditions | 31 |
| 9.15.4 | Measurements | 31 |
| 9.15.5 | Limit | 31 |
| 9.16 | Resistance to Soldering Heat | 31 |
| 9.16.1 | Procedure | 31 |
| 9.16.2 | Final Inspection and Measurements | 32 |
| 9.17 | Solderability | 32 |
| 9.17.1 | Procedure | 32 |
| 9.17.2 | Final Examination | 32 |
| 9.18 | Permanence of Marking | 32 |
| 9.19 | Final Assembly | 32 |
| 9.20 | Low Level Life | 32 |
| 9.20.1 | Low Level Life during Qualification Testing | 32 |
| 9.20.2 | Low Level Life during Lot Acceptance Testing | 33 |
| 9.21 | Run-In | 33 |
| 9.22 | Overload | 34 |
| 9.22.1 | Procedure | 34 |
| 9.22.2 | Final Inspection | 34 |
| 10. | <u>DATA DOCUMENTATION</u> | 34 |
| 10.1 | General | 34 |
| 10.1.1 | Qualification Approval | 34 |
| 10.1.2 | Testing Level B | 34 |
| 10.1.2.1 | Qualified Components | 34 |
| 10.1.2.2 | Unqualified Components | 35 |
| 10.1.3 | Testing Level C | 35 |
| 10.1.4 | Data Retention/Data Access | 35 |
| 10.2 | Cover Sheet(s) | 35 |
| 10.3 | List of Equipment Used | 35 |
| 10.4 | List of Test References | 35 |
| 10.5 | Special In-Process Control Data | 36 |
| 10.6 | Final Production Test Data (CHART II) | 36 |
| 10.7 | Screening and Electrical Measurement Data (CHART III) | 36 |
| 10.7.1 | Testing Level B | 36 |
| 10.7.2 | Testing Level C | 36 |
| 10.8 | Qualification Test Data (CHART IV) | 36 |
| 10.9 | Lot Acceptance Test Data (CHART V) | 37 |
| 10.9.1 | Testing Level B | 37 |
| 10.9.2 | Testing Level C | 37 |
| 10.10 | Failed Component List and Failure Analysis Report | 37 |



| | | |
|-------------------|--------------------------------------|------------------|
| 10.11 | Certificate of Conformity | 37 |
| <u>11.</u> | <u>DELIVERY</u> | <u>37</u> |
| <u>12.</u> | <u>PACKAGING AND DESPATCH</u> | <u>37</u> |
| APPENDIX A | | 38 |

1. INTRODUCTION

1.1 SCOPE

This specification defines the general requirements for the qualification approval, procurement, including lot acceptance testing, and delivery of Electromechanical Switches for space applications.

This specification contains the appropriate inspection and test schedules and also specifies the data documentation requirements.

1.2 APPLICABILITY

This specification is primarily applicable to the granting of qualification approval to a component in accordance with ESCC Basic Specification No. 20100 and the procurement of such components from qualified Manufacturers.

2. APPLICABLE DOCUMENTS

The following documents form part of, and shall be read in conjunction with, this specification. The relevant issues shall be those in effect on the date of placing the Purchase Order.

2.1 ESCC SPECIFICATIONS

| | |
|------------|---|
| No. 20100, | Requirements for the Qualification of Standard Electronic Components for Space Application. |
| No. 20400, | Internal Visual Inspection. |
| No. 20500, | External Visual Inspection. |
| No. 20600, | Preservation, Packaging and Despatch of ESCC Electronic Components. |
| No. 20900, | Radiographic Inspection. |
| No. 21300, | Terms, Definitions, Abbreviations, Symbols and Units. |
| No. 21700, | General Requirements for the Marking of ESCC Components. |
| No. 22800, | ESCC Non-conformance Control System. |
| No. 23500, | Lead Materials and Finishes for Components for Space Application. |
| No. 24600, | Minimum Quality System Requirements |
| No. 24800, | Resistance to Solvents of Marking, Materials and Finishes. |

With the exception of ESCC Basic Specifications Nos. 20100, 21700, 22800 and 24600, where Manufacturers' specifications are equivalent to, or more stringent than, the ESCC Basic Specifications listed above, they may be used in place of the latter, subject to the approval of the ESCC Executive.

Such replacements shall be clearly identified in the applicable Process Identification Document (PID) and listed in an appendix to the appropriate Detail Specification.

Unless otherwise stated herein, references within the text of this specification to "the Detail Specification" shall mean the relevant ESCC Detail Specification.

2.2 OTHER (REFERENCE) DOCUMENTS

IEC Publication No. 60068 Part 2, Basic Environmental Testing Procedures.

IEC Publication No. 60410, Sampling Plans and Procedures for Inspection by Attributes.

MIL-STD-202, Test Method Standard, Electronic and Electrical Component Parts..

ECSS-Q-70-02, Thermal Vacuum Test for the Screening of Space Materials.

2.3 ORDER OF PRECEDENCE

For the purpose of interpretation and in case of conflict with regard to documentation, the following order of precedence shall apply:-

- (a) ESCC Detail Specification
- (b) ESCC Generic Specification
- (c) ESCC Basic Specification
- (d) Other documents, if referenced herein

3. TERMS, DEFINITIONS, ABBREVIATIONS, SYMBOLS AND UNITS

The terms, definitions, abbreviations, symbols and units specified in ESCC Basic Specification No. 21300 shall apply. The following terms shall apply in this specification:-

- Hermetically sealed components
Components sealed, metal encased with either separately fabricated headers or terminals or both. This grade does not include units which are encapsulated in a metal shell with an opening in either end or side of the shell, or with insulated lead wires extending through the metal shell. They are resistant to the moisture-resistance, immersion and fine leak tests.
- Waterproof components
Components intended to be mounted on a front panel and to provide a water-tightness. They are not resistance to the moisture-resistance, immersion and fine leak tests.

4. REQUIREMENTS

4.1 GENERAL

The test requirements for qualification approval of a component shall comprise final production tests (Chart II), screening and electrical measurements to testing level B (Chart III) and qualification testing (Chart IV).

The test requirements for procurement of components shall comprise final production tests (Chart II), screening and electrical measurements to testing level B (Chart III) together with, when applicable, a level of lot acceptance testing (Chart V) to be specified by the Orderer.

If a Manufacturer elects to eliminate a final production test by substituting an in-process control or statistical process control procedure, the Manufacturer is still responsible for delivering components that meet all of the performance, quality and reliability requirements defined in this specification and the Detail Specification.

4.1.1 Specifications

For qualification approval, procurement (including lot acceptance testing) and delivery of components in conformity with this specification, the specifications listed in Section 2 of this document shall apply in total unless otherwise specified herein or in the Detail Specification.

4.1.2 Conditions and Methods of Test

The conditions and methods of test shall be in accordance with this specification, the ESCC Basic Specifications referenced herein and the Detail Specification.

4.1.3 Manufacturer's Responsibility for Performance of Tests and Inspections

The Manufacturer shall be responsible for the performance of tests and inspections required by the applicable specifications. These tests and inspections shall be performed at the plant of the Manufacturer of the components unless it is agreed by the ESCC Executive prior to commencing qualification testing, or procurement, to use an approved external facility.

4.1.4 Inspection Rights

The ESCC Executive (for qualification approval or for a procurement) reserves the right to monitor any of the tests and inspections scheduled in the applicable specifications.

4.1.5 Pre-encapsulation Inspection

The Manufacturer shall notify the Orderer at least 2 working weeks before the commencement of pre-encapsulation inspection.

The Orderer shall indicate immediately whether or not he intends to witness the inspection.

4.2 QUALIFICATION APPROVAL REQUIREMENTS ON A MANUFACTURER

To obtain and maintain the qualification approval of a component, or family of components, a Manufacturer shall satisfy the requirements of ESCC Basic Specification No. 20100.

4.3 DELIVERABLE COMPONENTS

Components delivered to this specification shall be processed and inspected in accordance with the relevant Process Identification Document (PID). Each delivered component shall be traceable to its production lot. Components delivered to this specification shall have completed satisfactorily all tests to the testing level and lot acceptance level specified in the Purchase Order (see Para. 4.3.2).

ESCC qualified components delivered to this specification shall be produced from lots that are capable of passing all tests, and sequences of tests, that are defined in Charts IV and V. The Manufacturer shall not knowingly supply components that cannot meet this requirement. In the event that, subsequent to delivery and prior to operational use, a component is found to be in a condition such that it could not have passed these tests at the time of manufacture, this shall be grounds for rejection of the delivered lot.

4.3.1 Lot Failure

Lot failure may occur during final production tests (Chart II), screening and electrical measurements (Chart III), qualification testing (Chart IV) or lot acceptance testing (Chart V).

Should such failure occur, the non-conformance procedure shall be initiated in accordance with ESCC Basic Specification No. 22800.

Should such failure occur during procurement, the Manufacturer shall notify the Orderer by any appropriate written means within 2 working days, giving details of the number and mode of failure and the suspected cause.

In the case where qualification approval has been granted to the component, he shall, at the same time by the same means, inform the ESCC Executive in order that the latter may consider its implications.

No further testing shall be performed on the failed components except on instruction from the Orderer.

The Orderer shall inform the Manufacturer and the ESCC Executive within 2 working days of receipt of the communication, by the same means, what action shall be taken.

In the case when lot failure occurs during qualification testing, the Manufacturer shall immediately notify the ESCC Executive who will define a course of action to be followed. No further testing shall be performed on the failed components.

4.3.2 Testing and Lot Acceptance Levels

This specification defines 1 level of testing severity which is designated by the letter B (see Chart I) and 3 levels of lot acceptance testing (see Chart V).

The lot acceptance levels are designated 1, 2 and 3 and are comprised of tests as follows:-

| | |
|-----------------|--|
| Level 3 (LA3) - | Electrical Subgroup |
| Level 2 (LA2) - | Endurance Subgroup, plus Electrical Subgroup |
| Level 1 (LA1) - | Environmental and Mechanical Subgroup, plus Endurance Subgroup, plus Electrical Subgroup |

The required testing level and lot acceptance level shall both be specified in a Purchase Order.

4.4 MARKING

All components procured and delivered to this specification from a source qualified according to ESCC Basic Specification No. 20100 shall be marked in accordance with ESCC Basic Specification No. 21700. Thus, they shall bear the ESA symbol to signify their conformance to the ESCC qualification approval requirements and full compliance with the requirements of this specification and the Detail Specification.

Components procured from sources which are not ESCC qualified, provided that they fully comply with the procurement requirements of this specification and the Detail Specification, may bear the ESCC marking **with the exception of the ESA symbol**.

4.5 MATERIALS AND FINISHES

All non-metallic materials and finishes that are not within a hermetically sealed enclosure, of the components specified herein shall meet the outgassing requirements as outlined in ECSS-Q-70-02.

Specific requirements for materials and finishes are specified in the Detail Specification.

5. PRODUCTION CONTROL

5.1 GENERAL

The minimum requirements for production control, which are equally applicable to procurement, are defined in ESCC Basic Specification No. 20100, Para's 6.1 and 6.2.

5.2 SPECIAL IN-PROCESS CONTROLS

Where applicable, special in-process controls shall apply as specified in the Detail Specification.

5.2.1 Supplementary Components

Supplementary components shall, wherever possible, be obtained from ESCC qualified sources. Procurement controls for supplementary components shall be agreed with the ESCC Executive and form part of the PID.

5.2.2 Documentation

Documentation of special in-process controls shall be in accordance with the requirements of Para. 10.5 of this specification.

CHART I - TESTING LEVELS

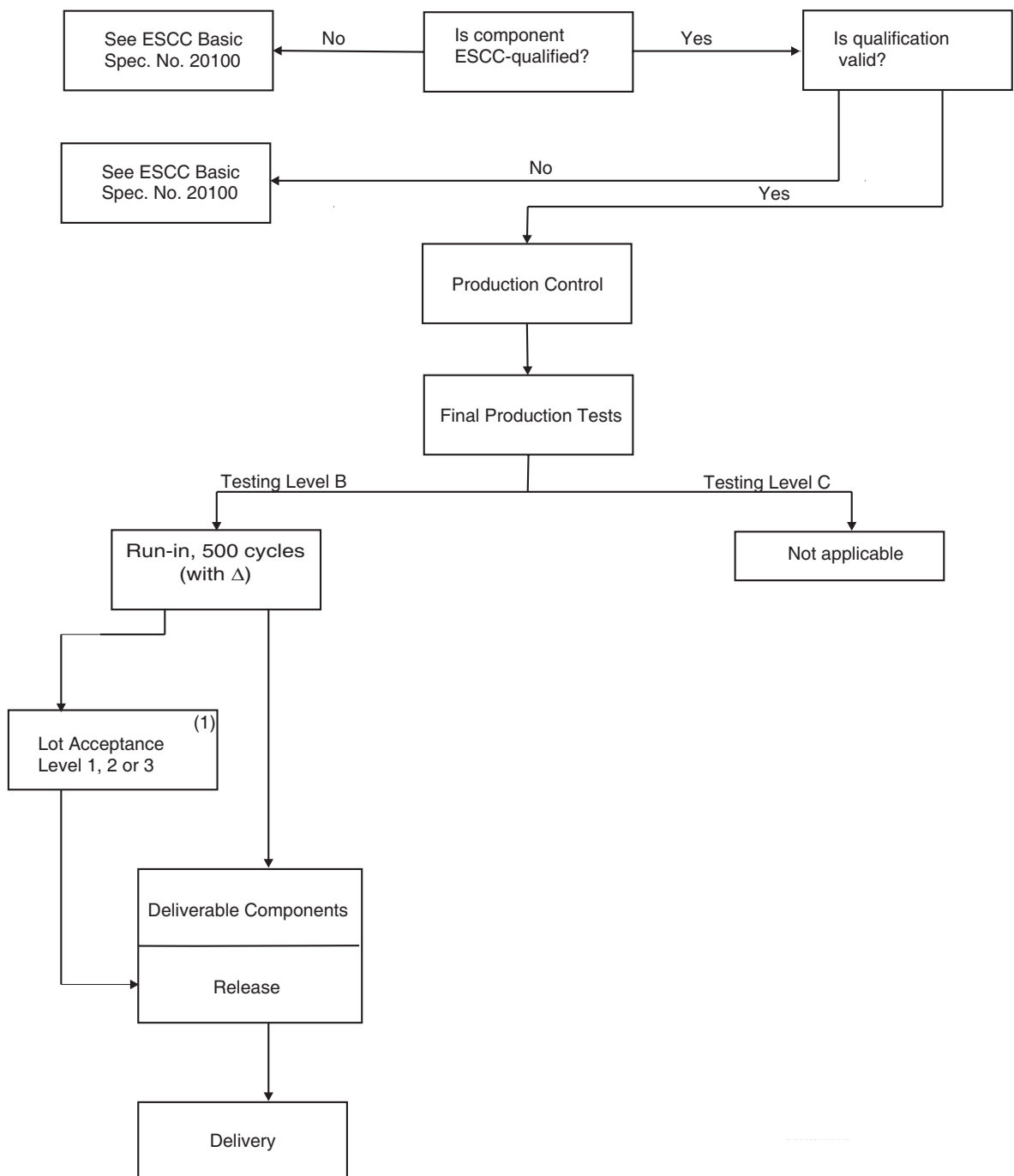

NOTES:

1. When applicable.

6. FINAL PRODUCTION CONTROL**6.1 GENERAL**

Unless otherwise specified in the Detail Specification, all components used for qualification testing and all components for delivery, including those submitted to lot acceptance tests, shall be subjected to tests and inspections in accordance with Chart II.

Unless otherwise specified in the Detail Specification, the tests shall be performed in the order shown.

Any components that do not meet these requirements shall be removed from the lot and at no future time be re-submitted to the requirements of this specification.

6.2 TEST METHODS AND CONDITIONS

The applicable test methods and conditions are specified in the paragraphs referenced in Chart II of this specification.

6.3 DOCUMENTATION

Documentation of final production test data shall be in accordance with the requirements of Para. 10.6 of this specification.

7. SCREENING AND ELECTRICAL MEASUREMENTS**7.1 GENERAL**

Unless otherwise specified in the Detail Specification, all components used for qualification testing and all components for delivery, including those submitted to lot acceptance tests, shall be subjected to tests and inspections in accordance with Chart III.

Unless otherwise specified in the Detail Specification, the tests shall be performed in the order shown.

The applicable test methods and conditions are specified in the paragraphs referenced in Chart III.

Components of testing level B shall be serialised prior to the tests and inspections.

7.1.1 Conditions of Test

The conditions for run-in shall be as shown in Table 5 of the Detail Specification. For the applicable test methods and procedures, see Para. 9.21.

7.1.2 Data Points

For components of testing level B, undergoing a total run-in period of 500 cycles, the data points for parameter drift measurement shall be 0 cycles (initial) and 500 cycles (final).

7.2 FAILURE CRITERIA

7.2.1 Parameter Drift Failure

The acceptable delta limits are shown in Table 4 of the Detail Specification. A component of testing level B shall be counted as a parameter drift failure if the changes during run-in are larger than the delta (Δ) values specified.

7.2.2 Parameter Limit Failure

A component shall be counted as a limit failure if one or more parameters exceed the limits shown in Tables 2 or 3 of the Detail Specification.

Any component which exhibits a limit failure prior to the screening sequence shall be rejected and not counted when determining lot rejection.

7.2.3 Other Failures

A component shall be counted as a failure in any of the following cases:

- Mechanical failure.
- Handling failure.
- Lost component.

7.3 FAILED COMPONENTS

A component shall be considered as a failed component if it exhibits one or more of the failure modes described in Para. 7.2 of this specification.

7.4 LOT FAILURE

In case of lot failure, the Manufacturer shall act in accordance with the requirements of Para. 4.3.1 of this specification.

7.4.1 Lot Failure during 100% Testing

If the number of components failed on the basis of the failure criteria described in Para. 7.2 exceeds 5% (rounded upwards to the nearest whole number) of the number of components submitted to screening and electrical measurements, the lot shall be considered as failed.

If a lot is composed of groups of components of one family defined in one ESCC Detail Specification, but separately identifiable for any reason, then the lot failure criteria shall apply separately to each identifiable group.

7.4.2 Lot Failure during Sample Testing

A lot shall be considered as failed if the number of allowable failures during sample testing, in accordance with General Inspection Level II of IEC Publication No. 60410 and the applicable AQL as specified in the Detail Specification, is exceeded.

In the case where an LTPD is specified in the Detail Specification, a lot shall be considered as failed if the number of failures allowed is exceeded (see Appendix A for LTPD Sampling Plan).

If a lot failure occurs in either case, a 100% testing may be performed with the lot failure criteria given in Para. 7.4.1.

7.5 DOCUMENTATION

Data documentation of screening and electrical measurements shall be in accordance with Para. 10.7 of this specification.

8. QUALIFICATION APPROVAL AND LOT ACCEPTANCE TESTS

8.1 QUALIFICATION TESTING

8.1.1 General

Qualification testing shall be in accordance with the requirements of Chart IV of this specification. The tests to Chart IV shall be performed on the specified sample, chosen at random from components which have successfully passed the tests in Charts II and III for Testing Level B. This sample constitutes the qualification test lot.

The qualification test lot is divided into subgroups of tests and all components assigned to a subgroup shall be subjected to all of the tests in that subgroup, in the sequence shown.

The applicable test requirements are detailed in the paragraphs referenced in Chart IV.

The conditions governing qualification testing are given in ESCC Basic Specification No. 20100, Para. 6.3 and, for the extension or renewal of qualification approval, in Para's 7.3 and 7.4.

8.1.2 Distribution within the Qualification Test Lot

Where an ESCC Detail specification covers a range or series of components that are considered similar, then the qualification test lot shall be comprised of component types so selected that they adequately represent all of the various mechanical, structural and electrical peculiarities of that range or series.

The selected distribution shall be agreed with the ESCC Executive.

8.2 LOT ACCEPTANCE TESTING

8.2.1 General

The sample sizes of the 3 lot acceptance levels are specified in Chart V. All components assigned to a subgroup shall be subjected to all of the tests of that subgroup in the sequence shown.

The tests to Chart V shall be performed on the specified sample which shall have been chosen, whenever possible, at random from the proposed delivery lot (but see Para. 8.2.3(b)). The applicable test requirements are detailed in the paragraphs referenced in Chart V.

As a minimum for procurement of non-qualified components, lot acceptance level 3 tests shall apply. For procurement of qualified components, lot acceptance testing shall be performed if specified in a Purchase Order. Procurement lots ordered with a lot acceptance test level shall be delivered only after successful completion of lot acceptance testing.

8.2.2 Distribution within the Sample for Lot Acceptance Testing

Where a Detail Specification covers a range or series of components that are considered similar, then it may be necessary that the sample for lot acceptance testing be comprised of component types so selected that they adequately represent all of the various mechanical, structural and electrical peculiarities of the procured range or series.

The distribution of the component types will normally vary from procurement to procurement and shall be as specified by the Orderer, following as closely as possible the requirements prescribed in Para. 8.1.2 of this specification.

8.2.3 Lot Acceptance Level 3 Testing (LA3)

Lot acceptance level 3 tests are designated as the electrical subgroup and comprise electrical measurements of characteristics and tests to prove the assembly capability of the component. For LA3 testing, the following requirements and conditions shall apply:-

- (a) LA3 testing shall be performed by the Manufacturer's quality assurance personnel using dedicated quality assurance equipment whenever possible. LA3 testing shall not be a repetition of routine measurements made by production personnel during final production tests and burn-in and electrical measurements.
- (b) When tests to Tables 2 and 3 of the Detail Specification have been performed on a sample basis, then the components for LA3 testing shall be selected from this sample.
- (c) The electrical measurements for LA3 are considered to be non-destructive and therefore components so tested may form part of the delivery lot.
- (d) When required in the Purchase Order, the Manufacturer shall notify the Orderer at least 2 working weeks before the commencement of LA3 testing. The Orderer shall indicate immediately whether or not he intends to witness the tests.

8.2.4 Lot Acceptance Level 2 Testing (LA2)

Lot acceptance level 2 testing shall comprise the tests for LA3 (electrical subgroup) plus tests on an endurance subgroup. For the electrical subgroup, the requirements and conditions as for LA3 (see Para. 8.2.3) shall apply.

For the endurance subgroup, the following shall apply:-

- (a) The tests in this subgroup are considered to be destructive and therefore components (of testing level B) so tested shall not form part of the delivery lot.

8.2.5 Lot Acceptance Level 1 Testing (LA1)

Lot acceptance level 1 testing shall comprise the tests for LA3 (electrical subgroup) and LA2 (endurance subgroup) plus tests on an environmental and mechanical subgroup. For the electrical and endurance subgroups, the requirements and conditions for LA3 (see Para. 8.2.3) and LA2 (see Para. 8.2.4) respectively shall apply.

For the environmental subgroup, the following shall apply:-

- (a) The tests in this subgroup are considered to be destructive and therefore components (of testing level B) so tested shall not form part of the delivery lot.

8.3 FAILURE CRITERIA

The following criteria shall apply to qualification testing and to lot acceptance testing.

8.3.1 Environmental and Mechanical Test Failures

The following shall be counted as component failures:

- Components which fail during tests for which the pass/fail criteria are inherent in the test method, e.g.

seal, solderability, robustness of terminations, etc.

8.3.2 Electrical Failures

The following shall be counted as component failures:-

- (a) Components which, when subjected to electrical measurements on completion of environmental tests, in accordance with either Table 2 or Table 6, as specified in the Detail Specification, fail one or more of the applicable limits.
- (b) Components which, when subjected to electrical measurements at intermediate and end-points during endurance testing, in accordance with Table 6 of the Detail Specification, fail one or more of the applicable limits.
- (c) Components which, when subjected to measurement of electrical characteristics, in accordance with Tables 2 and 3 of the Detail Specification, fail one or more of the applicable limits.

8.3.3 Other Failures

The following additional failures may also occur during qualification testing or lot acceptance testing:-

- (a) Components failing to comply with the requirements of ESCC Basic Specification No. 20500.
- (b) Lost components.

8.4 FAILED COMPONENTS

A component shall be considered as failed if it exhibits one or more of the failure modes detailed in Para. 8.3 of this specification. The allowable number of failed components per subgroup, the aggregate failure constraints and the permitted distribution of such failures are shown at the foot of Charts IV and V of this specification.

When requested by the ESCC Executive or the Orderer, failure analysis of failed components shall be performed by the Manufacturer and the results provided.

Failed components from successful lots shall be marked as such and be stored at the Manufacturer's plant for 24 months.

8.5 LOT FAILURE

A lot shall be considered as failed if the allowable number of failures according to Chart IV or V of this specification, as relevant, has been exceeded.

In the case of lot failure, the Manufacturer shall act in accordance with Para. 4.3.1 of this specification.

8.6 DOCUMENTATION

For qualification testing, the qualification test data shall be documented in accordance with the requirements of Para. 10.8 of this specification.

In the case of lot acceptance testing, the data shall be documented in accordance with the requirements of Para. 10.9.

CHART II - FINAL PRODUCTION TESTS

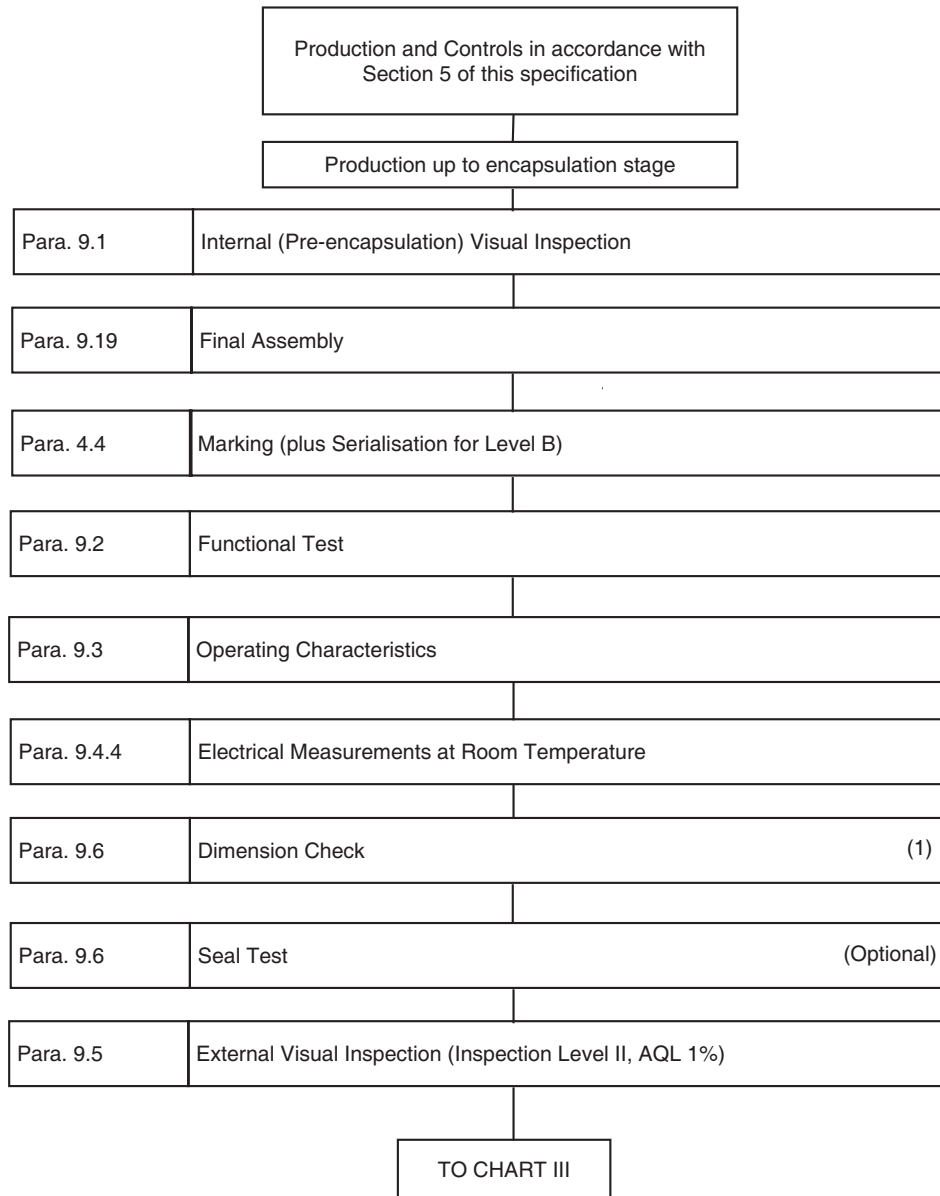

NOTES:

1. This test may take place at a different stage of the sequence.

CHART III - SCREENING AND ELECTRICAL MEASUREMENTS

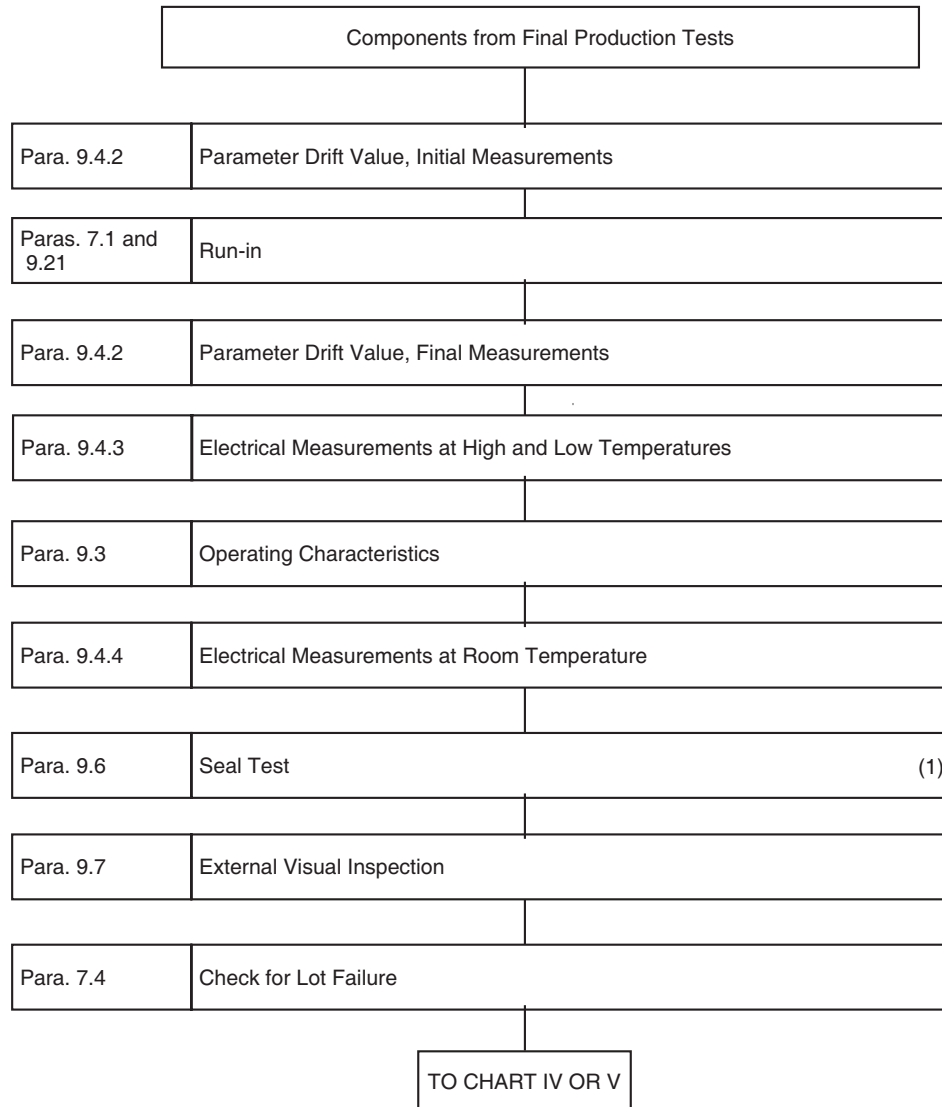

NOTES:

1. Seal Test rejects not to be counted for lot failure..

CHART IV - QUALIFICATION TESTS

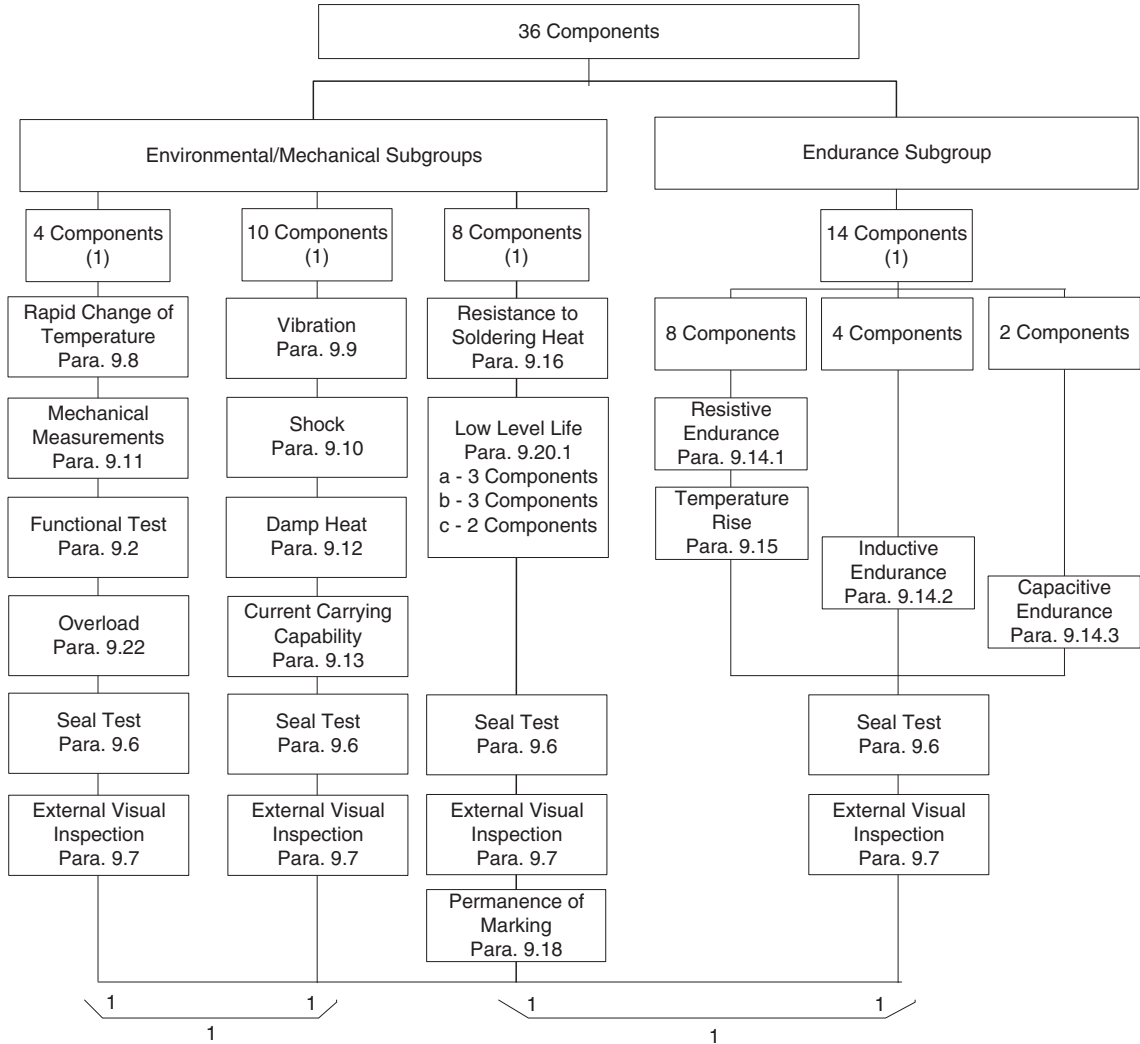

Total allowable number of failed components: 2.

NOTES:

1. For distribution within the subgroups, see Para. 8.1.2.

CHART V - LOT ACCEPTANCE TESTS

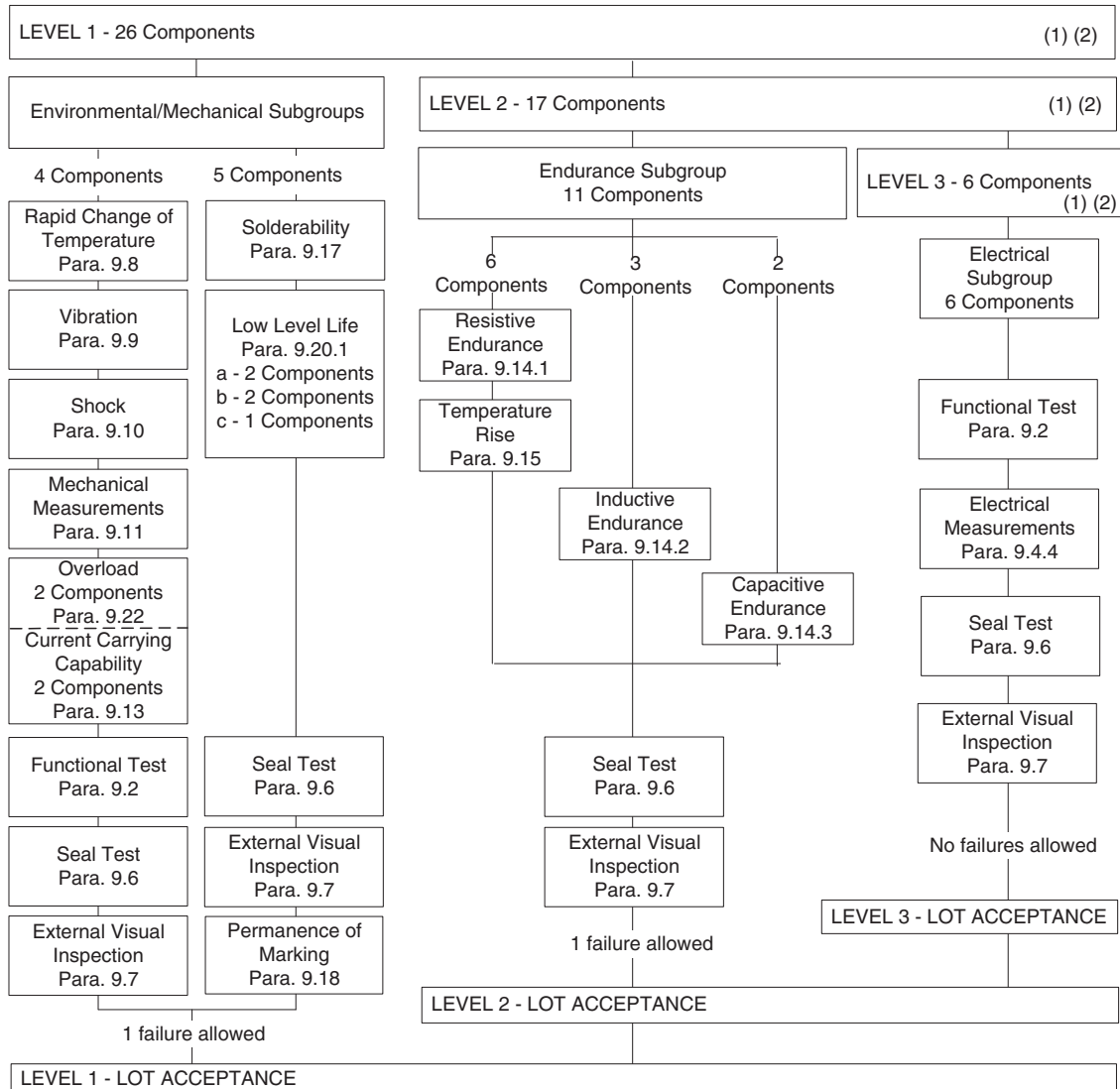

NOTES:

1. Including 6 deliverable items. See Para. 8.2.3(c).
2. For distribution within the subgroups, see Para. 8.2.2.

9. TEST METHODS AND PROCEDURES

If a Manufacturer elects to eliminate or modify a test method or procedure, the Manufacturer is still responsible for delivering components that meet all of the performance, quality and reliability requirements defined in this specification and the Detail Specification.

Documentation supporting the change shall be approved by the ESCC Executive and retained by the Manufacturer. It shall be copied, when requested, to the ESCC Executive.

The change shall be specified in the Detail Specification and in the PID.

9.1 INTERNAL VISUAL INSPECTION

In accordance with ESCC Basic Specification No. 20400.

9.2 FUNCTIONAL TEST

The circuit continuity shall be checked for each position and each pole, using a maximum current of 10mA.

Number of switching actions: 3.

9.3 OPERATING CHARACTERISTICS

- (a) Toggle Switches: Not applicable.
- (b) Sensitive Switches: See Para. 9.11.4.

9.4 ELECTRICAL MEASUREMENTS

9.4.1 General

The electrical measurements and methods shall be as follows.

9.4.1.1 *Contact Resistance*

The switches shall be tested in accordance with MIL-STD-202, Method 307. The following details shall apply:-

- (a) Method of Connection: For switches with wire lead terminals, this measurement shall be made 3mm maximum from the emergence of the lead from the switch.
- (b) Test conditions: 6V max./100mA max.
- (c) Points of measurement: All contacts in their closed position.
- (d) Number of activations prior to measurements: None.
- (e) Number of test activations: 3.
No load shall be applied to the contacts during contact transfer.
- (f) Number of measurements per activation: One in each closed contact position.

9.4.1.2 *Contact Bounce Times*

The values of for the dc test voltage and test current shall not exceed an open circuit voltage of 6V dc and a test current of 10mA.

The detection and display means (oscilloscope or equivalent) utilised in the circuit shall have a minimum bandwidth of 1MHz and a minimum time base accuracy of $\pm 5\%$.

The duration of the contact bounce shall be the maximum measurement occurring in 5 consecutive measurements of contact closure and of contact opening.

- For SPST switches (non-inverter type):
The test circuit shown in Figure 1A, or an equivalent, shall be used for detecting contact bounce. Contact bounce is the time duration measured from the moment of first closure (or opening) to the opening (or closure), i.e. the time duration between the moments when the voltage variations stay out of the range 10% to 90% of the test voltage (see Figure 1B).
- For SPDT switches (inverter type):

The test circuit shown in Figure 1C, or an equivalent, shall be used for detecting contact bounce and transfer times. The stabilised transfer duration includes the transfer duration of contacts and the bounce duration (see Figure 1D).

FIGURE 1A - TEST CIRCUIT FOR NON-INVERTER SWITCHES

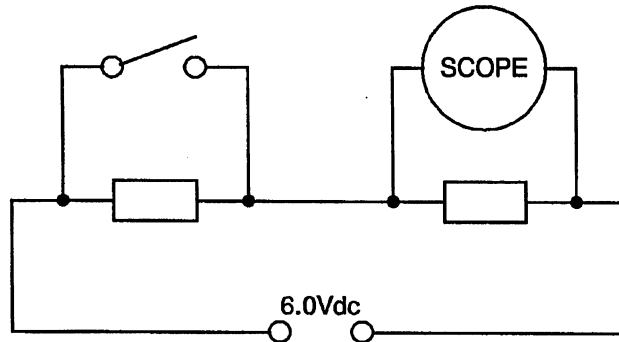

FIGURE 1B - TYPICAL OSCILLOSCOPE RECORDING FOR NON-INVERTER SWITCHES

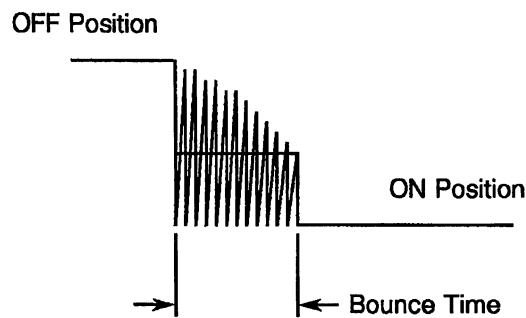

FIGURE 1C - TEST CIRCUIT FOR INVERTER SWITCHES

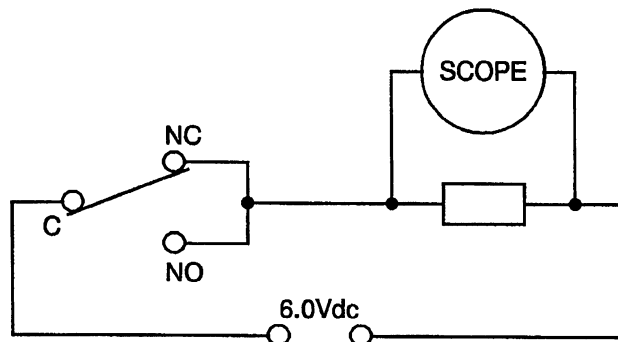
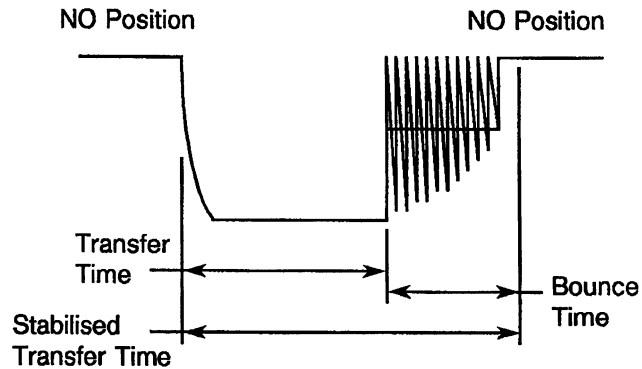

FIGURE 1D - TYPICAL OSCILLOSCOPE RECORDING FOR INVERTER SWITCHES



9.4.1.3 Voltage Proof

Components shall be tested in accordance with MIL-STD-202, Method 301. The following details shall apply:

- (a) Test Voltage:
As shown in the applicable ESCC Detail Specification.
- (b) Procedure for Multi-pole Switches:
The voltage shall be applied sequentially between:
 - The two terminations forming the circuit which has the smallest contact separation on opening. The switch actuator shall be in a position which causes these contacts to be open at the time of the test.
 - All terminations connected together and any exposed metal part not intended to be electrically connected.
- (c) Final Examination:
There shall be no visible or electrical sign of breakdown or flash-over during the test period and, after completion of the test, the samples shall be further visually examined for evidence of damage, arcing or breakdown.

9.4.1.4 Insulation Resistance

Devices shall be tested in accordance with MIL-STD-202, Method 302. The following details and exception shall apply:-

- (a) Test Voltage:
As specified in the applicable ESCC Detail Specification.
- (b) Points of Measurement:
The terminals being connected all together, the measurement is performed between terminals and the metallic part of case.

9.4.2 Parameter Drift Value Measurements

At each of the relevant data points for components of testing level B, measurements shall be made of all

parameters listed in Table 4 of the Detail Specification. All values obtained shall be recorded against serial numbers and the parameter drift calculated.

9.4.3 Electrical Measurements at High and Low Temperatures

For components of testing level B, the electrical measurements at high and low temperatures shall be made in accordance with Table 3 of the Detail Specification. Where sample testing is applied, note the requirements of Para. 8.2.3(b). For testing level B, all values obtained shall be recorded against serial numbers.

Unless otherwise defined in the Detail Specification, if more than 20 units have to be measured, the measurement shall be performed on a sample basis in accordance with IEC 60410, using Inspection Level II, Table II-A and AQL=1.0%.

9.4.4 Electrical Measurements at Room Temperature

For components of testing level B, the measurements of electrical characteristics shall be made in accordance with Table 2 of the Detail Specification. Where sample testing is applied, note the requirements of Para. 8.2.3(b). For testing level B, all values obtained shall be recorded against serial numbers.

9.4.5 Electrical Measurements during Endurance Testing

At each of the relevant data points specified for endurance testing, measurements shall be made of all parameters listed in Table 6 of the Detail Specification. All values obtained shall be recorded against serial numbers and the parameter drift calculated, if required.

9.5 DIMENSION CHECK

In accordance with ESCC Basic Specification No. 20500 and the Detail Specification. To be performed on 5 samples only.

If 1 failure occurs, the complete lot shall be checked.

9.6 SEAL TEST

9.6.1 Gross Leak

(a) For Waterproof Devices:

The samples shall be subjected to Test Qa of IEC Publication No. 60068-2-17. The samples shall be mounted on lid of pressurised test chamber and submerged in water. The air pressure shall be 1050mBar \pm 50 mBar for a period of 1 minute and the samples shall be submitted to 3 switching operations. There shall be no evidence of repetitive bubbling.

(b) For Hermetically Sealed Devices:

The samples shall be subjected to Test Qc of IEC Publication No. 60068-2-17, Method 2, using an inert fluorocarbon test liquid at $+125\pm 2^{\circ}\text{C}$. There shall be no evidence of repetitive bubbling.

9.6.2 Fine Leak (for Hermetically Sealed Devices)

The samples shall be subjected to Test Qk of IEC Publication No. 60068-2-17, Method 1, Severity 1000h. Unless otherwise stated in the Detail specification, immersion pressure shall not exceed 4Bars.

9.7 EXTERNAL VISUAL INSPECTION

In accordance with ESCC Basic Specification No. 20500.

9.8 RAPID CHANGE OF TEMPERATURE

The samples shall be subjected to Test Na of IEC Publication No. 60068-2-14 and for each cycle the duration of exposure at each extreme temperature shall be 30 minutes. The operating temperature extremes shall be as defined in Table 1(b) of the Detail specification. The number of cycles shall be 10.

The samples shall withstand the extremes of high and low temperature without visible damage.

9.9 VIBRATION

9.9.1 Mounting

The samples shall be mechanically connected to the test apparatus, either directly or by means of a fixture of the Detail Specification. Mounting fixtures shall be such as to enable the samples to be tested along 3 mutually perpendicular axes in turn, which should be chosen so that faults are most likely to be revealed.

External connections, necessary for measuring and supply purposes, should add the minimum restraint and mass.

9.9.2 Procedure

The samples shall be subjected to Test Fc of IEC Publication No. 60068-2-6.

Sweep Frequency: 10 to 2000Hz.

The entire frequency range of 10 to 2000Hz and return to 10Hz shall be traversed logarithmically in 20 minutes. This cycle shall be performed 6 times in each of the 3 directions (a total of 18 times), so that the motion shall be applied for a total period of approximately 6 hours.

From 10 to 58 Hz, the vibration amplitude shall be 4mm double amplitude. From 58 to 2000Hz, the vibration acceleration shall be 30g.

9.9.3 Electrical Conditions

All open and closed contacts shall be monitored. Closed contacts may be wired in series to monitor for opening of contacts, and open contacts may be wired in parallel to monitor for closing of contacts.

9.9.4 Failure

A component shall be considered as a failed component when the intermittent opening of closed contacts or intermittent closing of open contacts exceeds, once or more, the duration prescribed in the Detail Specification.

9.9.5 Final Inspection

The samples shall be visually examined and there shall be no evidence of mechanical damage.

9.10 SHOCK

9.10.1 Mounting

See Para. 9.9.1.

9.10.2 Procedure

the samples shall be subjected to Test Ea of IEC Publication No. 60068-2-27. Unless otherwise prescribed in the Detail specification, the following conditions shall be applicable:

- Shape of the shock pulse: half sine.
- Peak acceleration: 100g.
- Duration of the pulse: 6ms.
- Number of shocks: 18 (3 shocks in each of the 2 directions along the 3 mutually perpendicular axes of the test specimen).

9.10.3 Electrical Conditions

See Para. 9.9.3

9.10.4 Failure

See Para. 9.9.4.

9.10.5 Final Inspection and Measurements

The samples shall be subjected to the following tests:

- Voltage proof: See Para. 9.4.1.3.
- Contact resistance: See Para. 9.4.1.1.

The samples shall be visually examined and there shall be no evidence of mechanical damage.

9.11 MECHANICAL MEASUREMENTS

9.11.1 Robustness of Terminations

The samples shall be subjected to Test Ua1 of IEC Publication No. 60068-2-21. The load shall be 20N.

Test duration: 10s.

The samples shall be visually examined. There shall be no visible evidence of damage other than clamping tool marks on the terminations.

9.11.2 Strength of Mounting Bushing

Bushing-mounted switches shall be mounted on a metal panel using their normal mounting means and hardware. A torque in accordance with Table 6 of the Detail specification shall be applied to the mounting nut of switches.

A torque of 0.6Nm shall be applied to the mounted switch body.

Test duration: 1 minute.

9.11.3 Strength of Actuator

After the following tests, the switch shall operate mechanically and electrically as specified in the ESCC Detail Specification.

9.11.3.1 *Toggle Switches*

A force in accordance with Table 6 of the Detail Specification shall be applied to the actuating lever for 1 minute under each of the following conditions:

- (a) Perpendicular to the lever axis and parallel to the line of lever travel at each position of the lever. For lever-lock types, the test shall be conducted at each fixed position of the lever.

- (b) Perpendicular to the lever axis and perpendicular to the line of travel at each lever position.
- (c) Coaxial with the lever axis away from the lever point, throughout the entire range of lever travel.
- (d) Applied to the tip of the actuating lever, coaxial with the lever axis and toward the lever pivot, throughout the entire range of lever travel. For lever-lock types, this test is only applicable to those changes in lever position which may be accomplished without lifting the lever from its detent position.

After this test, the functional test (Para. 9.2) shall be performed.

9.11.3.2 *Sensitive Switches*

The force in accordance with Table 6 of the Detail specification shall be applied to the tip of the actuator for 1 minute under each of the following conditions:

- (a) Perpendicular to the actuator at each position.
- (b) Coaxial with the actuator axis away from the switch throughout the entire range of actuator movements.
- (c) Coaxial with the actuator axis toward the switch.

After this test, the functional test (Para. 9.2) shall be performed.

9.11.4 Travels and Forces (for Sensitive Switches)

The following characteristics shall be measured:

- (a) Actuation force.
- (b) Release force.
- (c) Pre-travel.
- (d) Over-travel
- (e) Differential travel.

The point of application of the force applied shall be in the direction of the axis of the actuator. The limits are as specified in the Detail Specification (Table 2(b)).

9.12 DAMP HEAT

Before starting this test, the components shall be subjected to 10 cycles of the test defined in Para. 9.8. No measurements shall be made before or after this cycling.

9.12.1 Procedure

The samples shall be subjected to Test Db of IEC Publication No. 60068-2-30 for 6 cycles of 24 hours at an upper temperature of +55°C. A DC voltage of 100V or V_N , whichever is less, shall be applied during the cycling between terminals and frame.

9.12.2 Final Inspection and Measurements

After not less than 4 or more than 24 hours, a voltage proof measurement shall be performed and the samples shall be visually examined for evidence of corrosion or obliteration of markings.

9.13 CURRENT CARRYING CAPABILITY

9.13.1 Procedure

The samples shall be placed in a test chamber according to the following requirements:

- (a) Overload in temperature: +20°C higher than the high operating temperature defined in Table 1(b) of the Detail Specification.
- (b) After the temperature stabilisation of the samples, an overload DC current of twice the maximum rated current shall be applied during 10 minutes on a resistive load without switching operation.

9.13.2 Final Inspection and Measurements

After cooling down to room temperature, the functional test (Para 9.2) and the contact resistance shall be performed. There shall be no welding, sticking or damage of contacts.

9.14 OPERATING LIFE

The switches shall be distributed according to the applicable Chart. One contact of each pole shall be connected to an independent test circuit meeting the specified conditions.

| | Load | Pressure | Supply |
|---|------------|--------------|--------|
| 1 | Resistive | Room Ambient | AC |
| 2 | Resistive | Room Ambient | DC |
| 3 | Inductive | 50mBar (1) | DC |
| 4 | Capacitive | 50mBar (1) | DC |

NOTES:

- 1. For non-hermetic devices only. For hermetic devices, use room ambient pressure.

9.14.1 Resistive Endurance Test

- (a) Duration: 10000 cycles.
- (b) Operating Conditions
The components shall be distributed between DC and AC voltage in ambient room conditions. The mounting shall be consistent with Para. 9.15.1. A rate of cycling up to 60 cycles per minute may be used. During this test, duty cycle shall be about 50% ON.

The test current shall be at maximum rated current and the voltage at the rated voltage, as specified in Table 1(b) of the Detail Specification.

- (c) Electrical Measurements
At intermediate data points and end-points, the measurements shall be in accordance with Table 6 of the Detail Specification.
- (d) Data Points
The intermediate and end-points are defined by the number of cycles: 0, 5000, 10000.

9.14.2 Inductive Endurance Test

- (a) Duration: 10000 cycles.
- (b) Operating conditions
The components shall be subjected to DC voltage in ambient temperature and low pressure (50mBar where applicable). The circuit used for this test shall have a time constant between 2ms and 3ms. A rate of cycling up to 60 cycles per minute may be used. During this test, duty cycle shall be about 50% ON.

The test current shall be at maximum rated current and the voltage at the rated voltage, as specified

in Table 1(b) of the Detail Specification.

(c) Electrical Measurements

At intermediate data points and end-points, the measurements shall be in accordance with Table 6 of the Detail Specification.

(d) Data Points

The intermediate and end-points are defined by the number of cycles: 0, 5000, 10000.

9.14.3 Capacitive Endurance Test

(a) Duration: 10000 cycles.

(b) Operating Conditions

The components shall be subjected to DC rated voltage in ambient temperature and low pressure (50mBar where applicable).

The electrical circuit shall be as follows:

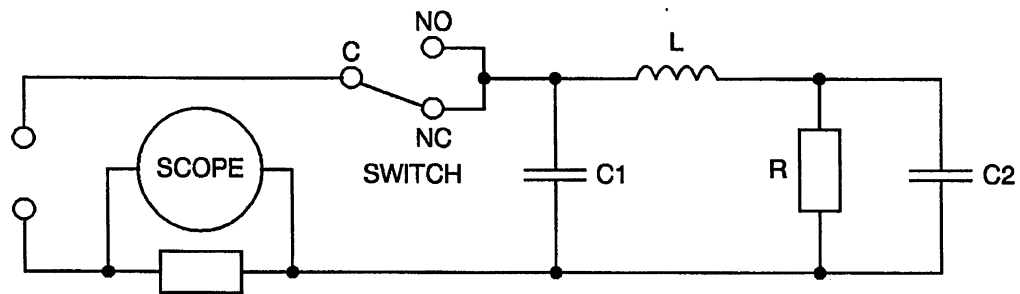

The electrical parameters are defined in the following diagram.

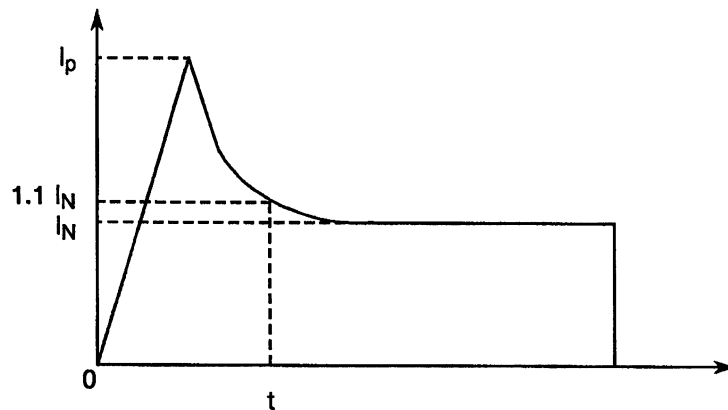

A rate of 4 cycles per minute shall be used. During this test, duty cycle shall be about 50% ON. The parameters I_p and t shall be as specified in Table 5(b) of the Detail Specification.

(c) Electrical Measurements

At intermediate data points and end-points, the measurements shall be in accordance with Table 6 of the Detail Specification.

(d) Data Points

The intermediate and end-points are defined by the number of cycles: 0, 5000, 10000.

9.15 TEMPERATURE RISE

This test shall be performed on the samples previously subjected to the Resistive Endurance Test energised with the DC current. The temperature rise of the terminals of the samples shall be determined

by the following procedure.

9.15.1 Mounting

The samples shall be suspended by their terminals during the test. They shall be separated from each other by a distance of not less than 25mm. During the test, radiant shields may be placed between units, so that overheating of one unit will not affect a nearby unit. Lead wires shall be of copper, 150mm long, and of the size specified hereunder:

| Rated current (A) | Wire Size | |
|-------------------|-----------|---------------|
| | AWG | Diameter (mm) |
| Up to 3 | 24 | 0.64 |
| 3+ to 5 | 22 | 0.85 |
| 5+ to 11 | 20 | 1.04 |
| 11+ to 16 | 18 | 1.29 |
| 16+ to 22 | 16 | 1.53 |
| 22+ to 32 | 14 | 1.87 |

9.15.2 Ambient Test Temperature

The test shall be conducted at room temperature without forced-air ventilation or any means of component cooling.

9.15.3 Electrical Conditions

Each contact submitted to test 9.14.1 shall be energised without switching operation to the rated DC current defined in Table 1(b) of the Detail Specification.

9.15.4 Measurements

At the end of a 1 hour period, and while the sample is still energised, the terminal temperature rise shall be determined by the use of thermocouple at a point adjacent to the insulating medium.

the temperature rise (ΔT) shall be calculated by the following formula:

$$\Delta T = T - t$$

Where T= temperature in °C of the thermocouple, t=ambient temperature in °C.

9.15.5 Limit

Unless otherwise specified in the Detail specification, the temperature rise shall not exceed 30°C.

9.16 RESISTANCE TO SOLDERING HEAT

9.16.1 Procedure

Before starting this test, the samples shall be stabilised at room temperature for not less than 15 minutes. Each terminal, to which solder is normally applied, shall be subjected to the requirements of IEC Publication No. 60068-2-20, Test Tb Method 2 - soldering iron size B at +350°C, with the following conditions:-

Distance: 2(+0.5-0) mm from the switch header.

Duration: 10(+1-1)s.

No heat sink or thermal screen shall be used during this test. For multipole switches, 3 terminals per device shall be tested.

9.16.2 Final Inspection and Measurements

After a recovery period, under room conditions, of 1 to 2 hours, the samples shall be visually examined and there shall be no evidence of physical damage. Voltage proof and contact resistance shall be performed and shall comply with Table 6 of the Detail Specification.

9.17 SOLDERABILITY

9.17.1 Procedure

Two samples shall be subjected to Test Ta of IEC Publication No. 60068-2-20, using Method 1. The terminations shall be immersed up to 2(+0.5-0)mm from the point where they emerge from the body.

9.17.2 Final Examination

The samples shall be examined in accordance with the requirements of IEC Publication No. 60068-2-20, Test Ta, using Para. 4.6.4 of that document.

9.18 PERMANENCE OF MARKING

In accordance with ESCC Basic Specification No. 24800.

9.19 FINAL ASSEMBLY

Final assembly shall be performed in accordance with the Process Identification Document (PID).

9.20 LOW LEVEL LIFE

9.20.1 Low Level Life during Qualification Testing

- (a) Duration: 100000 cycles.
- (b) Operating Conditions
the switches shall be distributed and submitted to electrical conditions according to the applicable Chart.

| Test | Electrical Test Conditions | |
|------|----------------------------|-------|
| a | 30mV | 10mA |
| b | 3V | 100µA |
| c | 28V | 35mA |

The following details shall apply:

- Environment: Ambient Room conditions.
- Cycling rate: 10 to 18 cycles per minute. At the Manufacturer's option, a faster rate of cycling up to 60 cycles/minute may be used.
- The DC power source shall be applied to each pair of contacts.
- The monitoring shall provide, as a minimum, the number of operating cycles applied and the number of opening/closing detected on each pair of contacts.

- (c) Electrical Measurements
Measurements at intermediate data points and end-points shall be in accordance with Table 6 of the Detail Specification.
- (d) Data Points
The intermediate and end-points are defined by the numbers of cycles:
0, 10000, 30000, 50000, 70000, 100000

9.20.2 Low Level Life during Lot Acceptance Testing

- (a) Duration: 40000 cycles.
- (b) Operating Conditions
The switches shall be distributed and submitted to electrical conditions according to the applicable Chart.

| Test | Electrical Test Conditions | |
|------|----------------------------|-------|
| a | 30mV | 10mA |
| b | 3V | 100µA |
| c | 28V | 35mA |

The following details shall apply:

- Environment: Ambient Room conditions.
- Cycling rate: 10 to 18 cycles per minute. At the Manufacturer's option, a faster rate of cycling up to 60 cycles/minute may be used.
- The DC power source shall be applied to each pair of contacts.
- The monitoring shall provide, as a minimum, the number of operating cycles applied and the number of opening/closing detected on each pair of contacts.

- (c) Electrical Measurements
Measurements at intermediate data points and end-points shall be in accordance with Table 6 of the Detail Specification.
- (d) Data Points
The intermediate and end-points are defined by the numbers of cycles:
0, 10000, 20000, 30000, 40000.

9.21 RUN-IN

The test shall be conducted in accordance with the following requirements:

- (a) Duration: 500 cycles.
- (b) Operating Conditions
The following details shall apply:
 - Environment: Ambient Room conditions.
 - Cycling rate: 10 to 18 cycles per minute. At the Manufacturer's option, a faster rate of cycling up to 60 cycles/minute may be used.
 - The DC power source shall be applied to each pair of contacts. The voltage shall not exceed 6V and the current through the contacts shall not exceed 10mA on a resistive load.
 - The monitoring shall provide, as a minimum, the number of operating cycles applied and the number of opening/closing detected on each pair of contacts.
- (c) Failures

A sample shall be considered as failed when one or more misses occur.

9.22 OVERLOAD

9.22.1 Procedure

The switches shall make and brake 150% of the rated DC current (Table 1 of the Detail specification) on a resistive load, at the applicable voltage and electrical frequency, for 50 cycles of operation at room condition.

9.22.2 Final Inspection

After test, the contact resistance shall be performed.

10. DATA DOCUMENTATION

10.1 GENERAL

For the qualification approval records and with each component delivery, a data documentation package is required. Depending on the testing level and lot acceptance level specified for the component, this package shall be compiled from:-

- (a) Cover sheet (or sheets).
- (b) List of equipment (testing and measuring).
- (c) List of test references.
- (d) Special in-process control test data (when required by the Detail Specification).
- (e) Final production test data (Chart II) (but see Para. 10.6).
- (f) Screening and electrical measurement data (Chart III).
- (g) Qualification test data (Chart IV).
- (h) Lot acceptance test data (Chart V) (when applicable).
- (i) Failed component list (see Paras. 7.3 and 8.4) and failure analysis report (see Para. 8.4).
- (j) Certificate of Conformity.
- (k) Radiographic inspection photographs (if performed).

Items (a) to (k) inclusive shall be grouped, preferably as subpackages and, for identification purposes, each page shall include the following information:

- ESCC Component Number
- Manufacturer's name.
- Lot identification.
- Date of establishment of the document.
- Page number.

10.1.1 Qualification Approval

In the case of qualification approval, the items listed in Para. 10.1 (a) to (k) less item (h) are required.

10.1.2 Testing Level B

10.1.2.1 Qualified Components

For deliveries of qualified components, the following documentation shall be supplied:-

- (a) Cover sheet (if all of the information is not included on the Certificate of Conformity).
- (b) Certificate of Conformity (including range of delivered serial numbers).
- (c) Attributes record of measurements, tests and inspections performed in Chart II, Chart III (including PDA figure) and Chart V (where applicable).
- (d) Failed components list.

10.1.2.2 *Unqualified Components*

For deliveries of unqualified components, the documentation to be supplied shall be in accordance with Para. 10.1.2.1 plus the following:-

- (a) Read and record data from Chart III
- (b) Special in-process control data (where applicable).
- (c) Failure analysis report on failed components.

10.1.3 Testing Level C

Not applicable.

10.1.4 Data Retention/Data Access

If not delivered, all data shall be retained by the Manufacturer for a minimum of 5 years during which time it shall be available to the ESCC Executive and the Orderer, if requested, for review. The Manufacturer shall deliver variables Data/Reports to the Orderer if required by the Purchase Order.

10.2 COVER SHEET(S)

The cover sheet (or sheets) of the data documentation package shall include as a minimum:-

- (a) Reference to the Detail Specification, including issue and date.
- (b) Reference to the applicable ESCC Generic Specification, including issue and date.
- (c) Component type and number.
- (d) Lot identification.
- (e) Range of delivered serial numbers (for components of testing level B).
- (f) Number of Purchase Order.
- (g) Information relative to any additions to this specification and/or the Detail Specification.
- (h) Manufacturer's name and address.
- (i) Location of the manufacturing plant.
- (j) Signature on behalf of Manufacturer.
- (k) Total number of pages of the data package.

10.3 LIST OF EQUIPMENT USED

A list of equipment used for tests and measurements shall be prepared, if not in accordance with the data given in the Process Identification Document (PID). Where applicable, this list shall contain inventory number, Manufacturer's type number, serial number, etc. This list shall indicate for which tests such equipment was used.

10.4 LIST OF TEST REFERENCES

This list shall include all Manufacturer's references or codes which are necessary to correlate the test data provided with the applicable tests specified in the tables of the Detail Specification.

10.5 SPECIAL IN-PROCESS CONTROL DATA

As specified in the Detail Specification.

10.6 FINAL PRODUCTION TEST DATA (CHART II)

A test result summary shall be compiled showing the total number of components submitted to, and the total number rejected after, each of the following tests:'

- Internal visual inspection (Para. 9.1)
- Functional test (Para. 9.2)
- Operating characteristic (Para. 9.3)
- Electrical measurements at room temperature (Para. 9.4.4)
- Dimension check (Para. 9.5)
- Seal test (if performed) (Para. 9.6)
- External visual inspection (Para. 9.7)

The final production test data shall form an integral part of the data documentation package, but it is not a mandatory requirement that it be delivered with the qualification lot or delivery lot. However, the data package to be delivered shall contain the information as detailed in Paras. 10.1.2 and 10.1.3 or at least shall contain a list of final production tests actually performed and a certification that the data is available for review.

10.7 SCREENING AND ELECTRICAL MEASUREMENT DATA (CHART III)

10.7.1 Testing Level B

For components of testing level B, all data shall refer to the relevant serial numbers. Against these serial numbers, data shall be recorded of the following:-

- (a) Number of misses using run-in.
- (b) Values obtained during measurements at high and low temperatures (Table 3 of the Detail Specification).
- (c) Values obtained during measurements at room temperature (Table 2 of the Detail Specification).
- (d) Failures during external visual inspection.
- (e) Failures during the Seal Test (if performed).
- (f) Photographs from radiographic inspection, including those of reject components (if requested in the PID).

10.7.2 Testing Level C

Not applicable.

10.8 QUALIFICATION TEST DATA (CHART IV)

All data shall be referenced to the relevant serial numbers. Detailed records shall be provided of the components submitted to each test in each of the subgroups and of those rejected.

Detailed data shall be provided of all electrical measurements made in accordance with Tables 2 and 6 of the Detail Specification, as and where applicable.

10.9 LOT ACCEPTANCE TEST DATA (CHART V)

10.9.1 Testing Level B

All data shall be referenced to the relevant serial numbers. Detailed records shall be provided of the components submitted to each test in each of the subgroups (as relevant to the lot acceptance level) and of those rejected.

Detailed data shall be provided of all electrical measurements made in accordance with Table 6 of the Detail Specification, as and where applicable.

10.9.2 Testing Level C

Not applicable.

10.10 FAILED COMPONENT LIST AND FAILURE ANALYSIS REPORT

The failed component list and failure analysis report shall provide full details of:-

- (a) The reference number and description of the test or measurement performed as defined in this specification and/or the Detail Specification.
- (b) The serial number (if applicable) of the failed component.
- (c) The failed parameter and the failure mode of the component.
- (d) Detailed failure analysis, if requested.

10.11 CERTIFICATE OF CONFORMITY

A Certificate of Conformity shall be established as defined in ESCC Basic Specification No. 20100.

11. DELIVERY

For qualification approval, the disposition of the qualification test lot and its related documentation shall be as specified in ESCC Basic Specification No. 20100 and the relevant paragraphs of Section 10 of this specification.

For procurement, for each order, the items forming the delivery are:-

- (a) The delivery lot.
- (b) The components used for lot acceptance testing, (when applicable), but not forming part of the delivery lot (see Para's 8.2.3(d), 8.2.4(b) and 8.2.5(b)).
- (c) The relevant documentation in accordance with the requirements of Section 10 of this specification.

In the case of a component for which a valid qualification approval is in force, all data of all components submitted to LA1 and LA2 testing shall also be copied, when requested, to the ESCC Executive.

12. PACKAGING AND DESPATCH

The packaging and despatch of components to this specification shall be in accordance with the requirements of ESCC Basic Specification No. 20600.

APPENDIX A

LTPD SAMPLING PLAN LOT SIZES GREATER THAN 200 DEVICES

Minimum size of sample to be tested to assure with a 90% confidence that a lot whose percent defective equals the specified LTPD is not accepted (single sample).

| Max. Percent Defective (LTPD) or λ | 50 | 30 | 20 | 15 | 10 | 7 | 5 | 3 | 2 | 1.5 | 1 | 0.7 | 0.5 | 0.3 | 0.2 | 0.15 | 0.1 |
|--|---|---------------|---------------|---------------|---------------|---------------|---------------|----------------|----------------|-----------------|-----------------|-----------------|-----------------|------------------|------------------|------------------|------------------|
| Acceptance Number (c) (r=c+1) | MINIMUM SAMPLE SIZES (FOR DEVICE-HOURS REQUIRED FOR LIFE TEST, MULTIPLY BY 1000) | | | | | | | | | | | | | | | | |
| 0 | 5 (1.03) | 8 (0.64) | 11 (0.46) | 15 (0.34) | 22 (0.23) | 32 (0.16) | 45 (0.11) | 76 (0.07) | 116 (0.04) | 153 (0.03) | 231 (0.02) | 328 (0.02) | 461 (0.01) | 767 (0.007) | 1152 (0.005) | 1534 (0.003) | 2303 (0.002) |
| 1 | 8 (4.4) | 13 (2.7) | 18 (2.0) | 25 (1.4) | 38 (0.94) | 55 (0.65) | 77 (0.46) | 129 (0.28) | 195 (0.18) | 258 (0.14) | 390 (0.09) | 555 (0.06) | 778 (0.045) | 1296 (0.027) | 1946 (0.018) | 2592 (0.013) | 3891 (0.009) |
| 2 | 11 (7.4) | 18 (4.5) | 25 (3.4) | 34 (2.24) | 52 (1.6) | 75 (1.1) | 105 (0.78) | 176 (0.47) | 266 (0.31) | 354 (0.23) | 533 (0.15) | 759 (0.11) | 1065 (0.080) | 1773 (0.045) | 2662 (0.031) | 3547 (0.022) | 5323 (0.015) |
| 3 | 13 (10.5) | 22 (6.2) | 32 (4.4) | 43 (3.2) | 65 (2.1) | 94 (1.5) | 132 (1.0) | 221 (0.62) | 333 (0.41) | 444 (0.31) | 668 (0.20) | 953 (0.14) | 1337 (0.10) | 2226 (0.062) | 3341 (0.041) | 4452 (0.031) | 6681 (0.018) |
| 4 | 16 (12.3) | 27 (7.3) | 38 (5.3) | 52 (3.9) | 78 (2.6) | 113 (1.8) | 158 (1.3) | 265 (0.75) | 398 (0.50) | 531 (0.37) | 798 (0.25) | 1140 (0.17) | 1599 (0.12) | 2663 (0.074) | 3997 (0.049) | 5327 (0.037) | 7994 (0.025) |
| 5 | 19 (13.8) | 31 (8.4) | 45 (6.0) | 60 (4.4) | 91 (2.9) | 131 (2.0) | 184 (1.4) | 308 (0.85) | 462 (0.57) | 617 (0.42) | 927 (0.28) | 1323 (0.20) | 1855 (0.14) | 3090 (0.085) | 4638 (0.056) | 6181 (0.042) | 9275 (0.028) |
| 6 | 21 (15.6) | 35 (9.4) | 51 (6.6) | 68 (4.9) | 104 (3.2) | 149 (2.2) | 209 (1.6) | 349 (0.94) | 528 (0.62) | 700 (0.47) | 1054 (0.31) | 1503 (0.22) | 2107 (0.155) | 3509 (0.093) | 5267 (0.062) | 7019 (0.047) | 10533 (0.031) |
| 7 | 24 (16.6) | 39 (10.2) | 57 (7.2) | 77 (5.3) | 116 (3.5) | 166 (2.4) | 234 (1.7) | 390 (1.0) | 589 (0.67) | 783 (0.51) | 1178 (0.34) | 1680 (0.24) | 2355 (0.17) | 3922 (0.101) | 5886 (0.067) | 7845 (0.051) | 11771 (0.034) |
| 8 | 26 (18.1) | 43 (10.9) | 63 (7.7) | 85 (5.6) | 128 (3.7) | 184 (2.6) | 258 (1.8) | 431 (1.1) | 648 (0.72) | 864 (0.54) | 1300 (0.36) | 1854 (0.25) | 2599 (0.18) | 4329 (0.108) | 6498 (0.072) | 8660 (0.054) | 12995 (0.036) |
| 9 | 28 (19.4) | 47 (11.5) | 69 (8.1) | 93 (6.0) | 140 (3.9) | 201 (2.7) | 282 (1.9) | 471 (1.2) | 709 (0.77) | 945 (0.58) | 1421 (0.38) | 2027 (0.27) | 2842 (0.19) | 4733 (0.114) | 7103 (0.077) | 9468 (0.057) | 14206 (0.038) |
| 10 | 31 (19.9) | 51 (12.1) | 75 (8.4) | 100 (6.3) | 152 (4.1) | 218 (2.9) | 306 (2.0) | 511 (1.2) | 770 (0.80) | 1025 (0.60) | 1541 (0.40) | 2199 (0.28) | 3082 (0.20) | 5133 (0.120) | 7704 (0.080) | 10268 (0.060) | 15407 (0.040) |
| 11 | 33 (21.0) | 54 (12.8) | 83 (8.3) | 111 (6.2) | 166 (4.2) | 238 (2.9) | 332 (2.1) | 555 (1.2) | 832 (0.83) | 1109 (0.62) | 1664 (0.42) | 2378 (0.29) | 3323 (0.21) | 5546 (0.12) | 8319 (0.083) | 11092 (0.062) | 16638 (0.042) |
| 12 | 36 (21.4) | 59 (13.0) | 89 (8.6) | 119 (6.5) | 178 (4.3) | 254 (3.0) | 356 (2.2) | 594 (1.3) | 890 (0.86) | 1187 (0.65) | 1781 (0.43) | 2544 (0.3) | 3562 (0.22) | 5936 (0.13) | 8904 (0.086) | 11872 (0.065) | 17808 (0.043) |
| 13 | 38 (22.3) | 63 (13.4) | 95 (8.9) | 126 (6.7) | 190 (4.5) | 271 (3.1) | 379 (2.26) | 632 (1.3) | 948 (0.89) | 1264 (0.67) | 1896 (0.44) | 2709 (0.31) | 3793 (0.22) | 6321 (0.134) | 9482 (0.089) | 12643 (0.067) | 18964 (0.045) |
| 14 | 40 (23.1) | 67 (13.8) | 101 (9.2) | 134 (6.9) | 201 (4.6) | 288 (3.2) | 403 (2.3) | 672 (1.4) | 1007 (0.92) | 1343 (0.69) | 2015 (0.46) | 2878 (0.32) | 4029 (0.23) | 6716 (0.138) | 10073 (0.092) | 13431 (0.069) | 20146 (0.046) |
| 15 | 43 (23.3) | 71 (14.1) | 107 (9.4) | 142 (7.1) | 213 (4.7) | 305 (3.3) | 426 (2.36) | 711 (1.41) | 1066 (0.94) | 1422 (0.71) | 2133 (0.47) | 3046 (0.33) | 4265 (0.235) | 7108 (0.141) | 10662 (0.094) | 14216 (0.070) | 21324 (0.047) |
| 16 | 45 (24.1) | 74 (14.0) | 112 (9.7) | 150 (7.2) | 225 (4.8) | 321 (3.37) | 450 (2.41) | 750 (1.44) | 1124 (0.96) | 1499 (0.72) | 2249 (0.48) | 3212 (0.337) | 4497 (0.241) | 7496 (0.144) | 11244 (0.096) | 14992 (0.072) | 22487 (0.048) |
| 17 | 47 (24.7) | 79 (14.7) | 118 (9.86) | 158 (7.36) | 236 (4.93) | 338 (3.44) | 473 (2.46) | 788 (1.48) | 1182 (0.98) | 1576 (0.74) | 2364 (0.49) | 3377 (0.344) | 4728 (0.246) | 7880 (0.148) | 11819 (0.098) | 15759 (0.074) | 23639 (0.049) |
| 18 | 50 (24.9) | 83 (15.0) | 124 (10.0) | 165 (7.54) | 248 (5.02) | 354 (3.51) | 496 (2.51) | 826 (1.51) | 1239 (1.0) | 1652 (0.75) | 2478 (0.50) | 3540 (0.351) | 4956 (0.251) | 8260 (0.151) | 12390 (0.100) | 16520 (0.075) | 24780 (0.050) |
| 19 | 52 (25.5) | 86 (15.4) | 130 (10.2) | 173 (7.76) | 259 (5.12) | 370 (3.58) | 518 (2.56) | 864 (1.53) | 1296 (1.02) | 1728 (0.77) | 2591 (0.52) | 3702 (0.358) | 5183 (0.256) | 8638 (0.153) | 12957 (0.102) | 17276 (0.077) | 25914 (0.051) |
| 20 | 54 (26.1) | 90 (15.6) | 135 (10.4) | 180 (7.82) | 271 (5.19) | 386 (3.65) | 541 (2.60) | 902 (1.56) | 1353 (1.04) | 1803 (0.78) | 2705 (0.52) | 3864 (0.364) | 5410 (0.260) | 9017 (0.156) | 13526 (0.104) | 18034 (0.078) | 27051 (0.052) |
| 26 | 65 (27.0) | 109 (16.1) | 163 (10.8) | 217 (8.08) | 326 (5.38) | 466 (3.76) | 652 (2.69) | 1086 (1.61) | 1629 (1.08) | 2173 (0.807) | 3259 (0.538) | 4656 (0.376) | 6518 (0.269) | 10863 (0.161) | 16295 (0.108) | 21726 (0.081) | 32589 (0.054) |

1. Sample sizes are based upon the Poisson exponential binomial limit.
2. The minimum quality (approximate AQL) required to accept (on the average) 19 of 20 lots is shown in parentheses for information only.

LTPD SAMPLING PLAN LOT SIZES LESS THAN, OR EQUAL TO, 200 DEVICES

| C=0 | | | | | | | | | | | | |
|-----|----------|----------|----------|----------|----------|----------|----------|----------|----------|----------|----------|----------|
| N | 10 | 20 | 30 | 40 | 50 | 60 | 80 | 100 | 120 | 150 | 160 | 200 |
| n | AQL LTPD | AQL LTPD | AQL LTPD | AQL LTPD | AQL LTPD | AQL LTPD | AQL LTPD | AQL LTPD | AQL LTPD | AQL LTPD | AQL LTPD | AQL LTPD |
| 2 | 2.2 65 | 2.5 66 | 2.5 67 | 2.5 67 | 2.5 67 | 2.5 68 | 2.5 68 | 2.5 68 | 2.5 68 | 2.5 68 | 2.5 68 | 2.5 68 |
| 4 | 1.2 36 | 1.2 40 | 1.2 42 | 1.2 42 | 1.3 42 | 1.3 43 | 1.3 43 | 1.3 43 | 1.3 43 | 1.3 43 | 1.3 44 | 1.3 44 |
| 5 | 1.0 29 | 1.0 33 | 1.0 34 | 1.0 35 | 1.0 35 | 1.0 35 | 1.0 36 | 1.0 36 | 1.0 37 | 1.0 37 | 1.0 37 | 1.0 37 |
| 8 | 0.5 15 | 0.6 20 | 0.6 22 | 0.6 23 | 0.6 23 | 0.6 23 | 0.6 24 | 0.7 24 | 0.7 24 | 0.7 24 | 0.7 24 | 0.7 25 |
| 10 | | 0.4 15 | 0.5 17 | 0.5 19 | 0.5 19 | 0.5 19 | 0.5 20 | 0.5 20 | 0.5 20 | 0.5 20 | 0.5 20 | 0.5 20 |
| 16 | | 0.2 6.9 | 0.25 10 | 0.25 11 | 0.3 11 | 0.3 12 | 0.3 12 | 0.3 13 | 0.3 13 | 0.3 13 | 0.3 13 | 0.3 13 |
| 20 | | | 0.2 6.8 | 0.2 8.0 | 0.25 8.7 | 0.25 9.0 | 0.25 9.4 | 0.25 10 | 0.25 10 | 0.25 10 | 0.25 10 | 0.25 11 |
| 25 | | | 0.15 4.3 | 0.15 5.7 | 0.2 6.4 | 0.2 6.9 | 0.2 7.4 | 0.2 7.5 | 0.2 7.6 | 0.2 7.7 | 0.2 7.8 | 0.2 7.9 |
| 32 | | | | 0.1 3.7 | 0.1 4.4 | 0.1 5.0 | 0.1 5.5 | 0.1 5.9 | 0.15 6.0 | 0.15 6.2 | 0.15 6.3 | 0.15 6.3 |
| 40 | | | | | 0.1 3.0 | 0.1 3.4 | 0.1 4.0 | 0.1 4.5 | 0.1 4.6 | 0.1 4.9 | 0.1 5.0 | 0.15 5.0 |
| 50 | | | | | | 0.1 2.3 | 0.1 2.9 | 0.10 3.3 | 0.10 3.5 | 0.10 3.7 | 0.10 3.7 | 0.10 3.9 |
| 64 | | | | | | | 0.08 1.7 | 0.08 2.2 | 0.08 2.5 | 0.08 2.7 | 0.08 2.8 | 0.08 2.9 |
| 80 | | | | | | | | 0.07 1.5 | 0.07 1.7 | 0.07 2.0 | 0.07 2.1 | 0.07 2.2 |
| 100 | | | | | | | | | 0.05 1.1 | 0.05 1.5 | 0.05 1.5 | 0.05 1.7 |
| 125 | | | | | | | | | 0.04 0.8 | 0.04 0.8 | 0.04 0.9 | 0.04 1.2 |
| 128 | | | | | | | | | | 0.04 0.8 | 0.04 0.9 | 0.04 1.1 |
| 160 | | | | | | | | | | | | 0.03 0.7 |
| C=1 | | | | | | | | | | | | |
| N | 10 | 20 | 30 | 40 | 50 | 60 | 80 | 100 | 120 | 150 | 160 | 200 |
| n | AQL LTPD | AQL LTPD | AQL LTPD | AQL LTPD | AQL LTPD | AQL LTPD | AQL LTPD | AQL LTPD | AQL LTPD | AQL LTPD | AQL LTPD | AQL LTPD |
| 2 | 27 95 | 24 95 | 24 95 | 23 95 | 23 95 | 23 95 | 23 95 | 23 95 | 23 95 | 22 95 | 22 95 | 22 95 |
| 4 | 15 62 | 12 66 | 12 66 | 11 67 | 11 67 | 10 67 | 10 67 | 10 67 | 10 67 | 9.8 67 | 9.7 67 | 9.7 68 |
| 5 | 13 51 | 10 55 | 8.8 56 | 8.5 57 | 8.4 57 | 8.1 58 | 7.9 58 | 7.6 58 | 7.5 58 | 7.5 58 | 7.5 58 | 7.5 58 |
| 8 | 11 28 | 7.2 35 | 6.2 38 | 5.8 38 | 5.4 39 | 5.0 39 | 4.7 39 | 4.5 39 | 4.3 39 | 4.3 40 | 4.2 40 | 4.2 40 |
| 10 | | 6.2 30 | 5.0 30 | 4.6 31 | 4.2 32 | 4.2 32 | 4.2 32 | 3.9 33 | 3.5 33 | 3.3 33 | 3.3 33 | 3.3 33 |
| 16 | | 5.6 15 | 4.2 18 | 3.8 18 | 3.4 20 | 3.0 20 | 2.9 21 | 2.6 21 | 2.5 21 | 2.3 21 | 2.3 22 | 2.2 22 |
| 20 | | | 4.0 13 | 3.2 15 | 2.8 16 | 2.5 16 | 2.4 16 | 2.3 16 | 2.1 17 | 2.0 17 | 2.0 17 | 2.0 18 |
| 25 | | | 3.8 9.2 | 3.1 11 | 2.5 12 | 2.2 13 | 2.0 13 | 1.8 13 | 1.7 13 | 1.6 14 | 1.6 14 | 1.6 14 |
| 32 | | | | 3.1 7.4 | 2.4 8.2 | 2.1 9.0 | 1.8 9.9 | 1.6 10 | 1.5 10.5 | 1.4 11 | 1.3 11 | 1.3 11 |
| 40 | | | | | 2.4 5.9 | 2.1 6.8 | 1.6 7.6 | 1.4 7.8 | 1.3 8.2 | 1.2 8.3 | 1.2 8.4 | 1.2 8.6 |
| 50 | | | | | | 1.7 4.6 | 1.4 5.6 | 1.2 6.1 | 1.2 6.4 | 1.0 6.5 | 0.9 6.7 | 0.9 6.7 |
| 64 | | | | | | | 1.3 3.8 | 1.1 4.4 | 1.0 4.7 | 0.8 5.0 | 0.8 5.0 | 0.7 5.2 |
| 80 | | | | | | | | 1.1 3.0 | 1.0 3.4 | 0.8 3.7 | 0.7 3.8 | 0.6 4.0 |
| 100 | | | | | | | | | 0.9 2.5 | 0.7 2.8 | 0.7 2.8 | 0.6 3.0 |
| 125 | | | | | | | | | | 0.7 1.9 | 0.7 2.0 | 0.5 2.2 |
| 128 | | | | | | | | | | 0.7 1.7 | 0.7 1.9 | 0.5 2.2 |
| 160 | | | | | | | | | | | | 0.5 1.5 |
| C=2 | | | | | | | | | | | | |
| N | 10 | 20 | 30 | 40 | 50 | 60 | 80 | 100 | 120 | 150 | 160 | 200 |
| n | AQL LTPD | AQL LTPD | AQL LTPD | AQL LTPD | AQL LTPD | AQL LTPD | AQL LTPD | AQL LTPD | AQL LTPD | AQL LTPD | AQL LTPD | AQL LTPD |
| 4 | 33 82 | 28 83 | 27 84 | 27 85 | 27 85 | 26 85 | 26 85 | 26 86 | 26 86 | 25 86 | 25 86 | 25 86 |
| 5 | 27 69 | 23 73 | 21 74 | 20 74 | 20 74 | 20 75 | 20 75 | 19 75 | 19 75 | 19 75 | 19 75 | 19 75 |
| 8 | 22 42 | 15 49 | 14 49 | 13 52 | 13 52 | 13 52 | 12 53 | 12 53 | 12 53 | 11 53 | 11 53 | 11 53 |
| 10 | | 13 39 | 11 42 | 11 42 | 10 43 | 10 43 | 9.6 43 | 9.2 44 | 9.1 44 | 8.9 44 | 8.9 44 | 8.7 44 |
| 16 | | 11 22 | 8.6 25 | 6.9 27 | 6.8 27 | 6.4 27 | 6.0 28 | 6.0 29 | 5.9 29 | 5.9 29 | 5.7 29 | 5.5 30 |
| 20 | | | 7.7 19 | 6.2 21 | 5.9 22 | 5.6 22 | 5.1 23 | 4.8 23 | 4.8 23 | 4.6 23 | 4.5 24 | 4.5 24 |
| 25 | | | 7.4 13 | 6.0 16 | 4.9 17 | 4.5 17 | 4.3 18 | 4.1 18 | 3.9 18 | 3.7 18 | 3.7 19 | 3.7 19 |
| 32 | | | | 5.5 11 | 4.8 12 | 4.3 13 | 3.6 14 | 3.4 14 | 3.2 14 | 3.0 14.5 | 3.0 15 | 2.9 15 |
| 40 | | | | | 4.6 8.9 | 3.9 9.8 | 3.1 11 | 2.8 12 | 2.6 12 | 2.4 12 | 2.4 12 | 2.3 12 |
| 50 | | | | | | 3.5 6.9 | 2.8 8.1 | 2.4 8.4 | 2.3 8.6 | 2.1 9.0 | 2.1 9.3 | 2.0 9.5 |
| 64 | | | | | | | 2.6 5.7 | 2.2 6.2 | 2.0 6.6 | 1.8 7.1 | 1.7 7.1 | 1.6 7.4 |
| 80 | | | | | | | | 2.1 4.5 | 1.8 4.9 | 1.6 5.4 | 1.5 5.4 | 1.4 5.6 |
| 100 | | | | | | | | | 1.8 3.5 | 1.4 3.9 | 1.4 4.0 | 1.2 4.4 |
| 125 | | | | | | | | | | 1.4 2.8 | 1.3 2.9 | 1.1 3.3 |
| 128 | | | | | | | | | | 1.4 2.6 | 1.3 2.9 | 1.1 3.2 |
| 160 | | | | | | | | | | | | 1.1 2.3 |

This table gives the AQL and LTPD values associated with certain single sampling plans (Acceptance Number 'C', Sample Size 'n' and Lot Size 'N'). the table has the following features:-

- (a) Calculations are based upon the hyper-geometric distribution (exact theory) for lot sizes of 200 devices or less.
- (b) The AQL of a sampling plan is defined as the interpolated Percent Defective for which there is a 0.95 probability of acceptance under the plan. The AQL so defined need not be a realisable Lot Percent Defective for the lot size involved (e.g., 12% is not a realisable Percent Defective for a lot size of 20 devices).
- (c) The LTPD of a sampling plan is defined as the interpolated Percent Defective for which there is a 0.10 probability of lot acceptance under the plan. The LTPD so defined need not be a realisable Lot Percent Defective for the lot size involved.
- (d) The sequence of sample sizes and lot sizes are generated by taking products of preceding numbers

in the respective sequences and the numbers 2 and 5.