



**CONNECTORS, MINIATURE, ELECTRICAL,
CIRCULAR, BAYONET COUPLING, CRIMP-TYPE,
REMOVABLE CONTACTS,
BASED ON TYPE DFE
ESCC Detail Specification No. 3401/007**

**ISSUE 1
October 2002**



	ESCC Detail Specification		PAGE ii ISSUE 1
---	---------------------------	--	--------------------

LEGAL DISCLAIMER AND COPYRIGHT

European Space Agency, Copyright © 2002. All rights reserved.

The European Space Agency disclaims any liability or responsibility, to any person or entity, with respect to any loss or damage caused, or alleged to be caused, directly or indirectly by the use and application of this ESCC publication.

This publication, without the prior permission of the European Space Agency and provided that it is not used for a commercial purpose, may be:

- copied in whole in any medium without alteration or modification.
- copied in part, in any medium, provided that the ESCC document identification, comprising the ESCC symbol, document number and document issue, is removed.



europaean space agency
agence spatiale européenne

Pages 1/19

CONNECTORS, MINIATURE, ELECTRICAL, CIRCULAR,
BAYONET COUPLING, CRIMP-TYPE, REMOVABLE CONTACTS
BASED ON TYPE DFE

ESA/SCC Detail Specification No. 3401/007

Issue 1

February 1979

Revision 'A'

June 1984



space components
coordination group

Approved by SCCG

Date: 12-2-79

..... *J. K. Williams*

J. K. Williams
(Chairman)

Approved by ESA

Date: 12-2-79

..... *[Signature]*

(Director General or his
Deputy)



ESA/SCC Detail Specification
No. 3401/007

Rev. 'A'

PAGE 2

ISSUE 1

DOCUMENTATION CHANGE NOTICE

Rev. Letter	Rev. Date	Reference	CHANGE Item	Approved DCR No.
'A'	Jun. '84		This Issue incorporates all modifications agreed on the basis of Policy DCR No. 21016 for adaptation to new qualification requirements. Cover Page DCN Figure 2 : Some 'G' max. dimensions amended	None None 23116
			This document has been transferred from hardcopy to electronic format. The content is unchanged but minor differences in presentation exist.	



TABLE OF CONTENTS

	<u>Page</u>
1. <u>GENERAL</u>	5
1.1 Scope	5
1.2 Range of Components	5
1.3 Maximum Ratings	5
1.4 Parameter Derating Information	5
1.5 Physical Dimensions	5
1.6 Functional Diagram	5
2. <u>APPLICABLE DOCUMENTS</u>	5
3. <u>TERMS, DEFINITIONS, ABBREVIATIONS, SYMBOLS AND UNITS</u>	6
4. <u>REQUIREMENTS</u>	6
4.1 General	6
4.2 Deviations from Generic Specification	6
4.2.1 Deviations from Final Production Tests	6
4.2.2 Deviations from Environmental and Endurance Tests	6
4.3 Mechanical Requirements	6
4.3.1 Dimension Check	6
4.3.2 Weight	6
4.3.3 Connector Engagement and Separation Forces	14
4.3.4 Insert Retention	14
4.3.5 Endurance	14
4.4 Materials and Finishes	14
4.4.1 Shells	14
4.4.2 Inserts	14
4.5 Marking	14
4.5.1 General	14
4.5.2 The SCC Component Number	14
4.5.3 Characteristics	15
4.5.4 Traceability Information	17
4.5.5 Marking of Small Components	17
4.6 Electrical Measurements	17
4.6.1 Electrical Measurements at Room Temperature	17
4.6.2 Electrical Measurements at High and Low Temperatures	17
4.6.3 Circuits for Electrical Measurements	17
4.7 Screening Tests	17
4.8 Environmental and Endurance Tests	18
4.8.1 Electrical Measurements on Completion of Environmental Tests	18
4.8.2 Electrical Measurements at Intermediate Points during Endurance Tests	18
4.8.3 Electrical Measurements on Completion of Endurance Tests	18



	<u>Page</u>
4.8.4 Conditions for Operating Life Tests	18
4.8.5 Electrical Circuits for Operating Life Tests	18
4.8.6 Conditions for High Temperature Storage Test	18

TABLES

1(a) Range of Components	7
1(b) Maximum Ratings	7
2 Electrical Measurements at Room Temperature	19
3 Not Applicable	
4 Not Applicable	
5 Not Applicable	
6 Electrical Measurements after Environmental and Endurance Tests	19

FIGURES

1 Voltage Proof versus Altitude	8
2 Physical Dimensions	9

APPENDICES (Applicable to specific Manufacturers only)

None.

**1. GENERAL****1.1 SCOPE**

This specification details the ratings, physical and electrical characteristics, test and inspection data for Connectors, Miniature, Electrical, Circular, Bayonet Coupling, Crimp-Type, Removable Contacts, based on Type DFE.

It shall be read in conjunction with:

- ESA/SCC Generic Specification No. 3401, Connectors, Electrical, Rectangular and Circular, and
- ESA/SCC Detail Specification No. 3401/009, Contacts, Electrical, Crimp-Type for 3401/007 and 3401/008 Connectors,

the requirements of which are supplemented herein.

1.2 RANGE OF COMPONENTS

The different sizes of the basic type of connectors specified herein, which are also covered by this specification, together with their mechanical characteristics, are given in Table 1(a).

1.3 MAXIMUM RATINGS

The maximum ratings, which shall not be exceeded at any time during use or storage, applicable to the connectors specified herein, are scheduled in Table 1(b).

1.4 PARAMETER DERATING INFORMATION

The applicable derating information for the connectors specified herein is shown in Figure 1.

1.5 PHYSICAL DIMENSIONS

The physical dimensions of the connectors specified herein, are shown in Figure 2.

1.6 FUNCTIONAL DIAGRAM

Not applicable.

2. APPLICABLE DOCUMENTS

The following documents form part of this specification and shall be read in conjunction with it:-

- (a) ESA/SCC Generic Specification No. 3401, Connectors, Electrical, Circular and Rectangular.



- (b) ESA/SCC Detail Specification No. 3401/009, Contacts, Electrical, for 3401/007 and 3401/008 Connectors.
- (c) MIL-STD-202, Test Methods for Electronic and Electrical Component Parts.
- (d) MIL-STD-1344, Test Methods for Electrical Connectors.

3. TERMS, DEFINITIONS, ABBREVIATIONS, SYMBOLS AND UNITS

For the purpose of this specification, the terms, definitions, abbreviations, symbols and units specified in ESA/SCC Basic Specification No. 21300 shall apply.

4. REQUIREMENTS

4.1 GENERAL

The complete requirements for procurement of the connectors specified herein shall be as stated in this specification and ESA/SCC Generic Specification No. 3401. Deviations from the Generic Specification, applicable to this specification only, are listed in Para. 4.2.

Deviations from the applicable Generic Specification and this Detail Specification, formally agreed with specific Manufacturers on the basis that the alternative requirements are equivalent to the ESA/SCC requirements and do not affect the components' reliability, are listed in the appendices attached to this specification.

4.2 DEVIATIONS FROM GENERIC SPECIFICATION

4.2.1 Deviations from Final Production Tests

- (a) Para. 9.7, Magnetism Level: Not applicable.

4.2.2 Deviations from Environmental and Endurance Tests

- (a) Para. 9.8, Vibration: 20G, 10 - 2000 Hz.
- (b) Para. 9.9, Mechanical Shock: 100G, 11ms, half-sine wave.
- (c) Para. 9.13, Thermal Shock: Temperature as specified in Table 1(b).
- (d) Para. 9.15, Endurance: The number of cycles for plug with grounding fingers (shell type 57) shall be 250 only.
- (e) Para. 9.19, High Temperature Test: Temperature as specified in Table 1(b).

4.3 MECHANICAL REQUIREMENTS

4.3.1 Dimension Check

The dimensions of the connectors specified herein shall be checked. They shall conform to those shown in Figure 2.

4.3.2 Weight

The maximum weight of the connectors specified herein, without contacts, shall be as specified in Table 1(a).

**TABLE 1(a) - RANGE OF COMPONENTS**

SHELL STYLE	SHELL SIZE	WEIGHT (g) Max.	ENGAGEMENT & SEPARATION (Max. torque (cm/kg))
Receptacle	08	11	-
Receptacle	10	15	-
Receptacle	12	21.3	-
Receptacle	14	25	-
Receptacle	16	32.6	-
Receptacle	18	34.8	-
Receptacle	20	44.1	-
Receptacle	22	51.2	-
Receptacle	24	61.4	-
Plug	08	14.1	8
Plug	10	17.2	10
Plug	12	24.7	14
Plug	14	31	17
Plug	16	37.3	23
Plug	18	42	26
Plug	20	49	31
Plug	22	56	38
Plug	24	57	38

TABLE 1(b) - MAXIMUM RATINGS

No.	CHARACTERISTICS	SYMBOL	MAXIMUM RATINGS	UNIT	REMARKS
1	High Temperature	T _{amb}	+ 200	°C	
2	Low Temperature	T _{amb}	- 65	°C	
3	Voltage Proof	V _P	1500	V _{rms}	



FIGURE 1 - VOLTAGE PROOF VERSUS ALTITUDE

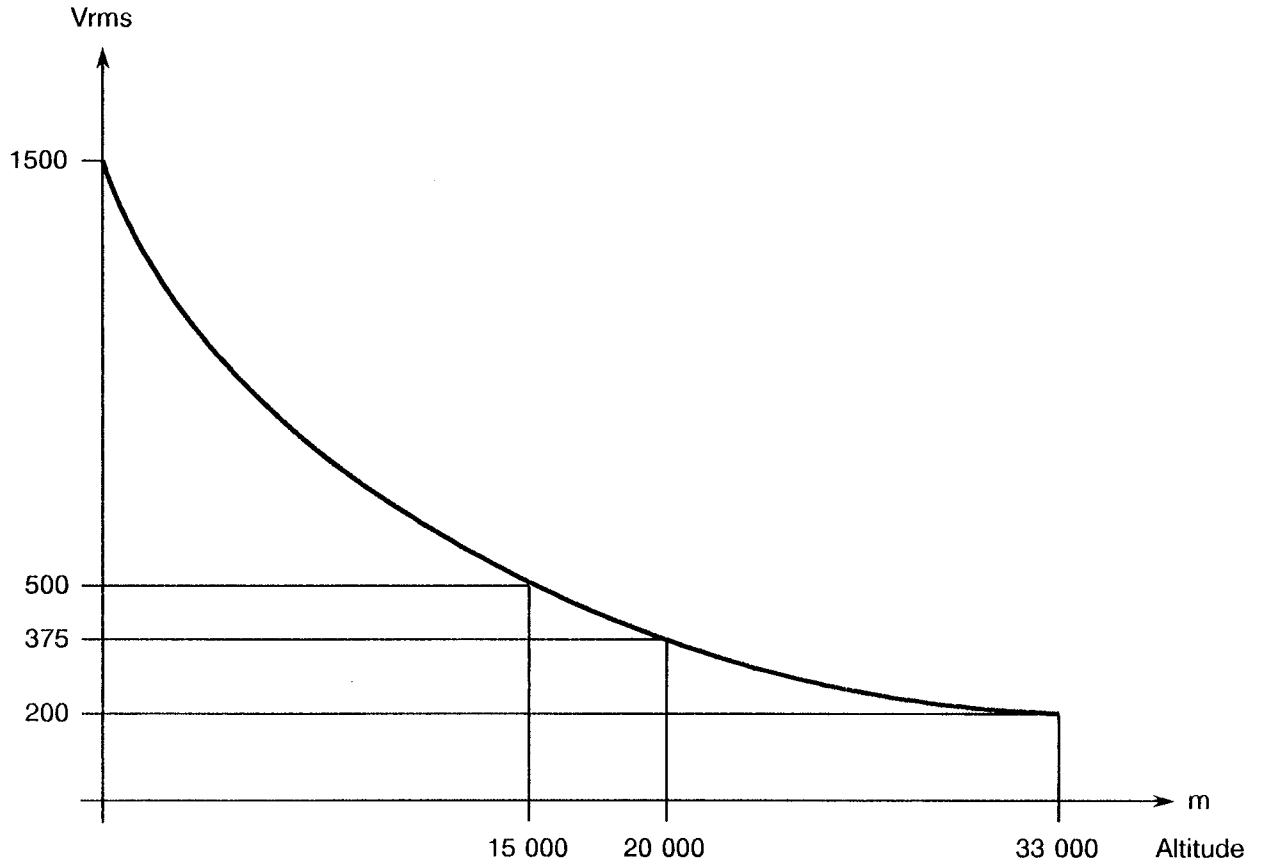
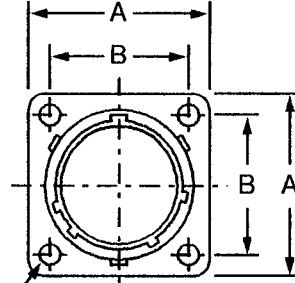
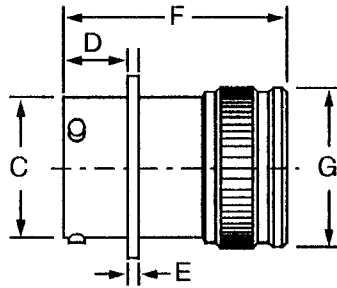



FIGURE 2 - PHYSICAL DIMENSIONS

SQUARE FLANGE
RECEPTACLE



4 holes $\varnothing 3.15 \pm 0.15$ for Shell Size 08 to 22
4 holes $\varnothing 3.73 \pm 0.15$ for Shell Size 24

Shell Size	Dimensions (mm)						
	A max.	B ± 0.1	C max.	D ± 0.15	E max.	F max.	G max.
08	21.10	15.08	12.03	11.13	2.00	36.60	15.67
10	24.35	18.26	15.01	11.13	2.00	36.60	18.70
12	26.70	20.62	19.07	11.13	2.00	36.60	21.80
14	29.05	23.02	22.24	11.13	2.00	36.60	25.00
16	31.30	24.58	25.42	11.13	2.00	36.60	28.20
18	33.70	26.98	28.60	11.13	2.00	36.60	30.94
20	36.85	29.36	31.77	14.30	2.55	38.15	34.16
22	39.95	31.76	34.94	14.30	2.55	38.15	37.29
24	43.15	34.92	38.12	15.10	2.55	38.15	40.50

PLUG

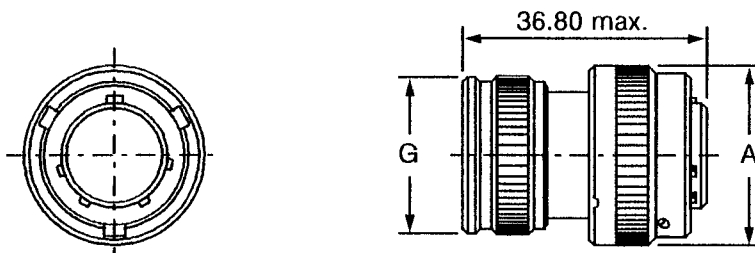

Shell Size	Dimensions (mm)	
	A max.	G max.
08	19.75	15.67
10	22.70	18.70
12	26.50	21.80
14	29.95	25.00
16	32.95	28.20
18	35.35	30.94
20	38.85	34.16
22	42.10	37.29
24	45.05	40.50



FIGURE 2 - PHYSICAL DIMENSIONS (CONTINUED)

SINGLE HOLE
MOUNTING
RECEPTACLE

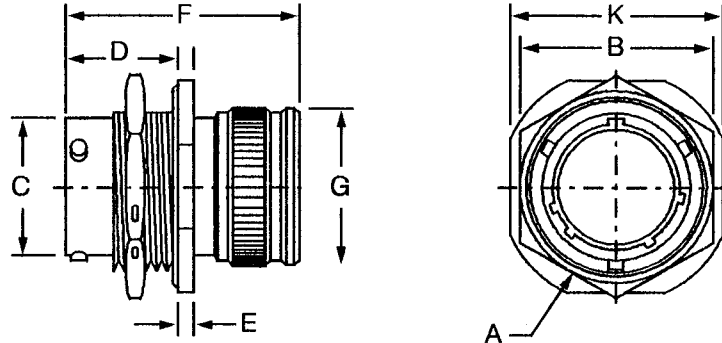

Shell Size	Dimensions (mm)							
	A max.	B max.	C max.	D ± 0.15	E max.	F max.	G max.	K max.
08	27.40	19.20	12.03	17.78	2.90	36.60	15.67	24.25
10	30.55	22.37	15.01	17.78	2.90	36.60	18.70	27.40
12	35.35	27.12	19.07	17.78	2.90	36.60	21.80	32.15
14	38.50	30.30	22.24	17.78	2.90	36.60	25.00	35.35
16	41.70	33.47	25.42	17.78	2.90	36.60	28.20	38.50
18	44.85	36.67	28.60	17.78	2.90	36.60	30.94	41.70
20	49.65	39.82	31.77	19.43	3.70	38.15	34.16	46.45
22	52.80	43.02	34.94	19.43	3.70	38.15	37.29	49.60
24	55.95	46.17	38.12	19.43	3.70	38.15	40.50	53.00

PLUG WITH
GROUNDING

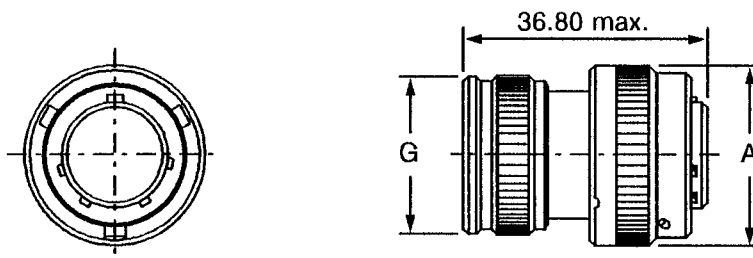

Shell Size	Dimensions (mm)	
	A max.	G max.
08	19.75	15.67
10	22.70	18.70
12	26.50	21.80
14	29.95	25.00
16	32.95	28.20
18	35.35	30.94
20	38.85	34.16
22	42.10	37.29
24	45.05	40.50



FIGURE 2 - PHYSICAL DIMENSIONS (CONTINUED)

FIGURE 2(a) - STANDARD CONTACT ARRANGEMENTS - FRONT VIEW PIN INSERT
(See Para. 4.5 for definition of numbers)

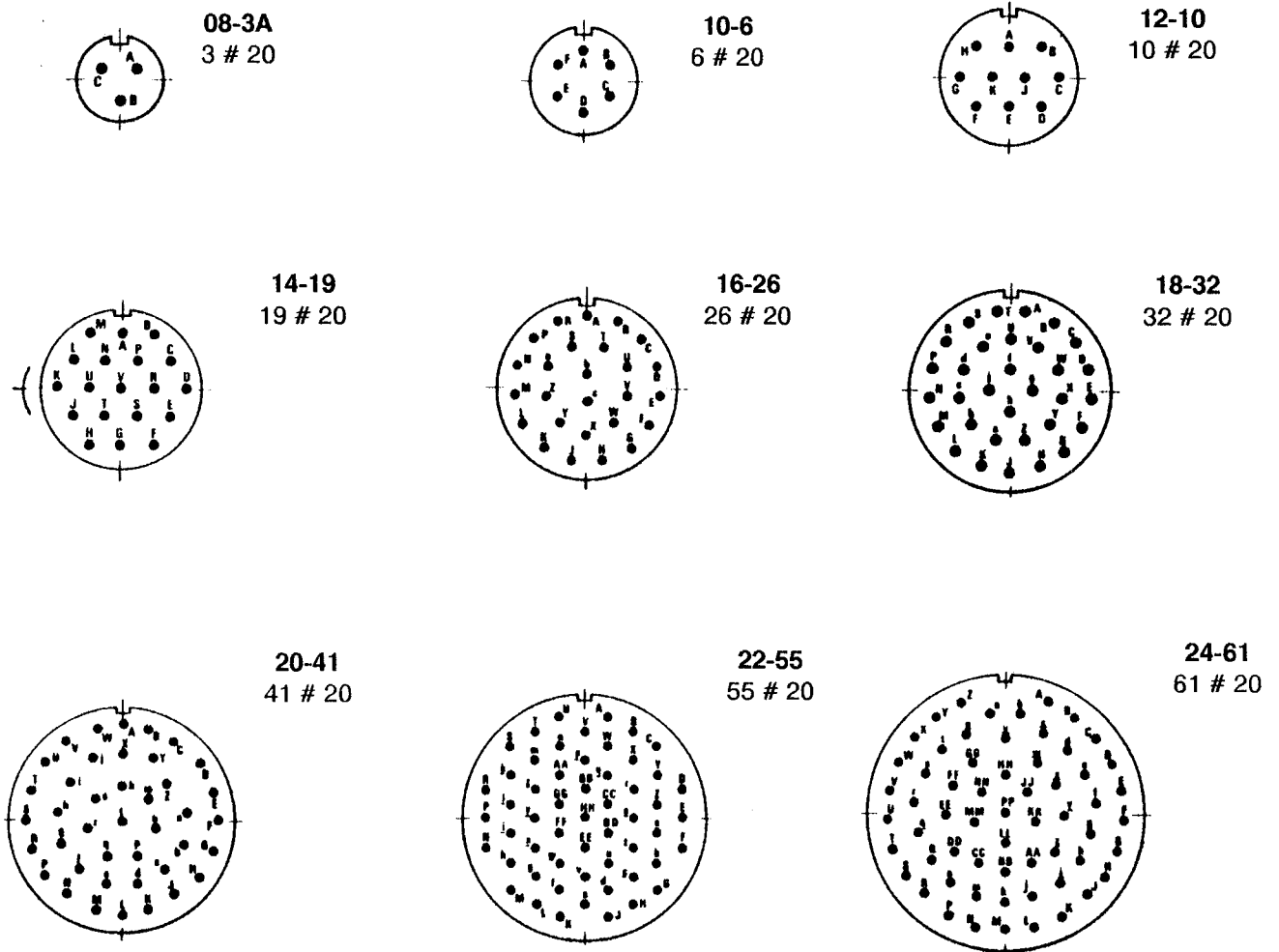

NOTES

1. Contact locations in conformity with the applicable MIL-STD drawing.



FIGURE 2 - PHYSICAL DIMENSIONS (CONTINUED)

FIGURE 2(b) - STANDARD CONTACT ARRANGEMENTS - FRONT VIEW PIN INSERT
(See Para. 4.5 for definition of numbers)

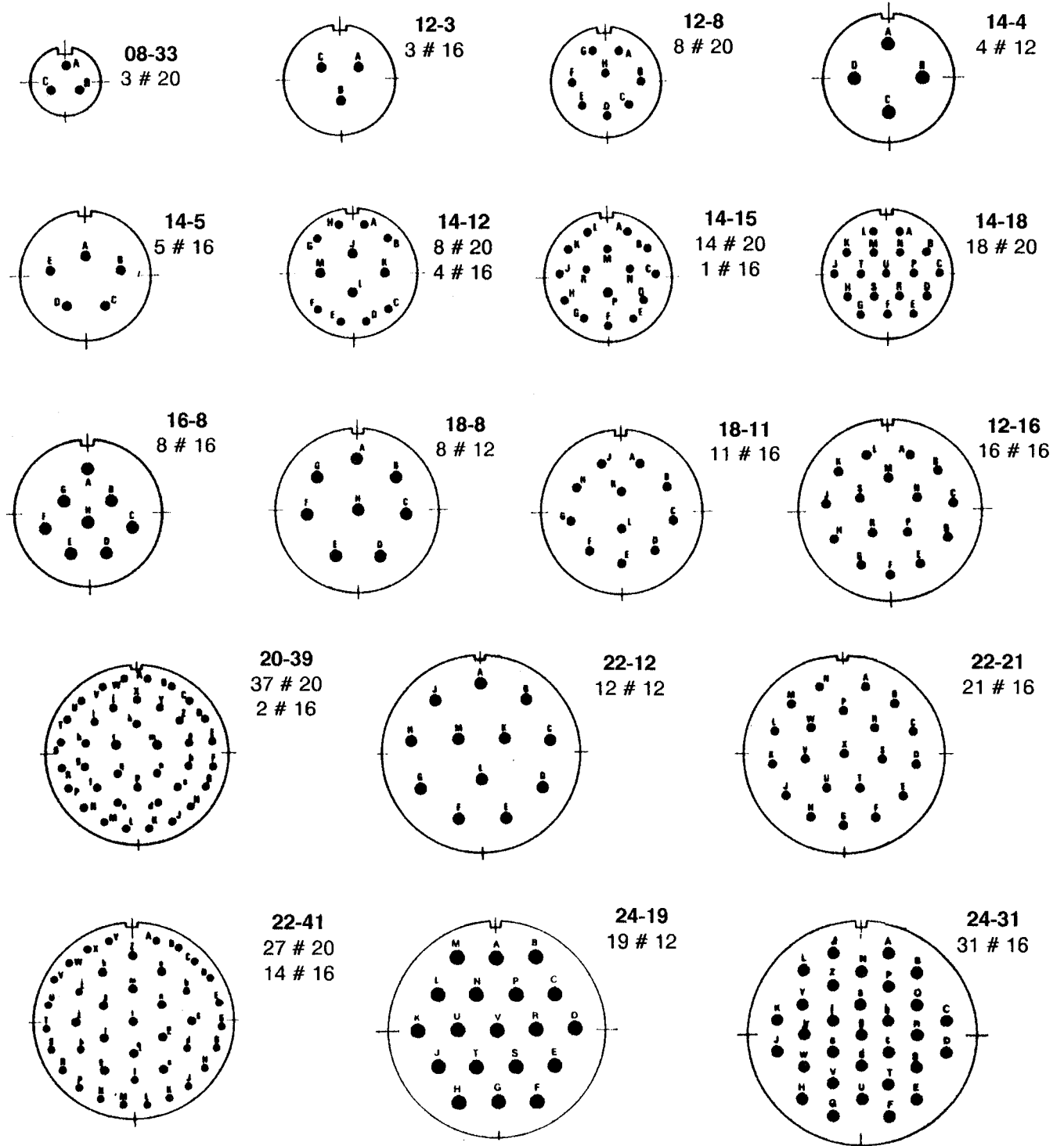
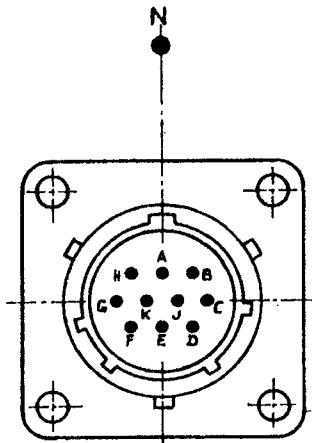

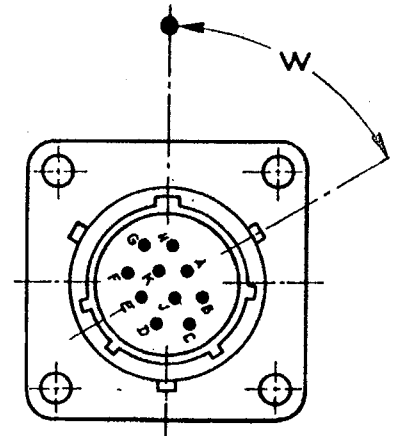

FIGURE 2 - PHYSICAL DIMENSIONS (CONTINUED)

FIGURE 2(c) - INSERT CLOCKING POSITIONS



Normal Position



Clocking Position W

The normal position is achieved when the vertical axis of the insert (Figures 2(a) and 2(b)) is the same as the axis of the key in the shell (position N). Mating of two connectors with the same contact arrangement, standing side by side, can be made fool-proof by rotating one of the inserts within its shell. Rotation shall be clockwise for male inserts and anti-clockwise for female inserts. Determined rotations give clocking position W, X, Y and Z as specified below:-

Clocking Positions (°)			
W	X	Y	Z
60	210		
90			
90			
		180	
90	112	203	292
60	155	270	295
40	92	184	273
43	90		
17	110	155	234
15	90	180	270
30	165	315	
54	152	180	331
60	105	275	338
62	119	241	340
85	138	222	265
238	318	333	347
63	144	252	333
45	126	225	
16	135	175	349
39			
30	142	226	314
30	165	315	
90	225		
90	180	270	324



4.3.3 Connector Engagement and Separation Forces

The torque applied for the engagement and separation of a plug and a receptacle shall conform to the values specified in Table 1(a).

4.3.4 Insert Retention

Connector inserts shall withstand a pressure of 5.27kg/cm² without being dislodged from the shell.

4.3.5 Endurance

The engagement and separation cycle rate shall not exceed 200 ± 100 cycles per hour.

4.4 MATERIALS AND FINISHES

The materials and finishes shall be as specified herein. Where a definite material is not specified, a material which will enable the connectors specified herein to meet the performance requirements of this specification shall be used. Acceptance or approval of any constituent material does not guarantee acceptance of the finished product.

4.4.1 Shells

Aluminium, nickel-plated. Where residual magnetism is of importance, a black anodise treatment can be ordered.

4.4.2 Inserts

Bonded sandwich: Silicone/Phenolic/Silicone.

4.5 MARKING

4.5.1 General

The marking of all components delivered to this specification shall be in accordance with the requirements of ESA/SCC Basic Specification No. 21700 and the following paragraphs. Each component shall be marked in respect of:-

- (a) The SCC Component Number.
- (b) Characteristics.
- (c) Traceability Information.

4.5.2 The SCC Component Number

The SCC Component Number shall be constituted and marked as follows:-

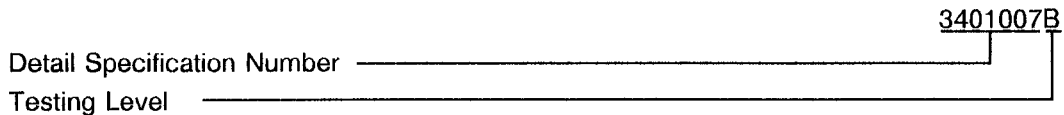



4.5.3 Characteristics

The characteristics to be marked in the following order of precedence are:-

- (a) Connector series.
- (b) Shell type.
- (c) Grounding.
- (d) Shell size.
- (e) Contact arrangement.
- (f) Type of contact.
- (g) Insert clocking position.
- (h) Contact dash number.
- (i) Modification.

The information shall be constituted and marked as follows:-

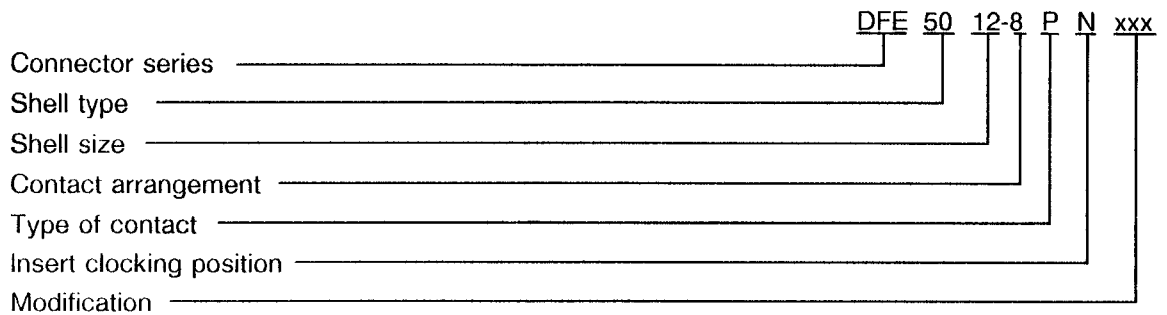

4.5.3.1 Connector Series

This connector series shall be designated by the letters DFE.

4.5.3.2 Shell Type

The shell types shall be designated by the following numbers:-

Code No.	Shell Type
50	Square flange receptacle
54	Single hole mounting receptacle
56	Plug
57	Plug with grounding



4.5.3.3 Shell Sizes and Contact Arrangements

Shell sizes and contact arrangements are closely related to each other and shall be indicated by the following codes:-

CODE		Number of Contacts
Shell Size	Contact Arrangement	
08	3A	Numbers of contacts and contact sizes are as shown in Figures 2(a) and 2(b)
08	33	
10	6	
12	3	
12	8	
12	10	
14	4	
14	5	
14	12	
14	15	
14	18	
14	19	
16	08	
16	26	
18	08	
18	11	
18	32	
20	16	
20	39	
20	41	
22	12	
22	21	
22	41	
22	55	
24	19	
24	31	
24	61	

4.5.3.4 Types of Contact

The contact types shall be indicated by the following letters:-

Letter Code	Contact Type
P	Male
S	Female

4.5.3.5 Insert Clocking Position

Insert clocking positions are as shown in Figure 2(c) and shall be designated by the letter codes: N, W, X, Y and Z.



4.5.3.6 Modification Codes

Modification codes shall be expressed in letters or numbers, or both. They shall be defined by the Manufacturer, who shall keep a code register for reference purposes. When there is no modification of the standard product, no code shall appear. Black anodise treatment shall be identified by code 031.

These high reliability connectors are ordered separately from the contacts and this is specified by code 090. This code shall never appear on the connector itself, but shall be used in paperwork only.

4.5.4 Traceability Information

Traceability information shall be marked in accordance with the requirements of ESA/SCC Basic Specification No. 21700.

4.5.5 Marking of Small Components

Where it is considered that a component is too small to accommodate the marking as specified above, as much as space permits shall be marked. The order of precedence shall be as specified in Para. 4.5.1. The marking information in full shall accompany each component in its primary package.

4.6 ELECTRICAL MEASUREMENTS

4.6.1 Electrical Measurements at Room Temperature

The parameters to be measured in respect of electrical characteristics are scheduled in Table 2. Unless otherwise specified, the measurements shall be performed at $T_{amb} = +22 \pm 3$ °C.

4.6.2 Electrical Measurements at High and Low Temperatures (Table 3)

Not applicable.

4.6.3 Circuits for Electrical Measurements

Not applicable.

4.7 SCREENING TESTS (TABLES 4 AND 5)

Not applicable.



4.8 ENVIRONMENTAL AND ENDURANCE TESTS

4.8.1 Electrical Measurements on Completion of Environmental Tests

The parameters to be measured on completion of environmental tests shall be specified in the test sequence of ESA/SCC Generic Specification No. 3401. Unless otherwise stated, the measurements shall be performed at $T_{amb} = +22 \pm 3$ °C.

4.8.2 Electrical Measurements at Intermediate Points during Endurance Tests

Not applicable.

4.8.3 Electrical Measurements on Completion of Endurance Tests

The parameters to be measured on completion of endurance testing shall be those specified in Table 6 and the test sequence of ESA/SCC Generic Specification No. 3401. Unless otherwise stated, the measurements shall be performed at $T_{amb} = +22 \pm 3$ °C.

4.8.4 Conditions for Operating Life Tests (Part of Endurance Testing)

Not applicable.

4.8.5 Electrical Circuits for Operating Life Tests

Not applicable.

4.8.6 Conditions for High Temperature Storage Test (Part of Endurance Testing)

The requirements for the high temperature storage test are specified in Section 9 of ESA/SCC Generic Specification No. 3401. The conditions for high temperature storage shall be $T_{amb} = +200(+0 - 3)$ °C.

**SCC**ESA/SCC Detail Specification
No. 3401/007

PAGE 19

ISSUE 1

TABLE 2 - ELECTRICAL MEASUREMENTS AT ROOM TEMPERATURE

No.	CHARACTERISTICS	SYMBOL	SPEC. AND/OR TEST METHOD	TEST CONDITIONS	LIMITS		UNIT
					MIN.	MAX.	
1	Insulation Resistance	I_R	MIL-STD-202 Method 302	B	10 000	-	M Ω
2	Voltage Proof	V_P	MIL-STD-1344 Method 3001	-	1 500	-	Vrms

TABLE 6 - ELECTRICAL MEASUREMENTS AFTER ENVIRONMENTAL AND ENDURANCE TESTS

No.	CHARACTERISTICS	SYMBOL	SPEC. AND/OR TEST METHOD	TEST CONDITIONS	LIMITS		UNIT
					MIN.	MAX.	
1	Insulation Resistance	I_R	MIL-STD-202 Method 302	B	500	-	M Ω
2	Contact Resistance	R_C	ESA/SCC Gen. Spec. No. 3401 Para. 9.28	ESA/SCC Detail Spec. No. 3401/009			m Ω