



Pages 1 to 29

**CONTACTS, ELECTRICAL, CRIMP, WIRE-WRAP,
SOLDER AND SAVER
FOR 3401/016 CONNECTORS**

ESCC Detail Specification No. 3401/017

ISSUE 3

December 2006



Document Custodian: European Space Agency - see <https://escies.org>

| | | | |
|---|---|--|-------------------|
|  | ESCC Detail Specification No. 3401/017 | | PAGE 2 ISSUE 3 |
|---|---|--|-------------------|

LEGAL DISCLAIMER AND COPYRIGHT

European Space Agency, Copyright © 2006. All rights reserved.

The European Space Agency disclaims any liability or responsibility, to any person or entity, with respect to any loss or damage caused, or alleged to be caused, directly or indirectly by the use and application of this ESCC publication.

This publication, without the prior permission of the European Space Agency and provided that it is not used for a commercial purpose, may be:

- copied in whole in any medium without alteration or modification.
- copied in part, in any medium, provided that the ESCC document identification, comprising the ESCC symbol, document number and document issue, is removed.



ESCC Detail Specification
No. 3401/017

PAGE 3

ISSUE 3

DOCUMENTATION CHANGE NOTICE

(Refer to <https://escies.org> for ESCC DCR content)

| DCR No. | CHANGE DESCRIPTION |
|---------|--|
| 222 | Specification upissued to incorporate technical changes per DCR. |

| | | | |
|--|---|--|---------------------------|
|  | <p style="text-align: center;">ESCC Detail Specification No. 3401/017</p> | | <p>PAGE 4 ISSUE 3</p> |
|--|---|--|---------------------------|

TABLE OF CONTENTS

| | | <u>Page</u> |
|--------|--|-------------|
| 1. | <u>GENERAL</u> | 6 |
| 1.1 | Scope | 6 |
| 1.2 | Component Type Variants | 6 |
| 1.3 | Maximum Ratings | 6 |
| 1.4 | Parameter Derating Information | 6 |
| 1.5 | Physical Dimensions | 6 |
| 2. | <u>APPLICABLE DOCUMENTS</u> | 6 |
| 3. | <u>TERMS, DEFINITIONS, ABBREVIATIONS, SYMBOLS AND UNITS</u> | 6 |
| 4. | <u>REQUIREMENTS</u> | 23 |
| 4.1 | General | 23 |
| 4.2 | Deviations from Generic Specification | 23 |
| 4.2.1 | Deviations from Special In-process Controls | 23 |
| 4.2.2 | Deviations from Final Production Tests | 23 |
| 4.2.3 | Deviations from Burn-in and Electrical Measurements | 23 |
| 4.2.4 | Deviations from Qualification Tests | 23 |
| 4.2.5 | Deviations from Lot Acceptance Tests | 23 |
| 4.3 | Mechanical Requirements | 23 |
| 4.3.1 | Dimension Check | 23 |
| 4.3.2 | Weight | 23 |
| 4.3.3 | Contact Capability | 23 |
| 4.3.4 | Contact Retention | 23 |
| 4.3.5 | Mating and Unmating Forces | 24 |
| 4.3.6 | Insert Retention | 24 |
| 4.3.7 | Jackscrew Retention | 24 |
| 4.3.8 | Contact Insertion and Withdrawal Forces | 24 |
| 4.3.9 | Engagement and Separation Forces | 24 |
| 4.3.10 | Oversize Pin Exclusion | 24 |
| 4.3.11 | Probe Damage | 24 |
| 4.3.12 | Solderability | 24 |
| 4.4 | Materials and Finishes | 24 |
| 4.4.1 | Shells | 24 |
| 4.4.2 | Inserts | 24 |
| 4.4.3 | Contacts | 24 |
| 4.4.4 | Contact Retaining Clip | 25 |
| 4.4.5 | Guiding and Locking Devices | 25 |
| 4.4.6 | Magnetism Level | 25 |
| 4.5 | Marking | 25 |
| 4.5.1 | General | 25 |
| 4.5.2 | The ESCC Component Number | 25 |
| 4.5.3 | Traceability Information | 25 |
| 4.6 | Electrical Measurements | 26 |
| 4.6.1 | Electrical Measurements at Room Temperature | 26 |
| 4.6.2 | Electrical Measurements at High and Low Temperatures | 26 |
| 4.6.3 | Circuits for Electrical Measurements | 26 |
| 4.7 | Burn-in and Electrical Measurements | 26 |
| 4.8 | Environmental and Endurance Tests | 26 |
| 4.8.1 | Measurements and Inspections on Completion of Environmental Tests | 26 |
| 4.8.2 | Measurements and Inspections at Intermediate Points during Endurance Tests | 26 |
| 4.8.3 | Measurements and Inspections on Completion of Endurance Tests | 26 |
| 4.8.4 | Conditions for Operating Life Tests | 26 |

| | | | |
|---|---|--|---------------------------|
|  | <p style="text-align: center;">ESCC Detail Specification No. 3401/017</p> | | <p>PAGE 5 ISSUE 3</p> |
|---|---|--|---------------------------|

| | | |
|-------|--|-------------------|
| 4.8.5 | Electrical Circuit for Operating Life Tests | <u>Page</u> 26 |
| 4.8.6 | Conditions for High Temperature Storage Test | 26 |

TABLES

| | | |
|------|---|-----|
| 1(a) | Type Variants | 7 |
| 1(b) | Maximum Ratings | 10 |
| 2 | Electrical Measurements at Room Temperature | 27 |
| 3 | Not applicable | N/A |
| 4 | Not applicable | N/A |
| 5 | Not applicable | N/A |
| 6 | Measurements and Inspections on Completion of Environmental and Endurance Testing | 28 |

FIGURES

| | | |
|---|--------------------------------|-----|
| 1 | Parameter Derating Information | N/A |
| 2 | Physical Dimensions | 11 |

APPENDICES (Applicable to specific Manufacturers only)

None.



1. **GENERAL**

1.1 **SCOPE**

This specification details the ratings, physical and electrical characteristics, test and inspection data for Contacts, Electrical, Crimp, Wire-Wrap, Solder and Saver, Gauge 0.6mm, for 3401/016 Connectors.

This specification shall be read in conjunction with:

- ESCC Generic Specification No. 3401, Connectors, Electrical, Non-Filtered, Circular and Rectangular,
- ESCC Detail Specification No. 3401/016, Connectors, Electrical, Printed Circuit Board, Removable Contacts, Crimp, Wire-Wrap, Solder and Saver, based on Type HE801,

the requirements of which are supplemented herein.

1.2 **COMPONENT TYPE VARIANTS**

The different types of contacts specified herein, which are also covered by this specification are scheduled in Table 1(a).

1.3 **MAXIMUM RATINGS**

The maximum ratings, which shall not be exceeded at any time during use or storage, applicable to the contacts specified herein, are scheduled in Table 1(b).

1.4 **PARAMETER DERATING INFORMATION (FIGURE 1)**

Not applicable.

1.5 **PHYSICAL DIMENSIONS**

The physical dimensions of the contacts specified herein are shown in Figure 2.

2. **APPLICABLE DOCUMENTS**

The following documents form part of this specification and shall be read in conjunction with it:-

- (a) ESCC Generic Specification No. 3401, Connectors, Electrical, Non-Filtered, Circular and Rectangular.
- (b) ESCC Detail Specification No. 3401/016, Connectors, Electrical, for Printed Circuit Boards, Removable Contacts, Crimp, Wire-Wrap, Solder and Saver, based on Type HE801.

3. **TERMS, DEFINITIONS, ABBREVIATIONS, SYMBOLS AND UNITS**

For the purpose of this specification, the terms, definitions, abbreviations, symbols and units specified in ESCC Basic Specification No. 21300 shall apply.



ESCC Detail Specification
No. 3401/017

TABLE 1(a) - TYPE VARIANTS

| VAR- IANT | TYPE | MATING END SIZE Ø mm | BARREL SIZE | RATED CUR- RENT MAX | ACCEPT WIRE | MAX WEIGHT | ENGAGEMENT & SEPARATION | | TEST PINS | | | CONTACT CAPABILITY | | CON- TACT RETENT. FORCE MAX | CONTACT INSERT WITHDR FORCES MAX | PROBE DAMAGE | | OVERSIZE PIN EXCL. | | |
|--------------|----------------|----------------------------------|----------------|------------------------------|----------------|---------------|----------------------------|---------------------------|----------------|----------------|---------------------|--------------------|---------------------|---|--|-----------------|--------------|--------------------|-------|-------|
| | | | | | | | ENGAG. FORCES N (1) | SEPAR. FORCES N (1) | min. | max. | Pick-up (2) g | Drop (3) g | MO- MENT N.cm | | | PROBE DIA mm | FORCE MAX | TEST PIN DIA mm | min | max |
| 01 (6) | MC | 0.6 | N/A | 5.0 | N/A | 0.18 | - | - | - | - | - | - | - | 20 | - | - | - | - | - | |
| 02 (6) | MC | 0.6 | N/A | 5.0 | N/A | 0.21 | - | - | - | - | - | - | - | 20 | - | - | - | - | - | |
| 03 (6) | MC | 0.6 | N/A | 5.0 | N/A | 0.22 | - | - | - | - | - | - | - | 20 | - | - | - | - | - | |
| 04 | MR | 0.6 | 22 | 5.0 | 22-24 26 | 0.20 | - | - | - | - | - | - | - | 20 | - | - | - | - | - | |
| 05 (6) | NOT TO BE USED | | | | | | | | | | | | | | | | | | | |
| 06 (6) | MD | 0.6 | N/A | 5.0 | N/A | 0.18 | - | - | - | - | - | - | - | 20 | - | - | - | - | - | |
| 07 (6) | MD | 0.6 | N/A | 5.0 | N/A | 0.18 | - | - | - | - | - | - | - | 20 | - | - | - | - | - | |
| 08 (6) | MS | 0.6 | 22 | 5.0 | 22 24 | 0.22 | - | - | - | - | - | - | - | 20 | - | - | - | - | - | |
| 10 (6) | MY | 0.6 | N/A | 5.0 | 26-28 30 | 0.29 | - | - | - | - | - | - | - | 20 | - | - | - | - | - | |
| 11 (6) | MY | 0.6 | N/A | 5.0 | 26-28 30 | 0.21 | - | - | - | - | - | - | - | 20 | - | - | - | - | - | |
| 12 (6) | FC | 0.6 | N/A | 5.0 | N/A | 0.125 | 0.90 | 0.14 | 0.620 0.575 | 0.625 0.580 | - 14 | 90 | 40 (4) 25 (5) | 20 | 0.5 | 0.59 | 0.61 | 0.9 | 0.758 | 0.762 |

NOTES: See Page 8.



ESCC Detail Specification
No. 3401/017

TABLE 1(a) - TYPE VARIANTS

| VAR- IANT | TYPE | MATING END SIZE Ø mm | BARREL SIZE | RATED CUR- RENT MAX A | ACCEPT WIRE AWG | MAX WEIGHT g | ENGAGEMENT & SEPARATION | | | CONTACT CAPABILITY | | | CON- TACT RETENT. FORCE MAX N | CON- TACT INSERT WITHDR FORCES MAX N | PROBE DAMAGE | | | OVERSIZE PIN EXCL. | | |
|--------------|----------------|----------------------------------|----------------|-----------------------------------|-----------------------|--------------------|----------------------------|---------------------------|---------------------|--------------------|---------|---------------------|--|--|---------------------|------------------|-------------------|--------------------|-------|-----|
| | | | | | | | ENGAG. FORCES N (1) | SEPAR. FORCES N (1) | TEST PINS DIA mm | WEIGHT | | MO- MENT N.cm | | | PROBE DIA mm | | FORCE MAX N | TEST PIN DIA mm | | |
| | | | | | | | | | | min. | max. | | | | Pick-up (2) g | Drop (3) g | | min | max | min |
| 13 (6) | FC | 0.6 | N/A | 5.0 | N/A | 0.15 | 0.90 | 0.90 | 0.620 0.575 | 0.625 0.580 | - 14 | 90 | - | 0.5 | 0.59 | 0.61 | 0.9 | 0.758 | 0.762 | |
| 14 (6) | FC | 0.6 | N/A | 5.0 | N/A | 0.155 | 0.90 | 0.90 | 0.620 0.575 | 0.625 0.580 | - 14 | 90 | - | 0.5 | 0.59 | 0.61 | 0.9 | 0.758 | 0.762 | |
| 15 | FR | 0.6 | 22 | 5.0 | 22-24 26 | 0.145 | 0.90 | 0.90 | 0.620 0.575 | 0.625 0.580 | - 14 | 90 | - | 0.5 | 0.59 | 0.61 | 0.9 | 0.758 | 0.762 | |
| 16 (6) | NOT TO BE USED | | | | | | | | | | | | | | | | | | | |
| 17 (6) | FD | 0.6 | N/A | 5.0 | N/A | 0.12 | 0.90 | 0.90 | 0.620 0.575 | 0.625 0.580 | - 14 | 90 | - | 0.5 | 0.59 | 0.61 | 0.9 | 0.758 | 0.762 | |
| 18 (6) | FD | 0.6 | N/A | 5.0 | N/A | 0.12 | 0.90 | 0.90 | 0.620 0.575 | 0.625 0.580 | - 14 | 90 | - | 0.5 | 0.59 | 0.61 | 0.9 | 0.758 | 0.762 | |
| 19 (6) | FS | 0.6 | 22 | 5.0 | 22-24 | 0.165 | 0.90 | 0.90 | 0.620 0.575 | 0.625 0.580 | - 14 | 90 | - | 0.5 | 0.59 | 0.61 | 0.9 | 0.758 | 0.762 | |
| 21 (6) | FY | 0.6 | N/A | 5.0 | 26-28 30 | 0.16 | 0.90 | 0.90 | 0.620 0.575 | 0.625 0.580 | - 14 | 90 | - | 0.5 | 0.59 | 0.61 | 0.9 | 0.758 | 0.762 | |
| 22 (6) | FY | 0.6 | N/A | 5.0 | 26-28 30 | 0.155 | 0.90 | 0.90 | 0.620 0.575 | 0.625 0.580 | - 14 | 90 | - | 0.5 | 0.59 | 0.61 | 0.9 | 0.758 | 0.762 | |
| 64 (6) | ML | 0.6 | N/A | 5.0 | N/A | 0.19 | - | - | - | - | - | - | - | - | - | - | - | - | - | |
| 65 (6) | ML | 0.6 | N/A | 5.0 | N/A | 0.21 | - | - | - | - | - | - | - | - | - | - | - | - | - | |

NOTES: See Page 8.



TABLE 1(a) - TYPE VARIANTS

| VAR- IANT | TYPE | MATING END SIZE Ø mm | BARREL SIZE | RATED CUR- RENT MAX | ACCEPT WIRE | MAX WEIGHT | ENGAGEMENT & SEPARATION | | TEST PINS | | | CONTACT CAPABILITY | | | CON- TACT RETENT. FORCE MAX | CON- TACT INSERT WITHDR FORCES MAX | PROBE DAMAGE | | OVERSIZE PIN EXCL. | |
|--------------|------|----------------------------------|----------------|------------------------------|----------------|---------------|----------------------------|---------------------------|-----------|-------|---------------------|--------------------|-------------|-----------------|---|---|--------------|--------------------|--------------------|-------|
| | | | | | | | ENGAG. FORCES N (1) | SEPAR. FORCES N (1) | DIA mm | | Pick-up (2) g | Drop (3) g | MO- MENT | PROBE DIA mm | | | FORCE MAX | TEST PIN DIA mm | | |
| | | | | | | | | | min. | max. | | | | min | | | | max | min | max |
| 66 (6) | ML | 0.6 | N/A | 5.0 | N/A | 0.24 | - | - | - | - | - | - | - | - | 20 | - | - | - | - | - |
| 67 (6) | FM | 0.6 | N/A | 5.0 | N/A | 0.12 | 0.90 | 0.90 | 0.620 | 0.625 | - | 90 | 90 | 0.5 | 20 | 0.59 | 0.61 | 0.758 | 0.762 | 0.762 |
| 68 (6) | FL | 0.6 | N/A | 5.0 | N/A | 0.125 | - | 0.14 | 0.575 | 0.580 | 14 | - | 25 | 20 | 0.5 | 0.59 | 0.61 | 0.758 | 0.762 | 0.762 |
| 69 (6) | FL | 0.6 | N/A | 5.0 | N/A | 0.135 | 0.90 | 0.14 | 0.620 | 0.625 | - | 90 | 90 | 0.5 | 20 | 0.59 | 0.61 | 0.758 | 0.762 | 0.762 |
| 70 (6) | FL | 0.6 | N/A | 5.0 | N/A | 0.16 | - | 0.14 | 0.575 | 0.580 | 14 | - | 25 | 20 | 0.5 | 0.59 | 0.61 | 0.758 | 0.762 | 0.762 |

NOTES

1. 1st line, maximum values with maximum diameter test pin;
2nd line, minimum values with minimum diameter test pin.
2. With minimum diameter test pin and minimum insertion depth of 5.0mm.
3. With maximum diameter test pin and minimum insertion depth of 5.0mm.
4. Tension.
5. Compression.
6. These variants are delivered mounted in the inserts and dimensions of the rear part are given in ESCC Detail Specification No. 3401/016.

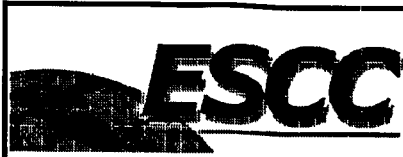

TABLE 1(b) - MAXIMUM RATINGS

| No. | CHARACTERISTICS | SYMBOL | MAXIMUM RATING | UNIT | REMARKS |
|-----|-----------------------------|-----------|----------------|------|---------|
| 1 | Rated Current | I_{CR} | See Table 1(a) | A | |
| 2 | Operating Temperature Range | T_{op} | - 55 to + 125 | °C | |
| 3 | Storage Temperature Range | T_{stg} | - 55 to + 125 | °C | |
| 4 | Soldering Temperature | T_{sol} | + 260 | °C | Note 1 |

NOTES

1. Duration 10 seconds maximum and the same contact shall not be resoldered until 3 minutes have elapsed.

FIGURE 1 - PARAMETER DERATING INFORMATION

Not applicable.

FIGURE 2 - PHYSICAL DIMENSIONS

VARIANT 01 - SOLDER RIGHT-ANGLE MALE CONTACT

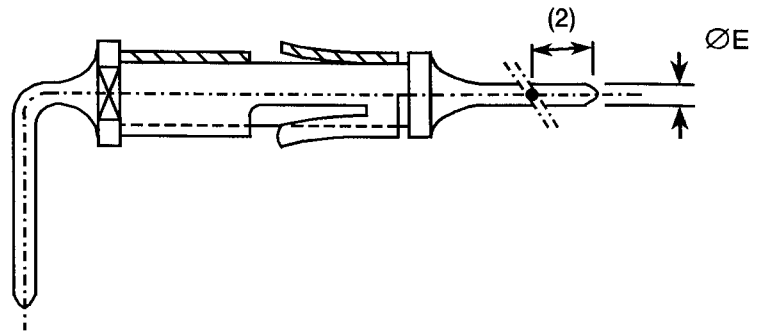

VARIANT 02 - SOLDER RIGHT-ANGLE MALE CONTACT

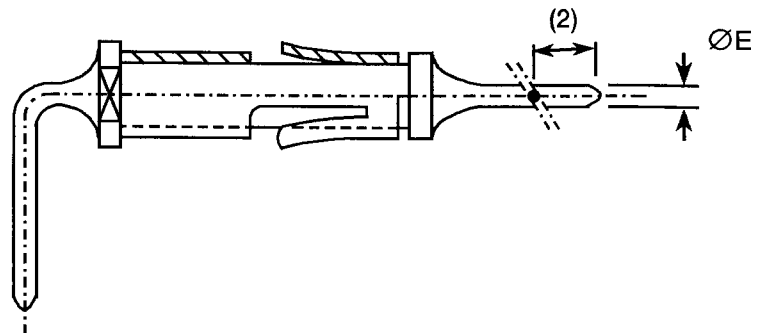

| SYMBOL | MILLIMETRES | |
|--------|-------------|------|
| | MIN. | MAX. |
| ØE | 0.58 | 0.62 |

NOTES

1. All dimensions are in millimetres.
2. Measurement point for plating thickness: 2.0 ± 1.0 mm.

FIGURE 2 - PHYSICAL DIMENSIONS (CONTINUED)

VARIANT 03 - SOLDER RIGHT-ANGLE MALE CONTACT

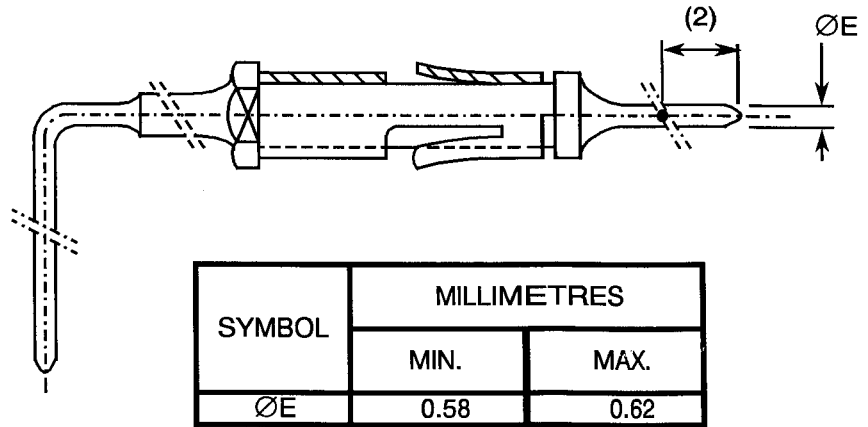

VARIANT 04 - CRIMP MALE CONTACT

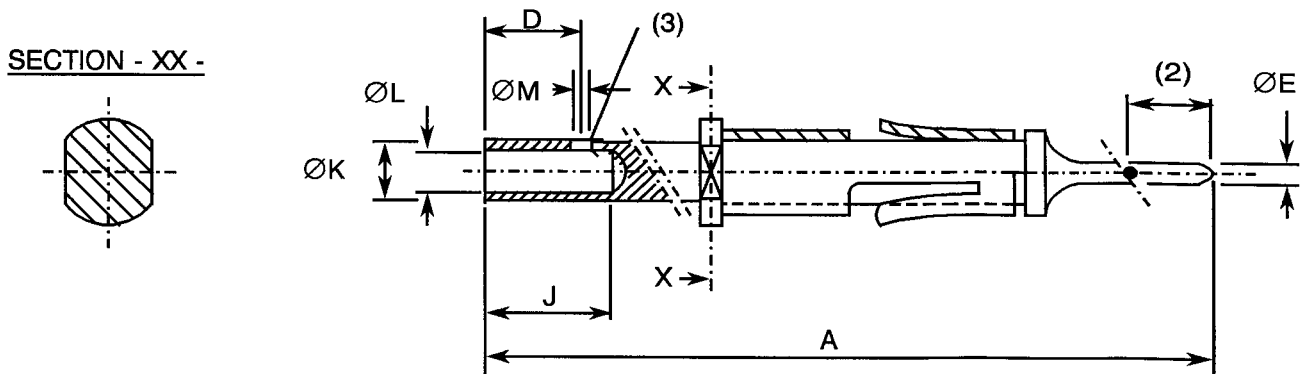

| SYMBOL | MILLIMETRES | |
|--------|-------------|-------|
| | MIN. | MAX. |
| A | 16.30 | 17.10 |
| D | 3.20 | 4.10 |
| ØE | 0.58 | 0.62 |
| J | 3.80 | - |
| ØK | 1.23 | 1.50 |
| ØL | 0.85 | 0.95 |
| ØM | 0.40 | 0.60 |

NOTES

1. All dimensions are in millimetres.
2. Measurement point for plating thickness: 2.0 ± 1.0 mm.
3. Inspection hole shall only penetrate one wall of the crimp barrel.

FIGURE 2 - PHYSICAL DIMENSIONS (CONTINUED)

VARIANT 05 - NOT TO BE USED

VARIANT 06 - SOLDER STRAIGHT-THROUGH MALE CONTACT

(Not to be used for new design)

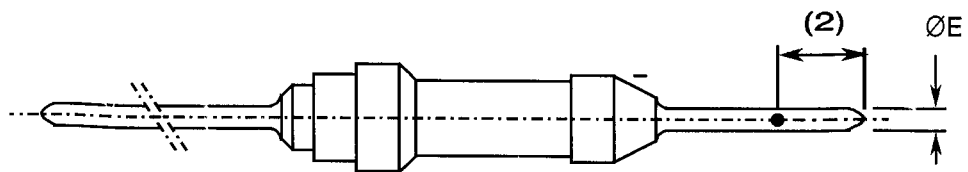

| SYMBOL | MILLIMETRES | |
|--------|-------------|------|
| | MIN. | MAX. |
| ØE | 0.58 | 0.62 |

NOTES

1. All dimensions are in millimetres.
2. Measurement point for plating thickness: 2.0 ± 1.0 mm.

FIGURE 2 - PHYSICAL DIMENSIONS (CONTINUED)

VARIANT 07 - SOLDER STRAIGHT-THROUGH MALE CONTACT

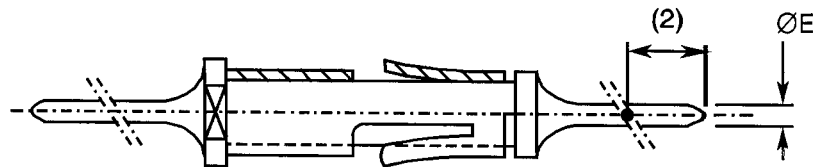

VARIANT 08 - SOLDER BUCKET MALE CONTACT

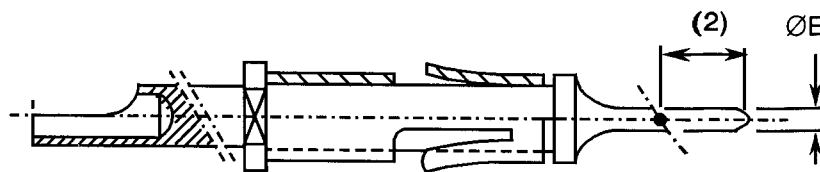

VARIANT 10 - WIRE-WRAP MALE CONTACT

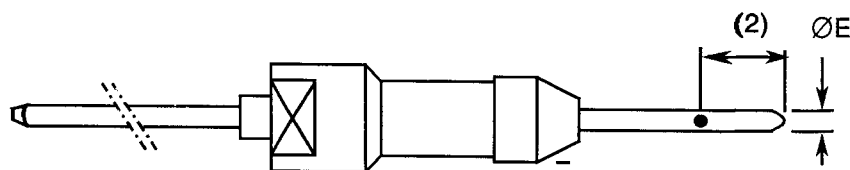

| SYMBOL | MILLIMETRES | |
|--------|-------------|------|
| | MIN. | MAX. |
| ØE | 0.58 | 0.62 |

NOTES

1. All dimensions are in millimetres.
2. Measurement point for plating thickness: 2.0 ± 1.0 mm.

FIGURE 2 - PHYSICAL DIMENSIONS (CONTINUED)

VARIANT 11 - WIRE-WRAP MALE CONTACT

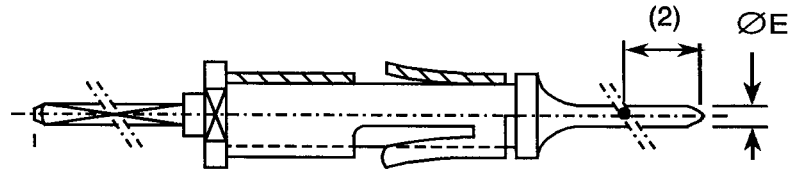

| SYMBOL | MILLIMETRES | |
|--------|-------------|------|
| | MIN. | MAX. |
| ØE | 0.58 | 0.62 |

NOTES

1. All dimensions are in millimetres.
2. Measurement point for plating thickness: 2.0 ± 1.0 mm.

VARIANT 12 - SOLDER RIGHT-ANGLE FEMALE CONTACT

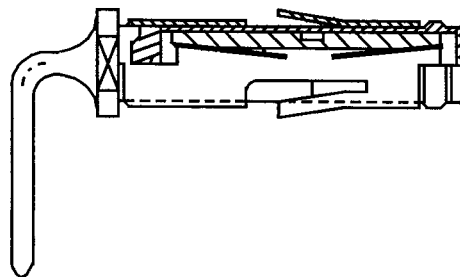
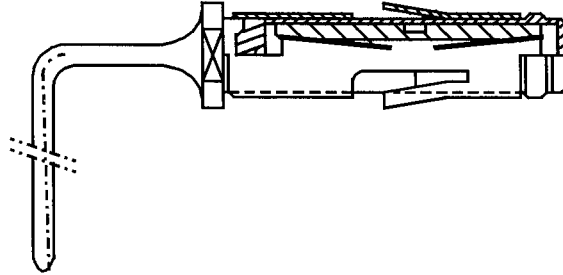



FIGURE 2 - PHYSICAL DIMENSIONS (CONTINUED)

VARIANT 13 - SOLDER RIGHT-ANGLE FEMALE CONTACT



VARIANT 14 - SOLDER RIGHT-ANGLE FEMALE CONTACT

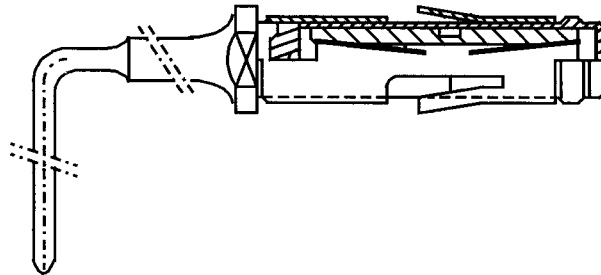
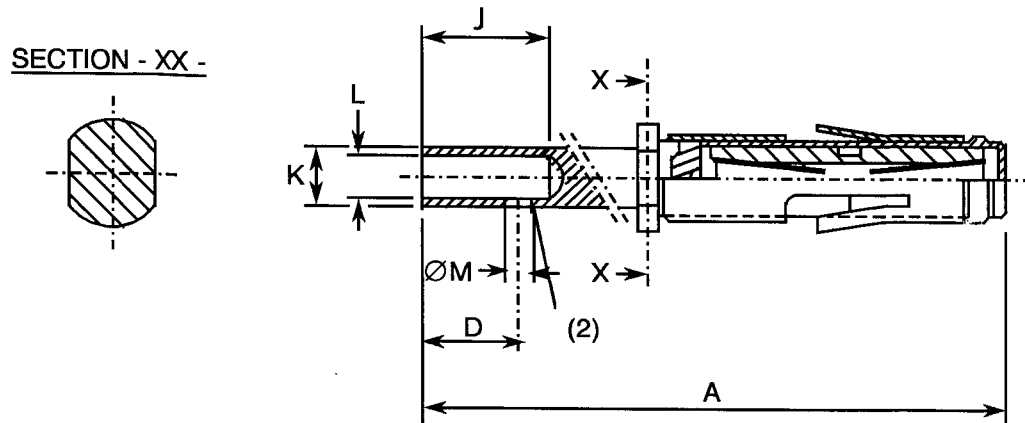

FIGURE 2 - PHYSICAL DIMENSIONS (CONTINUED)

VARIANT 15 - CRIMP FEMALE CONTACT



| SYMBOL | MILLIMETRES | |
|--------|-------------|-------|
| | MIN. | MAX. |
| A | 11.40 | 12.20 |
| D | 3.20 | 4.10 |
| J | 3.80 | - |
| K | 1.23 | 1.50 |
| L | 0.85 | 0.95 |
| ØM | 0.40 | 0.60 |

NOTES

1. All dimensions are in millimetres.
2. Inspection hole shall only penetrate one wall of the crimp barrel.

FIGURE 2 - PHYSICAL DIMENSIONS (CONTINUED)

VARIANT 16 - NOT TO BE USED

VARIANT 17 - SOLDER STRAIGHT-THROUGH FEMALE CONTACT

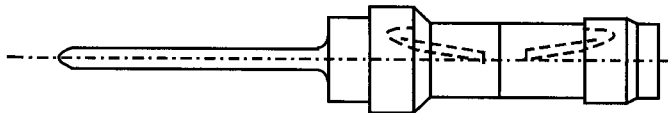
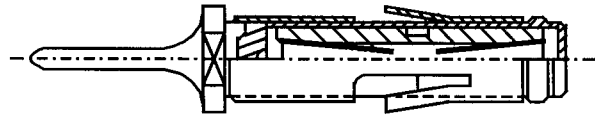
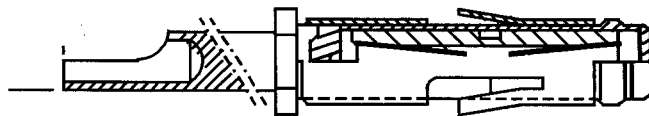

FIGURE 2 - PHYSICAL DIMENSIONS (CONTINUED)

VARIANT 18 - SOLDER STRAIGHT-THROUGH FEMALE CONTACT



VARIANT 19 - SOLDER BUCKET FEMALE CONTACT



VARIANT 21 - WIRE-WRAP FEMALE CONTACT

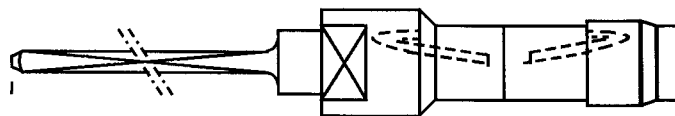

VARIANT 22 - WIRE-WRAP FEMALE CONTACT

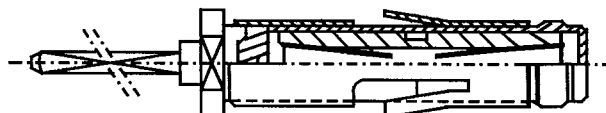
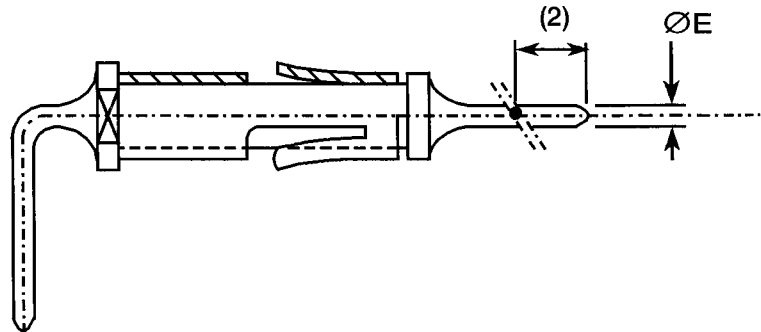
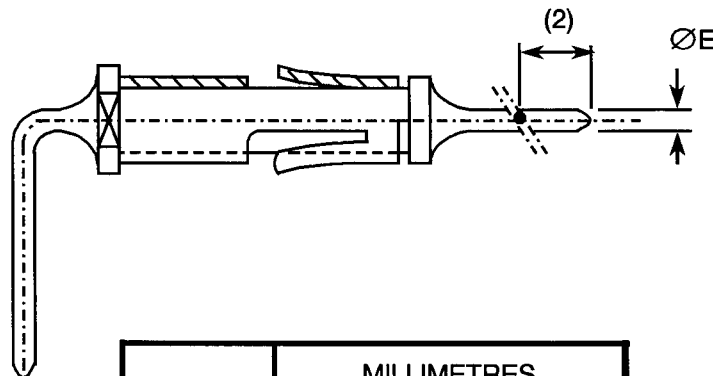

FIGURE 2 - PHYSICAL DIMENSIONS (CONTINUED)

VARIANT 64 - SOLDER RIGHT-ANGLE MALE CONTACT (LONG)



VARIANT 65 - SOLDER RIGHT-ANGLE MALE CONTACT (LONG)



| SYMBOL | MILLIMETRES | |
|--------|-------------|------|
| | MIN. | MAX. |
| ØE | 0.58 | 0.62 |

NOTES

1. All dimensions are in millimetres.
2. Measurement point for plating thickness: 2.0 ± 1.0 mm.

FIGURE 2 - PHYSICAL DIMENSIONS (CONTINUED)

VARIANT 66 - SOLDER RIGHT-ANGLE MALE CONTACT

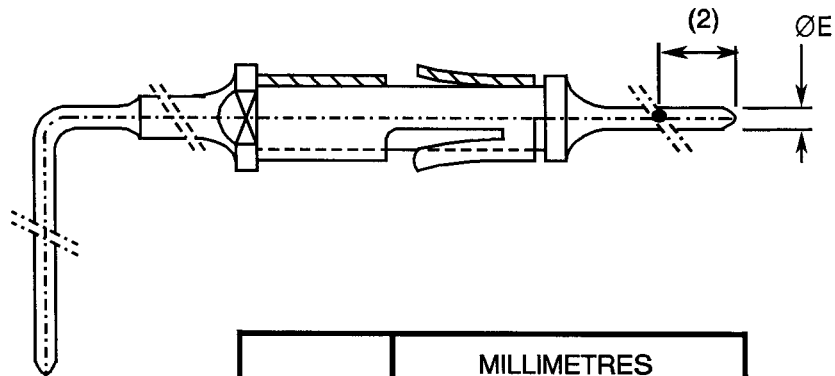

| SYMBOL | MILLIMETRES | |
|--------|-------------|------|
| | MIN. | MAX. |
| ØE | 0.58 | 0.62 |

VARIANT 67 - SAVER FEMALE - MALE CONTACT

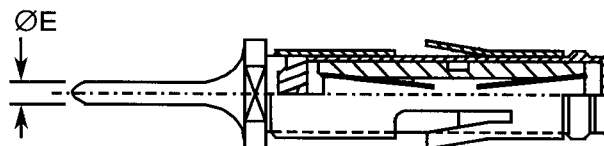

NOTES

1. All dimensions are in millimetres.
2. Measurement point for plating thickness: 2.0 ± 1.0 mm.

FIGURE 2 - PHYSICAL DIMENSIONS (CONTINUED)

VARIANT 68 - SOLDER RIGHT-ANGLE FEMALE CONTACT

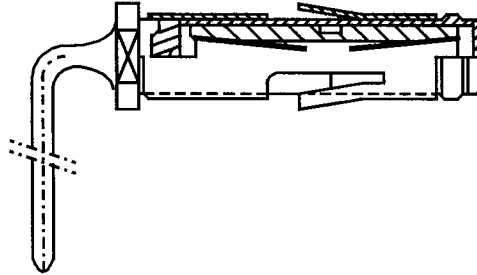

VARIANT 69 - SOLDER RIGHT-ANGLE FEMALE CONTACT

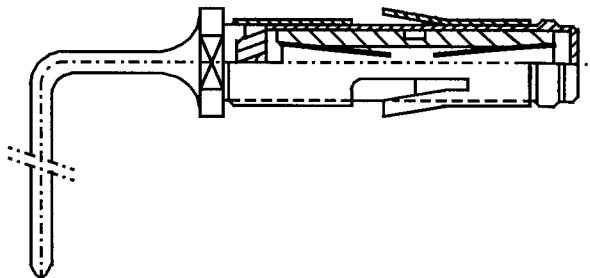

VARIANT 70 - SOLDER RIGHT-ANGLE FEMALE CONTACT

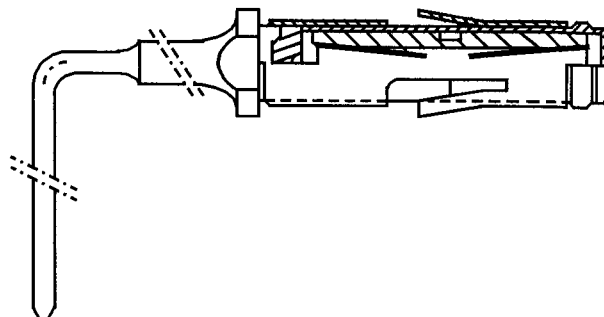

| | | |
|---|---|---|
|  | <p style="text-align: center;">ESCC Detail Specification No. 3401/017</p> | <p style="text-align: right;">PAGE 23 ISSUE 3</p> |
|---|---|---|

4. REQUIREMENTS

4.1 GENERAL

The complete requirements for procurement of the contacts specified herein are stated in this specification and ESCC Generic Specification No. 3401. Deviations from the Generic Specification, applicable to this specification only, are listed in Para. 4.2.

Deviations from the applicable Generic Specification and this Detail Specification, formally agreed with specific Manufacturers on the basis that the alternative requirements are equivalent to the ESCC requirements and do not affect the components' reliability, are listed in the appendices attached to this specification.

4.2 DEVIATIONS FROM GENERIC SPECIFICATION

4.2.1 Deviations from Special In-process Controls

None.

4.2.2 Deviations from Final Production Tests (Chart II)

(a) Para. 9.4, Contact Capability: Sampling in accordance with Para. 9.6 of ESCC 3401.

4.2.3 Deviations from Burn-in and Electrical Measurements (Chart III)

Not applicable.

4.2.4 Deviations from Qualification Tests (Chart IV)

(a) Para. 9.22, Corrosion: Not applicable.

(b) Para. 9.31, Solderability: Not applicable to Variants 04, 10, 11, 15, 21 and 22.

4.2.5 Deviations from Lot Acceptance Tests (Chart V)

(a) Para. 9.22, Corrosion: Not applicable.

(b) Para. 9.31, Solderability: Not applicable to Variants 04, 10, 11, 15, 21 and 22.

4.3 MECHANICAL REQUIREMENTS

4.3.1 Dimension Check

The dimensions of the contacts specified herein shall be verified in accordance with the requirements set out in Para. 9.6 of ESCC Generic Specification No. 3401 and shall conform to those shown in Figure 2 of this specification. Overall dimensions are specified with compatible inserts in ESCC Detail specification No. 3401/016.

4.3.2 Weight

The maximum weight of the contacts specified herein shall be as specified in Table 1 (a).

4.3.3 Contact Capability

For the purpose of this test, the pick-up and drop weights shall be as specified in Table 1(a).

4.3.4 Contact Retention (in insert)

The contact retention force shall be as specified in Table 1(a).

| | | |
|---|---|---|
|  | <p style="text-align: center;">ESCC Detail Specification No. 3401/017</p> | <p style="text-align: right;">PAGE 24 ISSUE 3</p> |
|---|---|---|

4.3.5 Mating and Unmating Forces

As specified in ESCC Detail Specification No. 3401/016.

4.3.6 Insert Retention (In Shell)

As specified in ESCC Detail Specification No. 3401/016.

4.3.7 Jackscrew Retention

As specified in ESCC Detail Specification No. 3401/016.

4.3.8 Contact Insertion and Withdrawal Forces

The contact insertion and withdrawal forces shall be as specified in Table 1(a).

4.3.9 Engagement and Separation Forces

The diameter of the test pin and the engagement and separation forces of the female contacts shall be as specified in Table 1(a).

4.3.10 Oversize Pin Exclusion

The diameter of the test pin and the force applied to it shall be as specified in Table 1(a).

4.3.11 Probe Damage

The probe diameter and the moment at the end of the probe shall be as specified in Table 1(a).

4.3.12 Solderability

Not applicable to Variants 04, 10, 11, 15, 21 and 22. For all other variants, size B soldering iron shall be used.

4.4 MATERIALS AND FINISHES

The materials and finishes shall be as specified herein. Where a definite material is not specified, a material which will enable the contacts specified herein to meet the performance requirements of this specification shall be used. Acceptance or approval of any constituent material does not guarantee acceptance of the finished product.

4.4.1 Shells

As specified in ESCC Detail Specification No. 3401/016.

4.4.2 Inserts

As specified in ESCC Detail Specification No. 3401/016.

4.4.3 Contacts

4.4.3.1 Body

The contact body shall be made of copper alloy.

- Male Contact and Saver

The plating shall be 1.27µm minimum gold over 1.27µm minimum nickel.

- Female Contact

The plating shall be 0.25µm minimum gold over 1.27µm minimum nickel.

4.4.3.2 Female Contact Wire

The wire shall be made of copper alloy.

The plating shall be 1.27µm minimum gold over 0.20µm minimum nickel.

4.4.3.3 Female Contact Sleeve

The sleeve shall be made of copper alloy. The plating shall be 0.25µm minimum gold over 0.8µm minimum nickel.

4.4.4 Contact Retaining Clip

The clip shall be made of a beryllium copper alloy.

4.4.5 Guiding and Locking Devices

As specified in ESCC Detail Specification No. 3401/016.

4.4.6 Magnetism Level

As specified in ESCC Detail Specification No. 3401/016.

4.5 MARKING

4.5.1 General

The marking of all components delivered to this specification shall be in accordance with the requirements of ESCC Basic Specification No. 21700 and the following paragraphs.

These components being too small to accommodate the marking as specified hereafter, the full marking information shall accompany each lot of components in its primary package. Such marking shall comprise:-

- (a) The ESCC Component Number.
- (b) Traceability information.

4.5.2 The ESCC Component Number

The ESCC Component Number shall be constituted and marked as follows:-

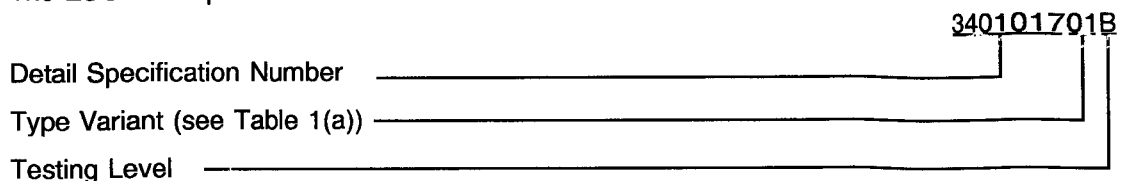

4.5.3 Traceability Information

Traceability information shall be marked in accordance with ESCC Basic Specification No. 21700.

| | | |
|---|---|---|
|  | <p style="text-align: center;">ESCC Detail Specification No. 3401/017</p> | <p style="text-align: right;">PAGE 26 ISSUE 3</p> |
|---|---|---|

4.6 ELECTRICAL MEASUREMENTS

4.6.1 Electrical Measurements at Room Temperature

The parameters to be measured in respect of electrical characteristics are scheduled in Table 2. Unless otherwise specified, the measurements shall be performed at $T_{amb} = +22 \pm 3$ °C.

4.6.2 Electrical Measurements at High and Low Temperatures (Table 3)

Not applicable.

4.6.3 Circuits for Electrical Measurements (Figure 4)

Not applicable.

4.7 BURN-IN AND ELECTRICAL MEASUREMENTS

Not applicable.

4.8 ENVIRONMENTAL AND ENDURANCE TESTS (CHARTS IV AND V OF ESCC GENERIC SPECIFICATION No. 3401)

4.8.1 Measurements and Inspections on Completion of Environmental Tests

The parameters to be measured and inspections to be performed on completion of environmental testing are scheduled in Table 6. Unless otherwise specified, the measurements shall be performed at $T_{amb} = +22 \pm 3$ °C.

4.8.2 Measurements and Inspections at Intermediate Points during Endurance Tests

Not applicable.

4.8.3 Measurements and Inspections on Completion of Endurance Tests

The parameters to be measured and inspections to be performed on completion of endurance testing are scheduled in Table 6. Unless otherwise specified, the measurements shall be performed at $T_{amb} = +22 \pm 3$ °C.

4.8.4 Conditions for Operating Life Tests (Part of Endurance Testing)

Not applicable.

4.8.5 Electrical Circuit for Operating Life Tests (Figure 5)

Not applicable.

4.8.6 Conditions for High Temperature Storage Test (Part of Endurance Testing)

The requirements for the high temperature storage test are specified in Section 9 of ESCC Generic Specification No. 3401. The conditions for high temperature storage testing shall be the maximum storage temperature specified in Table 1(b) of this specification.

TABLE 2 - ELECTRICAL MEASUREMENTS AT ROOM TEMPERATURE

| No. | CHARACTERISTICS | SYMBOL | SPEC. AND/OR TEST METHOD | TEST CONDITION | VARIANTS | LIMITS | | UNIT |
|-----|--|--------|-------------------------------|--------------------------|----------|--------|------|------|
| | | | | | | MIN. | MAX. | |
| 1 | Contact Resistance (Low Level Current) (1) | Rcl | ESCC No. 3401 Para 9.1.1.3 | Para 9.1.1.3 | All | - | 8.0 | mΩ |
| 2 | Contact Resistance (Rated Current) (1) | Rcr | ESCC No. 3401 Para 9.1.1.3 | Para 9.1.1.3 5.0A | All | - | 8.0 | mΩ |

NOTES

1. Contact Resistance at Low Level Current and at Rated Current is guaranteed but not tested during Final Production Tests (Chart II).

TABLES 3, 4 AND 5

Not applicable.

TABLE 6 - MEASUREMENTS AND INSPECTIONS ON COMPLETION OF ENVIRONMENTAL AND ENDURANCE TESTING

| NO. | ESCC GENERIC NO. 3401 | | MEASUREMENTS AND INSPECTIONS | | SYMBOL | LIMITS | | UNIT |
|-----|---------------------------------------|--|---|---------------------------|--------|--------------------------|-----|------|
| | ENVIRONMENTAL AND ENDURANCE TESTS (1) | TEST METHOD AND CONDITIONS | IDENTIFICATION | CONDITIONS | | MIN | MAX | |
| 01 | Seal Test | Para. 9.9 | ESCC 3401/016 | | | | | |
| 02 | Wiring | Para. 9.10 & Table 1(a) of this spec. | Low Level Contact Resistance | Table 2 Item 1 | Rcl | Table 2 Item 1 | | |
| 03 | Vibration | Para. 9.11 | ESCC 3401/016 | | | | | |
| 04 | Shock or Bump | Para. 9.12 | ESCC 3401/016 | | | | | |
| 05 | Climatic Sequence | Para. 9.13 | ESCC 3401/016 | | | | | |
| 06 | Plating Thickness | Para. 9.14 | Thickness | - | - | Para. 4.4.3 of this spec | | |
| 07 | Joint Strength | Para. 9.15 | ESCC 3401 Para 9.15 | | | | | |
| 08 | Rapid Change of Temperature | Para. 9.16 | ESCC 3401/016 | | | | | |
| 09 | Contact Retention (in insert) | Para. 9.17 & Para. 4.3.4 of this spec. | Contact Displacement | | - | ESCC 3401 Para. 9.17 | | |
| 10 | Endurance | Para. 9.18 | Initial Measurements Low Level Contact Resist | Table 2 Item 1 | Rcl | Record Values | | mΩ |
| | | | Final Measurements Low Level Contact Resistance Drift | Table 2 Item 1 | ΔRcl | - | 4.0 | |
| 11 | Permanence of Marking | Para. 9.19 | As applicable | | | | | |
| 12 | Mating/Unmating Forces | Para. 9.20 | ESCC 3401/016 | | | | | |
| 13 | High Temperature Storage | Para. 9.21 | Initial Measurements Low Level Contact Resist | Table 2 Item 1 | Rcl | Record Values | | mΩ |
| | | | Final Measurements Low Level Contact Resistance Drift | Table 2 Item 1 | ΔRcl | - | 4.0 | |
| | | | Rated Current Contact Resistance | Table 2 Item 2 | Rcr | Table 2 Item 2 | | |
| | | | Contact Retention (in insert) | Para. 4.3.4 of this spec. | - | ESCC 3401 Para. 9.17 | | |
| 14 | Corrosion | Para. 9.22 | Visual Examination | | | | | |

NOTES

1. The tests in this table refer to either Chart IV or V and shall be used as applicable.

TABLE 6 - MEASUREMENTS AND INSPECTIONS ON COMPLETION OF ENVIRONMENTAL AND ENDURANCE TESTING (CONTINUED)

| NO. | ESCC GENERIC NO. 3401 | | MEASUREMENTS AND INSPECTIONS | | SYMBOL | LIMITS | | UNIT |
|-----|---------------------------------------|---|--|---|-------------|--|-----|------|
| | ENVIRONMENTAL AND ENDURANCE TESTS (1) | TEST METHOD AND CONDITIONS | IDENTIFICATION | CONDITIONS | | MIN | MAX | |
| 15 | Insert Retention (in shell) | Para. 9.23 & Para. 4.3.6 of this spec. | ESCC 3401/016 | | | | | |
| 16 | Jackscrew Retention | Para. 9.24 & Para. 4.3.7 of this spec. | ESCC 3401/016 | | | | | |
| 17 | High Temperature Measurements | Para. 9.25 | ESCC 3401/016 | | | | | |
| 18 | Overload Test | Para. 9.26 | Rated Current Contact Resistance | Table 2 Item 2 | Rcr | Table 2 Item 2 | | |
| 19 | Maintenance Aging | Para. 9.27 | Visual Examination Contact Retention (in insert) Contact Insertion & Withdrawal Forces | - Para. 4.3.4 of this spec. Para. 4.3.8 of this spec. | - - - | - - ESCC 3401 Para. 9.17 Para. 4.3.8 | | |
| 20 | Engage/Separation Forces | Para. 9.28 & Para. 4.3.9 of this spec. | Force | | - | Para. 4.3.9 | | |
| 21 | Oversize Pin Exclusion | Para. 9.29 & Para. 4.3.10 of this spec. | | | - | ESCC 3401 Para. 9.29 | | |
| 22 | Probe Damage | Para. 9.30 & Para. 4.3.11 of this spec. | Contact Separation Force | Para. 4.3.9 of this spec. | - | Para. 4.3.9 | | |
| 23 | Solderability | Para. 9.31 & Para. 4.3.12 of this spec. | | | | ESCC 3401 Para. 9.31 | | |

NOTES

1. The tests in this table refer to either Chart IV or V and shall be used as applicable.