



**DIODES, MICROWAVE, SILICON,
PIN, FAST SWITCHING,
BASED ON TYPES ML4611, ML4612,
ML4614 AND ML4615
ESCC Detail Specification No. 5513/010**

**ISSUE 1
October 2002**



	ESCC Detail Specification		PAGE ii ISSUE 1
--	---------------------------	--	--------------------

LEGAL DISCLAIMER AND COPYRIGHT

European Space Agency, Copyright © 2002. All rights reserved.

The European Space Agency disclaims any liability or responsibility, to any person or entity, with respect to any loss or damage caused, or alleged to be caused, directly or indirectly by the use and application of this ESCC publication.

This publication, without the prior permission of the European Space Agency and provided that it is not used for a commercial purpose, may be:

- copied in whole in any medium without alteration or modification.
- copied in part, in any medium, provided that the ESCC document identification, comprising the ESCC symbol, document number and document issue, is removed.



europaean space agency
agence spatiale européenne

Pages 1 to 38

DIODES, MICROWAVE, SILICON,
PIN, FAST SWITCHING,
BASED ON TYPES ML4611, ML4612,
ML4614 AND ML4615
ESA/SCC Detail Specification No. 5513/010



space components
coordination group

Issue/Rev.	Date	Approved by	
		SCCG Chairman	ESA Director General or his Deputy
Issue 1	June 1993		
Revision 'A'	February 2002		

**SCC**

ESA/SCC Detail Specification

No. 5513/010

PAGE 3

ISSUE 1

TABLE OF CONTENTS

	<u>Page</u>
1. <u>GENERAL</u>	5
1.1 Scope	5
1.2 Type Variants	5
1.3 Maximum Ratings	5
1.4 Parameter Derating Information	5
1.5 Physical Dimensions	5
1.6 Functional Diagram	5
1.7 Handling Precautions	5
2. <u>APPLICABLE DOCUMENTS</u>	5
3. <u>TERMS, DEFINITIONS, ABBREVIATIONS, SYMBOLS AND UNITS</u>	5
4. <u>REQUIREMENTS</u>	26
4.1 General	26
4.2 Deviations from Generic Specification	26
4.2.1 Deviations from Special In-process Controls	26
4.2.2 Deviations from Final Production Tests	26
4.2.3 Deviations from Burn-in and Electrical Measurements	26
4.2.4 Deviations from Qualification Tests	26
4.2.5 Deviations from Lot Acceptance Tests	26
4.3 Mechanical and Environmental Requirements	27
4.3.1 Dimension Check	27
4.3.2 Weight	27
4.3.3 Terminal Strength	27
4.4 Materials and Finishes	28
4.4.1 Case	28
4.4.2 Lead Materials and Finish	28
4.5 Marking	29
4.5.1 General	29
4.5.2 Cathode Identification	29
4.5.3 The SCC Component Number	29
4.5.4 Traceability Information	29
4.6 Electrical Measurements	29
4.6.1 Electrical Measurements at Room Temperature	29
4.6.2 Electrical Measurements at High and Low Temperatures	29
4.6.3 Circuits for Electrical Measurements	29
4.7 Burn-in Tests	30
4.7.1 Parameter Drift Values	30
4.7.2 Conditions for High Temperature Reverse Bias Burn-in	30
4.7.3 Conditions for Power Burn-in	30
4.7.4 Electrical Circuits for High Temperature Reverse Bias and Power Burn-in	30
4.8 Environmental and Endurance Tests	35
4.8.1 Electrical Measurements on Completion of Environmental Tests	35
4.8.2 Electrical Measurements at Intermediate Points and on Completion of Endurance Tests	35
4.8.3 Conditions for Operating Life Tests	35
4.8.4 Electrical Circuits for Operating Life Tests	35
4.9 Total Dose Irradiation Testing	35
4.9.1 Application	35
4.9.2 Bias Conditions	35
4.9.3 Electrical Measurements	35
4.10 Special Testing	35

**SCC**ESA/SCC Detail Specification
No. 5513/010

PAGE 4

ISSUE 1

TABLESPage

1(a)	Type Variants	6
1(b)	Maximum Ratings	9
2	Electrical Measurements at Room Temperature - D.C. Parameters	31
	Electrical Measurements at Room Temperature - A.C. Parameters	31
3	Electrical Measurements at High and Low Temperatures	32
4	Parameter Drift Values	32
5(a)	Conditions for High Temperature Reverse Bias Burn-in	33
5(b)	Conditions for Power Burn-in	34
5(c)	Conditions for Operating Life Tests	34
6	Electrical Measurements at Intermediate Points and on Completion of Endurance Testing	36
7	Electrical Measurements During and on Completion of Irradiation Testing	37

FIGURES

1	Parameter Derating Information	11
2	Physical Dimensions	12
3	Functional Diagram	25
4	Circuits for Electrical Measurements	33
5(a)	Electrical Circuit for High Temperature Reverse Bias Burn-in	34
5(b)	Electrical Circuit for Power Burn-in and Operating Life Tests	34
6	Bias Conditions for Irradiation Testing	36

APPENDICES (Applicable to specific Manufacturers only)

'A'	Agreed deviations for M/A-Com Ltd. (G.B.)	38
-----	---	----

 SCC	ESA/SCC Detail Specification No. 5513/010	PAGE 5 ISSUE 1
---	--	-------------------

1. GENERAL

1.1 SCOPE

This specification details the ratings, physical and electrical characteristics, test and inspection data for a Diode, Microwave, Silicon, PIN, Fast Switching, based on Types ML4611, ML4612, ML4614 and ML4615. It shall be read in conjunction with ESA/SCC Generic Specification No. 5010, the requirements of which are supplemented herein.

1.2 TYPE VARIANTS

Variants of the basic diodes specified herein, which are also covered by this specification are given in Table 1(a).

1.3 MAXIMUM RATINGS

The maximum ratings, which shall not be exceeded at any time during use or storage, applicable to the diodes specified herein, are as scheduled in Table 1(b).

1.4 PARAMETER DERATING INFORMATION

The derating information applicable to the diodes specified herein is shown in Figure 1.

1.5 PHYSICAL DIMENSIONS

The physical dimensions of the diodes specified herein are shown in Figure 2.

1.6 FUNCTIONAL DIAGRAM

The functional diagram, showing lead identification, of the diodes specified herein, is shown in Figure 3.

1.7 HANDLING PRECAUTIONS

These devices are susceptible to damage by electrostatic discharge. Therefore, suitable precautions shall be employed for protection during all phases of manufacture, testing, packaging, shipment and any handling.

These components are Categorised as Class 2 with a Minimum Critical Path Failure Voltage of 2600V.

2. APPLICABLE DOCUMENTS

The following documents form part of this specification and shall be read in conjunction with it:-

- (a) ESA/SCC Generic Specification No. 5010 for Discrete Microwave Semiconductor Components.
- (b) MIL-STD-750, Test Methods and Procedures for Semiconductor Devices.

3. TERMS, DEFINITIONS, ABBREVIATIONS, SYMBOLS AND UNITS

For the purpose of this specification, the terms, definitions, abbreviations, symbols and units specified in ESA/SCC Basic Specification No. 21300 shall apply.

**TABLE 1(a) - TYPE VARIANTS**

(1) VARIANT	(2) BASED ON TYPE	(3) FIGURE	(4) TOTAL CAPACITANCE C_T (pF)		(5) JUNCTION CAPACITANCE C_J (pF) (Typical)	(6) BODY-LID AND LEAD MATERIAL AND FINISH
			MIN	MAX		
01	ML4611 - 30	2(a)	0.25	0.35	0.10	A7-D2
02	ML4611 - 31	2(b)	0.25	0.35	0.10	A7-D2
03	ML4611 - 32	2(c)	0.36	0.46	0.10	A7-D2
04	ML4611 - 34	2(d)	0.45	0.55	0.10	A7-D2
05	ML4611 - 36	2(e)	0.25	0.35	0.10	A7-D2
06	ML4611 - 43	2(f)	0.85	0.95	0.10	A7-D2
07	ML4611 - 56	2(g)	0.58	0.68	0.10	A7-D2
08	ML4611 - 91	2(h)	0.36	0.46	0.10	A7-D2
09	ML4611 - 92	2(i)	0.36	0.46	0.10	A7-D2
10	ML4611 - 94	2(j)	0.23	0.33	0.10	A7-D2
11	ML4611 - 95	2(k)	0.23	0.33	0.10	A7-D2
12	ML4611 - 96	2(l)	0.23	0.33	0.10	A7-D2
13	ML4611 - 97	2(m)	0.23	0.33	0.10	A7-D2
14	ML4611 - 101	2(n)	0.55	0.65	0.10	A7-D2
15	ML4611 - 103	2(o)	0.36	0.46	0.10	A7-D2
16	ML4611 - 118	2(p)	0.30	0.40	0.10	A7
17	ML4611 - 120	2(q)	0.21	0.31	0.10	D2
18	ML4611 - 128	2(r)	0.31	0.41	0.10	A7-D2
19	ML4611 - 138	2(s)	0.26	0.36	0.10	A7
20	ML4611 - 148	2(t)	0.34	0.44	0.10	A7
21	ML4611 - 255	2(u)	0.35	0.45	0.10	A7
22	ML4611 - 275	2(v)	0.43	0.53	0.10	A7
23	ML4611 - 276	2(w)	0.21	0.31	0.10	D2
24	ML4611 - 54	2(x)	0.10	0.35	0.10	C4
25	ML4611 - 186	2(y)	0.20	0.30	0.10	D2
26	ML4612 - 30	2(a)	0.30	0.50	0.20	A7-D2
27	ML4612 - 31	2(b)	0.30	0.50	0.20	A7-D2
28	ML4612 - 32	2(c)	0.41	0.61	0.20	A7-D2
29	ML4612 - 34	2(d)	0.50	0.70	0.20	A7-D2
30	ML4612 - 36	2(e)	0.30	0.50	0.20	A7-D2
31	ML4612 - 43	2(f)	0.90	1.10	0.20	A7-D2
32	ML4612 - 56	2(g)	0.63	0.83	0.20	A7-D2
33	ML4612 - 91	2(h)	0.41	0.61	0.20	A7-D2
34	ML4612 - 92	2(i)	0.41	0.61	0.20	A7-D2
35	ML4612 - 94	2(j)	0.28	0.48	0.20	A7-D2
36	ML4612 - 95	2(k)	0.28	0.48	0.20	A7-D2

**ESCC**

ESA/SCC Detail Specification

No. 5513/010

PAGE 7

ISSUE 1

TABLE 1(a) - TYPE VARIANTS (CONT'D)

(1) VARIANT	(2) BASED ON TYPE	(3) FIGURE	(4) TOTAL CAPACITANCE C_T (pF)		(5) JUNCTION CAPACITANCE C_J (pF) (Typical)	(6) BODY-LID AND LEAD MATERIAL AND FINISH
			MIN	MAX		
37	ML4612 - 96	2(l)	0.28	0.48	0.20	A7-D2
38	ML4612 - 97	2(m)	0.28	0.48	0.20	A7-D2
39	ML4612 - 101	2(n)	0.60	0.80	0.20	A7-D2
40	ML4612 - 103	2(o)	0.41	0.61	0.20	A7-D2
41	ML4612 - 118	2(p)	0.35	0.55	0.20	A7
42	ML4612 - 120	2(q)	0.26	0.46	0.20	D2
43	ML4612 - 128	2(r)	0.36	0.56	0.20	A7-D2
44	ML4612 - 138	2(s)	0.31	0.51	0.20	A7
45	ML4612 - 148	2(t)	0.39	0.59	0.20	A7
46	ML4612 - 255	2(u)	0.40	0.60	0.20	A7
47	ML4612 - 275	2(v)	0.48	0.68	0.20	A7
48	ML4612 - 276	2(w)	0.26	0.46	0.20	D2
49	ML4612 - 54	2(x)	0.15	0.25	0.20	C4
50	ML4612 - 186	2(y)	0.25	0.45	0.20	D2
51	ML4614 - 30	2(a)	0.25	0.35	0.10	A7-D2
52	ML4614 - 31	2(b)	0.25	0.35	0.10	A7-D2
53	ML4614 - 32	2(c)	0.36	0.46	0.10	A7-D2
54	ML4614 - 34	2(d)	0.45	0.55	0.10	A7-D2
55	ML4614 - 36	2(e)	0.25	0.35	0.10	A7-D2
56	ML4614 - 43	2(f)	0.85	0.95	0.10	A7-D2
57	ML4614 - 56	2(g)	0.58	0.68	0.10	A7-D2
58	ML4614 - 91	2(h)	0.36	0.46	0.10	A7-D2
59	ML4614 - 92	2(i)	0.36	0.46	0.10	A7-D2
60	ML4614 - 94	2(j)	0.23	0.33	0.10	A7-D2
61	ML4614 - 95	2(k)	0.23	0.33	0.10	A7-D2
62	ML4614 - 96	2(l)	0.23	0.33	0.10	A7-D2
63	ML4614 - 97	2(m)	0.23	0.33	0.10	A7-D2
64	ML4614 - 101	2(n)	0.55	0.65	0.10	A7-D2
65	ML4614 - 103	2(o)	0.36	0.46	0.10	A7-D2
66	ML4614 - 118	2(p)	0.30	0.40	0.10	A7
67	ML4614 - 120	2(q)	0.21	0.31	0.10	D2
68	ML4614 - 128	2(r)	0.31	0.41	0.10	A7-D2
69	ML4614 - 138	2(s)	0.26	0.36	0.10	A7
70	ML4614 - 148	2(t)	0.34	0.44	0.10	A7
71	ML4614 - 255	2(u)	0.35	0.45	0.10	A7
72	ML4614 - 275	2(v)	0.43	0.53	0.10	A7



TABLE 1(a) - TYPE VARIANTS (CONT'D)

(1) VARIANT	(2) BASED ON TYPE	(3) FIGURE	(4) TOTAL CAPACITANCE C _T (pF)		(5) JUNCTION CAPACITANCE C _J (pF) (Typical)	(6) BODY-LID AND LEAD MATERIAL AND FINISH
			MIN	MAX		
73	ML4614 - 276	2(w)	0.21	0.31	0.10	D2
74	ML4614 - 54	2(x)	0.10	0.20	0.10	C4
75	ML4614 - 186	2(y)	0.20	0.30	0.10	D2
76	ML4615 - 30	2(a)	0.30	0.50	0.20	A7-D2
77	ML4615 - 31	2(b)	0.30	0.50	0.20	A7-D2
78	ML4615 - 32	2(c)	0.41	0.61	0.20	A7-D2
79	ML4615 - 34	2(d)	0.50	0.70	0.20	A7-D2
80	ML4615 - 36	2(e)	0.30	0.50	0.20	A7-D2
81	ML4615 - 43	2(f)	0.90	1.10	0.20	A7-D2
82	ML4615 - 56	2(g)	0.63	0.83	0.20	A7-D2
83	ML4615 - 91	2(h)	0.41	0.61	0.20	A7-D2
84	ML4615 - 92	2(i)	0.41	0.61	0.20	A7-D2
85	ML4615 - 94	2(j)	0.28	0.48	0.20	A7-D2
86	ML4615 - 95	2(k)	0.28	0.48	0.20	A7-D2
87	ML4615 - 96	2(l)	0.28	0.48	0.20	A7-D2
88	ML4615 - 97	2(m)	0.28	0.48	0.20	A7-D2
89	ML4615 - 101	2(n)	0.60	0.80	0.20	A7-D2
90	ML4615 - 103	2(o)	0.41	0.61	0.20	A7-D2
91	ML4615 - 118	2(p)	0.35	0.55	0.20	A7
92	ML4615 - 120	2(q)	0.26	0.46	0.20	D2
93	ML4615 - 128	2(r)	0.36	0.56	0.20	A7-D2
94	ML4615 - 138	2(s)	0.31	0.51	0.20	A7
95	ML4615 - 148	2(t)	0.39	0.59	0.20	A7
96	ML4615 - 255	2(u)	0.40	0.60	0.20	A7
97	ML4615 - 275	2(v)	0.48	0.68	0.20	A7
98	ML4615 - 276	2(w)	0.26	0.46	0.20	D2
99	ML4615 - 186	2(y)	0.25	0.45	0.20	D2

**TABLE 1(b) - MAXIMUM RATINGS**

No.	CHARACTERISTIC	SYMBOL	MAXIMUM RATINGS	UNIT	REMARKS
1	D.C. Reverse Voltage Variants 01 to 50 Variants 51 to 99	V_R	- 40 - 70	V	Note 1
2	D.C. Forward Current (Continuous) Variants 24, 49 and 74 All other Variants	I_F	100 150	mA	Note 1 Note 2
3	R.F. Power Dissipation Variants 01 to 23 Variant 24 Variant 25 Variants 26 to 48 Variant 49 Variant 50 Variants 51 to 73 Variant 74 Variant 75 Variants 76 to 98 Variant 99	P_{tot}	1.7 0.2 0.5 2.0 0.2 0.5 2.0 0.2 0.5 2.5 0.5	W	Note 1
4	Operating Temperature Range Variants 24, 49 and 74 All other Variants	T_{op}	- 65 to + 125 - 65 to + 150	°C	T_{case}
5	Storage Temperature Range Variants 24, 49 and 74 All other Variants	T_{stg}	- 65 to + 125 - 65 to + 150	°C	
6	Soldering Temperature	T_{sol}	+ 230	°C	Note 3

NOTES

1. At $T_{case} = +25^{\circ}\text{C}$. For derating at $T_{case} > +25^{\circ}\text{C}$, see Figure 1.
2. At $T_{case} = +100^{\circ}\text{C}$. For derating at $T_{case} > +100^{\circ}\text{C}$, see Figure 1.
3. Duration 5 seconds maximum (at a distance of not less than 1.5mm from the body for Variants 23, 24, 25, 48, 49, 50, 73, 74, 75, 98 and 99) and the same termination shall not be resoldered until 3 minutes have elapsed.



FIGURE 1 - PARAMETER DERATING INFORMATION

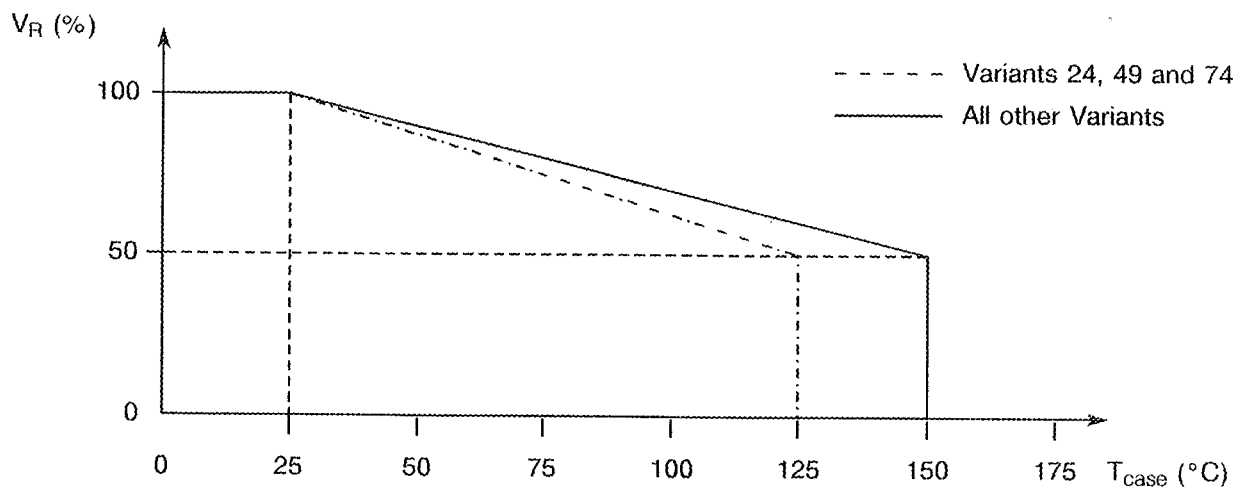

Reverse Voltage versus Temperature

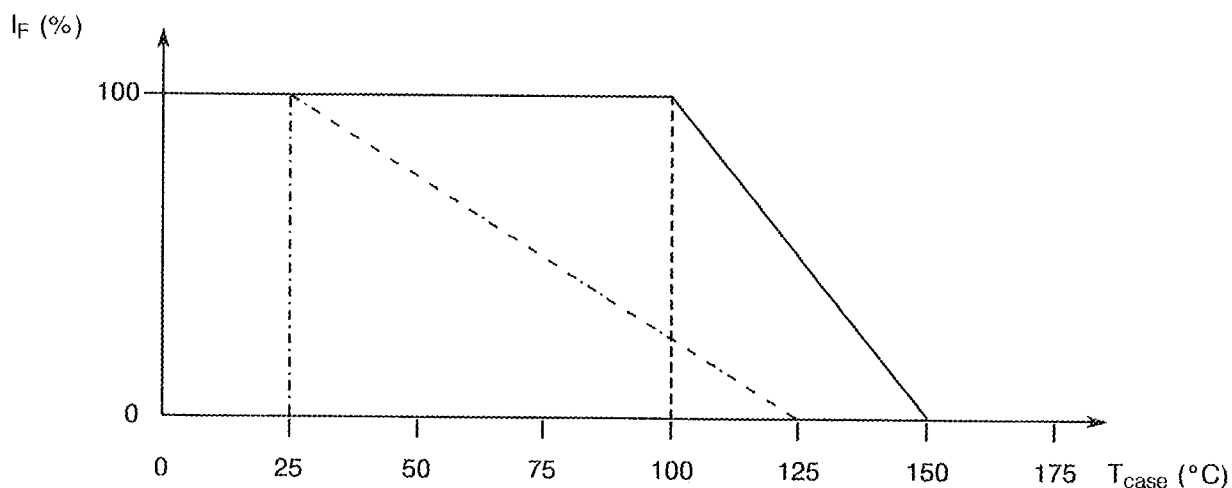

Forward Current versus Temperature

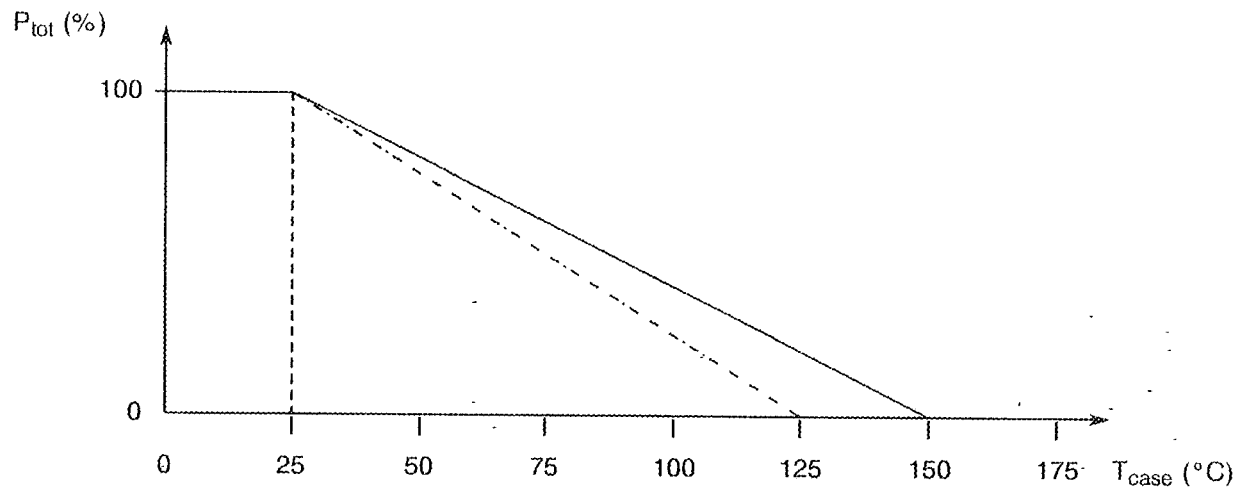

Power Dissipation versus Temperature



FIGURE 2 - PHYSICAL DIMENSIONS

FIGURE 2(a) - VARIANTS 01, 26, 51, 76

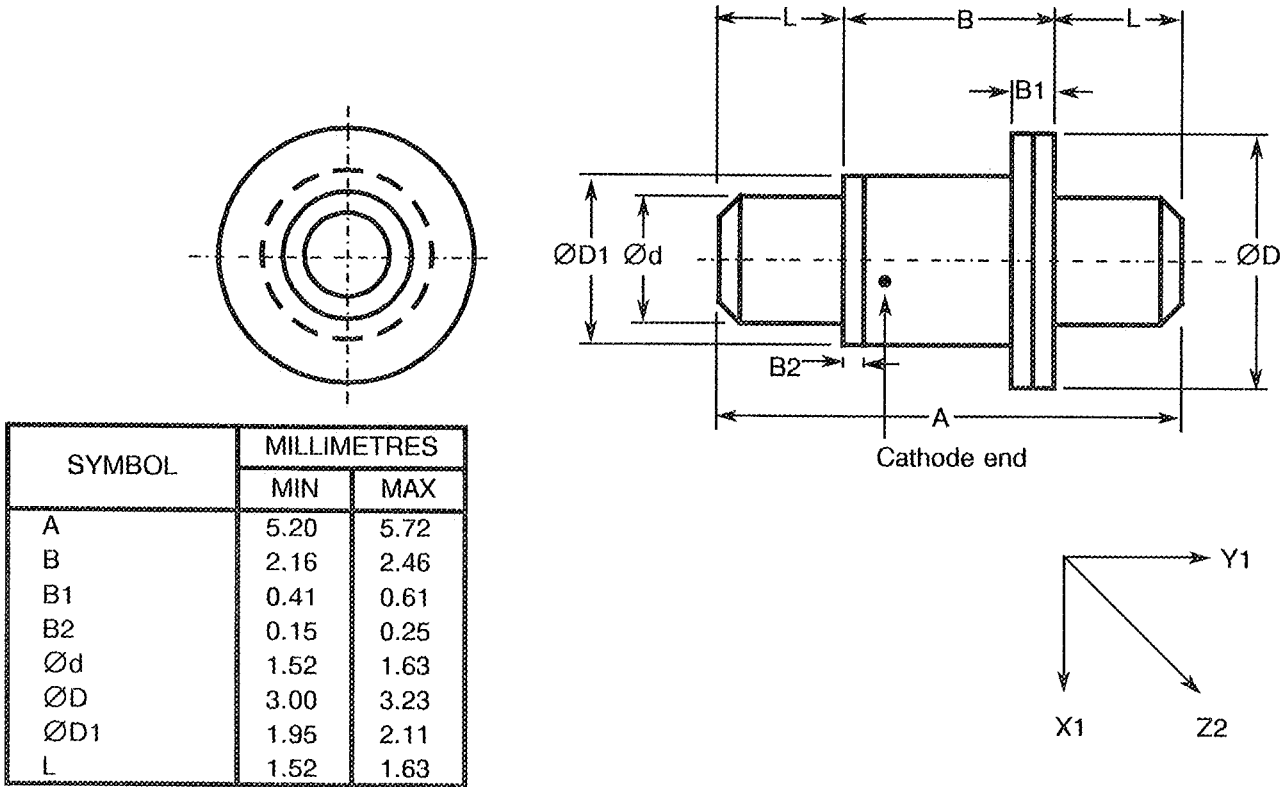

FIGURE 2(b) - VARIANTS 02, 27, 52, 77

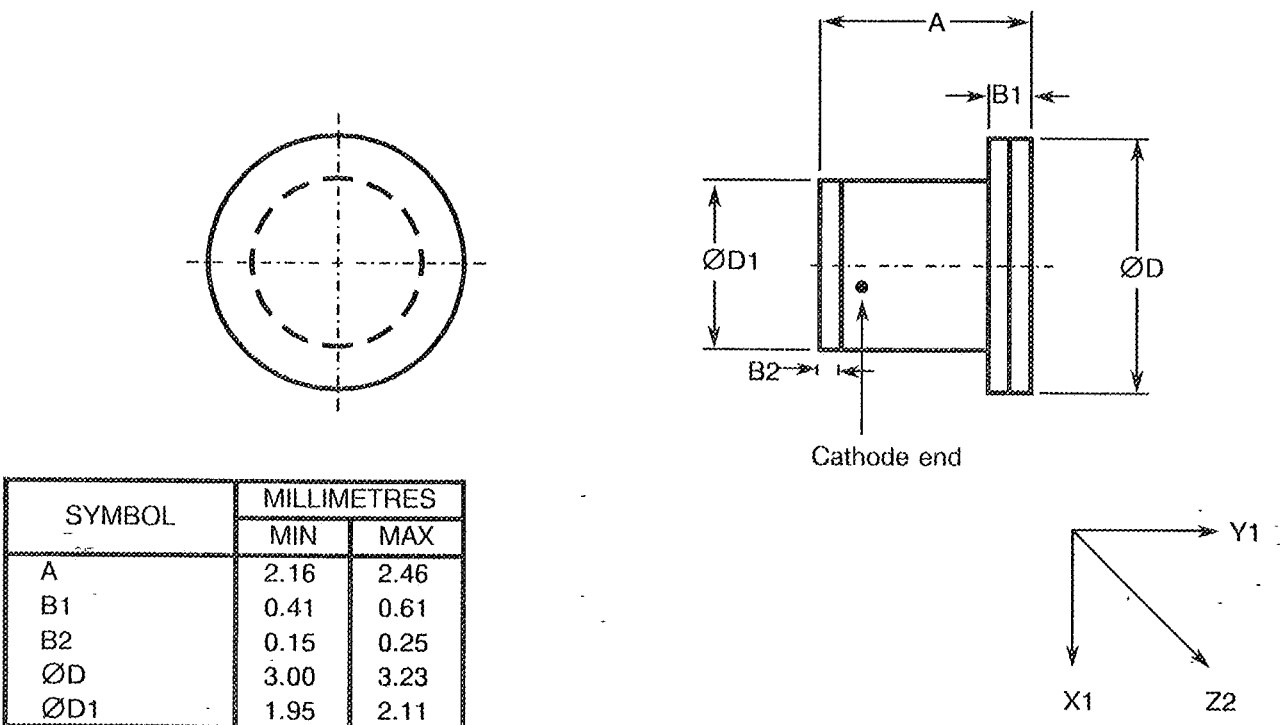
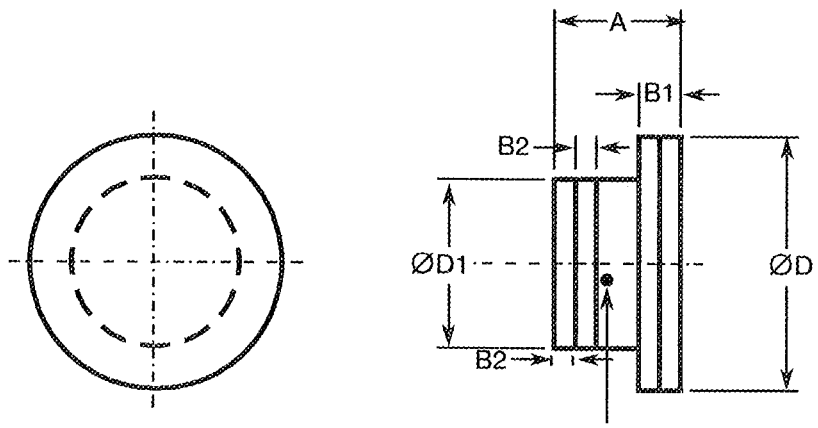
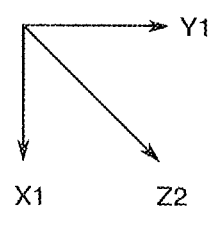
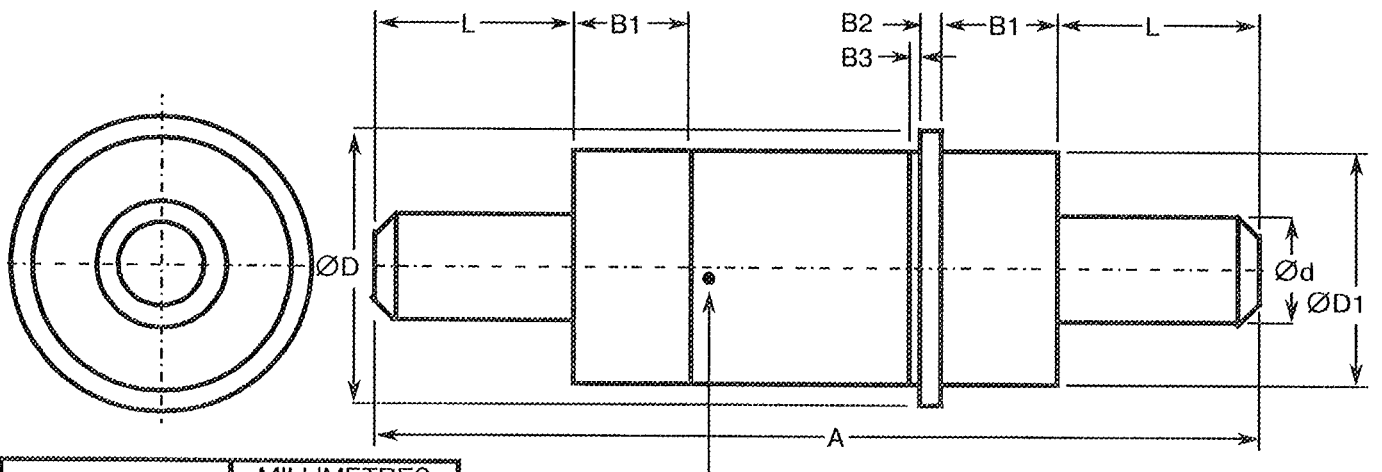

FIGURE 2 - PHYSICAL DIMENSIONS (CONTINUED)
FIGURE 2(c) - VARIANTS 03, 28, 53, 78

SYMBOL	MILLIMETRES	
	MIN	MAX
A	1.37	1.68
B1	0.41	0.61
B2	0.15	0.20
ØD	3.00	3.23
ØD1	1.95	2.11

FIGURE 2(d) - VARIANTS 04, 29, 54, 79

SYMBOL	MILLIMETRES	
	MIN	MAX
A	19.45	20.12
B1	2.54	-
B2	0.53	0.83
B3	0.19	0.41
Ød	2.33	2.44
ØD	-	6.10
ØD1	5.20	5.46
L	4.57	4.83

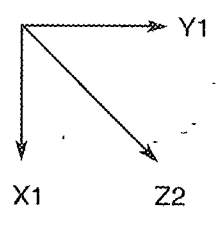
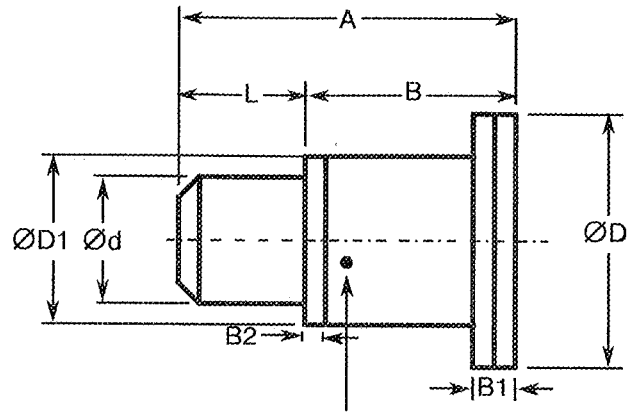
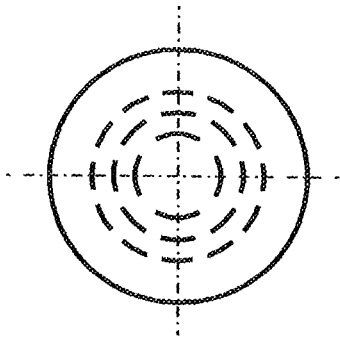



FIGURE 2 - PHYSICAL DIMENSIONS (CONTINUED)

FIGURE 2(e) - VARIANTS 05, 30, 55, 80



Cathode end

SYMBOL	MILLIMETRES	
	MIN	MAX
A	3.60	4.18
B	2.16	2.46
B1	0.41	0.61
B2	0.15	0.25
Ød	1.52	1.63
ØD	3.00	3.23
ØD1	1.95	2.11
L	1.52	1.63

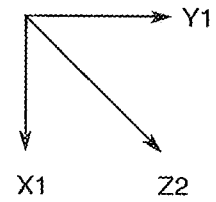
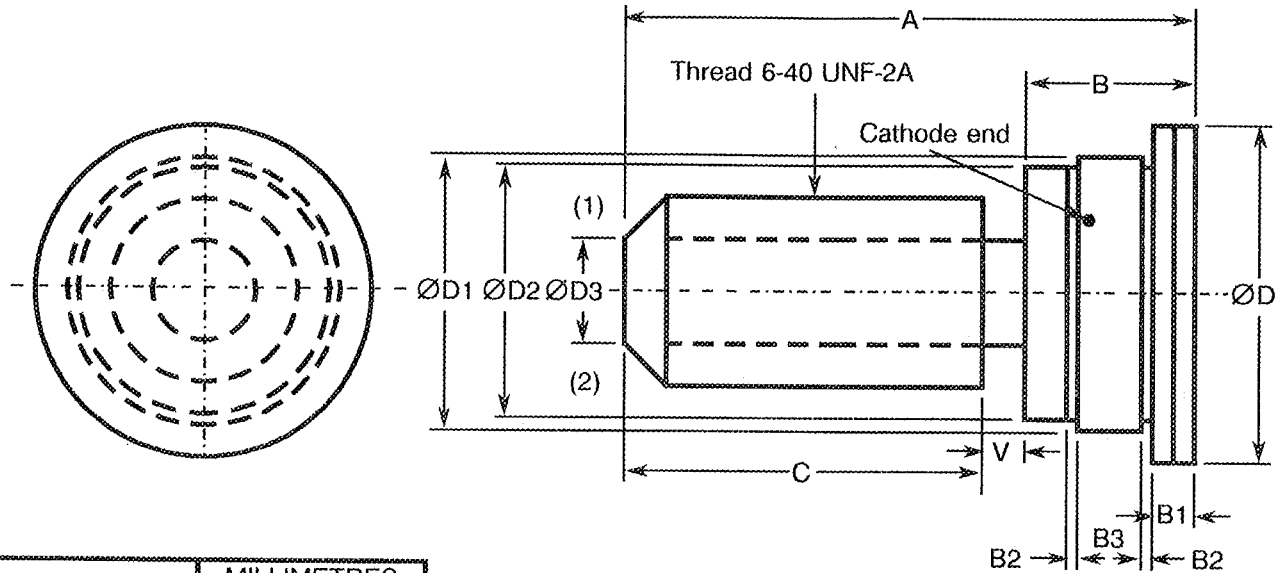



FIGURE 2 - PHYSICAL DIMENSIONS (CONTINUED)

FIGURE 2(f) - VARIANTS 06, 31, 56, 81



SYMBOL	MILLIMETRES	
	MIN	MAX
A	11.18	11.68
B	3.02	3.66
B1	0.64	0.89
B2	0.18	0.23
B3	1.17	1.27
C	6.50	7.90
ØD	6.48	6.73
ØD1	5.20	5.50
ØD2	4.80	5.20
ØD3	2.00	2.70
V	0.76	1.02

NOTES

1. Spline socket to fit spline key 1.78mm deep.
2. 0.51mm x 45°.



FIGURE 2 - PHYSICAL DIMENSIONS (CONTINUED)

FIGURE 2(g) - VARIANTS 07, 32, 57, 82

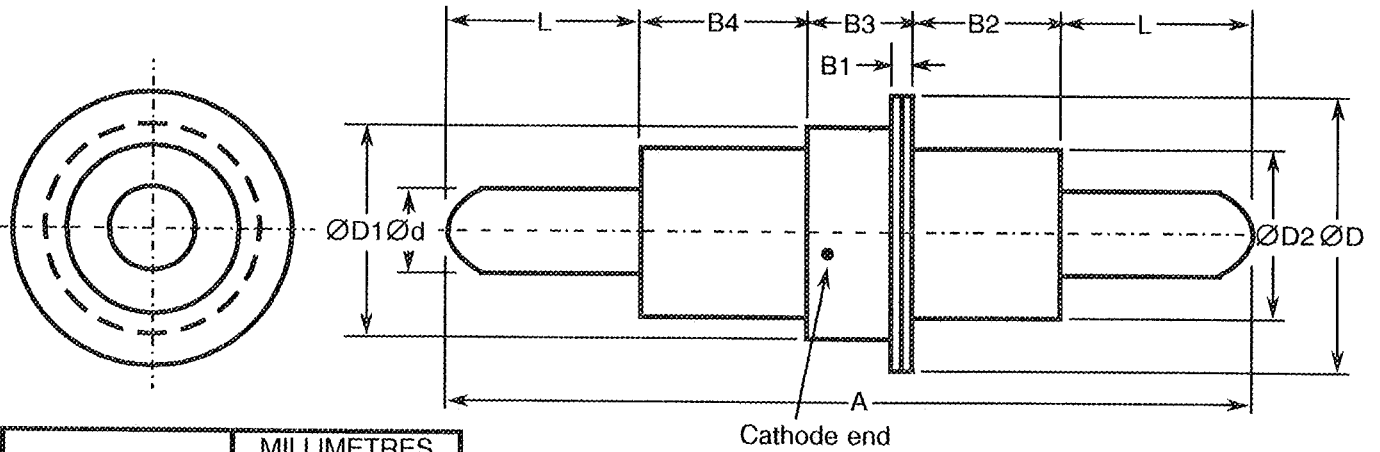

SYMBOL	MILLIMETRES	
	MIN	MAX
A	19.46	20.12
B1	-	0.76
B2	3.00	3.60
B3	2.41	2.67
B4	3.68	3.94
Ød	2.33	2.39
ØD	-	6.10
ØD1	4.72	4.83
ØD2	3.81	4.19
L	4.57	4.83

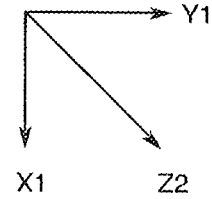
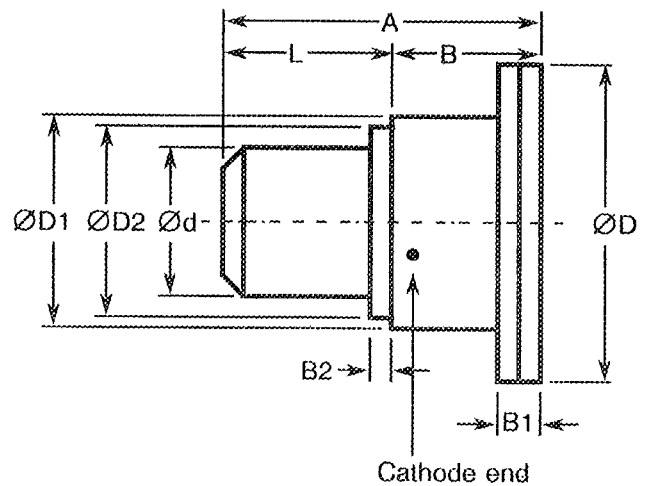
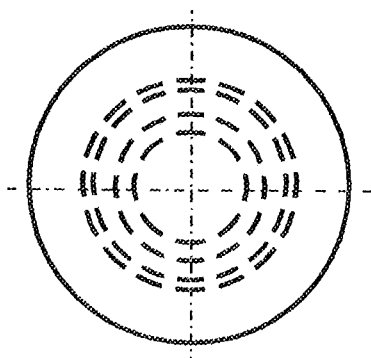

FIGURE 2(h) - VARIANTS 08, 33, 58, 83



SYMBOL	MILLIMETRES	
	MIN	MAX
A	2.92	3.28
B	1.40	1.65
B1	0.41	0.61
B2	0.15	0.20
Ød	1.52	1.63
ØD	3.00	3.23
ØD1	1.95	2.11
ØD2	1.85	2.03
L	1.52	1.63

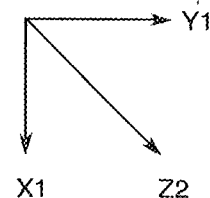
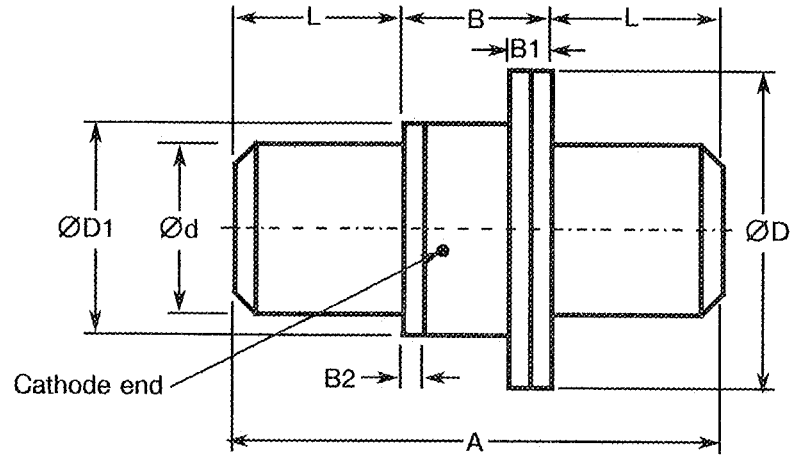
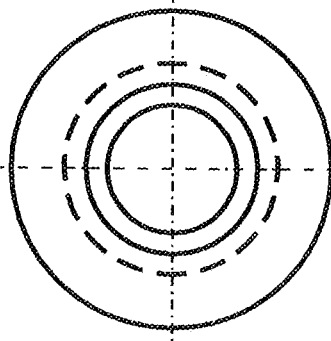



FIGURE 2 - PHYSICAL DIMENSIONS (CONTINUED)

FIGURE 2(i) - VARIANTS 09, 34, 59, 84



SYMBOL	MILLIMETRES	
	MIN	MAX
A	4.42	4.93
B	1.40	1.65
B1	0.41	0.61
B2	0.15	0.20
Ød	1.52	1.63
ØD	3.00	3.23
ØD1	1.95	2.11
L	1.52	1.63

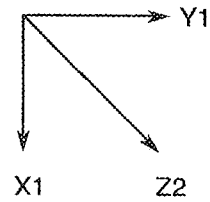
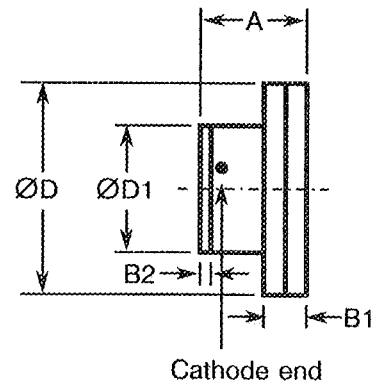
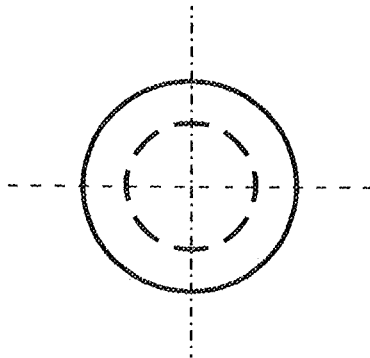

FIGURE 2(ii) - VARIANTS 10, 35, 60, 85



SYMBOL	MILLIMETRES	
	MIN	MAX
A	1.02	1.27
B1	-	0.38
B2	0.10	0.25
ØD	1.98	2.18
ØD1	1.19	1.35

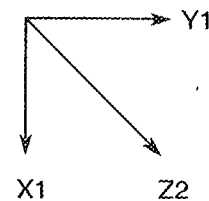
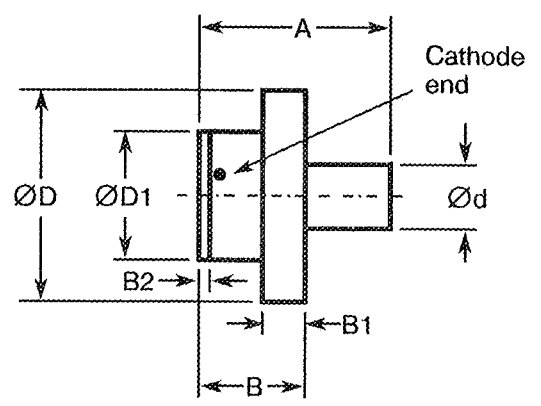
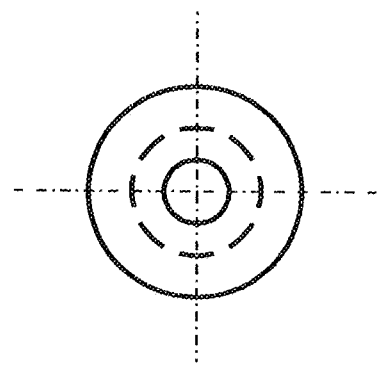



FIGURE 2 - PHYSICAL DIMENSIONS (CONTINUED)

FIGURE 2(k) - VARIANTS 11, 36, 61, 86



SYMBOL	MILLIMETRES	
	MIN	MAX
A	1.78	2.03
B	1.02	1.27
B1	-	0.38
B2	0.10	0.25
Ød	0.61	0.66
ØD	1.98	2.18
ØD1	1.19	1.35

FIGURE 2(l) - VARIANTS 12, 37, 62, 87

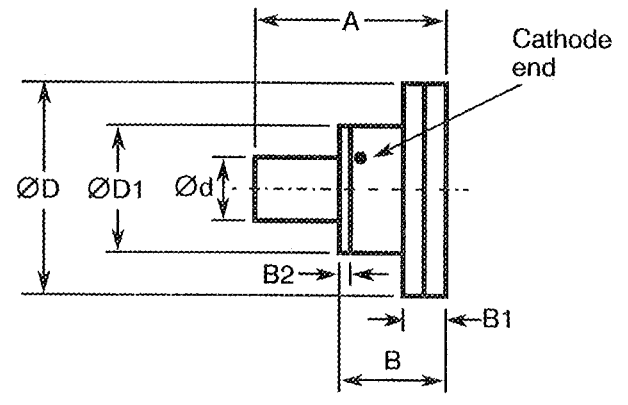
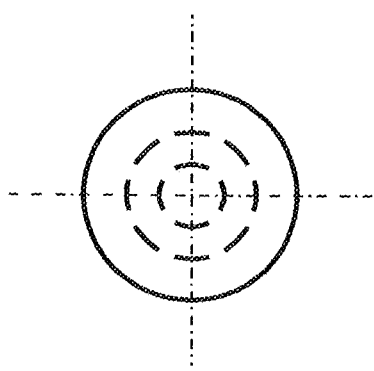

SYMBOL	MILLIMETRES	
	MIN	MAX
A	1.78	2.03
B	1.02	1.27
B1	-	0.38
B2	0.10	0.25
Ød	0.61	0.66
ØD	1.98	2.18
ØD1	1.19	1.35

FIGURE 2 - PHYSICAL DIMENSIONS (CONTINUED)

FIGURE 2(m) - VARIANTS 13, 38, 63, 88

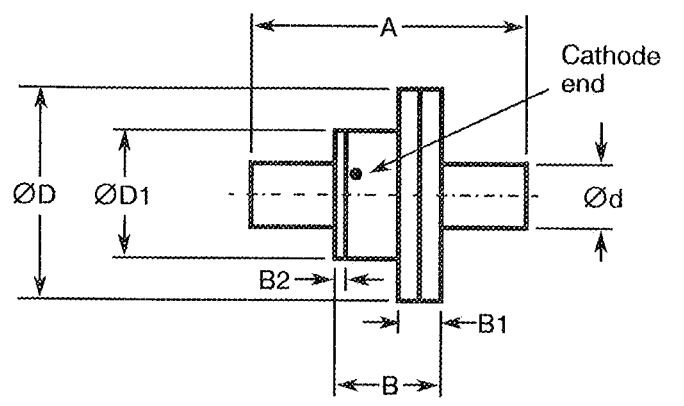
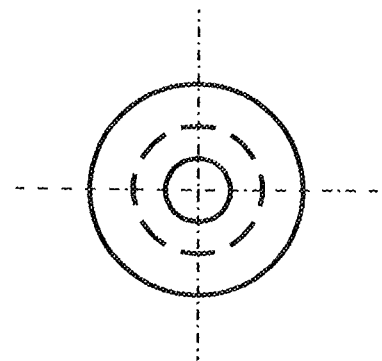

SYMBOL	MILLIMETRES	
	MIN	MAX
A	2.54	2.79
B	1.02	1.27
B1	-	0.38
B2	0.10	0.25
Ød	0.61	0.66
ØD	1.98	2.18
ØD1	1.19	1.35

FIGURE 2(n) - VARIANTS 14, 39, 64, 89

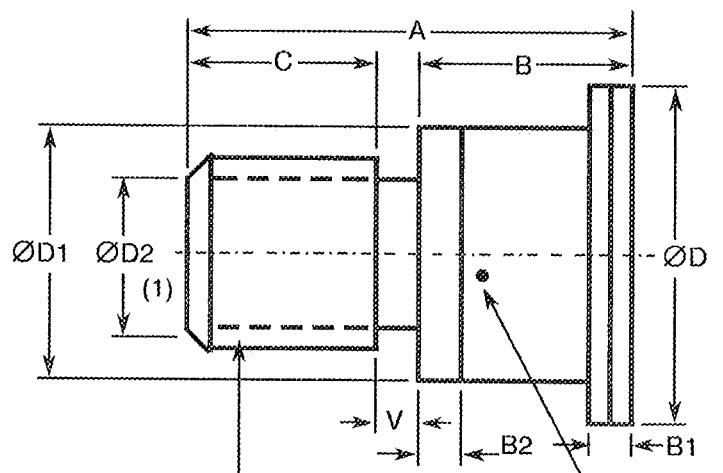
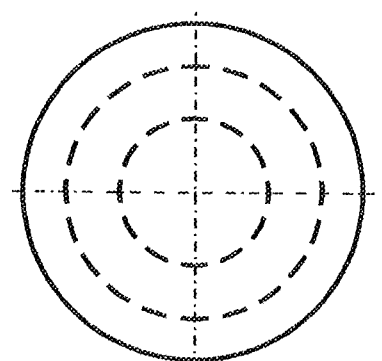

SYMBOL	MILLIMETRES	
	MIN	MAX
A	5.34	5.74
B	2.52	2.72
B1	0.61	0.81
B2	0.65	0.85
C	1.68	2.58
ØD	4.03	4.09
ØD1	3.05	3.25
ØD2	1.60	2.00
V	0.64	0.94

NOTES

1. 6 spline socket, 1.39mm deep.



FIGURE 2 - PHYSICAL DIMENSIONS (CONTINUED)

FIGURE 2(o) - VARIANTS 15, 40, 65, 90

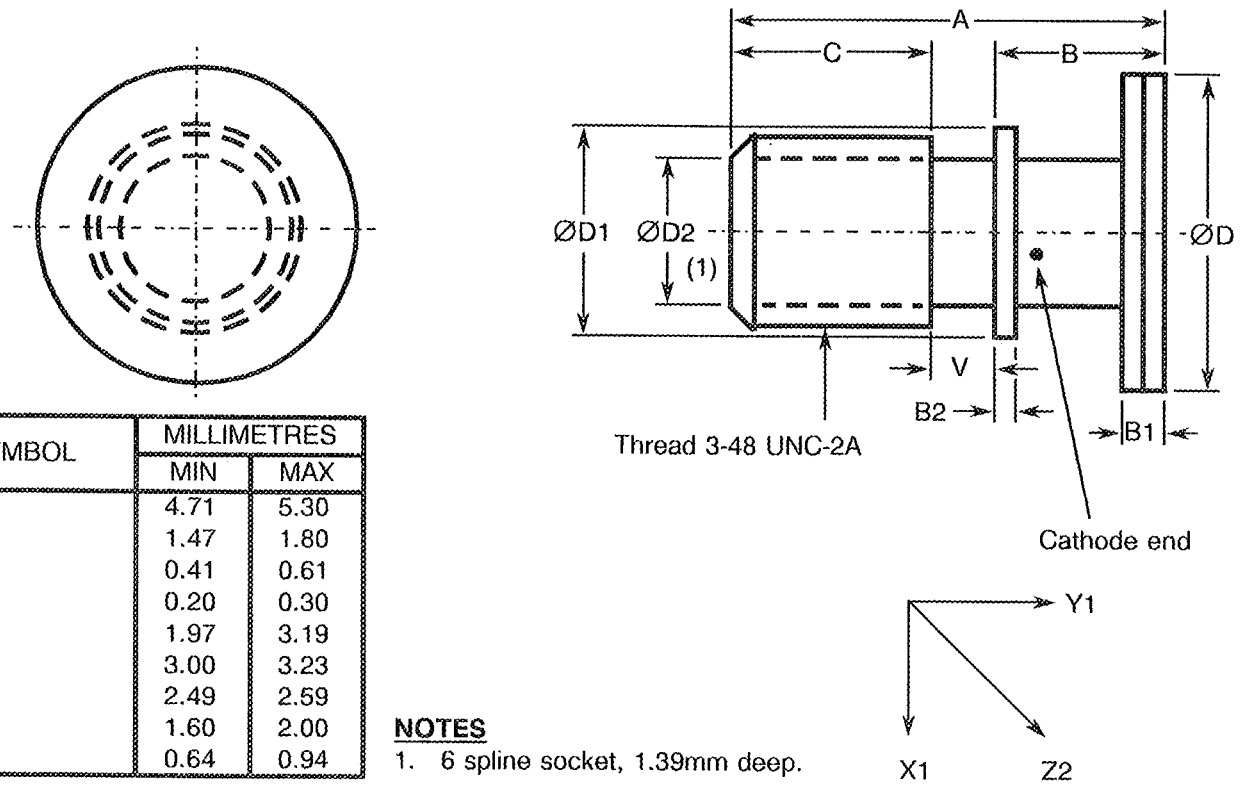

SYMBOL	MILLIMETRES	
	MIN	MAX
A	4.71	5.30
B	1.47	1.80
B1	0.41	0.61
B2	0.20	0.30
C	1.97	3.19
ØD	3.00	3.23
ØD1	2.49	2.59
ØD2	1.60	2.00
V	0.64	0.94

- NOTES**
1. 6 spline socket, 1.39mm deep.

FIGURE 2(p) - VARIANTS 16, 41, 66, 91

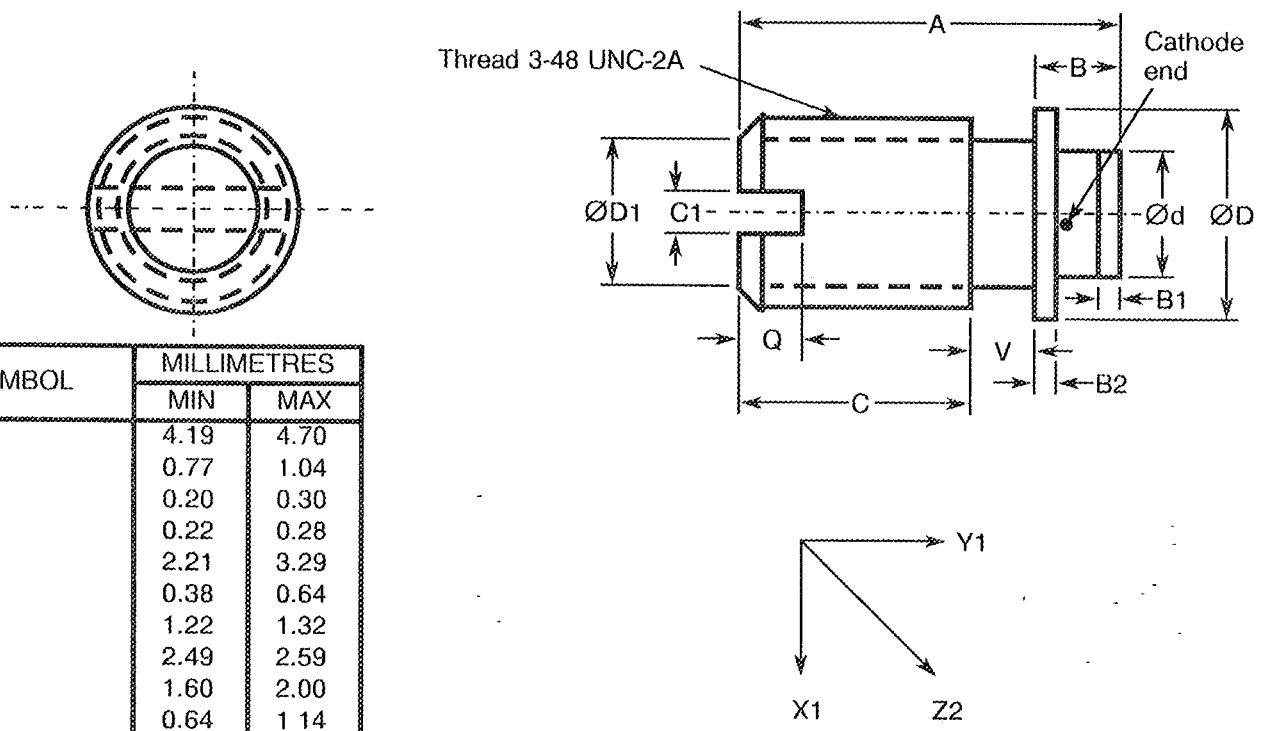

SYMBOL	MILLIMETRES	
	MIN	MAX
A	4.19	4.70
B	0.77	1.04
B1	0.20	0.30
B2	0.22	0.28
C	2.21	3.29
C1	0.38	0.64
Ød	1.22	1.32
ØD	2.49	2.59
ØD1	1.60	2.00
Q	0.64	1.14
V	0.64	0.94



FIGURE 2 - PHYSICAL DIMENSIONS (CONTINUED)

FIGURE 2(q) - VARIANTS 17, 42, 67, 92

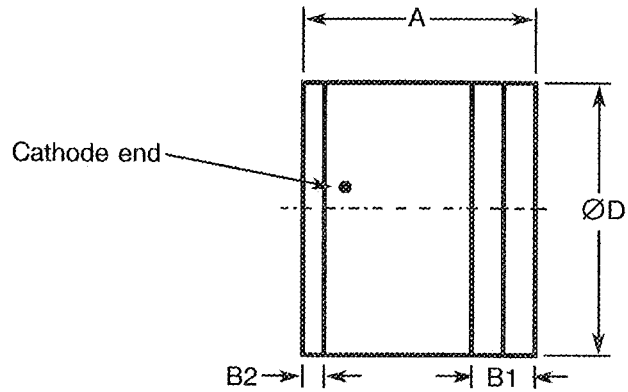
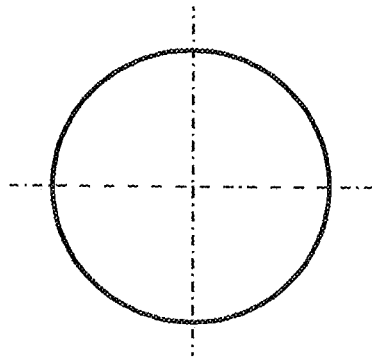

SYMBOL	MILLIMETRES	
	MIN	MAX
A	1.02	1.27
B1	0.23	0.33
B2	0.10	0.15
ØD	1.29	1.40

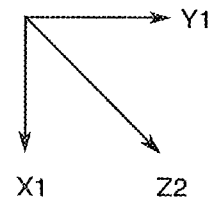
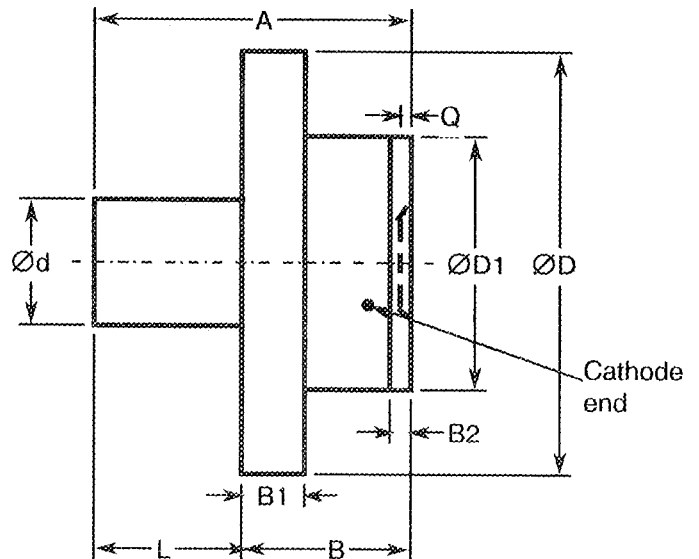
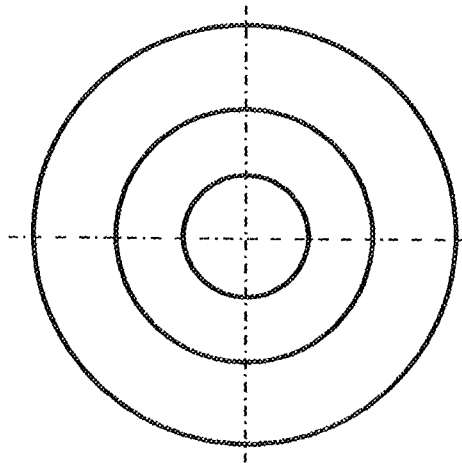

FIGURE 2(r) - VARIANTS 18, 43, 68, 93



SYMBOL	MILLIMETRES	
	MIN	MAX
A	1.384	1.715
B	0.749	0.826
B1	0.025	0.038
B2	0.05	0.18
Ød	0.56	0.71
ØD	1.96	2.11
ØD1	1.19	1.35
Q	0.038	0.076
L	0.558	0.996

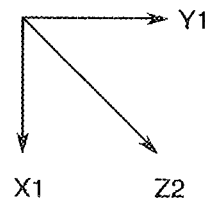



FIGURE 2 - PHYSICAL DIMENSIONS (CONTINUED)

FIGURE 2(s) - VARIANTS 19, 44, 69, 94

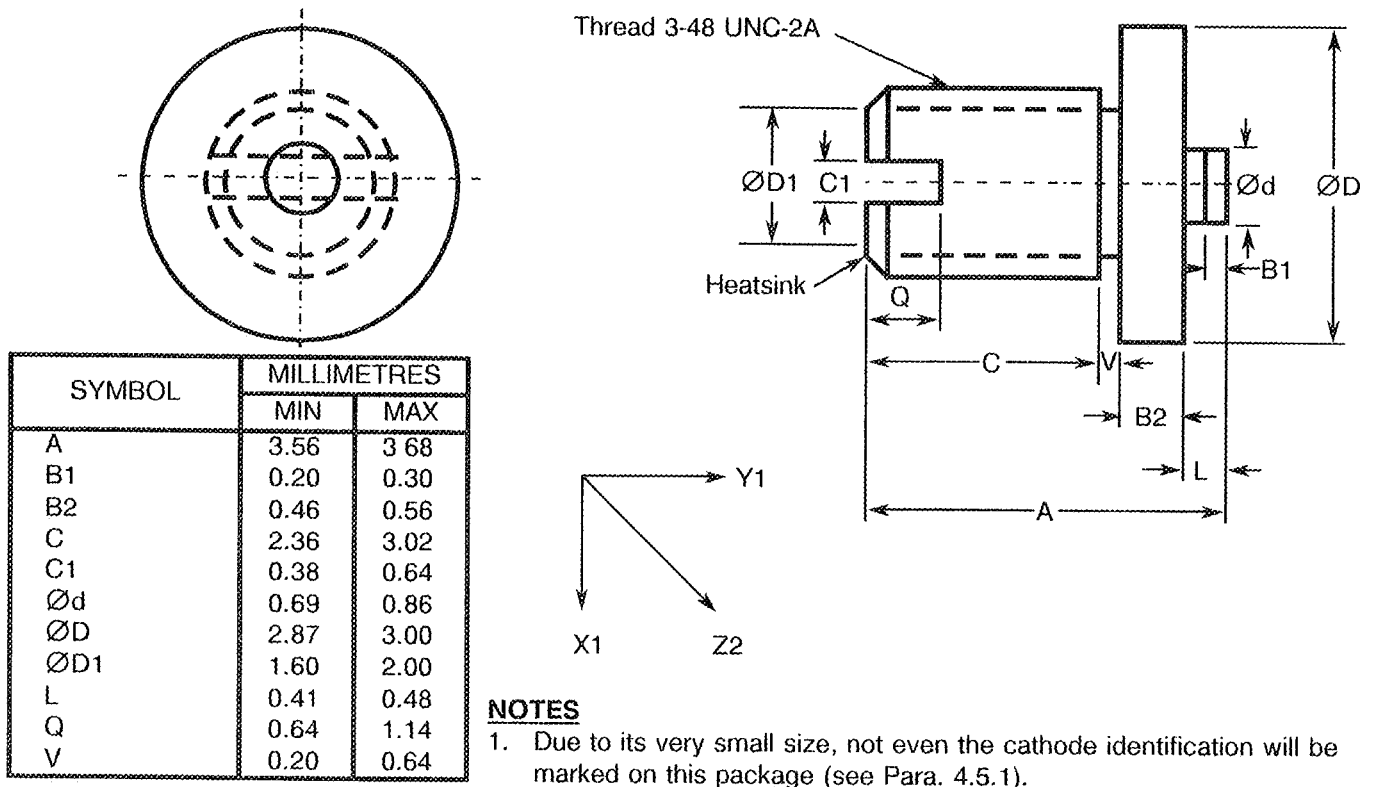

FIGURE 2(t) - VARIANTS 20, 45, 70, 95

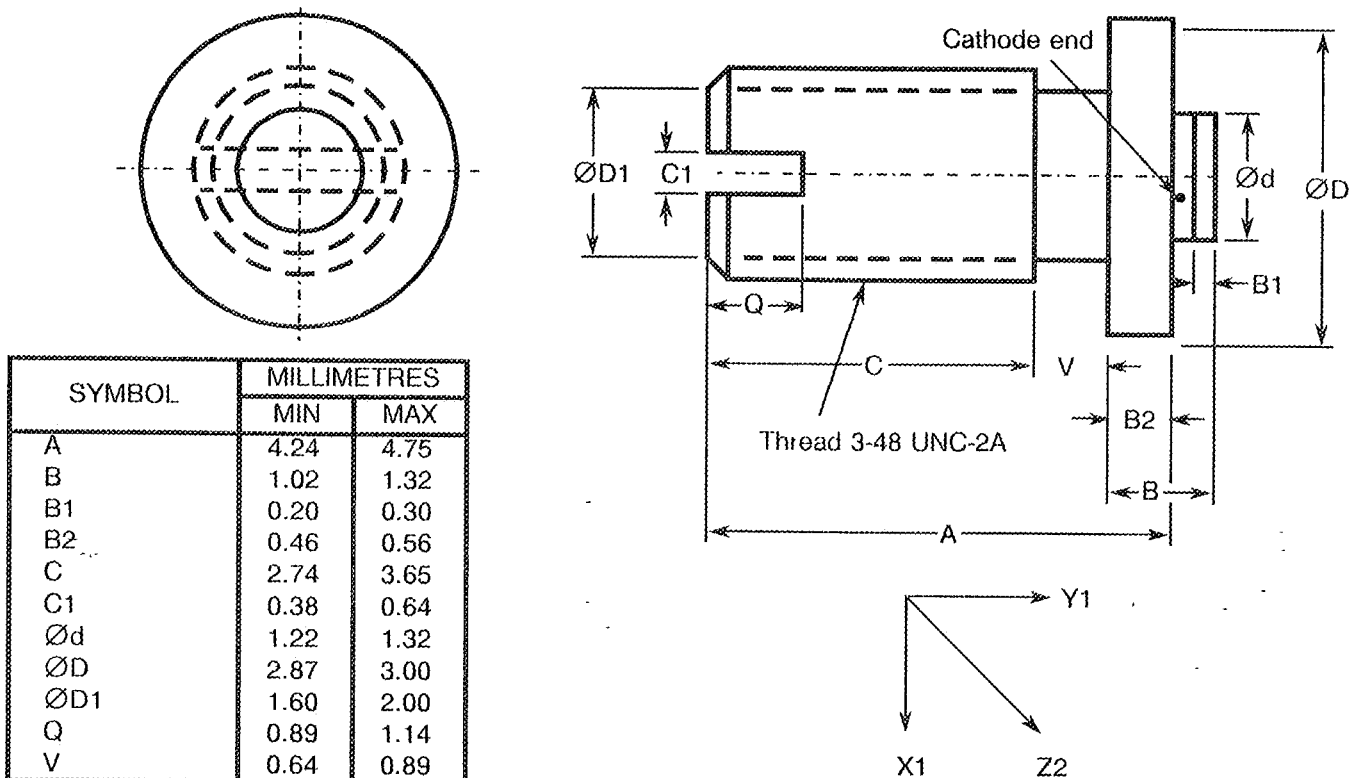



FIGURE 2 - PHYSICAL DIMENSIONS (CONTINUED)

FIGURE 2(u) - VARIANTS 21, 46, 71, 96

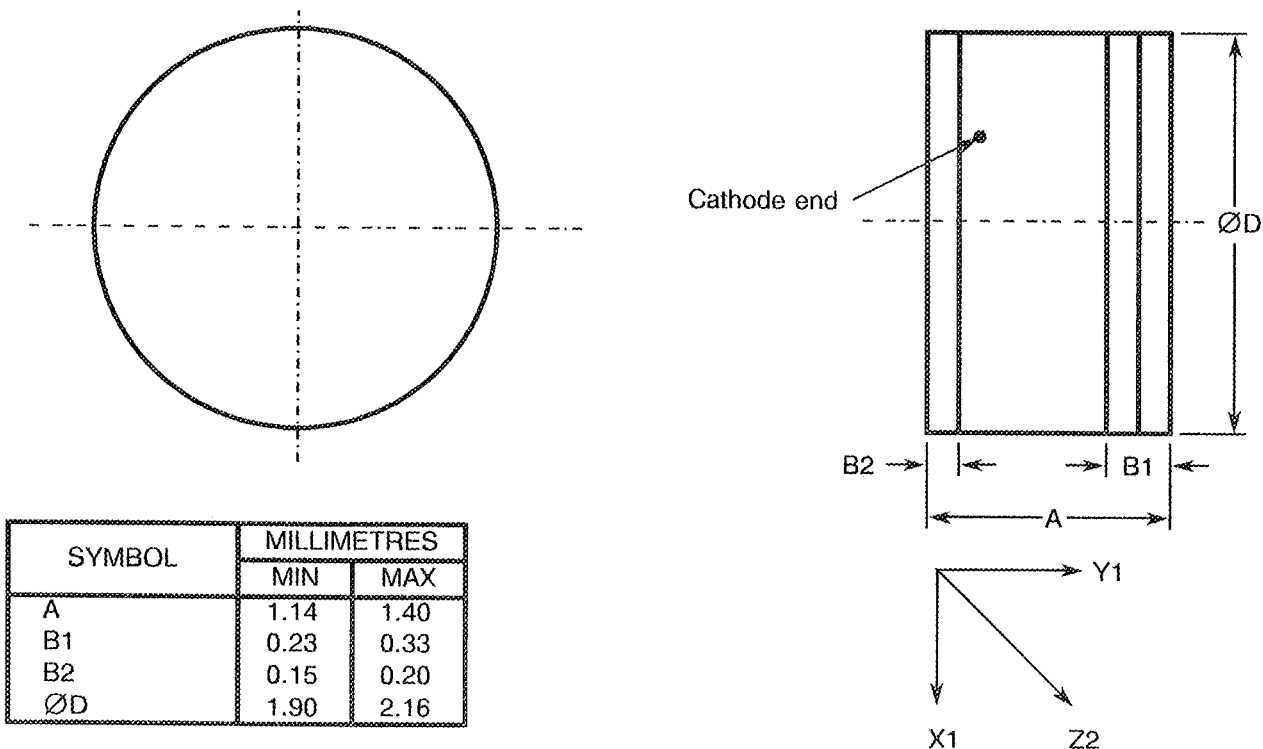

FIGURE 2(v) - VARIANTS 22, 47, 72, 97

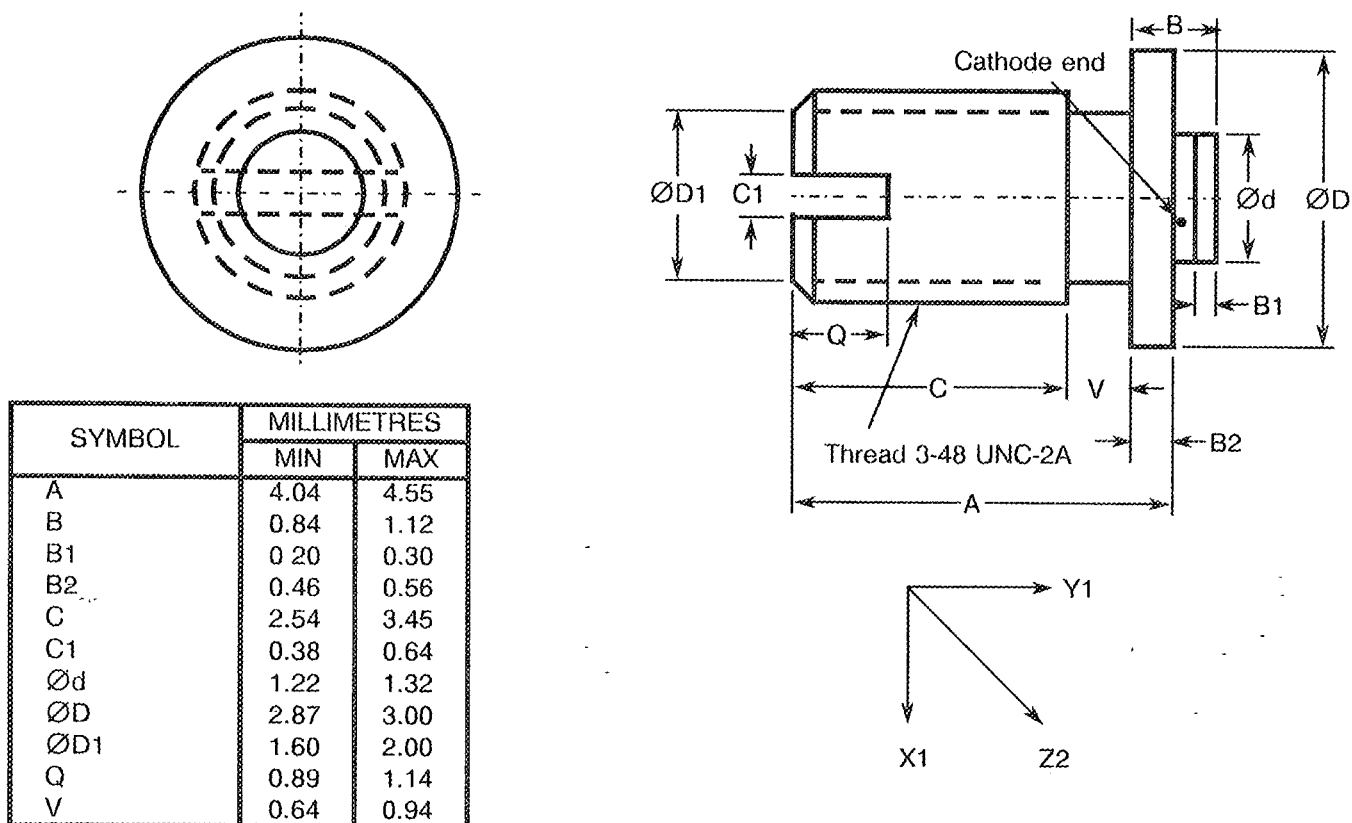
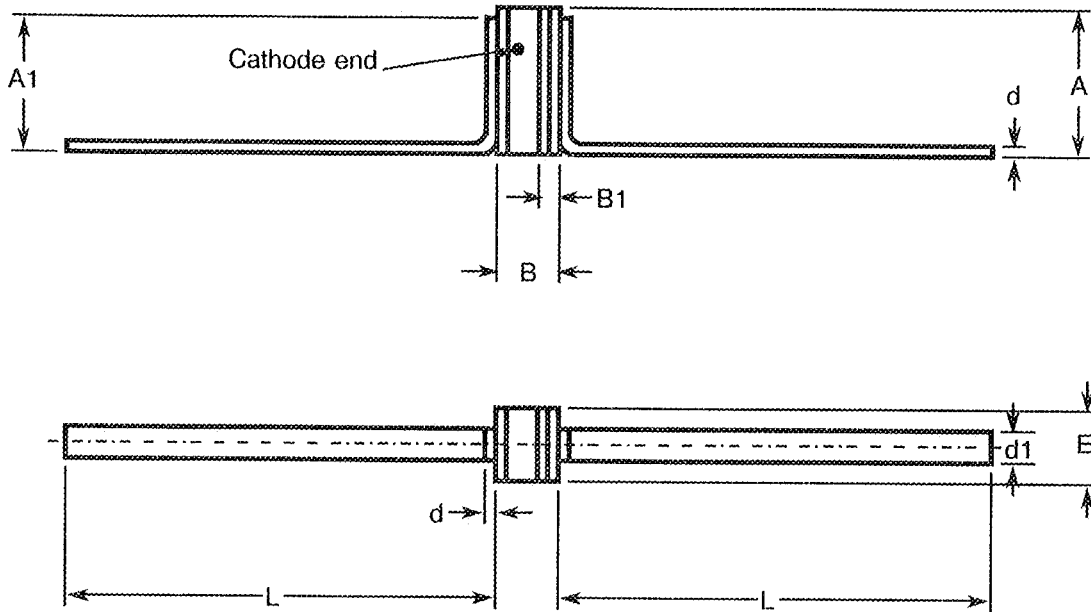



FIGURE 2 - PHYSICAL DIMENSIONS (CONTINUED)

FIGURE 2(w) - VARIANTS 23, 48, 73, 98



SYMBOL	MILLIMETRES	
	MIN	MAX
A	1.35	2.54
A1	-	2.46
B	1.02	1.27
B1	-	0.38
d	0.07	0.15
d1	0.38	0.64
E	1.29	1.40
L	6.10	12.40

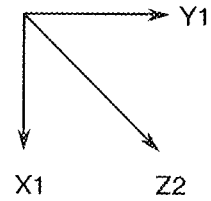
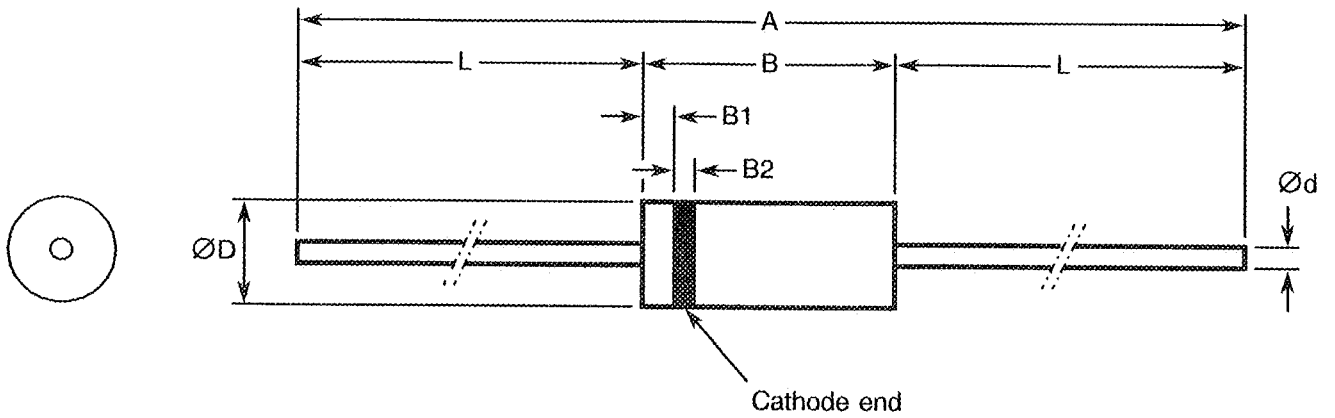



FIGURE 2 - PHYSICAL DIMENSIONS (CONTINUED)

FIGURE 2(x) - VARIANTS 24, 49, 74



SYMBOL	MILLIMETRES	
	MIN	MAX
A	54.48	80.39
B	3.68	4.19
B1	0.10	1.04
B2	0.30	0.80
Ød	0.35	0.41
ØD	1.73	1.91
L	25.40	38.10

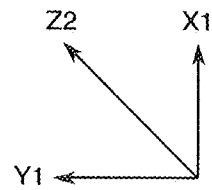
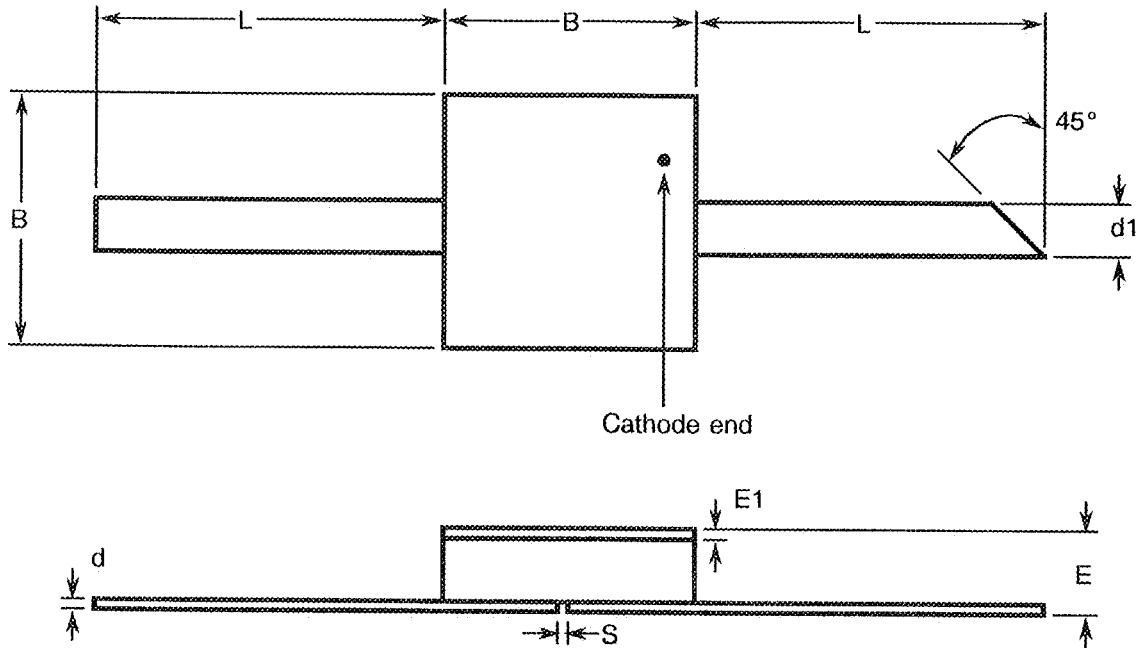



FIGURE 2 - PHYSICAL DIMENSIONS (CONTINUED)

FIGURE 2(y) - VARIANTS 25, 50, 75, 99



SYMBOL	MILLIMETRES	
	MIN	MAX
B	2.39	2.62
d	0.07	0.15
d1	0.48	0.56
E	0.79	1.12
E1	0.10	0.18
L	3.30	5.84
S	0.10	-

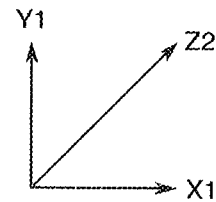
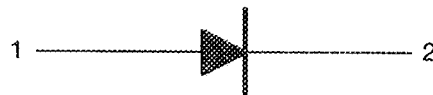

FIGURE 3 - FUNCTIONAL DIAGRAM



- 1. Anode
- 2. Cathode

NOTES

1. The cathode end shall be marked with a black dot or band. The marking will not be on the cathode connection but adjacent to it.
2. The heatsink end shall be the same as the cathode end.



4. REQUIREMENTS

4.1 GENERAL

The complete requirements for procurement of the diodes specified herein shall be as stated in this specification and ESA/SCC Generic Specification No. 5010 for Discrete Microwave Semiconductor Components. Deviations from the Generic Specification applicable to this specification only, are listed in Para. 4.2.

Deviations from the applicable Generic Specification and this Detail Specification, formally agreed with specific Manufacturers on the basis that the alternative requirements are equivalent to the ESA/SCC requirements and do not affect the components' reliability, are listed in the appendices attached to this specification.

4.2 DEVIATIONS FROM GENERIC SPECIFICATION

4.2.1 Deviations from Special In-process Controls

- (a) Para. 5.2.3, Total Dose Irradiation Testing: Shall be performed during qualification and extension of qualification.
- (b) Para. 5.2.3, Total Dose Irradiation Testing: Shall be performed during procurement on a lot acceptance basis at the total dose irradiation level specified in the purchase order.
- (c) Para. 5.3, Wafer Lot Acceptance: Shall be performed as an S.E.M. Inspection only.

4.2.2 Deviations from Final Production Tests (Chart II(b))

- (a) Para. 6.3, Pre-burn-in: Shall be performed in accordance with Para. 9.21(a).
- (b) Para. 9.1, Internal Visual Inspection: For Variants 19, 44, 69 and 94, the 3 devices prepared for the Bond Strength Test shall be exempt from the maximum height of bond wire above die requirement.
- (c) Para. 9.2.1, Bond Strength: For Variants 19, 44, 69 and 94, 3 devices shall have bonds which are long enough to permit this test to be performed. This test shall not be performed for Variants 24, 49 and 74.
- (d) Para. 9.2.2, Die Shear: Shall not be performed for Variants 19, 24, 44, 49, 69, 74 and 94 and no additional thermal tests shall be performed to replace this test.

4.2.3 Deviations from Burn-in and Electrical Measurements (Chart III(a))

- (a) Para. 9.2, High Temperature Reverse Bias Burn-in: Shall be performed at 50% of rated V_R .

4.2.4 Deviations from Qualification Tests (Chart IV)

- (a) Para. 9.2.3, Bond Strength: Shall not be performed for Variants 19, 24, 44, 49, 69, 74 and 94.
- (b) Para. 9.2.4, Die Shear: Shall not be performed for Variants 19, 24, 44, 49, 69, 74 and 94 for which thermal resistance measurements shall be made in accordance with Table 2 of this specification.
- (c) Para. 9.23, Special Testing: Shall not be performed.

4.2.5 Deviations from Lot Acceptance Tests (Chart V)

- (a) Para. 9.23, Special Testing: Shall not be performed.



4.3 MECHANICAL AND ENVIRONMENTAL REQUIREMENTS

4.3.1 Dimension Check

The dimensions of the diodes specified herein shall be checked. They shall conform to those shown in Figure 2.

4.3.2 Weight

The maximum weight of the diodes specified herein shall be:

Variant No.	Weight (g)
01, 26, 51, 76	0.12
02, 27, 52, 77	0.06
03, 28, 53, 78	0.08
04, 29, 54, 79	2.14
05, 30, 55, 80	0.10
06, 31, 56, 81	1.10
07, 32, 57, 82	1.80
08, 33, 58, 83	0.11
09, 34, 59, 84	0.13
10, 35, 60, 85	0.013
11, 36, 61, 86	0.015
12, 37, 62, 87	0.015

Variant No.	Weight (g)
13, 38, 63, 88	0.022
14, 39, 64, 89	0.24
15, 40, 65, 90	0.14
16, 41, 66, 91	0.14
17, 42, 67, 92	0.014
18, 43, 68, 93	0.12
19, 44, 69, 94	0.15
20, 45, 70, 95	0.15
21, 46, 71, 96	0.08
22, 47, 72, 97	0.15
23, 48, 73, 98	0.025
24, 49, 74	0.10
25, 50, 75, 99	0.06

4.3.3 Terminal Strength

The requirements for terminal strength testing are specified in Section 9 of ESA/SCC Generic Specification No. 5010. The test conditions shall be as follows:-

(a) **Condition: 'A' (Tension)**

Variants 23, 48, 73 and 98:

- Force: 1.22N.
- Duration: 5 seconds.

Variants 24, 25, 49, 50, 74, 75 and 99:

- Force: 5.1N.
- Duration: 5 seconds.

(b) **Condition: 'D2' (Stud Torque)**

Variants 06, 31, 56 and 81:

- Torque: 70mNm.
- Duration: 5 seconds.

Variants 14, 15, 39, 40, 64, 65, 89 and 90:

- Torque: 56mNm.
- Duration: 5 seconds.



Variants 16, 17, 19, 20, 22, 41, 42, 44, 45, 47, 66, 67, 69, 70, 72, 94, 91, 92, 95 and 97:

- Torque: 42mNm.
- Duration: 5 seconds.

(c) Condition: Compression

Variants 01, 02, 03, 04, 05, 06, 07, 08, 09, 14, 15, 18, 21, 26, 27, 28, 29, 30, 31, 32, 33, 34, 39, 40, 43, 46, 51, 52, 53, 54, 55, 56, 57, 58, 59, 64, 65, 68, 71, 76, 77, 78, 79, 80, 81, 82, 83, 84, 89, 90, 93 and 96:

- Force: 50N.
- Duration: 5 seconds.

Variants 10, 11, 12, 13, 16, 20, 22, 35, 36, 37, 38, 41, 45, 47, 60, 61, 62, 63, 66, 70, 72, 85, 86, 87, 88, 91, 95 and 97:

- Force: 10N.
- Duration: 5 seconds.

Variants 19, 44, 69 and 94:

- Force: 5N.
- Duration: 5 seconds.

The compression test shall be performed by applying the specified force to the end-cap by means of a suitable weight applied for the specified time. On completion of the test, a visual examination shall be performed to check for damage to the end-cap or the ceramic body.

4.4 MATERIALS AND FINISHES

The materials and finishes shall be as specified herein. Where a definite material is not specified, a material which will enable the diodes specified herein to meet the performance requirements of this specification shall be used. Acceptance or approval of any constituent material shall not guarantee acceptance of the finished product.

4.4.1 Case

The case shall be hermetically sealed and have a ceramic body. The lid shall be welded or preform soldered. For Variants 24, 49 and 74, the case shall be hermetically sealed and have a glass body.

4.4.2 Lead Materials and Finish

- For Variants 01, 02, 03, 04, 05, 06, 07, 08, 09, 10, 11, 12, 13, 14, 15, 18, 26, 27, 28, 29, 30, 31, 32, 33, 34, 35, 36, 37, 38, 39, 40, 43, 51, 52, 53, 54, 55, 56, 57, 58, 59, 60, 61, 62, 63, 64, 65, 68, 76, 77, 78, 79, 80, 81, 82, 83, 84, 85, 86, 87, 88, 89, 90 and 93, the body material shall be Type 'A' with Type '7' finish and the lid material shall be Type 'D' with Type '2' finish, in accordance with the requirements of ESA/SCC Basic Specification No. 23500.
- For Variants 16, 19, 20, 21, 22, 41, 44, 45, 46, 47, 66, 69, 70, 71, 72, 94, 91, 95, 96 and 97, the lead material shall be Type 'A' with Type '7' finish in accordance with the requirements of ESA/SCC Basic Specification No. 23500.
- For Variants 17, 23, 25, 42, 48, 50, 67, 73, 75, 92, 98 and 99, the lead material shall be Type 'D' with Type '2' finish in accordance with the requirements of ESA/SCC Basic Specification No. 23500.
- For Variants 24, 49 and 74, the lead material shall be Type 'C' with Type '4' finish in accordance with the requirements of ESA/SCC Basic Specification No. 23500.



4.5 MARKING

4.5.1 General

The marking of components delivered to this specification shall be in accordance with the requirements of ESA/SCC Basic Specification No. 21700 and the following paragraphs. When the component is too small to accommodate all of the marking specified, as much as space permits shall be marked and the marking information, in full, shall accompany the component in its primary package.

The information to be marked and the order of precedence, shall be as follows:-

- (a) Cathode Identification.
- (b) The SCC Component Number.
- (c) Traceability Information.

4.5.2 Cathode Identification

Cathode identification shall be as shown in Figures 2 and 3 of this specification.

4.5.3 The SCC Component Number

Each component shall bear the SCC Component Number which shall be constituted and marked as follows:

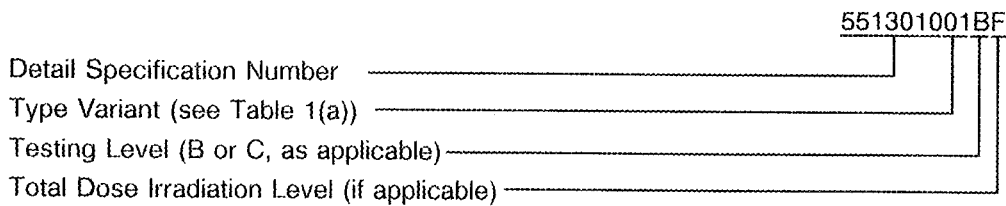

The Total Dose Irradiation Level designation shall be added for those devices for which a sample has been successfully tested to the level in question. For these devices, a code letter shall be added in accordance with the requirements of ESA/SCC Basic Specification No. 22900.

4.5.4 Traceability Information

Each component shall be marked in respect of traceability information as defined in ESA/SCC Basic Specification No. 21700.

4.6 ELECTRICAL MEASUREMENTS

4.6.1 Electrical Measurements at Room Temperature

The parameters to be measured at room temperature are scheduled in Table 2. Unless otherwise specified, the measurements shall be performed at $T_{amb} = +22 \pm 3$ °C.

4.6.2 Electrical Measurements at High and Low Temperatures

The parameters to be measured at high and low temperatures are scheduled in Table 3. Unless otherwise specified, the measurements shall be performed at $T_{amb} = +125(+0-3)$ °C for Variants 24, 49 and 74 and $T_{amb} = +150(+0-3)$ °C for all other Variants.

4.6.3 Circuits for Electrical Measurements

Circuits for use in performing electrical measurements listed in Table 2 of this specification are shown in Figure 4.



4.7 BURN-IN TESTS

Burn-in shall be Category 2 of Chart III(a).

4.7.1 Parameter Drift Values

The parameter drift values applicable to burn-in are specified in Table 4 of this specification. Unless otherwise stated, the measurements shall be performed at $T_{amb} = +22 \pm 3$ °C. The parameter drift values (Δ) applicable to the scheduled parameters shall not be exceeded. In addition to these drift value requirements for a given parameter, the appropriate limit value specified in Table 2 shall not be exceeded.

4.7.2 Conditions for High Temperature Reverse Bias Burn-in

The requirements for the high temperature reverse bias burn-in are specified in Section 7 of ESA/SCC Generic Specification No. 5010. The conditions for high temperature reverse bias burn-in shall be as specified in Table 5(a) of this specification.

4.7.3 Conditions for Power Burn-in

The requirements for power burn-in are specified in Section 7 of ESA/SCC Generic Specification No. 5010. The conditions for power burn-in shall be as specified in Table 5(b) of this specification.

4.7.4 Electrical Circuits for High Temperature Reverse Bias and Power Burn-in

Circuits for use in performing the H.T.R.B and power burn-in tests are shown in Figures 5(a) and 5(b) of this specification.



TABLE 2 - ELECTRICAL MEASUREMENTS AT ROOM TEMPERATURE - D.C. PARAMETERS

No.	CHARACTERISTICS	SYMBOL	MIL-STD-750 TEST METHOD	TEST CONDITIONS	LIMITS		UNIT
					MIN.	MAX.	
1	Reverse Current 1	I_{R1}	4016	Variants 01 to 50: $V_R = -40V$ Variants 51 to 99: $V_R = -70V$	-	10	μA
2	Reverse Current 2	I_{R2}	4016	Variants 01 to 50: $V_R = -20V$ Variants 51 to 99: $V_R = -35V$	-	50	nA
3	Forward Voltage	V_F	4011	$I_F = 100mA$	-	1.5	V
4	Thermal Resistance	$R_{TH(J-C)}$	3101	$I_F = 1.0A$ Note 1 Variants 01 to 23 Variant 24 Variant 25 Variants 26 to 48 Variant 49 Variant 50 Variants 51 to 73 Variant 74 Variant 75 Variants 76 to 98 Variant 99	- - - - - - - - - - - - - - - -	70 500 230 60 500 220 60 500 220 50 210	$^{\circ}C/W$

NOTES

1. Pulsed measurement, pulse width = 4.0 μs , p.r.f. = 1.0kHz.

TABLE 2 - ELECTRICAL MEASUREMENTS AT ROOM TEMPERATURE - A.C. PARAMETERS

No.	CHARACTERISTICS	SYMBOL	MIL-STD-750 TEST METHOD	TEST FIG.	TEST CONDITIONS	LIMITS		UNIT
						MIN.	MAX.	
5	Total Capacitance	C_T	4001	-	$V_R = -10V$ $f = 1.0MHz$	Note 1		pF
6	Minority Carrier Lifetime	τ_L	-	4(a)	$I_F = 10mA$ Variants 01 to 50 Variants 51 to 99	- -	70 200	ns
7	Forward Slope Resistance	R_{FS}	-	4(b)	$I_F = 40mA$ $f_o = 500MHz$ Variants 01 to 25 Variants 26 to 50 Variants 51 to 75 Variants 76 to 99	- - - -	1.5 1.3 1.5 1.3	Ω

NOTES

1. See Column 4 of Table 1(a).

**TABLE 3 - ELECTRICAL MEASUREMENTS AT HIGH AND LOW TEMPERATURES**

No.	CHARACTERISTICS	SYMBOL	SPEC.AND/OR TEST METHOD	TEST CONDITIONS	LIMITS		UNIT
					MIN.	MAX.	
2	Reverse Current 2	I_{R2}	As per Table 2	As per Table 2	-	10	μ A

TABLE 4 - PARAMETER DRIFT VALUES

No.	CHARACTERISTICS	SYMBOL	SPEC.AND/OR TEST METHOD	TEST CONDITIONS	CHANGE LIMITS (Δ)	UNIT
2	Reverse Current 2	I_{R2}	As per Table 2	As per Table 2	± 10 (1) or (2) ± 100 (1)	nA %
3	Forward Voltage	V_F	As per Table 2	As per Table 2	± 100 (1)	mV

NOTES1. $\Delta 1 = \Delta 2$.

2. Whichever is the greater, referred to the initial measurement.



FIGURE 4 - CIRCUITS FOR ELECTRICAL MEASUREMENTS

FIGURE 4(a) - MINORITY CARRIER LIFETIME

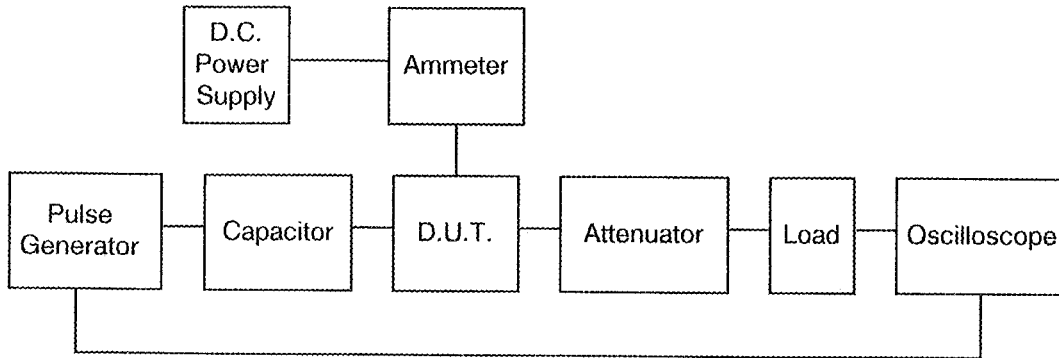

FIGURE 4(b) - FORWARD SLOPE RESISTANCE

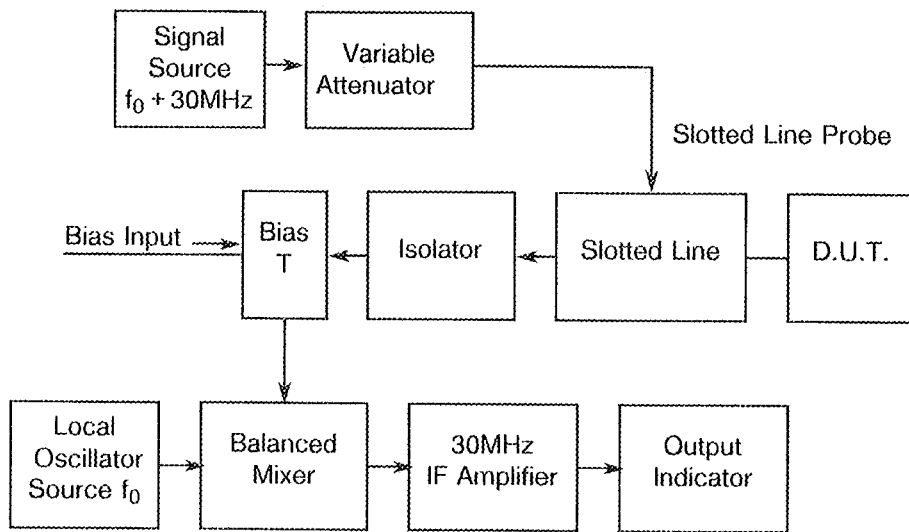

TABLE 5(a) - CONDITIONS FOR HIGH TEMPERATURE REVERSE BIAS BURN-IN

No.	CHARACTERISTICS	SYMBOL	CONDITIONS	UNIT
1	Ambient Temperature	T_{amb}	Variants 24, 49 and 74 : + 125(+ 0 - 3) All other Variants : + 150(+ 0 - 3)	°C
2	Reverse Voltage	V_R	Variants 01 to 50: - 20 Variants 51 to 99: - 35	V

TABLE 5(b) - CONDITIONS FOR POWER BURN-IN AND OPERATING LIFE TESTS

No.	CHARACTERISTICS	SYMBOL	CONDITIONS	UNIT
1	Ambient Temperature	T_{amb}	Variants 24, 49 and 74 : +115(+0-3) All other Variants : +125(+0-3)	°C
2	Forward Current	I_F	Variants 24, 49 and 74 : 10 All other Variants : 75	mA

FIGURE 5(a) - ELECTRICAL CIRCUIT FOR HIGH TEMPERATURE REVERSE BIAS BURN-IN

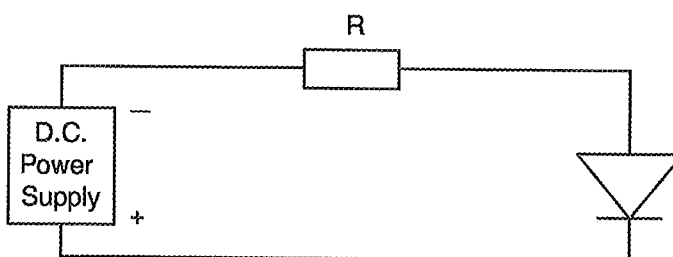
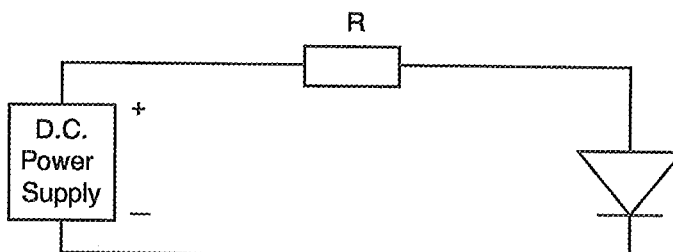

FIGURE 5(b) - ELECTRICAL CIRCUIT FOR POWER BURN-IN AND OPERATING LIFE TESTS





4.8 ENVIRONMENTAL AND ENDURANCE TESTS (CHARTS IV AND V OF ESA/SCC GENERIC SPECIFICATION NO. 5010)

4.8.1 Electrical Measurements on Completion of Environmental Tests

The parameters to be measured on completion of environmental tests are scheduled in Table 2. Unless otherwise stated, the measurements shall be performed at $T_{amb} = +22 \pm 3$ °C.

4.8.2 Electrical Measurements at Intermediate Points and on Completion of Endurance Tests

The parameters to be measured at intermediate points and on completion of endurance tests are scheduled in Table 6. Unless otherwise stated, the measurements shall be performed at $T_{amb} = +22 \pm 3$ °C.

4.8.3 Conditions for Operating Life Tests (Part of Endurance Testing)

The requirements for operating life testing are specified in Section 9 of ESA/SCC Generic Specification No. 5010. The conditions for operating life testing are specified in Table 5(b) of this specification.

4.8.4 Electrical Circuits for Operating Life Tests

The circuit to be used for performance of the operating life test shall be the same as shown in Figure 5(b) for Power Burn-in.

4.9 TOTAL DOSE IRRADIATION TESTING

4.9.1 Application

If specified in Para. 4.2.1 of this specification, total dose irradiation testing shall be performed in accordance with the requirements of ESA/SCC Basic Specification No. 22900.

4.9.2 Bias Conditions

Continuous bias shall be applied during irradiation testing as shown in Figure 6 of this specification.

4.9.3 Electrical Measurements

The parameters to be measured prior to irradiation exposure are scheduled in Table 2 of this specification. Only devices which meet the requirements of Table 2 shall be included in the test sample.

The parameters to be measured during and on completion of irradiation testing are scheduled in Table 7 of this specification.

4.10 SPECIAL TESTING

Not applicable.



TABLE 6 - ELECTRICAL MEASUREMENTS AT INTERMEDIATE POINTS AND ON COMPLETION OF ENDURANCE TESTING

No.	CHARACTERISTICS	SYMBOL	SPEC. AND/OR TEST METHOD	TEST CONDITIONS	LIMITS		UNIT
					MIN.	MAX.	
1	Reverse Current 1	I_{R1}	As per Table 2	As per Table 2	As per Table 2		μA
2	Reverse Current 2	I_{R2}	As per Table 2	As per Table 2	As per Table 2		nA
3	Forward Voltage	V_F	As per Table 2	As per Table 2	As per Table 2		V
5	Total Capacitance	C_T	As per Table 2	As per Table 2	As per Table 2		pF
7	Forward Slope Resistance	R_{FS}	As per Table 2	As per Table 2	As per Table 2		Ω

FIGURE 6 - BIAS CONDITIONS FOR IRRADIATION TESTING

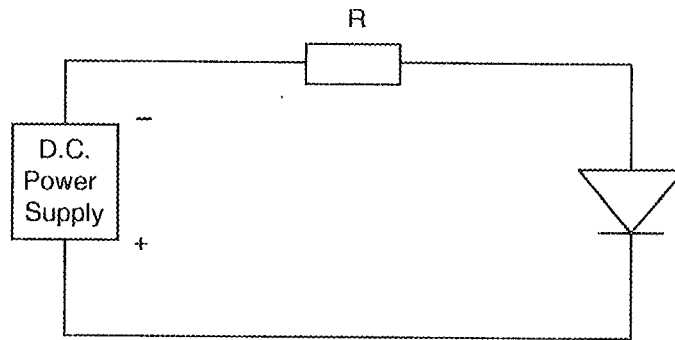

NOTES

1. A reverse bias of $V_R = -20V$ (Variants 01 to 50) or $-35V$ (Variants 51 to 99) shall be applied.

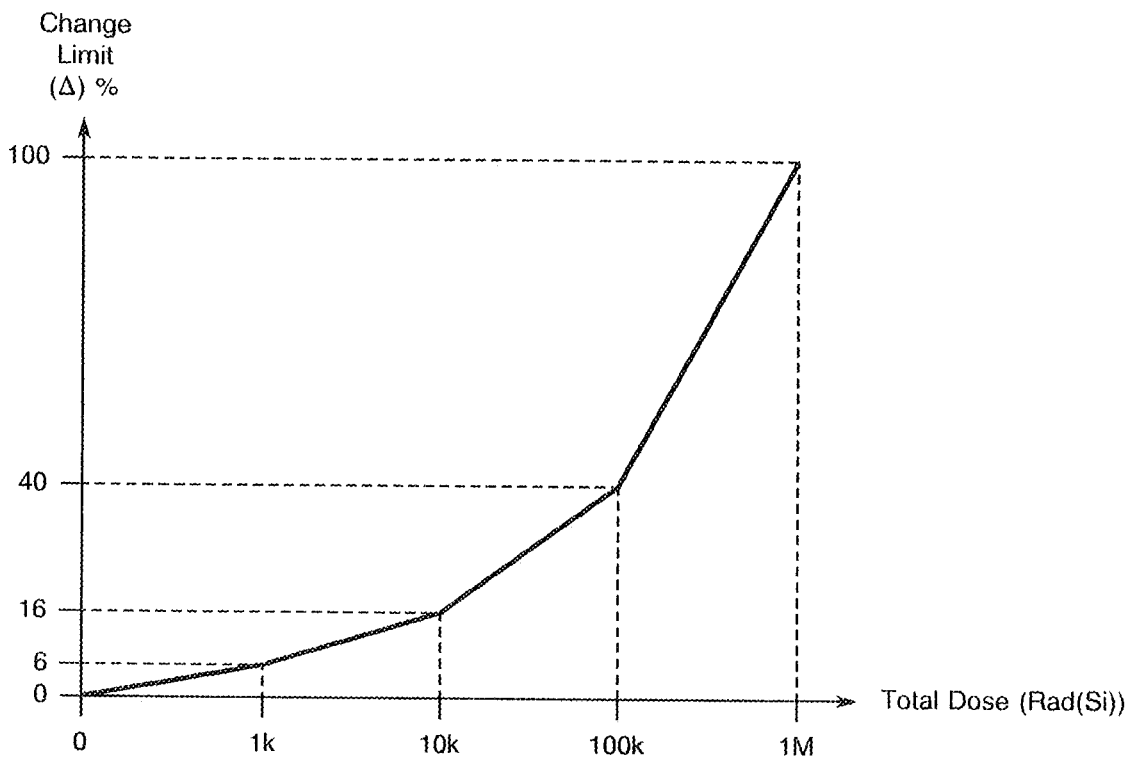



TABLE 7 - ELECTRICAL MEASUREMENTS DURING AND ON COMPLETION OF IRRADIATION TESTING

No.	CHARACTERISTICS	SYMBOL	SPEC. AND/OR TEST METHOD	TEST CONDITIONS	CHANGE LIMITS (Δ)	UNIT
6	Minority Carrier Lifetime	τ_L	As per Table 2	As per Table 2	Note 1	%

NOTES

1. The graph given below shall be used to determine the maximum permitted change.



	<p>ESA/SCC Detail Specification No. 5513/010</p>	<p>PAGE 38 ISSUE 1</p>
--	--	----------------------------

APPENDIX 'A'

Page 1 of 1

AGREED DEVIATIONS FOR M/A-Com LTD. (G.B.)

ITEMS AFFECTED	DESCRIPTION OF DEVIATIONS
Para. 4.2.2	Para. 9.4, "High Temperature Stabilisation Bake": May be performed at +125(+0 - 3) °C for Variants 24, 49 and 74.