



Pages 1 to 29

**CONNECTORS, ELECTRICAL, SINGLE-IN-LINE,
MICROMINIATURE,
BASED ON TYPE MTB 1**

ESCC Detail Specification No. 3401/031

ISSUE 3

March 2010



Document Custodian: European Space Agency - see <https://escies.org>



LEGAL DISCLAIMER AND COPYRIGHT

European Space Agency, Copyright © 2010. All rights reserved.

The European Space Agency disclaims any liability or responsibility, to any person or entity, with respect to any loss or damage caused, or alleged to be caused, directly or indirectly by the use and application of this ESCC publication.

This publication, without the prior permission of the European Space Agency and provided that it is not used for a commercial purpose, may be:

- copied in whole in any medium without alteration or modification.
- copied in part, in any medium, provided that the ESCC document identification, comprising the ESCC symbol, document number and document issue, is removed.

DOCUMENTATION CHANGE NOTICE

(Refer to <https://escies.org> for ESCC DCR content)

DCR No.	CHANGE DESCRIPTION
560	Specification upissued to incorporate technical changes per DCR.



TABLE OF CONTENTS

	<u>Page</u>
1. <u>GENERAL</u>	5
1.1 Scope	5
1.2 Component Type Variants/Range of Components	5
1.2.1 Shell Sizes for Variant 01	5
1.2.2 Shell Sizes for Variant 02	5
1.3 Maximum Ratings	5
1.4 Parameter Derating Information	5
1.5 Physical Dimensions	5
2. <u>APPLICABLE DOCUMENTS</u>	5
3. <u>TERMS, DEFINITIONS, ABBREVIATIONS, SYMBOLS AND UNITS</u>	17
4. <u>REQUIREMENTS</u>	17
4.1 General	17
4.2 Deviations from Generic Specification	17
4.2.1 Deviations from Special In-process Controls	17
4.2.2 Deviations from Final Production Tests	17
4.2.3 Deviations from Burn-in and Electrical Measurements	17
4.2.4 Deviations from Qualification Tests	17
4.2.5 Deviations from Lot Acceptance Tests	18
4.3 Mechanical Requirements	18
4.3.1 Dimension Check	18
4.3.2 Weight	18
4.3.3 Contact Capability	18
4.3.4 Contact Retention (In Insert)	18
4.3.5 Mating and Unmating Forces	18
4.3.6 Insert Retention (In Shell)	19
4.3.7 Jackscrew Retention	19
4.3.8 Contact Insertion and Withdrawal Forces	19
4.3.9 Engagement and Separation Forces (Male Contacts)	19
4.3.10 Oversize Pin Exclusion	19
4.3.11 Probe Damage	19
4.3.12 Solderability	19
4.3.13 Latching	19
4.4 Materials and Finishes	19
4.4.1 Inserts	19
4.4.2 Contacts	20
4.4.3 Guide Posts	20
4.4.4 Latching	20
4.4.5 Insulated Wires	20
4.4.6 Uninsulated Solid Wires	20
4.4.7 Rear Potting	20
4.5 Marking	20
4.5.1 General	20
4.5.2 Contact Identification	21
4.5.3 The ESCC Component Number	21
4.5.4 Characteristics	21
4.5.5 Traceability Information	22



	<u>Page</u>	
4.6	Electrical Measurements	22
4.6.1	Electrical Measurements at Room Temperature	22
4.6.2	Electrical Measurements at High and Low Temperatures	22
4.6.3	Circuits for Electrical Measurements	22
4.7	Burn-in and Electrical Measurements	22
4.8	Environmental and Endurance Tests	25
4.8.1	Measurements and Inspections on Completion of Environmental Tests	25
4.8.2	Measurements and Inspections at Intermediate Points during Endurance Tests	25
4.8.3	Measurements and Inspections on Completion of Endurance Tests	25
4.8.4	Conditions for Operating Life Tests	25
4.8.5	Electrical Circuits for Operating Life Tests	25
4.8.6	Conditions for High Temperature Storage Test	25

TABLES

1(a)	Type Variants	6
1(b)	Maximum Weights	6
1(c)	Engagements and Separation Forces	6
1(d)	Maximum Ratings	6
2	Electrical Measurements at Room Temperature	23
3	Not Applicable	23
4	Not Applicable	23
5	Not Applicable	23
6	Measurements and Inspections on Completion of Environmental and Endurance Tests	26

FIGURES

1	Parameter Derating Information	7
1(a)	Working Voltage Versus Altitude	7
1(b)	Maximum Current Versus Number of Contacts	7
2	Physical Dimensions	8
2.1(a)	Connectors Plug - Male Contacts	8
2.1(b)	Connectors Receptacle - Female Contacts	11
2.2	Uninsulated Solid Wires	14
2.3	Insulated Wires	14
2.4	Latching	15
2.5	Contact Position	16
3	Gauge Fixture	24
4	Not Applicable	N/A
5	Not Applicable	N/A

APPENDICES (Applicable to specific Manufacturers only)

'A'	C&K COMPONENTS (F)	29
-----	--------------------	----



1. GENERAL

1.1 SCOPE

This specification details the ratings, physical and electrical characteristics, test and inspection data for Connectors, Electrical, Single-in-Line, Microminiature, based on Type MTB 1, with non-removable crimp-type contacts and their associated insulated wires and uninsulated solid wires.

It shall be read in conjunction with:

- (a) ESCC Generic Specification No. 3401 for Connectors, Electrical, Non-filtered, Circular and Rectangular,

the requirements of which are supplemented herein.

1.2 COMPONENT TYPE VARIANTS / RANGE OF COMPONENTS

The single-in-line connectors specified herein are scheduled in Table 1(a). Alignment is effected by 2 guide posts; the posts are located at either end of the receptacle.

1.2.1 Shell sizes for Variant 01

These range from 5 to 81. Since 4 cavities are used (2 guide posts and 2 epoxy-filled cavities at either end) the number of available contact positions ranges from 1 to 77.

1.2.2 Shell sizes for Variant 02

These range from 6 to 81. Since 5 cavities are used (2 guide posts and 2 epoxy-filled cavities at either end plus 1 cavity for latching) the number of available contact positions ranges from 1 to 76.

Polarisation may be achieved by means of additional guide posts (according to Customer requirements). The different sizes of associated insulated wires and uninsulated solid wires are given in Figure 2. For bodies with more than 41 cavities, additional back-potting is necessary.

1.3 MAXIMUM RATINGS

The maximum ratings, which shall not be exceeded at any time during use or storage, applicable to the connectors specified herein, are scheduled in Table 1(d).

1.4 PARAMETER DERATING INFORMATION

The applicable derating information for the contacts specified herein is shown in Figure 1(a).

1.5 PHYSICAL DIMENSIONS

The physical dimensions of the connectors, insulated wires and uninsulated solid wires specified herein are shown in Figure 2.

2. APPLICABLE DOCUMENTS

The following documents form part of this specification and shall be read in conjunction with it:-

- (a) ESCC Generic Specification No. 3401, Connectors, Electrical, Non-filtered, Circular and Rectangular.
- (b) ESCC Detail Specification No. 3901/013, PTFE Insulated Wires and Cables, 600V -100 to +200 °C.
- (c) QQ-W-343, Wires, Electrical, Uninsulated.
- (d) MIL-G-45204, Gold-plating, Electro-deposited.
- (e) MIL-C-14550, Copper-plating, Electro-deposited.



TABLE 1(a) - TYPE VARIANTS

VARIANT	LATCHING OPTION
01	Without latching
02	With latching

TABLE 1(b) - MAXIMUM WEIGHTS

DESCRIPTION		WEIGHT (g)
Contact	Male	0.02
	Female	0.02
Body (per contact cavity)	Plug	0.21
	Receptacle	0.006
Guide Post, Stainless Steel (2 per connector)	-	0.035
Wire	Figures 2.2 and 2.3	

TABLE 1(c) - MATING AND UNMATING FORCES

DESCRIPTION	MATING		UNMATING	
	MIN.	MAX.	MIN.	MAX.
Per contact	-	2.2N	0.14N	2.2N

TABLE 1(d) - MAXIMUM RATINGS

No.	CHARACTERISTICS	SYMBOL	MAXIMUM RATING	UNIT
1	Working Voltage (Sea Level)	U_R	150	Vrms
2	Rated Current (AWG26 and Uninsulated Solid Wire)	I_R	2.5	A
3	Rated Current (AWG28)	I_R	1.5	A
4	Operating Temperature Range	T_{op}	-55 to +125	°C
5	Storage Temperature Range	T_{stg}	-55 to +125	°C

FIGURE 1 - PARAMETER DERATING INFORMATION

FIGURE 1(a) - WORKING VOLTAGE VERSUS ALTITUDE

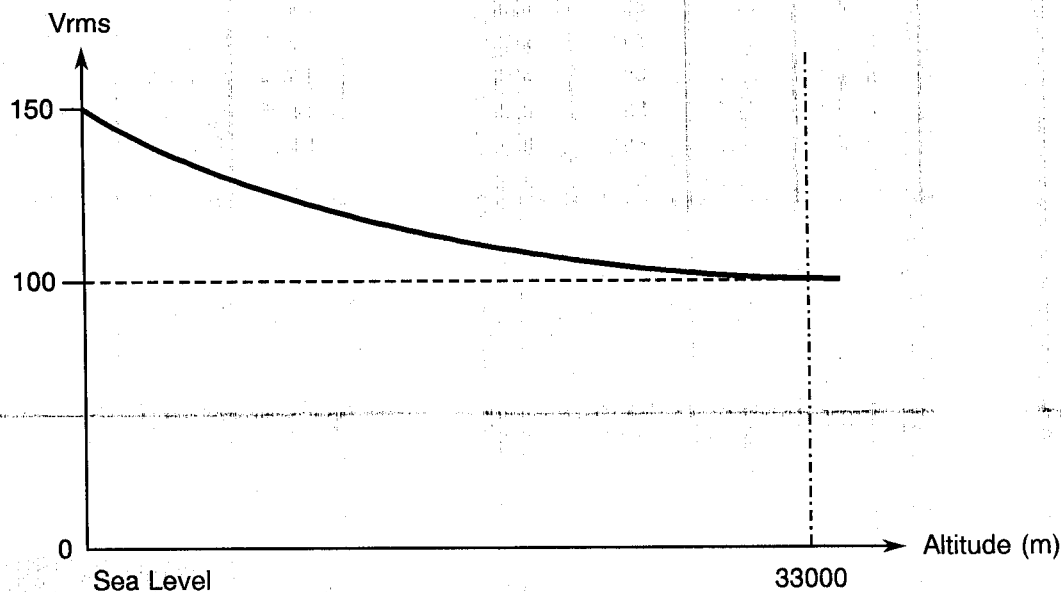
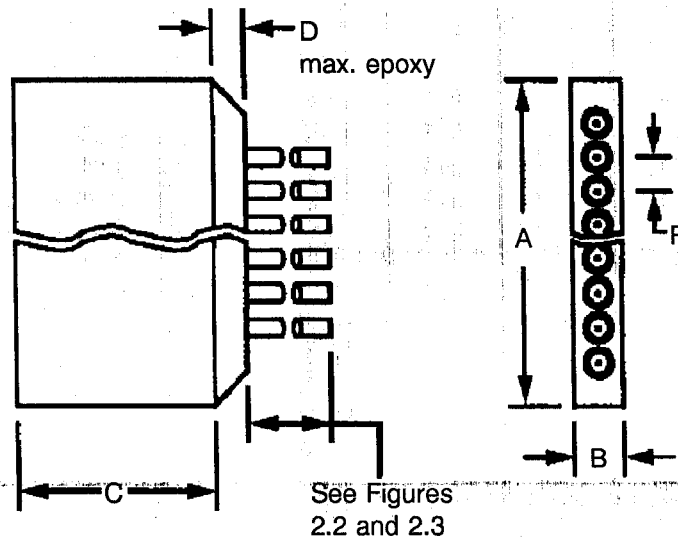

FIGURE 1(b) - MAXIMUM CURRENT VERSUS NUMBER OF CONTACTS

NUMBER OF CONTACTS PER CONNECTOR	MAXIMUM CURRENT PER CONTACT	
	WIRE SIZE	
	AWG26 AND UNINSULATED SOLID WIRE	AWG28
2-4	2.0	1.4
5-14	1.8	1.2
15 and over	1.4	0.9

FIGURE 2 - PHYSICAL DIMENSIONS

FIGURE 2.1(a) - CONNECTORS PLUG - MALE CONTACTS



Shell Size	A		B		C		D	F
	Min.	Max.	Min.	Max.	Min.	Max.	Max.	Typical
5	6.47	7.23	1.9	2.16	7.06	7.32	3.18	1.27
6	7.75	8.51	1.9	2.16	7.06	7.32	3.18	1.27
7	9.02	9.78	1.9	2.16	7.06	7.32	3.18	1.27
8	10.29	11.05	1.9	2.16	7.06	7.32	3.18	1.27
9	11.56	12.32	1.9	2.16	7.06	7.32	3.18	1.27
10	12.82	13.58	1.9	2.16	7.06	7.32	3.18	1.27
11	14.10	14.86	1.9	2.16	7.06	7.32	3.18	1.27
12	15.37	16.13	1.9	2.16	7.06	7.32	3.18	1.27
13	16.64	17.40	1.9	2.16	7.06	7.32	3.18	1.27
14	17.91	18.67	1.9	2.16	7.06	7.32	3.18	1.27
15	19.18	20.04	1.9	2.16	7.06	7.32	3.18	1.27
16	20.45	21.21	1.9	2.16	7.06	7.32	3.18	1.27
17	21.72	22.48	1.9	2.16	7.06	7.32	3.18	1.27
18	22.99	23.75	1.9	2.16	7.06	7.32	3.18	1.27
19	24.26	25.02	1.9	2.16	7.06	7.32	3.18	1.27
20	25.53	26.29	1.9	2.16	7.06	7.32	3.18	1.27
21	26.8	27.56	1.9	2.16	7.06	7.32	3.18	1.27
22	28.07	28.83	1.9	2.16	7.06	7.32	3.18	1.27
23	29.34	30.10	1.9	2.16	7.06	7.32	3.18	1.27
24	30.61	31.47	1.9	2.16	7.06	7.32	3.18	1.27
25	31.88	32.64	1.9	2.16	7.06	7.32	3.18	1.27

NOTES

1. All dimensions are in millimetres.

FIGURE 2 - PHYSICAL DIMENSIONS (CONTINUED)

FIGURE 2.1(a) - CONNECTORS PLUG - MALE CONTACTS (CONTINUED)

Shell Size	A		B		C		D	F
	Min.	Max.	Min.	Max.	Min.	Max.	Max.	Typical
26	33.15	33.91	1.9	2.16	7.06	7.32	3.18	1.27
27	34.42	35.18	1.9	2.16	7.06	7.32	3.18	1.27
28	35.69	46.45	1.9	2.16	7.06	7.32	3.18	1.27
29	36.96	37.72	1.9	2.16	7.06	7.32	3.18	1.27
30	38.23	38.99	1.9	2.16	7.06	7.32	3.18	1.27
31	39.5	40.26	1.9	2.16	7.06	7.32	3.18	1.27
32	40.77	41.53	1.9	2.16	7.06	7.32	3.18	1.27
33	42.04	42.8	1.9	2.16	7.06	7.32	3.18	1.27
34	43.31	44.07	1.9	2.16	7.06	7.32	3.18	1.27
35	44.58	45.34	1.9	2.16	7.06	7.32	3.18	1.27
36	45.85	46.61	1.9	2.16	7.06	7.32	3.18	1.27
37	47.12	47.88	1.9	2.16	7.06	7.32	3.18	1.27
38	48.39	49.15	1.9	2.16	7.06	7.32	3.18	1.27
39	49.66	50.42	1.9	2.16	7.06	7.32	3.18	1.27
40	50.93	51.69	1.9	2.16	7.06	7.32	3.18	1.27
41	52.2	52.96	1.9	2.16	7.06	7.32	3.18	1.27
42	53.47	54.23	1.9	2.16	7.06	7.32	3.18	1.27
43	54.74	55.5	1.9	2.16	7.06	7.32	3.18	1.27
44	56.01	56.77	1.9	2.16	7.06	7.32	3.18	1.27
45	57.28	58.04	1.9	2.16	7.06	7.32	3.18	1.27
46	58.55	59.31	1.9	2.16	7.06	7.32	3.18	1.27
47	59.82	60.58	1.9	2.16	7.06	7.32	3.18	1.27
48	61.09	61.85	1.9	2.16	7.06	7.32	3.18	1.27
49	62.36	63.12	1.9	2.16	7.06	7.32	3.18	1.27
50	63.63	64.39	1.9	2.16	7.06	7.32	3.18	1.27
51	64.9	65.66	1.9	2.16	7.06	7.32	3.18	1.27
52	66.13	66.89	1.9	2.16	7.06	7.32	3.18	1.27
53	67.44	68.2	1.9	2.16	7.06	7.32	3.18	1.27
54	68.71	69.47	1.9	2.16	7.06	7.32	3.18	1.27
55	69.98	70.74	1.9	2.16	7.06	7.32	3.18	1.27
56	71.25	72.01	1.9	2.16	7.06	7.32	3.18	1.27
57	72.52	73.28	1.9	2.16	7.06	7.32	3.18	1.27
58	73.79	74.54	1.9	2.16	7.06	7.32	3.18	1.27
59	75.06	75.82	1.9	2.16	7.06	7.32	3.18	1.27
60	76.33	77.09	1.9	2.16	7.06	7.32	3.18	1.27
61	76.6	78.36	1.9	2.16	7.06	7.32	3.18	1.27
62	78.87	79.53	1.9	2.16	7.06	7.32	3.18	1.27
63	80.14	80.9	1.9	2.16	7.06	7.32	3.18	1.27
64	81.41	82.37	1.9	2.16	7.06	7.32	3.18	1.27
65	82.68	83.44	1.9	2.16	7.06	7.32	3.18	1.27

NOTES

1. All dimensions are in millimetres.

FIGURE 2 - PHYSICAL DIMENSIONS (CONTINUED)

FIGURE 2.1(a) - CONNECTORS PLUG - MALE CONTACTS (CONTINUED)

Shell Size	A		B		C		D	F
	Min.	Max.	Min.	Max.	Min.	Max.	Max.	Typical
66	83.95	84.71	1.9	2.16	7.06	7.32	3.18	1.27
67	85.22	86.08	1.9	2.16	7.06	7.32	3.18	1.27
68	86.39	87.15	1.9	2.16	7.06	7.32	3.18	1.27
69	87.76	88.52	1.9	2.16	7.06	7.32	3.18	1.27
70	89.03	89.79	1.9	2.16	7.06	7.32	3.18	1.27
71	90.3	91.06	1.9	2.16	7.06	7.32	3.18	1.27
72	91.57	92.33	1.9	2.16	7.06	7.32	3.18	1.27
73	92.84	93.6	1.9	2.16	7.06	7.32	3.18	1.27
74	94.11	94.87	1.9	2.16	7.06	7.32	3.18	1.27
75	95.38	96.14	1.9	2.16	7.06	7.32	3.18	1.27
76	96.65	97.41	1.9	2.16	7.06	7.32	3.18	1.27
77	97.92	98.68	1.9	2.16	7.06	7.32	3.18	1.27
78	98.19	99.05	1.9	2.16	7.06	7.32	3.18	1.27
79	100.46	101.22	1.9	2.16	7.06	7.32	3.18	1.27
80	101.73	102.49	1.9	2.16	7.06	7.32	3.18	1.27
81	103	103.76	1.9	2.16	7.06	7.32	3.18	1.27

NOTES

1. All dimensions are in millimetres.

FIGURE 2 - PHYSICAL DIMENSIONS (CONTINUED)

FIGURE 2.1(b) - CONNECTORS RECEPTACLE - FEMALE CONTACTS

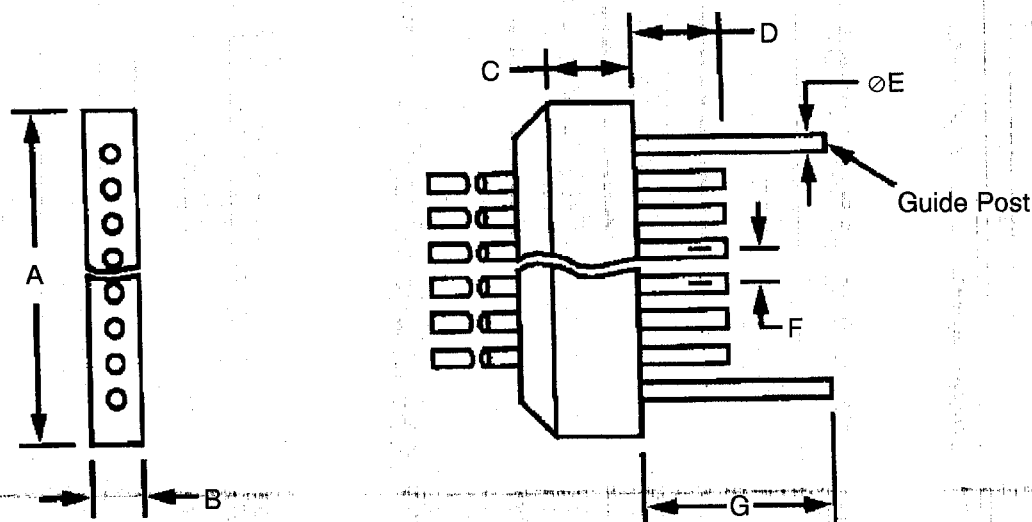

Shell Size	A		B		C		D		$\varnothing E$		F	G	
	Min.	Max.	Min.	Max.	Min.	Max.	Min.	Max.	Min.	Max.	Typical	Min.	Max.
5	6.47	7.23	1.9	2.16	2.41	2.67	3.07	3.33	0.78	0.84	1.27	4.83	5.33
6	7.75	8.51	1.9	2.16	2.41	2.67	3.07	3.33	0.78	0.84	1.27	4.83	5.33
7	9.02	9.78	1.9	2.16	2.41	2.67	3.07	3.33	0.78	0.84	1.27	4.83	5.33
8	10.29	11.05	1.9	2.16	2.41	2.67	3.07	3.33	0.78	0.84	1.27	4.83	5.33
9	11.56	12.32	1.9	2.16	2.41	2.67	3.07	3.33	0.78	0.84	1.27	4.83	5.33
10	12.82	13.58	1.9	2.16	2.41	2.67	3.07	3.33	0.78	0.84	1.27	4.83	5.33
11	14.1	14.86	1.9	2.16	2.41	2.67	3.07	3.33	0.78	0.84	1.27	4.83	5.33
12	15.37	16.13	1.9	2.16	2.41	2.67	3.07	3.33	0.78	0.84	1.27	4.83	5.33
13	16.64	17.4	1.9	2.16	2.41	2.67	3.07	3.33	0.78	0.84	1.27	4.83	5.33
14	17.91	18.67	1.9	2.16	2.41	2.67	3.07	3.33	0.78	0.84	1.27	4.83	5.33
15	19.18	20.04	1.9	2.16	2.41	2.67	3.07	3.33	0.78	0.84	1.27	4.83	5.33
16	20.45	21.21	1.9	2.16	2.41	2.67	3.07	3.33	0.78	0.84	1.27	4.83	5.33
17	21.72	22.48	1.9	2.16	2.41	2.67	3.07	3.33	0.78	0.84	1.27	4.83	5.33
18	22.99	23.75	1.9	2.16	2.41	2.67	3.07	3.33	0.78	0.84	1.27	4.83	5.33
19	24.26	25.02	1.9	2.16	2.41	2.67	3.07	3.33	0.78	0.84	1.27	4.83	5.33
20	25.53	26.29	1.9	2.16	2.41	2.67	3.07	3.33	0.78	0.84	1.27	4.83	5.33
21	26.8	27.56	1.9	2.16	2.41	2.67	3.07	3.33	0.78	0.84	1.27	4.83	5.33
22	28.07	28.83	1.9	2.16	2.41	2.67	3.07	3.33	0.78	0.84	1.27	4.83	5.33
23	29.34	30.1	1.9	2.16	2.41	2.67	3.07	3.33	0.78	0.84	1.27	4.83	5.33
24	30.61	31.47	1.9	2.16	2.41	2.67	3.07	3.33	0.78	0.84	1.27	4.83	5.33
25	31.88	32.64	1.9	2.16	2.41	2.67	3.07	3.33	0.78	0.84	1.27	4.83	5.33

NOTES

1. All dimensions are in millimetres.



FIGURE 2 - PHYSICAL DIMENSIONS (CONTINUED)

FIGURE 2.1(b) - CONNECTORS RECEPTACLE - FEMALE CONTACTS (CONTINUED)

Shell Size	A		B		C		D		ØE		F	G	
	Min.	Max.	Min.	Max.	Min.	Max.	Min.	Max.	Min.	Max.	Typical	Min.	Max.
26	33.15	33.91	1.9	2.16	2.41	2.67	3.07	3.33	0.78	0.84	1.27	4.83	5.33
27	34.42	35.18	1.9	2.16	2.41	2.67	3.07	3.33	0.78	0.84	1.27	4.83	5.33
28	35.69	46.45	1.9	2.16	2.41	2.67	3.07	3.33	0.78	0.84	1.27	4.83	5.33
29	36.96	37.72	1.9	2.16	2.41	2.67	3.07	3.33	0.78	0.84	1.27	4.83	5.33
30	38.23	38.99	1.9	2.16	2.41	2.67	3.07	3.33	0.78	0.84	1.27	4.83	5.33
31	39.5	40.26	1.9	2.16	2.41	2.67	3.07	3.33	0.78	0.84	1.27	4.83	5.33
32	40.77	41.53	1.9	2.16	2.41	2.67	3.07	3.33	0.78	0.84	1.27	4.83	5.33
33	42.04	42.8	1.9	2.16	2.41	2.67	3.07	3.33	0.78	0.84	1.27	4.83	5.33
34	43.31	44.07	1.9	2.16	2.41	2.67	3.07	3.33	0.78	0.84	1.27	4.83	5.33
35	44.58	45.34	1.9	2.16	2.41	2.67	3.07	3.33	0.78	0.84	1.27	4.83	5.33
36	45.85	46.61	1.9	2.16	2.41	2.67	3.07	3.33	0.78	0.84	1.27	4.83	5.33
37	47.12	47.88	1.9	2.16	2.41	2.67	3.07	3.33	0.78	0.84	1.27	4.83	5.33
38	48.39	49.15	1.9	2.16	2.41	2.67	3.07	3.33	0.78	0.84	1.27	4.83	5.33
39	49.66	50.42	1.9	2.16	2.41	2.67	3.07	3.33	0.78	0.84	1.27	4.83	5.33
40	50.93	51.69	1.9	2.16	2.41	2.67	3.07	3.33	0.78	0.84	1.27	4.83	5.33
41	52.2	52.96	1.9	2.16	2.41	2.67	3.07	3.33	0.78	0.84	1.27	4.83	5.33
42	53.47	54.23	1.9	2.16	2.41	2.67	3.07	3.33	0.78	0.84	1.27	4.83	5.33
43	54.74	55.5	1.9	2.16	2.41	2.67	3.07	3.33	0.78	0.84	1.27	4.83	5.33
44	56.01	56.77	1.9	2.16	2.41	2.67	3.07	3.33	0.78	0.84	1.27	4.83	5.33
45	57.28	58.04	1.9	2.16	2.41	2.67	3.07	3.33	0.78	0.84	1.27	4.83	5.33
46	58.55	59.31	1.9	2.16	2.41	2.67	3.07	3.33	0.78	0.84	1.27	4.83	5.33
47	59.82	60.58	1.9	2.16	2.41	2.67	3.07	3.33	0.78	0.84	1.27	4.83	5.33
48	61.09	61.85	1.9	2.16	2.41	2.67	3.07	3.33	0.78	0.84	1.27	4.83	5.33
49	62.36	63.12	1.9	2.16	2.41	2.67	3.07	3.33	0.78	0.84	1.27	4.83	5.33
50	63.63	64.39	1.9	2.16	2.41	2.67	3.07	3.33	0.78	0.84	1.27	4.83	5.33
51	64.9	65.66	1.9	2.16	2.41	2.67	3.07	3.33	0.78	0.84	1.27	4.83	5.33
52	66.13	66.89	1.9	2.16	2.41	2.67	3.07	3.33	0.78	0.84	1.27	4.83	5.33
53	67.44	68.2	1.9	2.16	2.41	2.67	3.07	3.33	0.78	0.84	1.27	4.83	5.33
54	68.71	69.47	1.9	2.16	2.41	2.67	3.07	3.33	0.78	0.84	1.27	4.83	5.33
55	69.98	70.74	1.9	2.16	2.41	2.67	3.07	3.33	0.78	0.84	1.27	4.83	5.33
56	71.25	72.01	1.9	2.16	2.41	2.67	3.07	3.33	0.78	0.84	1.27	4.83	5.33
57	72.52	73.28	1.9	2.16	2.41	2.67	3.07	3.33	0.78	0.84	1.27	4.83	5.33
58	73.79	74.54	1.9	2.16	2.41	2.67	3.07	3.33	0.78	0.84	1.27	4.83	5.33
59	75.06	75.82	1.9	2.16	2.41	2.67	3.07	3.33	0.78	0.84	1.27	4.83	5.33
60	76.33	77.09	1.9	2.16	2.41	2.67	3.07	3.33	0.78	0.84	1.27	4.83	5.33
61	77.6	78.36	1.9	2.16	2.41	2.67	3.07	3.33	0.78	0.84	1.27	4.83	5.33
62	78.87	79.53	1.9	2.16	2.41	2.67	3.07	3.33	0.78	0.84	1.27	4.83	5.33
63	80.14	80.9	1.9	2.16	2.41	2.67	3.07	3.33	0.78	0.84	1.27	4.83	5.33
64	81.41	82.37	1.9	2.16	2.41	2.67	3.07	3.33	0.78	0.84	1.27	4.83	5.33
65	82.68	83.44	1.9	2.16	2.41	2.67	3.07	3.33	0.78	0.84	1.27	4.83	5.33

NOTES

1. All dimensions are in millimetres.



FIGURE 2 - PHYSICAL DIMENSIONS (CONTINUED)

FIGURE 2.1(b) - CONNECTORS RECEPTACLE - FEMALE CONTACTS (CONTINUED)

Shell Size	A		B		C		D		ØE		F	G	
	Min.	Max.	Min.	Max.	Min.	Max.	Min.	Max.	Min.	Max.	Typical	Min.	Max.
66	83.95	84.71	1.9	2.16	2.41	2.67	3.07	3.33	0.78	0.84	1.27	4.83	5.33
67	85.22	86.08	1.9	2.16	2.41	2.67	3.07	3.33	0.78	0.84	1.27	4.83	5.33
68	86.39	87.15	1.9	2.16	2.41	2.67	3.07	3.33	0.78	0.84	1.27	4.83	5.33
69	87.76	88.52	1.9	2.16	2.41	2.67	3.07	3.33	0.78	0.84	1.27	4.83	5.33
70	89.03	89.79	1.9	2.16	2.41	2.67	3.07	3.33	0.78	0.84	1.27	4.83	5.33
71	90.3	91.06	1.9	2.16	2.41	2.67	3.07	3.33	0.78	0.84	1.27	4.83	5.33
72	91.57	92.33	1.9	2.16	2.41	2.67	3.07	3.33	0.78	0.84	1.27	4.83	5.33
73	92.84	93.6	1.9	2.16	2.41	2.67	3.07	3.33	0.78	0.84	1.27	4.83	5.33
74	94.11	94.87	1.9	2.16	2.41	2.67	3.07	3.33	0.78	0.84	1.27	4.83	5.33
75	95.38	96.14	1.9	2.16	2.41	2.67	3.07	3.33	0.78	0.84	1.27	4.83	5.33
76	96.65	97.41	1.9	2.16	2.41	2.67	3.07	3.33	0.78	0.84	1.27	4.83	5.33
77	97.92	98.68	1.9	2.16	2.41	2.67	3.07	3.33	0.78	0.84	1.27	4.83	5.33
78	98.19	99.05	1.9	2.16	2.41	2.67	3.07	3.33	0.78	0.84	1.27	4.83	5.33
79	100.46	101.22	1.9	2.16	2.41	2.67	3.07	3.33	0.78	0.84	1.27	4.83	5.33
80	101.73	102.49	1.9	2.16	2.41	2.67	3.07	3.33	0.78	0.84	1.27	4.83	5.33
81	103	103.76	1.9	2.16	2.41	2.67	3.07	3.33	0.78	0.84	1.27	4.83	5.33

NOTES

1. All dimensions are in millimetres.

FIGURE 2 - PHYSICAL DIMENSIONS (CONTINUED)

FIGURE 2.2 - UNINSULATED SOLID WIRES

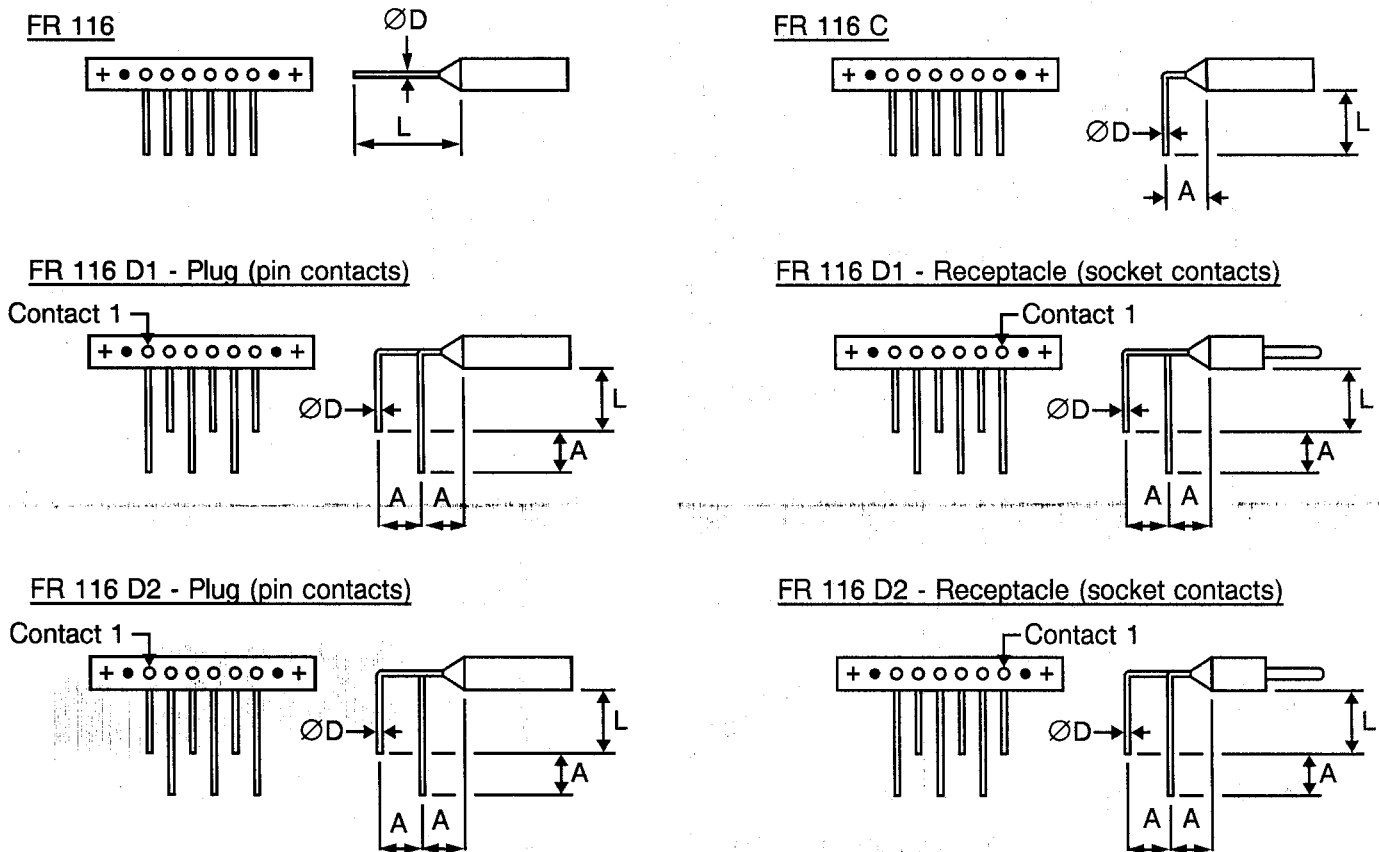

TERMINATIONS CODE	FR 116	FR 116 C	FR 116 D1	FR 116 D2
Wire Size (AWG)	25	25	25	25
Max. Diameter 'D' (mm)	0.46	0.46	0.46	0.46
Min. Diameter 'D' (mm)	0.45	0.45	0.45	0.45
Max. Weight (g/m)	1.60	1.60	1.60	1.60
Min. Gold-plating Thickness (μm)	0.50	0.50	0.50	0.50
L (mm)	25	4	4	4
A (mm)	-	2.54	2.54	2.54

FIGURE 2.3 - INSULATED WIRES

WIRE SIZE AWG		26	28
Conductor Characteristics	Maximum diameter (mm)	0.50	0.42
	Nominal cross-section (mm^2)	0.14	0.10
Finished Wire Characteristics	Maximum diameter (mm)	0.89	0.82
	Maximum weight (g/m)	2.3	1.8
	Colour	Natural	Natural
	Minimum length	See Para. 4.5.4.3	

FIGURE 2 - PHYSICAL DIMENSIONS (CONTINUED)

FIGURE 2.4 - LATCHING

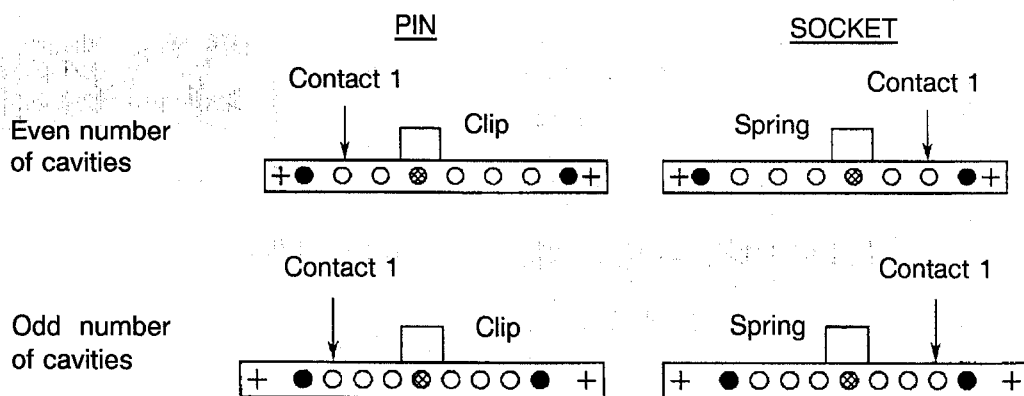
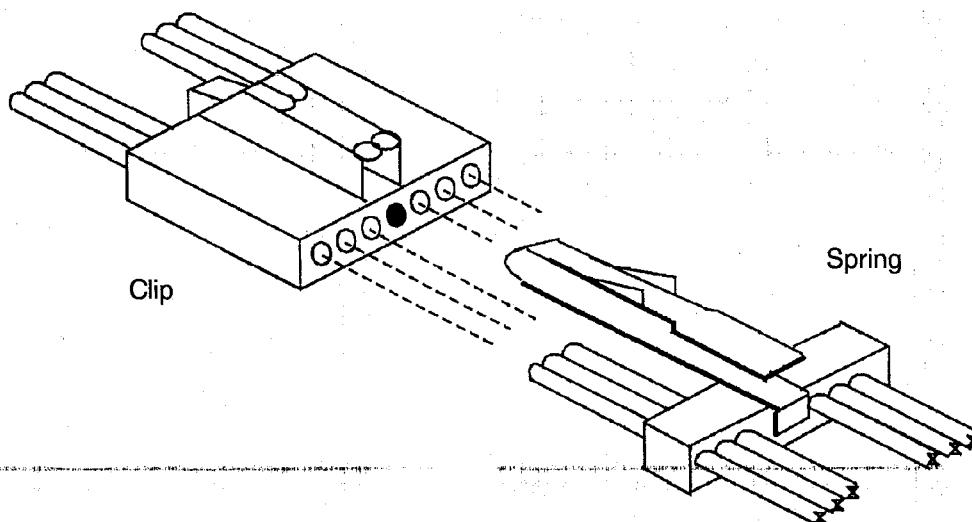

(Seen from contact side)

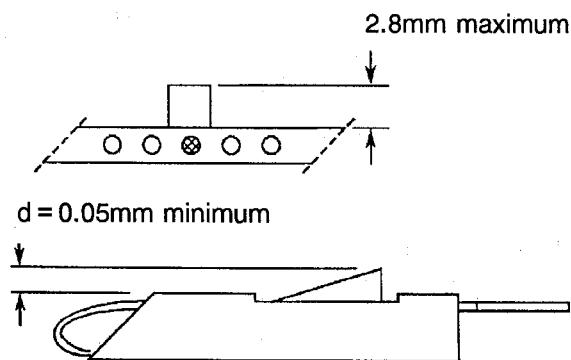

Latching force = 10N maximum

FIGURE 2 - PHYSICAL DIMENSIONS (CONTINUED)

FIGURE 2.5 - CONTACT POSITION

Figure 2.5.1 - Mounting Condition

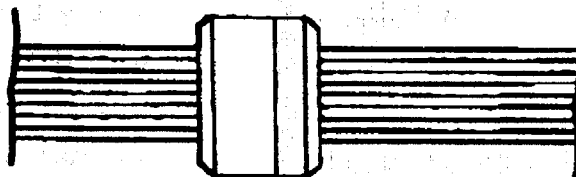

Figure 2.5.2 - Plug Male Contact

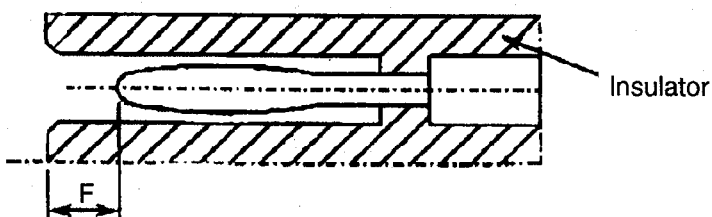
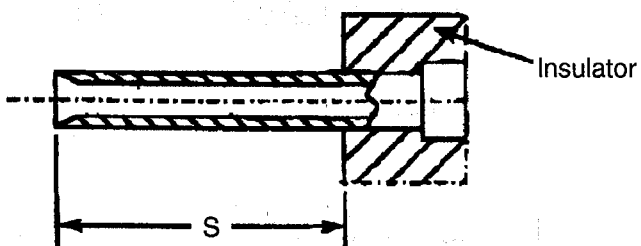

Figure 2.5.3 - Receptacle Female Contact



F		S	
Min.	Max.	Min.	Max.
0.25	0.91	3.07	3.33

NOTES

1. All dimensions are in millimetres.

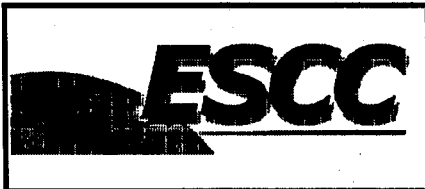

3. TERMS, DEFINITIONS, ABBREVIATIONS, SYMBOLS AND UNITS

For the purpose of this specification, the terms, definitions, abbreviations, symbols and units specified in ESCC Basic Specification No. 21300 shall apply.

4. REQUIREMENTS

4.1 GENERAL

The complete requirements for procurement of the connectors specified herein are as stated in this specification and ESCC Generic Specification No. 3401. Deviations from the Generic Specification, applicable to this specification only, are listed in Para. 4.2.

Deviations from the applicable Generic Specification and this Detail Specification, formally agreed with specific Manufacturers on the basis that the alternative requirements are equivalent to the ESCC requirements and do not affect the components' reliability, are listed in the appendices attached to this specification.

4.2 DEVIATIONS FROM GENERIC SPECIFICATION

4.2.1 Deviations from Special In-process Controls

- (a) Para. 9.15, Joint Strength: The contacts shall be crimped to insulated stranded wire AWG26 and AWG28 and to uninsulated solid wire AWG25. The value of failure shall be recorded together with the information as to whether the failure was "pull-out", "break in crimp" or "break in wire". The minimum tensile strength shall be as follows.

WIRE	MALE AND FEMALE CONTACTS		
	AWG26	AWG28	AWG25 - Solid Uninsulated
Tensile Strength (N)	22	13	22

4.2.2 Deviations from Final Production Tests (Chart II)

- (a) Para. 9.1.1.4, Mated Shell Conductivity: Not applicable.
- (b) Para. 9.3, Contact Retainer Test: Not applicable.
- (c) Para. 9.4, Contact Capability: This test shall be performed on male contacts. For details see Para. 4.3.3 of this specification.
- (d) Para. 9.5, Magnetism Level: Not applicable.

4.2.3 Deviations from Burn-in and Electrical Measurements (Chart III)

Not applicable.

4.2.4 Deviations from Qualification Tests (Chart IV)

- (a) Para. 9.1.1.4, Mated Shell Conductivity: Not applicable.
- (b) Para. 9.9, Seal Test: Not applicable.
- (c) Para. 9.15, Joint Strength: Not applicable.
- (d) Para. 9.17, Contact Retention (In Insert): Not applicable with male contact.
- (e) Para. 9.27, Maintenance Ageing: Not applicable.

- (f) Para. 9.29, Oversize Pin Exclusion: Not applicable.
- (g) Para. 9.30, Probe Damage: Not applicable.
- (h) Latching shall be performed as specified in Para. 4.3.13 of this specification.

4.2.5 Deviations from Lot Acceptance Tests (Chart V)

- (a) Para. 9.1.1.4, Mated Shell Conductivity: Not applicable.
- (b) Para. 9.9, Seal Test: Not applicable.
- (c) Para. 9.15, Joint Strength: Not applicable.
- (d) Para. 9.17, Contact Retention (In Insert): Not applicable with male contact.
- (e) Para. 9.27, Maintenance Ageing: Not applicable.
- (f) Para. 9.29, Oversize Pin Exclusion: Not applicable.
- (g) Para. 9.30, Probe Damage: Not applicable.
- (h) Latching shall be performed as specified in Para. 4.3.13 of this specification.

4.3 MECHANICAL REQUIREMENTS

4.3.1 Dimension Check

The dimensions of the connectors specified herein shall be verified in accordance with the requirements set out in Para. 9.6 of ESCC Generic Specification No. 3401 and shall conform to those shown in Figure 2 of this specification. Only the underlined dimensions shall be checked during procurement.

4.3.2 Weight

The maximum weight of the connectors specified herein shall be calculated on the basis of, and be in accordance with, the values given in Table 1(b) and in Figures 2.2 and 2.3 of this specification.

4.3.3 Contact Capability

For the purpose of this test, the pick-up and drop weights shall be as follows.

MEASUREMENTS	PICK-UP WEIGHT	DROP WEIGHT
Weight (g)	14	170
Inner Gauge Diameter (mm) (1)	0.582 - 0.587	0.559 - 0.564
Insertion Depth (mm)	1.5	1.5

NOTES

1. See Figure 3 for $\varnothing A$.

4.3.4 Contact Retention (In Insert)

Contact retention within the insert shall be 22.25 Newtons. There shall be no displacement of the contact. Not applicable to male contacts.

4.3.5 Mating and Unmating Forces

The forces applied for the mating and unmating of the connectors shall conform to the values specified in Table 1(c).

4.3.6 Insert Retention (In Shell)

Not applicable.

4.3.7 Jackscrew Retention

Not applicable.

4.3.8 Contact Insertion and Withdrawal Forces

Not applicable.

4.3.9 Engagement and Separation Forces (Male Contacts)

The contact engagement and separation forces of the male contacts shall be tested to a depth of 1.5mm with the applicable test gauge fixture specified in Figure 3 of this specification, and shall not exceed the values of the table hereunder.

MEASUREMENTS	INNER DIAMETER (mm)		SEPARATION FORCE Min. (N)	ENGAGEMENT FORCE Max. (N)
	Min.	Max.		
Max. Gauge Fixture	0.559	0.564	-	1.667
Min. Gauge Fixture	0.582	0.587	0.137	-

4.3.10 Oversize Pin Exclusion

Not applicable.

4.3.11 Probe Damage

Not applicable.

4.3.12 Solderability

Not applicable.

4.3.13 Latching

Unlocking is achieved by applying a force of 3N minimum, perpendicular to the connector at the end of the spring.

The endurance test (10 cycles of mating/unmating) shall be performed with the force, applied at the end of the spring, necessary to achieve a travel of 1mm (unlocking travel = 0.5mm, total travel = 1.15mm). The requirement after the endurance test is that dimension d = 0.05mm, minimum.

4.4 MATERIALS AND FINISHES

The materials and finishes shall be as specified herein. Where a definite material is not specified, a material which will enable the connectors specified herein to meet the performance requirements of this specification shall be used. Acceptance or approval of any constituent material does not guarantee acceptance of the finished product.

4.4.1 Inserts

Inserts shall be made of glass fibre-filled diallylphthalate resin or suitable thermoplastic material.

4.4.2 Contacts

4.4.2.1 Female Contacts

The contact body shall be made of copper alloy with an underplate of 1.0 μ m minimum of copper to MIL-C-14550, gold plated with 1.27 μ m minimum of gold, Type 2, Grade C of MIL-G-45204. Measurement of thickness shall be performed at a distance of 1.5mm from the engagement end.

4.4.2.2 Male Contacts

The contact body and the bundle shall be made of copper alloy with an underplate of 1.0 μ m minimum of copper to MIL-C-14550, gold plated with 1.27 μ m minimum of gold, Type 2, Grade C of MIL-G-45204. Measurement of thickness shall be performed at a distance of 1.5mm from the engagement end.

4.4.3 Guide Posts

Guide posts shall be made from passivated stainless steel, Type 303.

4.4.4 Latching

Clip and spring shall be made of passivated stainless steel.

4.4.5 Insulated Wires

Wire materials and finishes shall be in accordance with the requirements specified in Para. 4.4 of ESCC Detail Specification No. 3901/013.

4.4.6 Uninsulated Solid Wires

Uninsulated solid wires shall be made of copper alloy in accordance with Type 'S' as specified in QQ-W-343. They shall be gold-plated in accordance with Class $\Phi\Phi$, Grade C or D, as specified in MIL-G-45204.

4.4.7 Rear Potting

Rear potting shall be made of epoxy resin.

4.5 MARKING

4.5.1 General

The marking of all components delivered to this specification shall be in accordance with the requirements of ESCC Basic Specification No. 21700 and the following paragraphs.

When the component is too small to accommodate all of the marking specified, as much as space permits shall be marked and the marking information, in full, shall accompany the component in its primary package.

The information to be marked and the order of precedence shall be as follows:-

- (a) The ESCC Component Number.
- (b) Characteristics.
- (c) Traceability Information.



4.5.2 Contact Identification

Not applicable.

4.5.3 The ESCC Component Number

The ESCC Component Number shall be constituted and marked as follows:

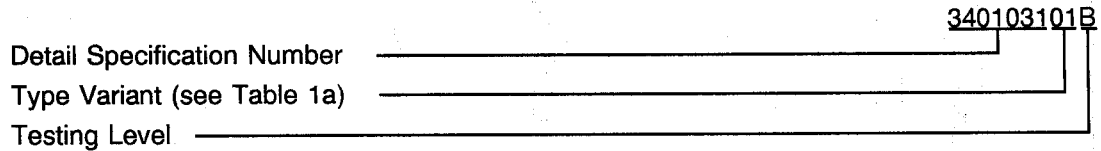

4.5.4 Characteristics

The characteristics to be marked in the following order of precedence are:-

- (a) Shell Size.
- (b) Contact Type.
- (c) Termination Type.
- (d) Polarisation (optional).

The information shall be constituted and marked as follows:-

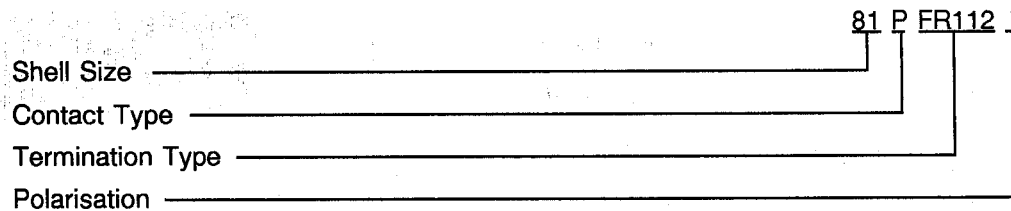

4.5.4.1 Shell Size

The shell size shall be designated by 2 digits representing the number of available cavities plus 4 additional cavities plus (see Para. 1.2):-

- (a) 4 additional cavities for Variant 01 - The specified numbers range from 05 through to 87 maximum.
- (b) 5 additional cavities for Variant 02 - The specified numbers range from 06 through to 87 maximum.

4.5.4.2 Contact Types

Contact types shall be indicated by the following code letters.

Code Letter	Contact Type
P	Male
S	Female

4.5.4.3 Termination Types

Termination types define length of insulated wire or uninsulated solid wire according to Figures 2.2 and 2.3 as follows.

Code	Type (see Figure 2)	Min. Length (mm)
FR 112	Wire AWG 26	508
FR 113	Wire AWG 26	914
FR 114	Wire AWG 28	508
FR 115	Wire AWG 28	918
FR 116	Uninsulated Solid Wire	25
FR 116 C	Uninsulated Solid 90°C Formed Wire	4
FR 116 D1	Uninsulated Solid 90°C Formed Wire (Long Terminations on Odd Contacts)	4
FR 116 D2	Uninsulated Solid 90°C Formed Wire (Long Terminations on Even Contacts)	4

4.5.4.4 Polarisation

The marking of the cavity number used for the polarisation is optional and is used only in case the Orderer wishes to specify his own polarisation means by epoxy-filled cavities or guide posts (see Para. 1.2). There is no mandatory requirement for this part of the marking.

4.5.5 Traceability Information

Traceability information shall be marked in accordance with the requirements of ESCC Basic Specification No. 21700.

4.6 ELECTRICAL MEASUREMENTS

4.6.1 Electrical Measurements at Room Temperature

The parameters to be measured in respect of electrical characteristics are scheduled in Table 2. Unless otherwise specified, the measurements shall be performed at $T_{amb} = +22 \pm 3^{\circ}\text{C}$.

4.6.2 Electrical Measurements at High and Low Temperatures

Not applicable.

4.6.3 Circuits for Electrical Measurements (Figure 4)

Not applicable

4.7 BURN IN AND ELECTRICAL MEASUREMENTS

Not applicable.



TABLE 2 - ELECTRICAL MEASUREMENTS AT ROOM TEMPERATURE

No.	CHARACTERISTICS	SYMBOL	ESCC 3401 TEST METHOD	TEST CONDITIONS	LIMITS		UNIT
					MIN.	MAX.	
1	Insulation Resistance	Ri	Para. 9.1.1.1	Para. 9.1.1.1	5000	-	MΩ
2	Voltage Proof Leakage Current	I _L	Para. 9.1.1.2	600 Vrms	-	2.0	mA
3	Mated Shell Conductivity (Voltage Drop) (1)	Vd	Para. 9.1.1.4	Para. 9.1.1.4	Not applicable		mV
4	Contact Resistance (Low Level Current)	Rcl max.	Para. 9.1.1.3	Para. 9.1.1.3	-	6.0	mΩ
5	Contact Resistance (Rated Current)	Rcr max.	Para. 9.1.1.3	Table 1(d)	-	5.0	mΩ

NOTES

1. Applicable to mated connectors with grounding option.

TABLES 3, 4 AND 5

Not applicable.

FIGURE 3 - GAUGE FIXTURE

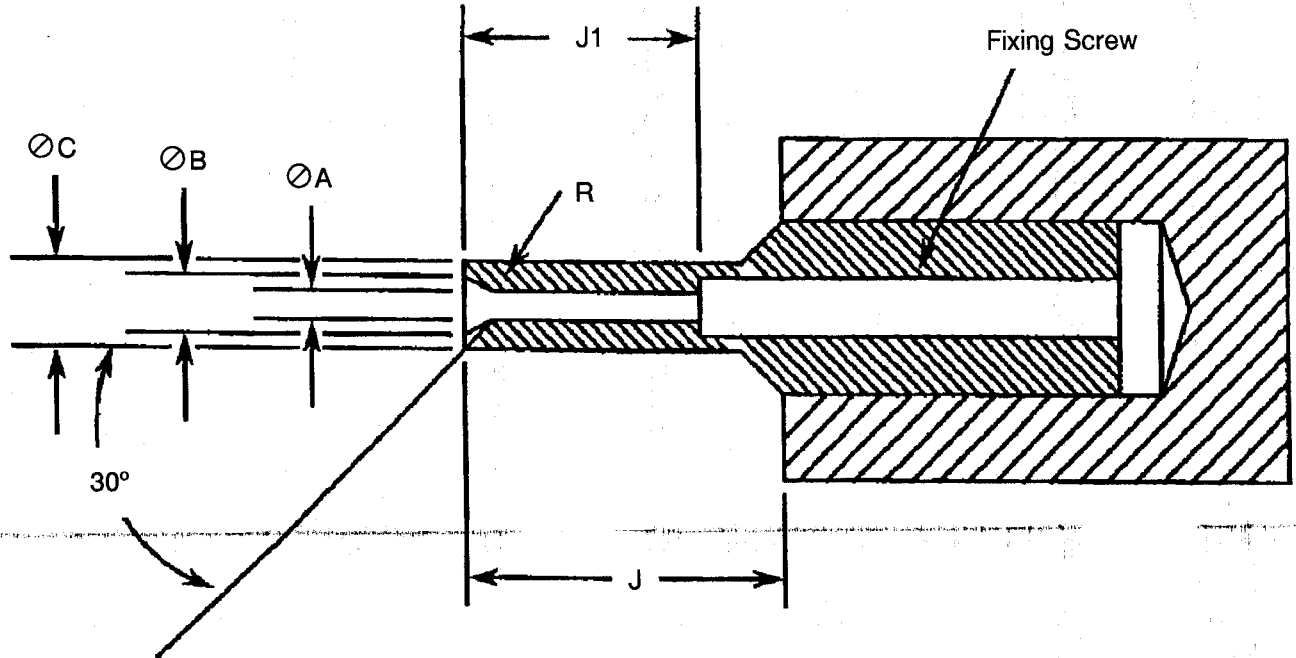

MAXIMUM GAUGE

WEIGHT (g) 170			REMARKS
	MIN.	MAX.	
ØA	0.559	0.564	-
ØB	0.749	0.775	-
ØC	0.813	0.825	-
J	4.0	-	-
J1	3.13	3.23	-
R	0.381	0.483	Note 1

MINIMUM GAUGE

WEIGHT (g) 14			REMARKS
	MIN.	MAX.	
ØA	0.582	0.587	-
ØB	0.749	0.775	-
ØC	0.813	0.825	-
J	4.0	-	-
J1	3.13	3.23	-
R	0.381	0.483	Note 1

NOTES

1. Radius "R" must be tangent to entry chamfer and ØA.
2. ØA and entry chamfer must be polished to ∇_{NB} .

- 4.8 ENVIRONMENTAL AND ENDURANCE TESTS (CHARTS IV AND V OF ESCC GENERIC SPECIFICATION NO. 3401)
- 4.8.1 Measurements and Inspections on Completion of Environmental Tests
The parameters to be measured and inspections to be performed on completion of environmental tests shall be those scheduled in Table 6. Unless otherwise stated, the measurements shall be performed at $T_{amb} = +22 \pm 3$ °C.
- 4.8.2 Measurements and Inspections at Intermediate Points during Endurance Tests
Not applicable.
- 4.8.3 Measurements and Inspections on Completion of Endurance Tests
The parameters to be measured and inspections to be performed on completion of endurance tests shall be those scheduled in Table 6. Unless otherwise stated, the measurements shall be performed at $T_{amb} = +22 \pm 3$ °C.
- 4.8.4 Conditions for Operating Life Tests (Part of Endurance Testing)
Not applicable.
- 4.8.5 Electrical Circuits for Operating Life Tests (Figure 5)
Not applicable.
- 4.8.6 Conditions for High Temperature Storage Test (Part of Endurance Testing)
The requirements for the high temperature storage test are specified in Section 9 of ESCC Generic Specification No. 3401. The temperature to be applied shall be the maximum storage temperature specified in Table 1(b) of this specification.



TABLE 6 - MEASUREMENTS AND INSPECTIONS ON COMPLETION OF ENVIRONMENTAL AND ENDURANCE TESTS

NO.	ESCC GENERIC SPEC. NO. 3401		MEASUREMENTS AND INSPECTIONS		SYMBOL	LIMITS		UNIT
	ENVIRONMENTAL AND ENDURANCE TESTS (1)	TEST METHOD AND CONDITIONS	IDENTIFICATION	CONDITIONS		MIN.	MAX.	
01	Seal Test	Para. 9.9	ESCC 3401 Para. 9.9	-	-	Not applicable		-
02	Wiring	Para. 9.10 and Table 1(d) of this specification	Low Level Contact Resistance	Table 2 Item 4	Rcl	Table 2, Item 4		-
03	Vibration	Para. 9.11	Final Measurements Full Engagement Visual Examination		- -	- -	- -	- -
04	Shock or Bump	Para. 9.12	Full Engagement Visual Examination		- -	- -	- -	- -
05	Climatic Sequence	Para. 9.13	Dry Heat Insulation Resistance	At High Temperature Table 2, Item 1	Ri	10	-	MΩ
			Low Air Pressure Voltage Proof Leakage Current	Figure 1	I _L	ESCC 3401 Para. 9.13.5		-
			Damp Heat Insulation Resistance	Immediately after test Table 2, Item 1	Ri	100	-	MΩ
			Final Measurements External Visual Inspection Insulation Resistance Voltage Proof Leakage Current	After 1-24 hrs Recovery ESCC 3401 Para. 9.7 Table 2, Item 1 Table 2, Item 2	- Ri I _L	ESCC 3401 Para. 9.7 Table 2, Item 1 Table 2, Item 2		-
06	Plating Thickness	Para. 9.14	Thickness		-	Para 4.4.2 of this spec.		-
07	Joint Strength (N/A to solder contacts)	Para. 9.15	ESCC 3401 Para. 9.15		-	Not applicable		
08	Rapid Change of Temperature	Para. 9.16	Visual Examination Insulation Resistance Voltage Proof Leakage Current	Table 2, Item 1 Table 2, Item 2	- Ri I _L	- -	- -	- -
09	Contact Retention (In Insert)	Para. 9.17 and Para. 4.3.4 of this spec.	Contact Displacement	Not applicable for male contacts	-	ESCC 3401 Para. 9.17		-

NOTES

1. The tests in this Table refer to either Chart IV or V and shall be used as applicable.



TABLE 6 - MEASUREMENTS AND INSPECTIONS ON COMPLETION OF ENVIRONMENTAL AND ENDURANCE TESTS (CONTINUED)

NO.	ESCC GENERIC SPEC. NO. 3401		MEASUREMENTS AND INSPECTIONS		SYMBOL	LIMITS		UNIT
	ENVIRONMENTAL AND ENDURANCE TESTS (1)	TEST METHOD AND CONDITIONS	IDENTIFICATION	CONDITIONS		MIN.	MAX.	
10	Endurance	Para. 9.18	Initial Measurements Mating/Unmating Forces Low Level Contact Resistance Mated Shell Conductivity Final Measurements Visual Examination Mating/Unmating Forces Low Level Contact Drift Resistance Mated Shell Conductivity Insulation Resistance Voltage Proof Leakage Current	Table 2, Item 4 Table 2, Item 3 - Table 2, Item 4 Table 2, Item 5 Table 2, Item 3 Table 2, Item 1 Table 2, Item 2	F Rcl Vd - F ΔRcl Vd Ri I _L	Para 4.3.5 of this spec. Record Values Not applicable - Para. 4.3.5 of this spec. - 3.0 Not applicable Table 2, Item 1 Table 2, Item 2	mΩ	
11	Permanence of Marking	Para. 9.19	-	-	-	-	-	-
12	Mating/Unmating Forces	Para. 9.20	Force	-	F	Para 4.3.5 of this spec.		
13	High Temperature Storage	Para. 9.21	Initial Measurements Low Level Contact Resistance Mated Shell Conductivity Final Measurements Visual Examination Mating/Unmating Forces Low Level Contact Drift Resistance Rated Current Contact Resistance Mated Shell Conductivity Insulation Resistance Voltage Proof Leakage Current Contact Retention (In Insert)	Table 2, Item 4 - - Table 2, Item 4 Table 2, Item 5 Table 2, Item 3 Table 2, Item 1 Table 2, Item 2 Para. 4.3.4 of this spec.	Rcl Vd - F ΔRcl Rcr Vd Ri I _L	Record Values Not applicable - Para. 4.3.5 of this spec. - 3.0 Table 2, Item 5 Not applicable Table 2, Item 1 Table 2, Item 2 ESCC 3401 Para. 9.17	mΩ	
14	Corrosion	Para. 9.22	Visual Examination	-	-	-	-	-
15	Insert Retention (In Shell)	Para. 9.23 and Para. 4.3.6 of this spec.	Visual Examination	-	-	Not applicable		
16	Jackscrew Retention	Para. 9.24 and Para. 4.3.7 of this spec.	Visual Examination	-	-	Not applicable		

NOTES

1. The tests in this Table refer to either Chart IV or V and shall be used as applicable.



TABLE 6 - MEASUREMENTS AND INSPECTIONS ON COMPLETION OF ENVIRONMENTAL AND ENDURANCE TESTS (CONTINUED)

NO.	ESCC GENERIC SPEC. NO. 3401		MEASUREMENTS AND INSPECTIONS		SYMBOL	LIMITS		UNIT
	ENVIRONMENTAL AND ENDURANCE TESTS (1)	TEST METHOD AND CONDITIONS	IDENTIFICATION	CONDITIONS		MIN.	MAX.	
17	High Temperature Measurements	Para. 9.25	Insulation Resistance	Table 2, Item 1	Ri	5000	-	MΩ
18	Overload Test	Para. 9.26	Internal Temperature	-	T	-	+ 100	°C
			Rated Current Contact Resistance	Table 2, Item 5	Rcr	Table 2, Item 5		
			Mated Shell Conductivity	Table 2, Item 3	Vd	Not applicable		
			Insulation Resistance	Table 2, Item 1	Ri	Table 2, Item 1		
19	Maintenance Ageing	Para. 9.27 and Paras. 4.2.4 and 4.2.5 of this spec.	Visual Examination	-	-	Not applicable		
			Contact Retention (In Insert)	-	-	Not applicable		
20	Engagement/Separation Forces	Para. 9.28 and Para. 4.3.9 of this spec.	Force		F	Para. 4.3.9 of this spec.		
21	Oversize Pin Exclusion	Para. 9.29 and Para. 4.3.10 of this spec.	-	-	-	Not applicable		
22	Probe Damage	Para. 9.30 and Para. 4.3.11 of this spec.	Contact Separation Force	-	-	Not applicable		
23	Solderability	Para. 9.31 and Para. 4.3.12 of this spec.	-	-	-	Not applicable		

NOTES

1. The tests in this Table refer to either Chart IV or V and shall be used as applicable.



APPENDIX 'A'

AGREED DEVIATIONS FOR C&K COMPONENTS (F)

ITEMS AFFECTED	DESCRIPTION OF DEVIATION
Para. 4.2.2, Deviations from Final Production Tests (Chart II)	Para. 9.4, Contact Capability: 100% Contact Capability Test may be omitted provided that a 100% visual inspection of the contacts is performed on each batch submitted to tests defined in the C&K PID requirements.