



Pages 1 to 21

**CONNECTOR SAVERS, ELECTRICAL, RECTANGULAR,
MICROMINIATURE,
BASED ON TYPE MDM**

ESCC Detail Specification No. 3401/041

Issue 4	February 2010
---------	---------------



Document Custodian: European Space Agency - see <https://escies.org>

LEGAL DISCLAIMER AND COPYRIGHT

European Space Agency, Copyright © 2010. All rights reserved.

The European Space Agency disclaims any liability or responsibility, to any person or entity, with respect to any loss or damage caused, or alleged to be caused, directly or indirectly by the use and application of this ESCC publication.

This publication, without the prior permission of the European Space Agency and provided that it is not used for a commercial purpose, may be:

- copied in whole, in any medium, without alteration or modification.
- copied in part, in any medium, provided that the ESCC document identification, comprising the ESCC symbol, document number and document issue, is removed.

DOCUMENTATION CHANGE NOTICE

(Refer to <https://escies.org> for ESCC DCR content)

DCR No.	CHANGE DESCRIPTION
560, 561	Specification upissued to incorporate editorial changes per DCR.

TABLE OF CONTENTS

1.	<u>GENERAL</u>	<u>6</u>
1.1	Scope	6
1.2	Type Variants	6
1.3	Maximum Ratings	6
1.4	Parameter Derating Information	6
1.5	Physical Dimensions	6
1.6	Contact Arrangements	6
2.	<u>APPLICABLE DOCUMENTS</u>	<u>6</u>
3.	<u>TERMS, DEFINITIONS, ABBREVIATIONS, SYMBOLS AND UNITS</u>	<u>7</u>
4.	<u>REQUIREMENTS</u>	<u>11</u>
4.1	General	11
4.2	Deviations from Generic Specification	12
4.2.1	Deviations from Special In-Process Controls	12
4.2.2	Deviations from Final Production Tests (Chart II)	12
4.2.3	Deviations from Burn-in and Electrical Measurements (Chart III)	12
4.2.4	Deviations from Qualification Tests (Chart IV)	12
4.2.5	Deviations from Lot Acceptance Tests (Chart V)	12
4.3	Mechanical Requirements	12
4.3.1	Dimension Check	12
4.3.2	Weight	13
4.3.3	Contact Capability	13
4.3.4	Contact Retention (in Insert)	13
4.3.5	Mating and Unmating Forces	13
4.3.6	Insert Retention (in Shell)	13
4.3.7	Jackscrew Retention	13
4.3.8	Contact Insertion and Withdrawal Forces	13
4.3.9	Engagement and Separation Forces (Male Contacts)	13
4.3.10	Oversize Pin Exclusion	14
4.3.11	Probe Damage	14
4.3.12	Solderability	14
4.4	Materials and Finishes	14
4.4.1	Shells	14
4.4.2	Inserts	14
4.4.3	Contacts	14
4.4.3.1	Female Contacts	14
4.4.3.2	Male Contacts	14
4.4.4	Seals Interfacial	14
4.4.5	Uninsulated Solid Wire	14
4.4.6	Potting	15
4.5	Marking	15
4.5.1	General	15
4.5.2	The ESCC Component Number	15
4.5.3	Characteristics	15
4.5.3.1	Shell Size	15
4.5.3.2	Type of Contact	15
4.5.4	Traceability Information	16
4.6	Electrical Measurements	16
4.6.1	Electrical Measurements at Room Temperature	16
4.6.2	Electrical Measurements at High and Low Temperatures (Table 3)	16
4.6.3	Circuits for Electrical Measurements (Figure 4)	16

4.7	Burn-in and Electrical Measurements (Tables 4 and 5)	16
4.8	Environmental and Endurance Tests (Charts IV and V of ESCC Generic Specification No. 3401)	18
4.8.1	Measurements and Inspections on Completion of Environmental Tests	18
4.8.2	Measurements and Inspections at Intermediate Points during Endurance Tests	18
4.8.3	Measurements and Inspections on Completion of Endurance Tests	18
4.8.4	Conditions for Operating Life Test (Part of Endurance Testing)	18
4.8.5	Electrical Circuit for Operating Life Test (Figure 5)	18
4.8.6	Conditions for High Temperature Storage Test (Part of Endurance Testing)	18
APPENDIX 'A' - AGREED DEVIATIONS FOR C & K COMPONENTS (F)		21

1. GENERAL

1.1 SCOPE

This specification details the ratings, physical and electrical characteristics, test and inspection data for Connector Savers, Electrical, Rectangular, Microminiature with Non-removable Crimp-type Contacts, based on type MDM.

It shall be read in conjunction with:

- (a) ESCC Generic Specification No. 3401, Connectors, Electrical, Non-Filtered, Circular and Rectangular.
- (b) ESCC Detail Specification No. 3401/032, Accessories for Connectors, Microminiature, 3401/029, 3401/077 and Connector Savers 3401/041.

the requirements of which are supplemented herein.

1.2 TYPE VARIANTS

Variants of the basic type connector savers specified herein, which are also covered by this specification, together with their mechanical characteristics, are given in Table 1(a).

1.3 MAXIMUM RATINGS

The maximum ratings, which shall not be exceeded at any time during use or storage, applicable to the connector savers specified herein, are scheduled in Table 1(b).

1.4 PARAMETER DERATING INFORMATION

The derating information applicable to the connector savers specified herein is shown in Figure 1.

1.5 PHYSICAL DIMENSIONS

The physical dimensions of the connector savers specified herein are shown in Figure 2.

1.6 CONTACT ARRANGEMENTS

Contact arrangements are shown in Figure 3.

2. APPLICABLE DOCUMENTS

The following documents form part of this specification and shall be read in conjunction with it:

- (a) ESCC Generic Specification No. 3401, Connectors, Electrical, Non-Filtered, Circular and Rectangular.
- (b) ESCC Detail Specification No. 3401/032, Accessories for Connectors, Microminiature, 3401/029, 3401/077 and Connector Savers 3401/041.
- (c) A-A-59551, Wire, Electrical, Copper, Uninsulated.
- (d) MIL-DTL-45204, Gold Plating, Electro-deposited.
- (e) MIL-DTL-14550, Copper Plating, Electro-deposited.
- (f) MIL-DTL-83513, Connectors, Electrical, Rectangular, Microminiature, Polarised Shell, Generic Specification for.

3. TERMS, DEFINITIONS, ABBREVIATIONS, SYMBOLS AND UNITS

For the purpose of this specification, the terms, definitions, abbreviations, symbols and units specified in ESCC Basic Specification No. 21300 shall apply.

TABLE 1(a) - TYPE VARIANTS

Variant	Shell Size Notes 1, 2	Max. Weight (g) Note 3	Max. Mating Force (N)	Unmating Force (N)	
				Max.	Min.
01	9	4	20	20	1.3
02	15	5.5	33	33	2
03	21	7	47	47	2.9
04	25	8	55	55	3.5
05	31	9.5	69	69	4.3
06	37	10	82	82	5.1
07	51	13.5	113	113	7.1

NOTES:

1. Contacts are fixed in the connector saver.
2. Shell Size 51 is not applicable to MDMA connectors.
3. Connector saver with contacts and without screw-locks.

TABLE 1(b) - MAXIMUM RATINGS

No.	Characteristics	Symbol	Maximum Rating	Unit	Remarks
1	Working Voltage (Sea Level)	U_R	150	Vrms	Note 1
2	Rated Current: (uninsulated solid wire)	I_R	2.5	A	Note 2
3	Operating Temperature Range	T_{op}	-55 to +125	°C	
4	Storage Temperature Range	T_{stg}	-55 to +125	°C	

NOTES:

1. Between contacts, and contact and shell.
2. I_R requires derating if the number of current-carrying contacts in the connector saver is 2 or greater. See Figure 1(b).

FIGURE 1 - PARAMETER DERATING INFORMATION

FIGURE 1(a) - Working Voltage Versus Altitude

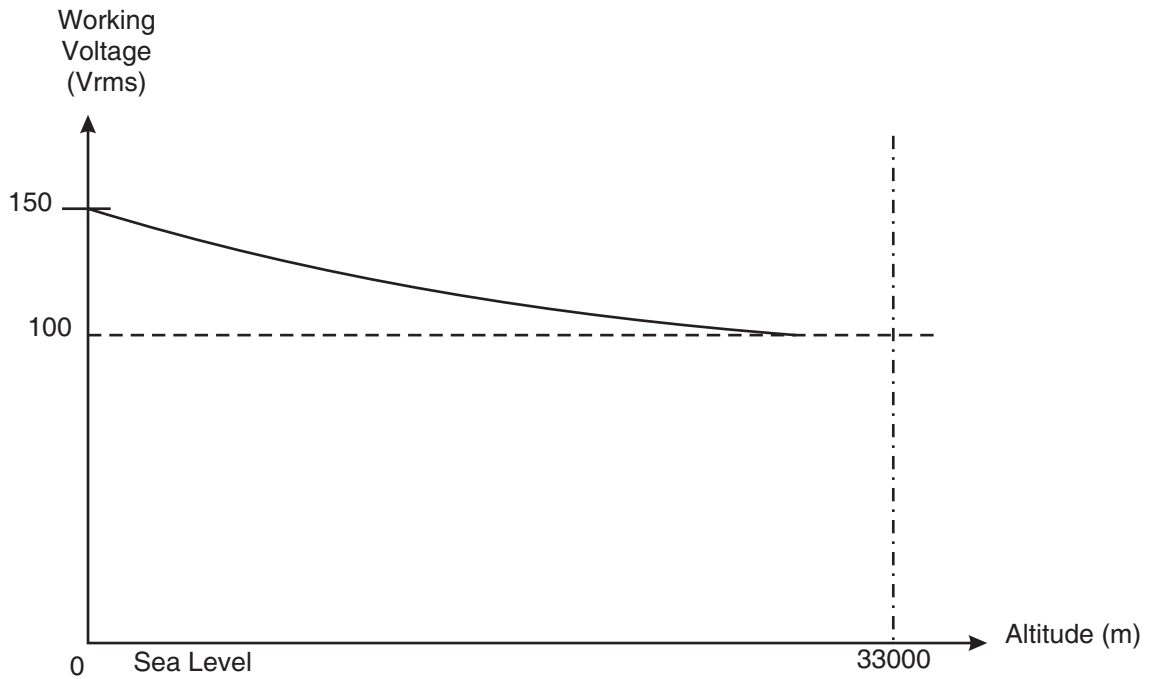
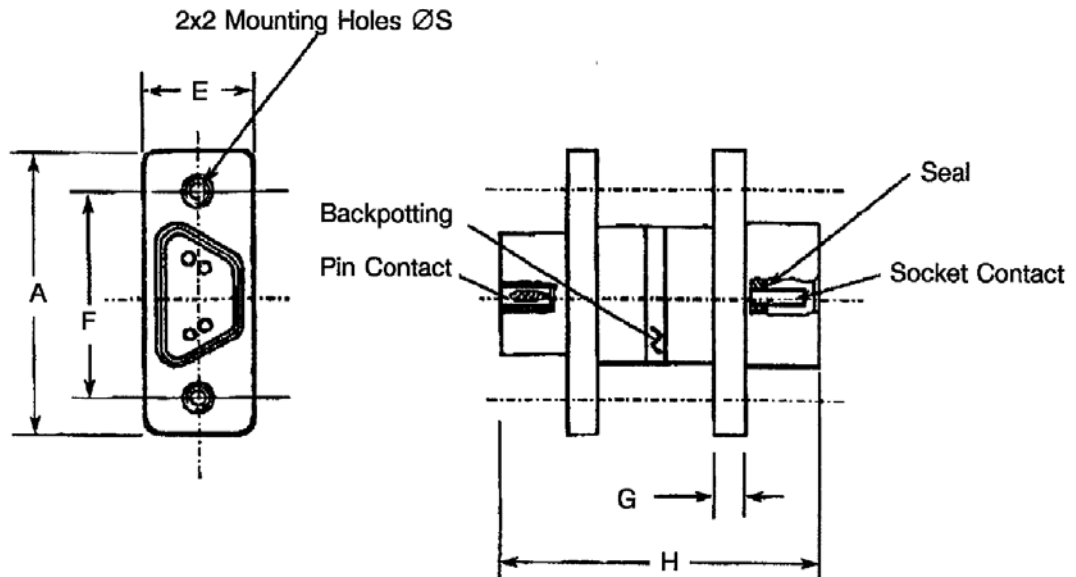

FIGURE 1(b) - Maximum Current Versus Number Of Contacts

Number of Current-Carrying Contacts per Connector Saver	Maximum Current per Contact (A)
	Uninsulated Solid Wire
2 - 4	2
5 - 14	1.8
15 and over	1.4

FIGURE 2 - PHYSICAL DIMENSIONS
FIGURE 2.1 - CONNECTOR SAVER DIMENSIONS



Variant	Size	A	E	F	G	H	$\varnothing S$	
		Max.	Max.	Max.	Typical	Typical	Min.	Max.
01	09	19.94	7.75	14.35	2.29	22.86	2.23	2.39
02	15	23.75	7.75	18.16	2.29	22.86	2.23	2.39
03	21	27.56	7.75	21.97	2.29	22.86	2.23	2.39
04	25	30.1	7.75	24.51	2.29	22.86	2.23	2.39
05	31	33.91	7.75	28.32	2.29	22.86	2.23	2.39
06	37	37.72	7.75	32.13	2.29	22.86	2.23	2.39
07	51	36.45	7.75	30.86	2.29	22.86	2.23	2.39

NOTES:

- All dimensions are in millimetres.

FIGURE 2.2 - CONTACT POSITION
Figure 2.2.1 - Mounting Condition

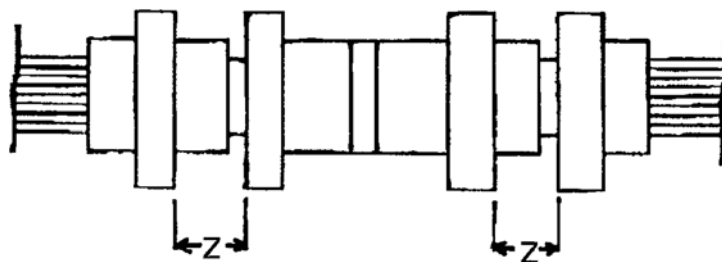

FIGURE 2.2.2 - Plug Male Contact

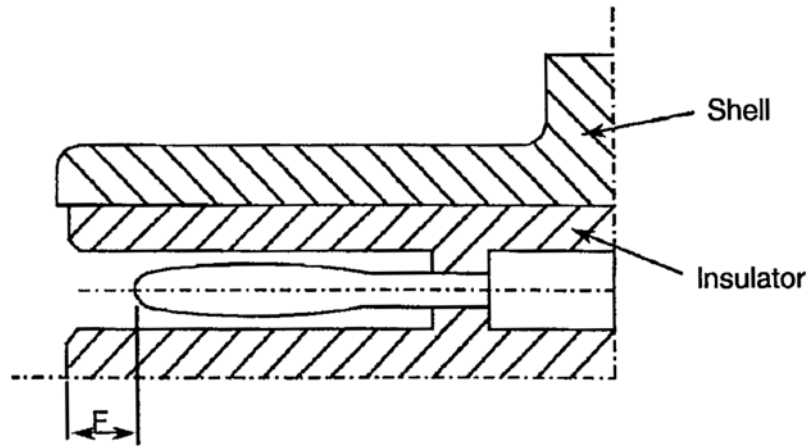
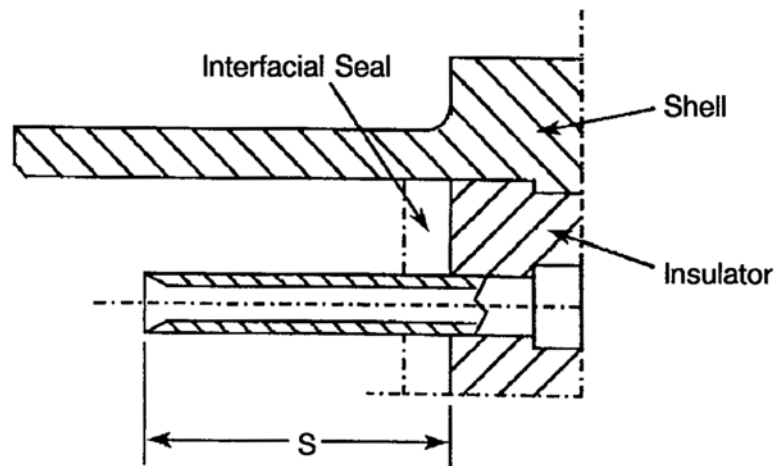

FIGURE 2.2.3 - Receptacle Female Contact



F		S		Z
Min.	Max.	Min.	Max.	Max.
0.25	0.91	3.3	3.66	5.49

NOTES:

1. All dimensions are in millimetres.

FIGURE 3 - CONTACT ARRANGEMENTS
FRONT VIEW OF MALE INSERT - USE MIRROR VIEW FOR FEMALE INSERT

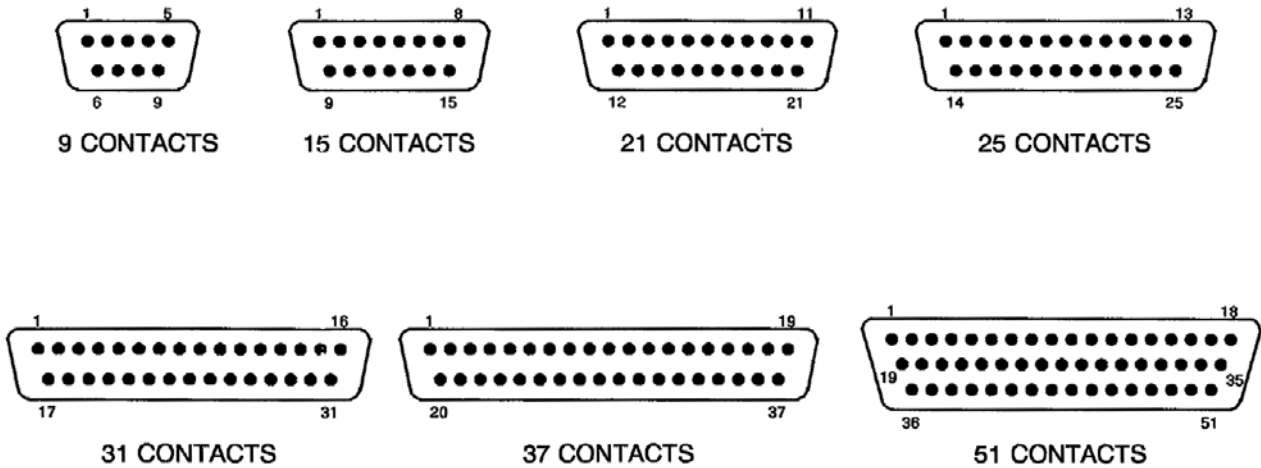

NOTES:

1. Only the outside contact cavities on each row are identified in the drawing, the remainder follow sequentially. Contact numbers are shown outside the insert for readability.

Contact Centres

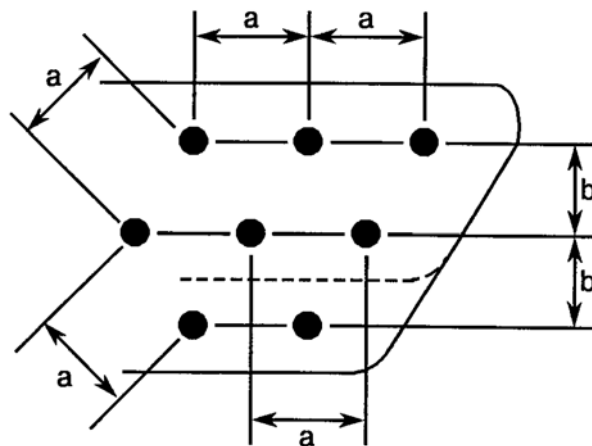

NOTES:

1. a = Distance between contact centres: 1.27mm typical.
2. b = Distance between rows: 1.09mm typical.

4. REQUIREMENTS

4.1 GENERAL

The complete requirements for procurement of the connector savers specified herein are stated in this specification and ESCC Generic Specification No. 3401. Deviations from the Generic Specification, applicable to this specification only, are listed in Para. 4.2.

Deviations from the applicable Generic Specification and this Detail Specification, formally agreed with

specific Manufacturers on the basis that the alternative requirements are equivalent to the ESCC requirements and do not affect the components' reliability, are listed in the appendices attached to this specification.

4.2 DEVIATIONS FROM GENERIC SPECIFICATION

4.2.1 Deviations from Special In-Process Controls

Para. 9.15, Joint Strength: The contacts shall be crimped to uninsulated solid wire AWG25. The value of failure shall be recorded together with the information to whether the failure was "pull-out", "break in crimp" or "break in wire". The minimum tensile strength shall be as follows:

Wire	Male and Female Contacts
	AWG25 - Solid Uninsulated
Tensile Strength (N)	22

4.2.2 Deviations from Final Production Tests (Chart II)

- (a) Para. 9.3, Contact Retainer Test: Not applicable.
- (b) Para. 9.4, Contact Capability: This test shall be performed on the male contacts. For details see Para. 4.3.3 of this specification.
- (c) Para. 9.5, Magnetism Level: Not applicable.

4.2.3 Deviations from Burn-in and Electrical Measurements (Chart III)

Chart III is not applicable.

4.2.4 Deviations from Qualification Tests (Chart IV)

- (a) Para. 9.9, Seal Test: Not applicable.
- (b) Para. 9.15, Joint Strength: Not applicable.
- (c) Para. 9.17, Contact Retention (in insert): Not applicable with male contact.
- (d) Para. 9.27, Maintenance Ageing: Not applicable.
- (e) Para. 9.29, Oversize Pin Exclusion: Not applicable.
- (f) Para. 9.30, Probe Damage: Not applicable.

4.2.5 Deviations from Lot Acceptance Tests (Chart V)

- (a) Para. 9.9, Seal Test: Not applicable.
- (b) Para. 9.15, Joint Strength: Not applicable.
- (c) Para. 9.17, Contact Retention (in insert): Not applicable with male contact.
- (d) Para. 9.27, Maintenance Ageing: Not applicable.
- (e) Para. 9.29, Oversize Pin Exclusion: Not applicable.
- (f) Para. 9.30, Probe Damage: Not applicable.

4.3 MECHANICAL REQUIREMENTS

4.3.1 Dimension Check

The dimensions of the connector savers specified herein shall be verified in accordance with the

requirements set out in Para. 9.6 of ESCC Generic Specification No. 3401 and shall conform to those shown in Figure 2 of this specification. Only the underlined dimensions shall be checked during procurement.

4.3.2 Weight

The maximum weight of the connector savers specified herein shall be as specified in Table 1(a).

4.3.3 Contact Capability

For the purpose of this test, the pick-up and drop weights shall be as follows.

Measurements	Pick-up Weight	Drop Weight
Weight (g)	14	170
Inner Gauge Diameter (mm) (1)	0.582 - 0.587	0.559 - 0.564
Insertion Depth (mm)	1.5	1.5

NOTES:

1. See Figure 4 for ØA.

4.3.4 Contact Retention (in Insert)

Contact retention within the insert shall be 22.25 Newtons. There shall be no displacement of the contact. Not applicable to male contacts.

4.3.5 Mating and Unmating Forces

The forces applied for the mating and unmating of the connector savers shall conform to the values specified in Table 1(a).

4.3.6 Insert Retention (in Shell)

Connector saver inserts shall withstand a pressure of 34.4N/cm² applied from the mating side to the rear side.

4.3.7 Jackscrew Retention

Not applicable.

4.3.8 Contact Insertion and Withdrawal Forces

Not applicable.

4.3.9 Engagement and Separation Forces (Male Contacts)

The contact engagement and separation forces of the male contacts shall be tested to a depth of 1.5mm with the applicable test gauge fixtures specified in Figure 4 of this specification, and shall not exceed the values of the table hereunder.

Measurements	Inner Diameter (mm)		Separation Force Min. (N)	Engagement Force Max. (N)
	Min.	Max.		
Max. Gauge Fixture	0.559	0.564	-	1.667

Measurements	Inner Diameter (mm)		Separation Force Min. (N)	Engagement Force Max. (N)
	Min.	Max.		
Min. Gauge Fixture	0.582	0.587	0.137	-

4.3.10 Oversize Pin Exclusion
Not applicable.

4.3.11 Probe Damage
Not applicable.

4.3.12 Solderability
Not applicable.

4.4 MATERIALS AND FINISHES

The materials and finishes shall be as specified herein. Where a definite material is not specified, a material which will enable the components specified herein to meet the performance requirements of this specification shall be used. Acceptance or approval of any constituent material does not guarantee acceptance of the finished product.

4.4.1 Shells
Shells shall be made of aluminium alloy plated with a minimum thickness of 25.4µm of electroless nickel.

4.4.2 Inserts
Inserts shall be made of glass-fibre filled diallylphthalate resin or a suitable thermoplastic material.

4.4.3 Contacts

4.4.3.1 *Female Contacts*

The contact body shall be made of copper alloy with an underplate of 1µm minimum of copper to MIL-C-14550, gold plated with 1.27µm minimum of gold, Type 2, Grade C of MIL-DTL-45204. Measurement of thickness shall be performed at a distance of 1.5mm from the engagement end.

4.4.3.2 *Male Contacts*

The contact body and the bundle shall be made of copper alloy with an underplate of 1µm minimum of copper to MIL-C-14550, gold plated with 1.27µm minimum of gold, Type 2 Grade C of MIL-DTL-45204. Measurement of thickness shall be performed at a distance of 1.5mm from the engagement end.

4.4.4 Seals Interfacial
Interfacial seals shall be made of silicon base rubber.

4.4.5 Uninsulated Solid Wire
Uninsulated solid wires shall be made of copper alloy in accordance with Type S as specified in A-A-59551. They shall be gold-plated in accordance with Class 00, Grade C or D, as specified in MIL-DTL-45204.

4.4.6 Potting

Potting shall be made of epoxy resin.

4.5 MARKING

4.5.1 General

The marking of components delivered to this specification shall be in accordance with the requirements of ESCC Basic Specification No. 21700 and the following paragraphs. When the component is too small to accommodate all of the marking specified, as much as space permits shall be marked and the marking information, in full, shall accompany the component in its primary package.

The information to be marked and the order of precedence shall be as follows:

- (a) The ESCC Component Number.
- (b) Characteristics.
- (c) Traceability Information.

4.5.2 The ESCC Component Number

Each component shall bear the ESCC Component Number which shall be constituted and marked as follows:

340104101B

- Detail Specification Number: 3401041
- Type Variant (See Table 1(a)): 01
- Testing Level: B

4.5.3 Characteristics

The characteristics to be marked in the following order of precedence are:

- (a) Shell Size.
- (b) Type of Contact.

The information shall be constituted and marked as follows (example): 9PS

- Shell size: 9
- Type of Contact: PS

4.5.3.1 *Shell Size*

Shell size shall be designated by the number of contacts.

Specified numbers are: 9, 15, 21, 25, 31, 37 and 51.

4.5.3.2 *Type of Contact*

The contact types shall be indicated by the following code letters.

Code Letter	Contact Type
PS	Male/Female

4.5.4 Traceability Information

Traceability information shall be marked in accordance with the requirements of ESCC Basic Specification No. 21700

4.6 ELECTRICAL MEASUREMENTS

4.6.1 Electrical Measurements at Room Temperature

The parameters to be measured in respect of electrical characteristics are scheduled in Table 2. Unless otherwise specified, the measurement shall be performed at $T_{amb} = +22 \pm 3^{\circ}C$.

4.6.2 Electrical Measurements at High and Low Temperatures (Table 3)

Not applicable.

4.6.3 Circuits for Electrical Measurements (Figure 4)

Not applicable

4.7 BURN-IN AND ELECTRICAL MEASUREMENTS (TABLES 4 AND 5)

Not applicable.

Table 2 - ELECTRICAL MEASUREMENTS AT ROOM TEMPERATURE

No.	Characteristic	Symbol	ESCC 3401 Test Method	Test Condition	Limits		Unit
					Min	Max	
1	Insulation Resistance	R_i	Para. 9.1.1.1	Para. 9.1.1.1	5000	-	$M\Omega$
2	Voltage Proof Leakage Current	I_L	Para. 9.1.1.2	600Vrms	-	2	mA
3	Mated Shell Conductivity (Voltage Drop) Note 1	V_d	Para. 9.1.1.4	Para. 9.1.1.4	Not applicable		mV
4	Contact Resistance Low Level Current	R_{cl}	Para. 9.1.1.3	Para. 9.1.1.3	-	12	$m\Omega$
5	Contact Resistance Rated Current	R_{cr}	Para. 9.1.1.3	Table 1(b)	-	10	$m\Omega$

NOTES:

1. Applicable to mated connectors with grounding option.

TABLES 3, 4 AND 5

Not applicable.

FIGURE 4 - GAUGE FIXTURE

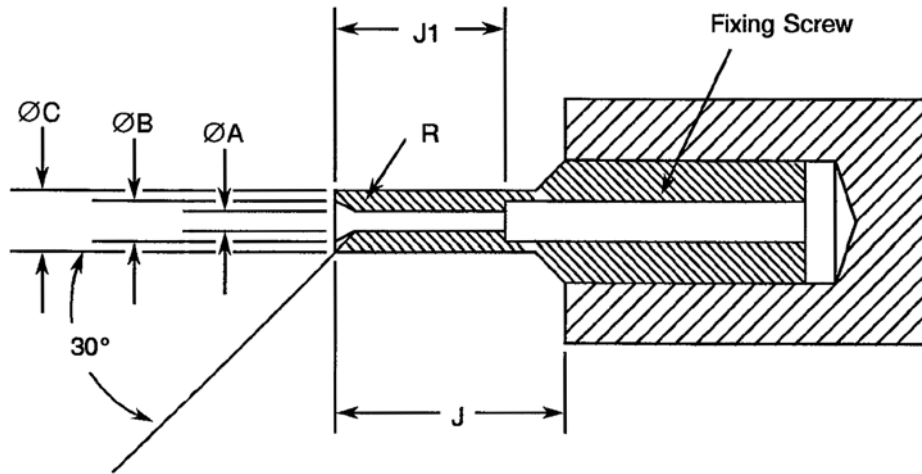

Maximum Gauge

Weight (g) 170			Remarks
	Min.	Max.	
ØA	0.559	0.564	Note 2
ØB	0.749	0.775	-
ØC	0.813	0.825	-
J	4	-	-
J1	3.13	3.23	-
R	0.381	0.483	Note 1

Minimum Gauge

Weight (g) 14			Remarks
	Min.	Max.	
ØA	0.582	0.587	Note 2
ØB	0.749	0.775	-
ØC	0.813	0.825	-
J	4	-	-
J1	3.13	3.23	-
R	0.381	0.483	Note 1

NOTES:

1. Radius R, must be tangent to entry chamfer and ØA.
2. ØA and entry chamfer shall have a surface roughness of 3.2µm (roughness grade N8).

4.8 ENVIRONMENTAL AND ENDURANCE TESTS (CHARTS IV AND V OF ESCC GENERIC SPECIFICATION NO. 3401)

4.8.1 Measurements and Inspections on Completion of Environmental Tests

The parameters to be measured and inspections to be performed on completion of environmental testing shall be those specified in Table 6. Unless otherwise specified, these measurements shall be performed at $T_{amb} = +22 \pm 3^{\circ}\text{C}$.

4.8.2 Measurements and Inspections at Intermediate Points during Endurance Tests

Not applicable.

4.8.3 Measurements and Inspections on Completion of Endurance Tests

The parameters to be measured and inspections to be performed on completion of endurance testing shall be those specified in Table 6. Unless otherwise specified, the measurements shall be performed at $T_{amb} = +22 \pm 3^{\circ}\text{C}$.

4.8.4 Conditions for Operating Life Test (Part of Endurance Testing)

Not applicable.

4.8.5 Electrical Circuit for Operating Life Test (Figure 5)

Not applicable.

4.8.6 Conditions for High Temperature Storage Test (Part of Endurance Testing)

The requirements for the high temperature storage test are specified in Section 9 of ESCC Generic Specification No. 3401. The temperature to be applied shall be the maximum storage temperature specified in Table 1(b) of this specification.

Table 6 - MEASUREMENTS AND INSPECTIONS ON COMPLETION OF ENVIRONMENTAL AND ENDURANCE TESTING

No.	ESCC Generic Spec. No. 3401		Measurements and Inspections		Symbol	Limits		Unit			
	Environmental and Endurance Tests Note 1	Test Method and Conditions	Identification	Conditions		Min	Max				
01	Seal Test	Para. 9.9	ESCC 3401 Para. 9.9	-	-	Not applicable		-			
02	Wiring	Para. 9.10	Low Level Contact Resistance	-	R_{cl}	Not applicable		-			
03	Vibration	Para. 9.11	Initial Measurements	-	-	Record Values		-			
			Coupling screw(s) Unlocking Torque								
			Final Measurements			-	$\Delta T_{qe}/T_{qe}$		-25	+25	%
			Coupling screw(s) Unlocking Torque Drift								
Visual Examination	-	-	-	-							
04	Shock or Bump	Para. 9.12	Full Engagement Visual Examination	-	-	-	-	-			
05	Climatic Sequence	Para. 9.13	Dry Heat Insulation Resistance	At High Temperature Table 2, Item 1	R_i	10	-	$M\Omega$			

No.	ESCC Generic Spec. No. 3401		Measurements and Inspections		Symbol	Limits		Unit
	Environmental and Endurance Tests Note 1	Test Method and Conditions	Identification	Conditions		Min	Max	
			Low Air Pressure Voltage Proof Leakage Current Damp Heat Insulation Resistance Final Measurements External Visual Inspection Insulation Resistance Voltage Proof Leakage Current	Figure 1 Immediately after test Table 2, Item 1 After 1-24 hrs Recovery ESCC 3401 Para. 9.7 Table 2, Item 1 Table 2, Item 2	I_L R_i R_i I_L	ESCC 3401 Para. 9.13.5 100 - ESCC 3401 Para. 9.7 Table 2, Item 1 Table 2, Item 2	mA $M\Omega$ $M\Omega$ mA	
06	Plating Thickness	Para. 9.14	Thickness	-	-	Para. 4.4.3 of this spec.		-
07	Joint Strength (N/A to solder contacts)	Para. 9.15	ESCC 3401 Para. 9.15	-	-	Not applicable		-
08	Rapid Change of Temperature	Para. 9.16	Visual Examination Insulation Resistance Voltage Proof Leakage Current	- Table 2, Item 1 Table 2, Item 2	- R_i I_L	- - Table 2, Item 1 Table 2, Item 2	- $M\Omega$ mA	
09	Contact Retention (in Insert)	Para. 9.17 & Para. 4.3.4 of this spec.	Contact Displacement	Not applicable for male contacts	-	ESCC 3401 Para. 9.17		-
10	Endurance	Para. 9.18	Initial Measurements Mating/Unmating Forces Low Level Contact Resistance Mated Shell Conductivity Final Measurements Visual Examination Mating/Unmating Forces Low Level Contact Resistance Drift Mated Shell Conductivity Insulation Resistance Voltage Proof Leakage Current	- Table 2, Item 4 Table 2, Item 3 - - Table 2, Item 4 Table 2, Item 3 Table 2, Item 1 Table 2, Item 2	F R_{cl} V_d - F ΔR_{cl} V_d R_i I_L	Para. 4.3.5 of this spec. Record Values Not applicable - - Para. 4.3.5 of this spec - 3 Not applicable Table 2, Item 1 Table 2, Item 2	N $m\Omega$ mV - N $m\Omega$ mV $M\Omega$ mA	
11	Permanence of Marking	Para. 9.19	-	-	-	-	-	-
12	Mating/Unmating Forces	Para. 9.20	Force	-	F	Para. 4.3.5 of this spec		N
13	High Temperature Storage	Para. 9.21	Initial Measurements Low Level Contact Resistance Mated Shell Conductivity Final Measurements Visual Examination Mating/Unmating Forces	Table 2, Item 4 Table 2, Item 3 - -	R_{cl} V_d - F	Record Values Not applicable - - Para. 4.3.5 of this spec	$m\Omega$ mV - N	

No.	ESCC Generic Spec. No. 3401		Measurements and Inspections		Symbol	Limits		Unit
	Environmental and Endurance Tests Note 1	Test Method and Conditions	Identification	Conditions		Min	Max	
			Low Level Contact Resistance Drift	Table 2, Item 4	ΔR_{cl}	-	3	m Ω
			Rated Current Contact Resistance	Table 2, Item 5	R_{cr}	Table 2, Item 5		
			Mated Shell Conductivity	Table 2, Item 3	V_d	Not applicable		mV
			Insulation Resistance	Table 2, Item 1	R_i	Table 2, Item 1		M Ω
			Voltage Proof Leakage Current	Table 2, Item 2	I_L	Table 2, Item 2		mA
			Contact Retention (in Insert)	Para. 4.3.4 of this spec	-	ESCC 3401 Para. 9.17		N
14	Corrosion	Para. 9.22	Visual Examination	-	-	-	-	-
15	Insert Retention (in Shell)	Para. 9.23 & Para. 4.3.6 of this spec.	Visual Examination	-	-	Para. 4.3.6 of this spec.		-
16	Jackscrew Retention	Para. 9.24 and 4.3.7 of this spec	Visual Examination	-	-	Not applicable		-
17	High Temperature Measurements	Para. 9.25	Insulation Resistance	Table 2 Item 1	R_i	5000	-	M Ω
18	Overload Test	Para. 9.26	Internal Temperature	-	T	-	+100	$^{\circ}$ C
			Rated Current Contact Resistance	Table 2, Item 5	R_{cr}	Table 2, Item 5		m Ω
			Mated Shell Conductivity	Table 2, Item 3	V_d	Not applicable		mV
			Insulation Resistance	Table 2, Item 1	R_i	Table 2, Item 1		M Ω
			Voltage Proof Leakage Current	Table 2, Item 2	I_L	Table 2, Item 2		mA
19	Maintenance Aging	Para. 9.27	-	-	-	Not applicable		-
20	Engage/Separation Forces	Para. 9.28 & Para. 4.3.9 of this spec.	Force	-	F	Para. 4.3.9 of this spec.		N
21	Oversize Pin Exclusion	Para. 9.29 and 4.3.10 of this spec.	-	-	-	Not applicable		-
22	Probe Damage	Para. 9.30 and 4.3.11 of this spec.	Contact Separation Force	-	-	Not applicable		-
23	Solderability	Para. 9.31 & Para. 4.3.12 of this spec.	-	-	-	Not applicable		-

NOTES:

1. The tests in this Table refer to either Chart IV or V and shall be used as applicable.

APPENDIX 'A' - AGREED DEVIATIONS FOR C & K COMPONENTS (F)

ITEMS AFFECTED	DESCRIPTION OF DEVIATIONS
Para. 4.2.2, Deviations from Final Production Tests (Chart II)	Para. 9.4, Contact Capability: 100% Contact Capability Test may be omitted provided that a 100% visual inspection of the contacts is performed on each batch submitted to tests defined in the C&K PID requirements.