



Pages 1 to 21

**CAPACITORS, FIXED,
CERAMIC DIELECTRIC, TYPE I,
HIGH VOLTAGE, 1.0 to 5.0 kV
BASED ON CASE STYLES VR, CV AND CH
ESCC Detail Specification No. 3001/033**

**ISSUE 3
May 2009**



Document Custodian: European Space Agency - see <https://escies.org>

	ESCC Detail Specification No. 3001/033		PAGE i ISSUE 3
---	---	--	-------------------

LEGAL DISCLAIMER AND COPYRIGHT

European Space Agency, Copyright © 2009. All rights reserved.

The European Space Agency disclaims any liability or responsibility, to any person or entity, with respect to any loss or damage caused, or alleged to be caused, directly or indirectly by the use and application of this ESCC publication.

This publication, without the prior permission of the European Space Agency and provided that it is not used for a commercial purpose, may be:

- copied in whole in any medium without alteration or modification.
- copied in part, in any medium, provided that the ESCC document identification, comprising the ESCC symbol, document number and document issue, is removed.

DOCUMENTATION CHANGE NOTICE

(Refer to <https://escies.org> for ESCC DCR content)

DCR No.	CHANGE DESCRIPTION
484	Specification upissued to incorporate editorial changes per DCR.



TABLE OF CONTENTS

	<u>Page</u>
1. <u>GENERAL</u>	5
1.1 Scope	5
1.2 Component Type Variants and Range of Components	5
1.3 Maximum Ratings	5
1.4 Parameter Derating Information	5
1.5 Physical Dimensions	5
1.6 Functional Diagram	5
2. <u>APPLICABLE DOCUMENTS</u>	12
3. <u>TERMS, DEFINITIONS, ABBREVIATIONS, SYMBOLS AND UNITS</u>	12
4. <u>REQUIREMENTS</u>	12
4.1 General	12
4.2 Deviations from Generic Specification	12
4.2.1 Deviations from Special In-process Controls	12
4.2.2 Deviations from Final Production Tests	12
4.2.3 Deviations from Burn-in and Electrical Measurements	12
4.2.4 Deviations from Qualification Tests	12
4.2.5 Deviations from Lot Acceptance Tests	12
4.3 Mechanical Requirements	13
4.3.1 Dimension Check	13
4.3.2 Weight	13
4.3.3 Robustness of Terminations	13
4.4 Materials and Finishes	13
4.4.1 Encapsulation	13
4.4.2 Leads	13
4.5 Marking	13
4.5.1 General	13
4.5.2 The ESCC Component Number	13
4.5.3 Electrical Characteristics and Ratings	14
4.5.4 Traceability Information	15
4.6 Electrical Measurements	15
4.6.1 Electrical Measurements at Room Temperature	15
4.6.2 Electrical Measurements at High and Low Temperatures	15
4.6.3 Circuits for Electrical Measurements	15
4.7 Burn-in Tests	15
4.7.1 Parameter Drift Values	15
4.7.2 Conditions for Burn-in	15
4.7.3 Electrical Circuit for Burn-in	15
4.8 Environmental and Endurance Tests	18
4.8.1 Measurements and Inspections on Completion of Environmental Tests	18
4.8.2 Measurements and Inspections at Intermediate Points during Endurance Tests	18
4.8.3 Measurements and Inspections on Completion of Endurance Tests	18
4.8.4 Conditions for Operating Life Tests	18
4.8.5 Electrical Circuit for Operating Life Tests	18



		<u>Page</u>
<u>TABLES</u>		
1(a)	Type Variants and Range of Components	6
1(b)	Maximum Ratings	7
2	Electrical Measurements at Room Temperature	16
3	Electrical Measurements at High and Low Temperatures	16
4	Parameter Drift Values	17
5	Conditions for Burn-in and Operating Life Tests	17
6	Measurements and Inspections on Completion of Environmental Tests and at Intermediate Points and on Completion of Endurance Testing	19
<u>FIGURES</u>		
1	Parameter Derating Information	N/A
2	Physical Dimensions	8
3	Functional Diagram	11
4	Circuits for Electrical Measurements	N/A
5	Electrical Circuit for Burn-in and Operating Life Tests	N/A
<u>APPENDICES (Applicable to specific Manufacturers only)</u>		
'A'	Agreed Deviations for AVX Ltd, Coleraine (G.B.)	21



1. **GENERAL**

1.1 **SCOPE**

This specification details the ratings, physical and electrical characteristics, test and inspection data for a Capacitor, Fixed, Ceramic Dielectric, Type I, High Voltage, 1 to 5 kV, based on Case Styles VR, CV and CH. It shall be read in conjunction with ESCC Generic Specification No. 3001, the requirements of which are supplemented herein.

1.2 **COMPONENT TYPE VARIANTS AND RANGE OF COMPONENTS**

The variants and range of components covered by this specification are given in Table 1(a).

1.3 **MAXIMUM RATINGS**

The maximum ratings, which shall not be exceeded at any time during use or storage, applicable to the capacitors specified herein are scheduled in Table 1(b).

1.4 **PARAMETER DERATING INFORMATION (FIGURE 1)**

Not applicable.

1.5 **PHYSICAL DIMENSIONS**

The physical dimensions of the capacitors specified herein are shown in Figure 2.

1.6 **FUNCTIONAL DIAGRAM**

The functional diagram for the capacitors specified herein is shown in Figure 3.



ESCC Detail Specification

No. 3001/033

PAGE 6

ISSUE 3

TABLE 1(a) - TYPE VARIANTS AND RANGE OF COMPONENTS

Variant	Case Size	Total Number of Leads	Figure	Capacitance Range (pF) (E12)				Weight (g)
				1.0kV	2.0kV	3.0kV	4.0kV	
01	VR30S	2	2(a)	390 to 2 200	56 to 470	33 to 330		1.0
02	VR30	2	2(a)	2 700 to 5 600	560 to 1 800	390 to 680		1.0
03	VR40	2	2(a)	6 800 to 15 000	2 200 to 4 700	820 to 1 500	390 to 820	2.0
04	VR50	2	2(a)	18 000 to 33 000	5 600 to 10 000	1 800 to 2 700	1 000 to 1 800	3.0
05	VR66	2	2(a)	39 000 to 68 000	12 000 to 18 000	3 300 to 5 600	2 200 to 3 300	5.0
06	VR84	2	2(a)	82 000 to 100 000	22 000 to 39 000	6 800 to 12 000	3 900 to 6 800	8.0
07	VR90	2	2(a)	120 000 to 330 000	47 000 to 100 000	15 000 to 33 000	8 200 to 18 000	19.0
08	CV41	2	2(b)	6 800 to 15 000	2 200 to 4 700	820 to 1 500	390 to 820	2.0
09	CH41	6	2(c)	6 800 to 15 000	2 200 to 4 700	820 to 1 500	390 to 820	2.0
10	CH41	6	2(d)	6 800 to 15 000	2 200 to 4 700	820 to 1 500	390 to 820	2.0
11	CV51	2	2(b)	18 000 to 33 000	5 600 to 10 000	1 800 to 2 700	1 000 to 1 800	3.0
12	CH51	8	2(c)	18 000 to 33 000	5 600 to 10 000	1 800 to 2 700	1 000 to 1 800	3.0
13	CH51	8	2(d)	18 000 to 33 000	5 600 to 10 000	1 800 to 2 700	1 000 to 1 800	3.0
14	CV61	2	2(b)	39 000 to 68 000	12 000 to 18 000	3 300 to 5 600	2 200 to 3 300	5.0
15	CH61	10	2(c)	39 000 to 68 000	12 000 to 18 000	3 300 to 5 600	2 200 to 3 300	5.0
16	CH61	10	2(d)	39 000 to 68 000	12 000 to 18 000	3 300 to 5 600	2 200 to 3 300	5.0
17	CV76	2	2(b)	82 000 to 100 000	22 000 to 39 000	6 800 to 12 000	3 900 to 6 800	8.0
18	CH76	12	2(c)	82 000 to 100 000	22 000 to 39 000	6 800 to 12 000	3 900 to 6 800	8.0
19	CH76	12	2(d)	82 000 to 100 000	22 000 to 39 000	6 800 to 12 000	3 900 to 6 800	8.0
20	CV91	2	2(b)	120 000 to 330 000	47 000 to 100 000	15 000 to 33 000	8 200 to 18 000	19.0
21	CH91	28	2(c)	120 000 to 330 000	47 000 to 100 000	15 000 to 33 000	8 200 to 18 000	19.0
22	CH91	28	2(d)	120 000 to 330 000	47 000 to 100 000	15 000 to 33 000	8 200 to 18 000	19.0

NOTES

1. Tolerances of $\pm 5\%$, $\pm 10\%$ and $\pm 20\%$ are available.
2. For CH types, both D.I.L. and L style leads are available (see Figure 2).

TABLE 1(b) - MAXIMUM RATINGS

No.	Characteristics	Symbol	Limits		Unit	Remarks
			Min.	Max.		
1	Rated Voltage	U_R	See Table 1(a)		V	
2	Operating Temperature Range	T_{op}	- 55	+ 125	°C	Without derating. T_{amb}
3	Storage Temperature Range	T_{stg}	- 55	+ 125	°C	
4	Soldering Temperature	T_{sol}	-	+ 260	°C	Note 1

NOTES

1. Duration 5 seconds maximum at a distance of not less than 1.5mm from the device body and the same lead shall not be resoldered until 3 minutes have elapsed.

FIGURE 1 - PARAMETER DERATING INFORMATION

Not applicable.

FIGURE 2 - PHYSICAL DIMENSIONS

FIGURE 2(a) - VR STYLE

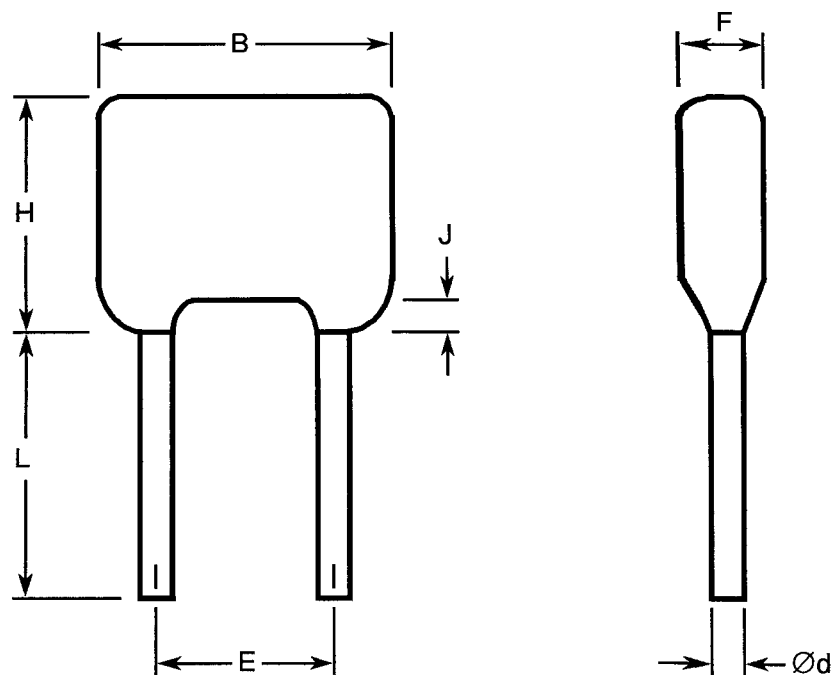

Variant	Case Size	Dimensions (mm)								
		B	Ød		E		F	H	J	L
		(max)	(min)	(max)	(min)	(max)	(max)	(max)	(max)	(min)
01	VR30S	7.62	0.46	0.56	4.58	5.58	5	4.6	1.5	31.7
02	VR30	7.62	0.46	0.56	4.58	5.58	5	9.62	1.5	31.7
03	VR40	10.16	0.46	0.56	4.58	5.58	5	11.7	1.5	31.7
04	VR50	12.7	0.59	0.69	9.66	10.66	5.1	14.2	1.5	31.7
05	VR66	17.5	0.86	0.96	14.2	15.2	6.4	16.50	1.5	31.7
06	VR84	23.62	0.86	0.96	20.4	22	6.4	19.78	1.5	31.7
07	VR90	23.5	0.86	0.96	20.4	22	6.4	42.00	1.5	31.7

FIGURE 2 - PHYSICAL DIMENSIONS (CONTINUED)

FIGURE 2(b) - CV STYLE

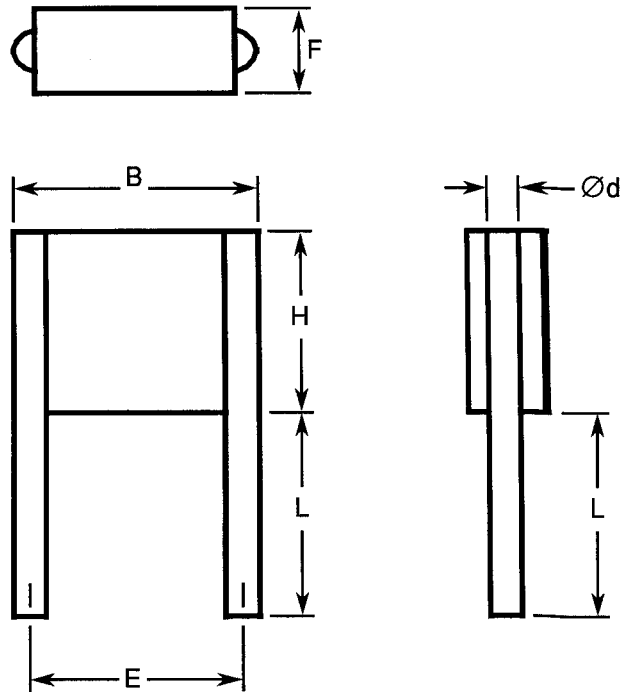

Variant	Case Size	Dimensions (mm)								
		B	$\varnothing d$		E		F	H	L	
		(max)	(min)	(max)	(min)	(max)	(max)	(max)	(min)	(max)
08	CV41	10.6	0.65	0.75	7.7	8.7	3.8	8.7	22	28
11	CV51	11.9	0.85	0.95	9.66	10.66	3.8	10.7	22	28
14	CV61	16.5	0.85	0.95	14.74	15.74	3.8	13.6	22	28
17	CV76	22.7	0.85	0.95	20.4	22	3.8	16.6	22	28
20	CV91	22.7	1.15	1.25	20.4	22	3.8	40.6	22	28

FIGURE 2 - PHYSICAL DIMENSIONS (CONTINUED)

FIGURE 2(c) - CH STYLE, D.I.L.

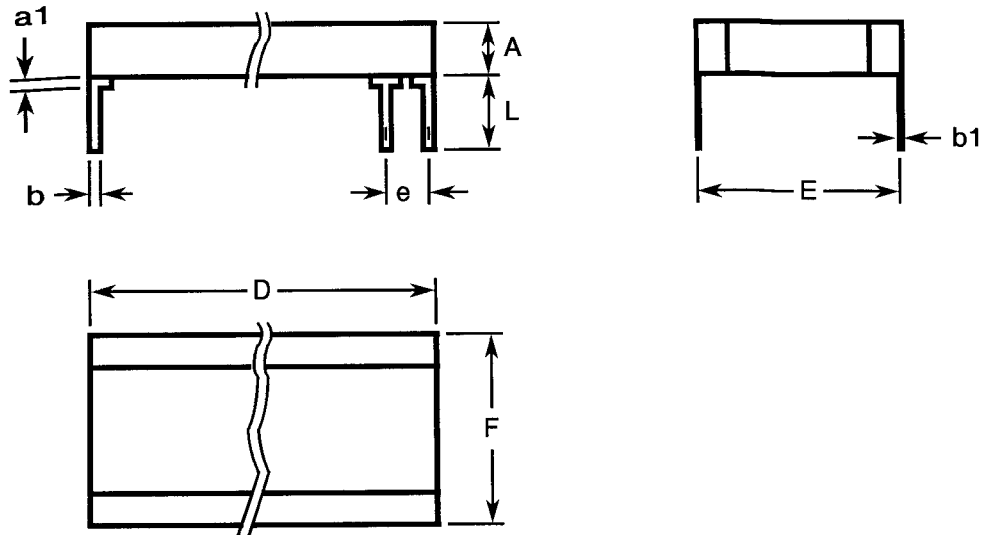

Variant	Case Size	Dimensions (mm)				
		A	D	E		F
		(max)	(max)	(min)	(max)	(max)
09	CH41	3.8	8.7	7.70	8.7	9.2
12	CH51	3.8	10.7	9.66	10.66	10.7
15	CH61	3.8	13.6	13.5	14.5	14.9
18	CH76	3.8	16.6	19.52	21.12	21.6
21	CH91	3.8	40.6	19.52	21.12	24

Symbol	Millimetres		Notes
	Min	Max	
a1	-	2	1
b	0.45	0.55	1
b1	0.204	0.304	1
e	2.49	2.59	2
L	12	14	1

NOTES

1. All leads.
2. Each space.

FIGURE 2 - PHYSICAL DIMENSIONS (CONTINUED)

FIGURE 2(d) - CH STYLE, L

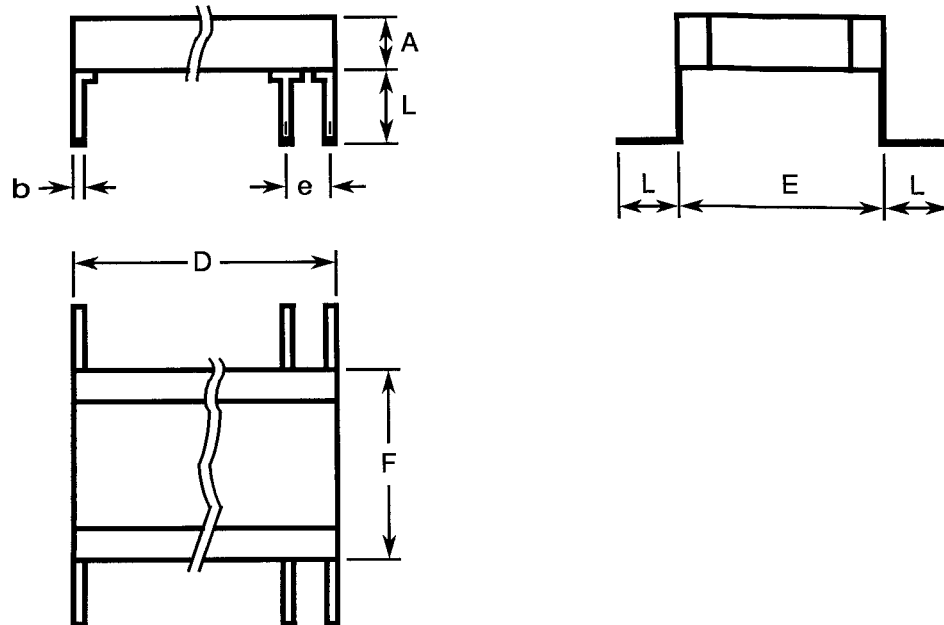

Variant	Case Size	Dimensions (mm)				
		A	D	E		F
		(max)	(max)	(min)	(max)	(max)
10	CH41	3.8	8.7	7.7	8.7	9.2
13	CH51	3.8	10.7	9.66	10.66	10.7
16	CH61	3.8	13.6	13.5	14.5	14.9
19	CH76	3.8	16.6	19.52	21.12	21.6
22	CH91	3.8	40.6	19.52	21.12	24

Symbol	Millimetres		Notes
	Min	Max	
b	0.45	0.55	1
e	2.49	2.59	2
L	2.04	3.04	1

NOTES

1. All leads.
2. Each space.

FIGURE 3 - FUNCTIONAL DIAGRAM

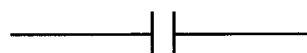

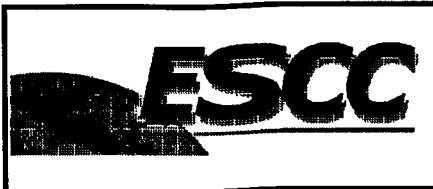

2. APPLICABLE DOCUMENTS

The following documents form part of this specification and shall be read in conjunction with it:-

- (a) ESCC Generic Specification No. 3001 for Capacitors, Fixed, Ceramic Dielectric, Types I and II.

3. TERMS, DEFINITIONS, ABBREVIATIONS, SYMBOLS AND UNITS

For the purpose of this specification, the terms, definitions, abbreviations, symbols and units specified in ESCC Basic Specification No. 21300 shall apply. In addition the following symbol is used:-

V_T = Test Voltage.

4. REQUIREMENTS

4.1 GENERAL

The complete requirements for procurement of the capacitors specified herein are stated in this specification and ESCC Generic Specification No. 3001 for Capacitors, Fixed, Ceramic Dielectric, Types I and II. Deviations from the Generic Specification, applicable to this specification only, are listed in Para. 4.2.

Deviations from the applicable Generic Specification and this Detail Specification, formally agreed with specific Manufacturers on the basis that the alternative requirements are equivalent to the ESCC requirements and do not affect the components' reliability, are listed in the appendices attached to this specification.

4.2 DEVIATIONS FROM GENERIC SPECIFICATION

4.2.1 Deviations from Special In-process Controls

- (a) Para. 5.2.3, Robustness of Terminations: Shall be replaced with a Lead Peel test as follows:-

1. Where necessary, bend the leads of the capacitor through 90° in the plane of the joint.
2. Apply a tensile force to the bend section of the lead until the joint peels.
3. The minimum peeling force shall be 8.9 Newtons for VR and CV Styles and 22.25 Newtons for CH Styles.

4.2.2 Deviations from Final Production Tests (Chart II)

- (a) Para. 9.2.1, Drying: Shall not be performed.
(b) Para. 9.5.1.4.1(b), Voltage Proof - Body Insulation: Not applicable for Variants 08 to 22.

4.2.3 Deviations from Burn-in and Electrical Measurements (Chart III)

- (a) Para. 9.6, Radiographic Inspection: Not applicable for Variants 08 to 22.
(b) Para. 9.5.1.4.1(b), Voltage Proof - Body Insulation: Not applicable for Variants 08 to 22.

4.2.4 Deviations from Qualification Tests (Chart IV)

- (a) Para. 9.5.1.4.1(b), Voltage Proof - Body Insulation: Not applicable for Variants 08 to 22.

4.2.5 Deviations from Lot Acceptance Tests (Chart V)

- (a) Para. 9.5.1.4.1(b), Voltage Proof - Body Insulation: Not applicable for Variants 08 to 22.

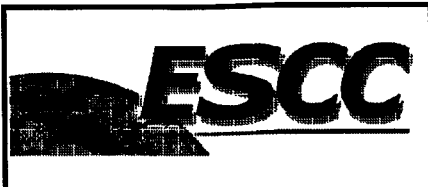

4.3 MECHANICAL REQUIREMENTS

4.3.1 Dimension Check

The dimensions of the capacitors specified herein shall be verified in accordance with the requirements set out in Para. 9.4 of ESCC Generic Specification No. 3001 and they shall conform to those shown in Figure 2 of this specification.

4.3.2 Weight

The maximum weight of the capacitors specified herein shall be as scheduled in Table 1(a).

4.3.3 Robustness of Terminations

The terminations of these devices are defined as 'rigid'.

4.4 MATERIALS AND FINISHES

The materials and finishes shall be as specified herein. Where a definite material is not specified, a material which will enable the capacitors specified herein to meet the performance requirements of this specification shall be used. Acceptance or approval of any constituent material does not guarantee acceptance of the finished product.

4.4.1 Encapsulation

Variants 01 to 07 shall be coated in epoxy resin.
Variants 08 to 22 are classified as "non-insulated".

4.4.2 Leads

- (a) For Variants 01 to 08, 11, 14, 17 and 20, the lead material shall be Type A with Type 3 finish in accordance with the requirements of ESCC Basic Specification No. 23500.
- (b) For Variants 09, 10, 12, 13, 15, 16, 18, 19, 21 and 22, the lead material shall be Type N with Type 9 finish in accordance with the requirements of ESCC Basic Specification No. 23500.

4.5 MARKING

4.5.1 General

The marking of components delivered to this specification shall be in accordance with the requirements of ESCC Basic Specification No. 21700 and the following paragraphs. When the component is too small to accommodate all of the marking specified, as much as space permits shall be marked and the marking information, in full, shall accompany the component in its primary package.

The information to be marked and the order of precedence, shall be as follows:-

- (a) The ESCC Component Number.
- (b) Electrical Characteristics and Ratings.
- (c) Traceability Information.

4.5.2 The ESCC Component Number

The ESCC Component Number shall be constituted and marked as follows:-

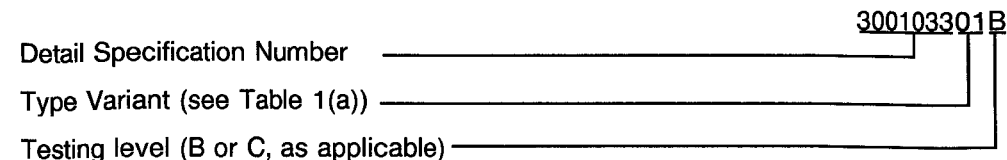

4.5.3 Electrical Characteristics and Ratings

The electrical characteristics and ratings to be marked in the following order of precedence are:-

- (a) Capacitance Value.
- (b) Tolerance.
- (c) Rated Voltage.

The information shall be constituted and marked as follows:-

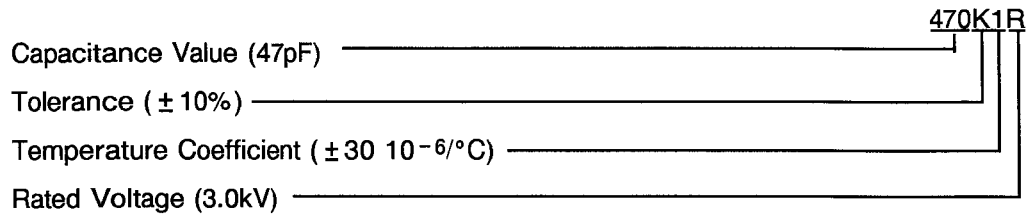

4.5.3.1 Capacitance Values

The capacitance values shall be expressed by means of the following codes. The unit quantity for marking shall be picofarads.

Capacitance Value	Code
XX	XX0
XX10 ¹	XX1
XX10 ²	XX2
XX10 ³	XX3
XX10 ⁴	XX4
XX10 ⁵	XX5
XX10 ⁶	XX6

4.5.3.2 Tolerances

The tolerances on capacitance values shall be indicated by the code letters specified hereafter.

Tolerance (%)	Code Letter
± 5.0	J
± 10	K
± 20	M

4.5.3.3 Temperature Coefficient

The temperature coefficient shall be indicated by the code numbers specified hereafter.

10 ⁻⁶ /°C	Code Number
± 30	1

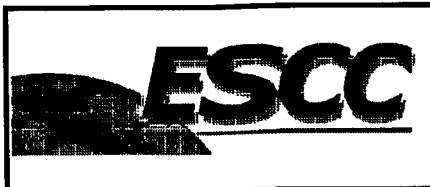

4.5.3.4 Rated Voltage

The rated voltage shall be indicated by the code letters specified hereafter.

Rated Voltage (kV)	Code Letter
1	M
2	P
3	R
4	S
5	Z

4.5.4 Traceability Information

Traceability information shall be marked in accordance with the requirements of ESCC Basic Specification No. 21700.

4.6 ELECTRICAL MEASUREMENTS

4.6.1 Electrical Measurements at Room Temperature

The parameters to be measured at room temperature are scheduled in Table 2. Unless otherwise specified, measurements shall be performed at $T_{amb} = +22 \pm 3$ °C.

4.6.2 Electrical Measurements at High and Low Temperatures

The parameters to be measured at high and low temperatures are scheduled in Table 3. The measurements shall be performed at $T_{amb} = +125(+0-5)$ and $-55(+5-0)$ °C respectively.

4.6.3 Circuits for Electrical Measurements

A circuit for use in performing the electrical measurements listed in Table 2 of this specification is shown in ESCC Generic Specification No. 3001.

4.7 BURN-IN TESTS

4.7.1 Parameter Drift Values

The parameter drift values applicable to burn-in are specified in Table 4 of this specification. Unless otherwise stated, measurements shall be performed at $T_{amb} = +22 \pm 3$ °C.

The parameter drift values (Δ) applicable to the parameters scheduled shall not be exceeded. In addition to these drift value requirements for a given parameter, the appropriate limit value specified in Table 2 shall not be exceeded.

4.7.2 Conditions for Burn-in

The requirements for burn-in are specified in Section 7 of ESCC Generic Specification No. 3001. The conditions for burn-in shall be as specified in Table 5 of this specification.

4.7.3 Electrical Circuit for Burn-in (Figure 5)

Not applicable.

TABLE 2 - ELECTRICAL MEASUREMENTS AT ROOM TEMPERATURE

No.	Characteristics	Symbol	ESCC 3001 Test Conditions	Limits		Unit	Remarks
				Min	Max		
1	Capacitance	C	Para. 9.5.1.1	See Table 1(a)		pF	
2	Tangent of Loss Angle	Tgδ	Para. 9.5.1.2	-	10	10 ⁻⁴	
3	Insulation Resistance	R _i R _i × C	Para. 9.5.1.3 C ≤ 10 000pF C > 10 000pF	100 1000	- -	GΩ sec	Note 1
4	Voltage Proof - Dielectric	VP	Para. 9.5.1.4 U _R ≤ 1250V U _R > 1250V	1.5U _R 1.3U _R	- -	V	Note 1
5	Voltage Proof - Body Insulation	VP _B	Para. 9.5.1.4 U _R ≤ 1250V U _R > 1250V	1.5U _R 1.3U _R	- -	V	Note 2

NOTES

1. Variants 08 to 22 are classified as “non-insulated”.
2. Variants 01 to 07 only.

TABLE 3 - ELECTRICAL MEASUREMENTS AT HIGH AND LOW TEMPERATURES

No.	Characteristics	Symbol	ESCC 3001 Test Conditions	Limits		Unit	Remarks
				Min	Max		
3	Insulation Resistance at T _{amb} = + 125 ± 3 °C	R _i R _i × C	Para. 9.5.1.3 C ≤ 10 000pF C > 10 000pF	10 100	- -	GΩ sec	Notes 1, 2 and 3
6(i)	Temperature Coefficient	TC	Para. 9.16 Between - 55 and +20 ± 2 °C Between +20 ± 2 and +125 °C	- 30 - 30	+ 30 + 30	10 ⁻⁶ /°C	5 parts for each capacitance value Notes 3 and 5
6(ii)	Temperature Coefficient	TC	Para. 9.16 Between +20 ± 2 and +125 °C	- 30	+ 30	10 ⁻⁶ /°C	5 parts for each fired ceramic lot Notes 4 and 5

NOTES

1. Single sample: Inspection Level S3, AQL = 2.5%.
2. Variants 08 to 22 are classified as “non-insulated”.
3. Applicable to Level ‘B’ only.
4. Applicable to Level ‘C’ only.
5. If 1 failure occurs out of 5 parts, then test 100%. 1% rejects maximum allowed in the case of 100% testing.

FIGURE 4 - CIRCUITS FOR ELECTRICAL MEASUREMENTS

Not applicable.

TABLE 4 - PARAMETER DRIFT VALUES

No.	Characteristics	Symbol	Spec. and/or Test Method	Test Conditions	Change Limits (Δ)	Unit
1	Capacitance Change	$\frac{\Delta C}{C}$	As per Table 2	As per Table 2	± 1	%

TABLE 5 - CONDITIONS FOR BURN-IN AND OPERATING LIFE TESTS

No.	Characteristic	Symbol	Condition	Unit
1	Ambient Temperature	T_{amb}	+ 125(+ 0 - 3)	°C
2	Test Voltage	V_T	$U_R \leq 1250V: 1.3U_R$ $U_R > 1250V: 1.0U_R$	V

FIGURE 5 - ELECTRICAL CIRCUIT FOR BURN-IN AND OPERATING LIFE TESTS

Not applicable.

	<p style="text-align: center;">ESCC Detail Specification No. 3001/033</p>		<p>PAGE 18 ISSUE 3</p>
---	---	--	----------------------------

4.8 ENVIRONMENTAL AND ENDURANCE TESTS (CHARTS IV AND V OF ESCC GENERIC SPECIFICATION NO. 3001)

4.8.1 Measurements and Inspections on Completion of Environmental Tests

The parameters to be measured and inspections to be performed on completion of environmental tests are scheduled in Table 6. Unless otherwise stated, the measurements shall be performed at $T_{amb} = +22 \pm 3 \text{ }^\circ\text{C}$.

4.8.2 Measurements and Inspections at Intermediate Points during Endurance Tests

The parameters to be measured and inspections to be performed at intermediate points during endurance tests are scheduled in Table 6. Unless otherwise stated, the measurements shall be performed at $T_{amb} = +22 \pm 3 \text{ }^\circ\text{C}$.

4.8.3 Measurements and Inspections on Completion of Endurance Tests

The parameters to be measured and inspections to be performed on completion of endurance testing are scheduled in Table 6. Unless otherwise stated, the measurements shall be performed at $T_{amb} = +22 \pm 3 \text{ }^\circ\text{C}$.

4.8.4 Conditions for Operating Life Tests (Part of Endurance Testing)

The requirements for operating life testing are specified in Section 9 of ESCC Generic Specification No. 3001. The conditions for operating life testing shall be as specified in Table 5 for the burn-in test

4.8.5 Electrical Circuit for Operating Life Tests (Figure 5)

Not applicable.

TABLE 6 - MEASUREMENTS AND INSPECTIONS ON COMPLETION OF ENVIRONMENTAL TESTS AND AT INTERMEDIATE POINTS AND ON COMPLETION OF ENDURANCE TESTING

NO.	ESCC GENERIC SPEC.NO. 3001		MEASUREMENTS AND INSPECTIONS		SYMBOL	LIMITS		UNIT
	ENVIRONMENTAL AND ENDURANCE TESTS (1)	TEST METHOD AND CONDITIONS	IDENTIFICATION	CONDITIONS		MIN.	MAX.	
01	Robustness of Terminations	Para. 9.7 and Para. 4.3.3 of this specification	Visual Examination	-	-	-	-	-
02	Resistance to Soldering Heat	Para. 9.8	Initial Measurements Capacitance	Table 2 Item 1	C	Table 2 Item 1		pF
			Final Measurements Capacitance Change Insulation Resistance	After a recovery period of 24 ± 2 hours Table 2 Item 1 Table 2 Item 3	ΔC/C Ri or Ri × C	-1	+1	% GΩ sec
03	Solderability	Para. 9.9	Visual Examination	-	-	-	-	-
04	Rapid Change of Temperature	Para. 9.10	Initial Measurements Capacitance	Table 2 Item 1	C	Table 2 Item 1		pF
			Final Measurements Visual Examination Capacitance Change Tangent of Loss Angle	After a recovery period of 24 ± 2 hours - Table 2 Item 1 Table 2 Item 2	- ΔC/C Tgδ	-	+1	- % 10 ⁻⁴
05	Vibration	Para. 9.11	During Last Cycle Intermittent Contact	Para. 9.11.3 Open or Shorts	-	-	-	-
			After Test Visual Examination	-	-	-	-	-
06	Shock or Bump	Para. 9.12	Visual Examination	-	-	-	-	-
07	Climatic Sequence	Para. 9.13	Initial Measurements Capacitance	Table 2 Item 1	C	Table 2 Item 1		pF
			Final Measurements	After a recovery period of 1 to 24 hours				
			External Visual Inspection	Para. 9.3 of ESCC 3001	-	-	-	-
			Capacitance Change	Table 2 Item 1	ΔC/C	-2	+2	%
			Tangent of Loss Angle	Table 2 Item 2	Tgδ	2 × Table 2 Item 2		10 ⁻⁴
Insulation Resistance	Table 2 Item 3	Ri or Ri × C	10	-	GΩ			
Voltage Proof - Body Insulation	Table 2 Item 5	VP _B	100	-	sec			
						Table 2 Item 5	V	

NOTES

1. The tests in this Table refer to either Chart IV or V and shall be used as applicable.

TABLE 6 - MEASUREMENTS AND INSPECTIONS ON COMPLETION OF ENVIRONMENTAL TESTS AND AT INTERMEDIATE POINTS AND ON COMPLETION OF ENDURANCE TESTING (CONT'D)

NO.	ESCC GENERIC SPEC.NO. 3001		MEASUREMENTS AND INSPECTIONS		SYMBOL	LIMITS		UNIT					
	ENVIRONMENTAL AND ENDURANCE TESTS (1)	TEST METHOD AND CONDITIONS	IDENTIFICATION	CONDITIONS		MIN.	MAX.						
08	Damp Heat, Steady State	Para. 9.14	Initial Measurements	Table 2 Item 1 After a recovery period of 6 to 24 ± 2 hours	C	Table 2 Item 1		pF					
			Capacitance										
			Final Measurements										
			Visual Examination						-	-	-		
			Capacitance Change						Table 2 Item 1	ΔC/C	-2	+2	%
			Tangent of Loss Angle						Table 2 Item 2	Tgδ	2 × Table 2 Item 2		10 ⁻⁴
Insulation Resistance	Table 2 Item 3	Ri or Ri × C	10	-	GΩ								
			Voltage Proof - Body Insulation	Table 2 Item 5	VP _B	100	-	sec					
						Table 2 Item 5		V					
09	Operating Life	Para. 9.15 Change limits relate to initial (0- hour) measurements	Initial Measurements	Table 2 Item 1 After a recovery period of 1 hour minimum Table 2 Item 1 Table 2 Item 3 After a recovery period of 24 ± 2 hours Table 2 Item 1 Table 2 Item 2 Table 2 Item 3 Table 2 Item 4 Table 2 Item 5 -	C	Table 2 Item 1		pF					
			Capacitance										
			Intermediate Measurements										
			Capacitance Change						Table 2 Item 1	ΔC/C	-3	+3	%
			Insulation Resistance						Table 2 Item 3	Ri or Ri × C	10	-	GΩ
											100	-	sec
			Final Measurements										
			Capacitance Change						Table 2 Item 1	ΔC/C	-3	+3	%
			Tangent of Loss Angle						Table 2 Item 2	Tgδ	2 × Table 2 Item 2		10 ⁻⁴
			Insulation Resistance						Table 2 Item 3	Ri or Ri × C	10	-	GΩ
			Voltage Proof - Dielectric	Table 2 Item 4	VP	100	-	sec					
			Voltage Proof - Body Insulation	Table 2 Item 5	VP _B	Table 2 Item 4		V					
			Visual Examination	-	-	-	-	-					
						Table 2 Item 5		V					
10	Temperature Coefficient	Para. 9.16	Temperature Coefficient	Table 3 Item 6(i) or 6(ii)	TC	Table 3 Item 6(i) or 6(ii)		10 ⁻⁶ /°C					

NOTES

1. The tests in this Table refer to either Chart IV or V and shall be used as applicable.

	<p>ESCC Detail Specification No. 3001/033</p>		<p>PAGE 21 ISSUE 3</p>
---	---	--	----------------------------

APPENDIX 'A'

Page 1 of 1

AGREED DEVIATIONS FOR AVX LTD, COLERAINE (G.B.)

ITEMS AFFECTED	DESCRIPTION OF DEVIATIONS
Para. 4.2.1	Microsectioning may be performed using AVX document COL/EMP/04-20 (Issue as per P.I.D.).
Paras. 4.2.2/3/4/5	Para. 9.1 and 9.3 : Internal and External Visual Inspection may be performed using AVX document LAR/AP/30-14 (Issue as per P.I.D.).
Para. 4.2.3	Para. 9.6, "Radiographic Inspection": View 2 may be omitted for Variants 01 to 07.