

Micro-Link 1 (ML-1)

~~NanoSpace-1~~: Spacecraft Architecture and Design after Concluding Phase B

Fredrik Bruhn^{1,2} and Lars Stenmark^{1,2}

¹ Ångström Aerospace Corporation (ÅAC)

² Ångström Space Technology Centre (ÅSTC)



5th Round Table on Micro Nano
Technologies 2005

Acknowledgment:

Peter Rathsman, Swedish Space Corporation (SSC)

Swedish National Space Board (SNSB)

www.aerospace.com

Spacecraft Summary

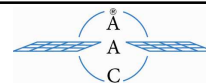

- Less than 10 kg satellite comprising
 - Multifunctional spacecraft design
 - Distributed, redundant, and scalable system architecture
 - >40 MMS silicon modules
 - 3 axis stabilized (~70 m/s ΔV)
 - Li-Ion batteries
 - CAN, SpaceWire (SpW)
 - 1 Mbit/s telemetry downlink (S-band)



Ångström Aerospace Corporation

www.aerospace.com

Sida 2

Mission Outline

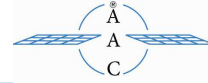

- *Phase 1* – System commissioning, both satellites
- *Phase 2* – Separation / docking manoeuvres
- *Phase 3* – Close-range formation flying
- *Phase 4* – Near-range flying
- *Phase 5* – High accuracy pointing test / verification
Precision pointing using Cold Gas Microthrusters
- *Phase 6* – Orbital change manoeuvre and post-formation flying

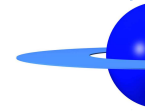

Systems Design Strategy (1)

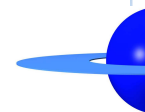
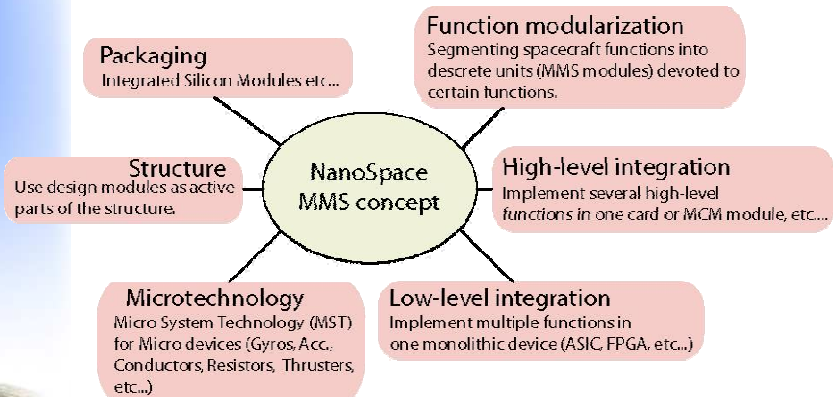
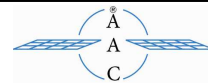

Systems Designs Strategy (2)

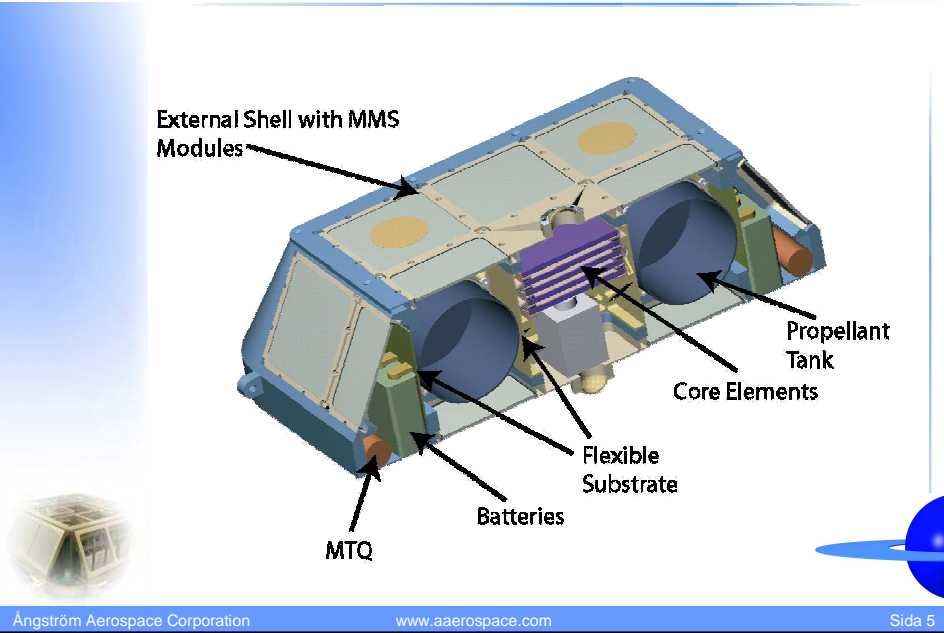

Flight Configuration

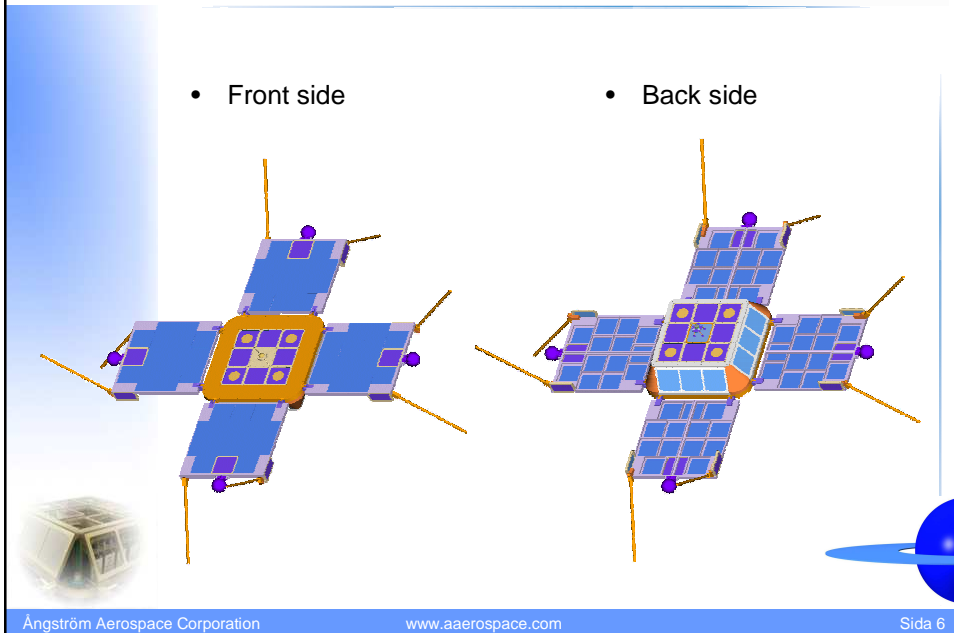
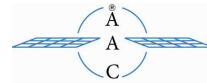

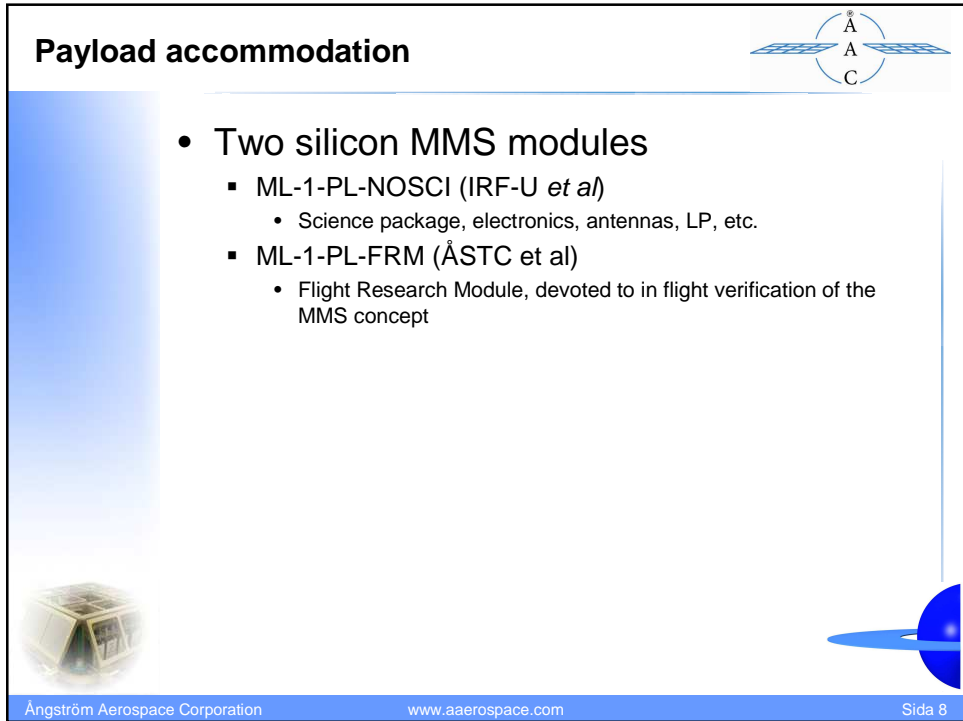
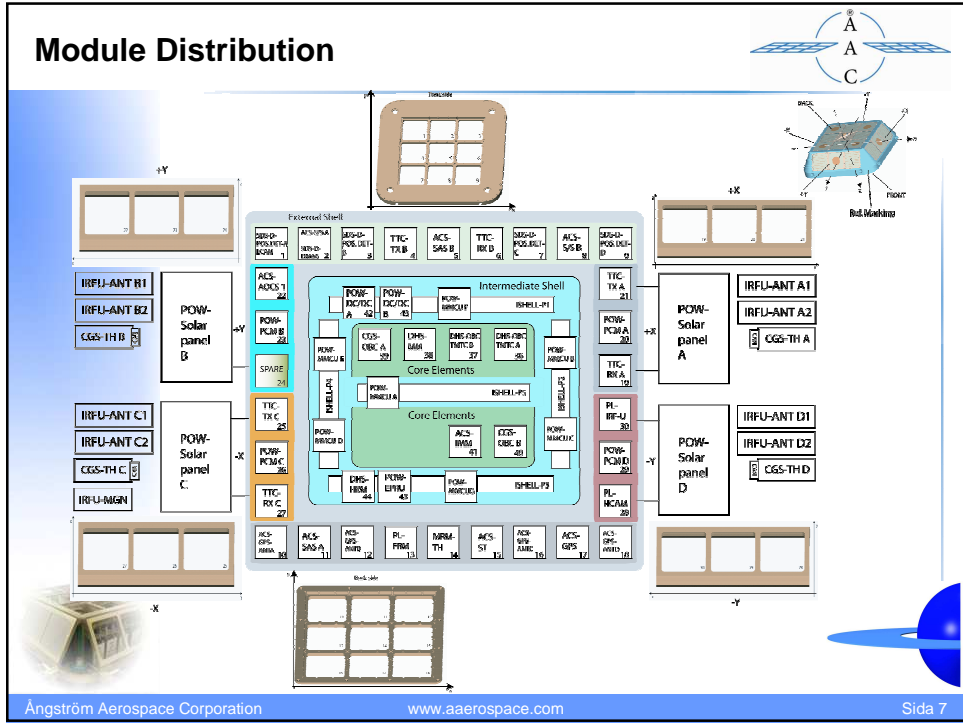

Mass budget

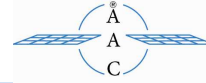

- **Spacecraft**
 - Wet mass, 9937 gram (incl. 20% margin)
 - Dry mass, 9073 gram (incl. 20% margin)
 - Dry mass, 7561 gram (excl. margin)

- Host docking I/F 2000 gram (incl. 20% margin)

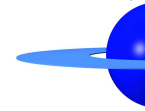

Power Budget

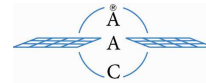

Option	MODE, All values in W, Margin 20%											
	Standby			Safe			Precision			Nominal		
	Default	Margin	Total	Default	Margin	Total	Default	Margin	Total	Default	Margin	Total
No TRX	9.5	1.9	11.4	16.6	3.32	19.92	33.85	6.77	40.62	27.1	5.42	32.52
TRX	19.5	3.9	23.4	26.6	5.32	31.92	43.85	8.77	52.62	37.1	7.42	44.52

Solar Power ~64 W

Batteries

- Sony Hard carbon 18650 (Li-Ion)
- BOL, 173 Whrs
- EOL, 156 Whrs

Battery time, 14 hours (safe mode).

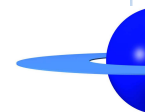

Link Budget

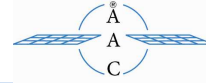

- Uplink
 - 14.5 kB/s (116 kbit/s)
 - Spacecraft receiver <0.5 W
 - 3 m parabola antenna
 - QPSK
- Downlink
 - 131 kB/s (1 Mbit/s)
 - Spacecraft transmitter 10 W
 - 2 W RF out
 - GMSK
 - Distance 1400 km

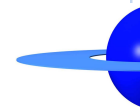

Avionics Block Diagram

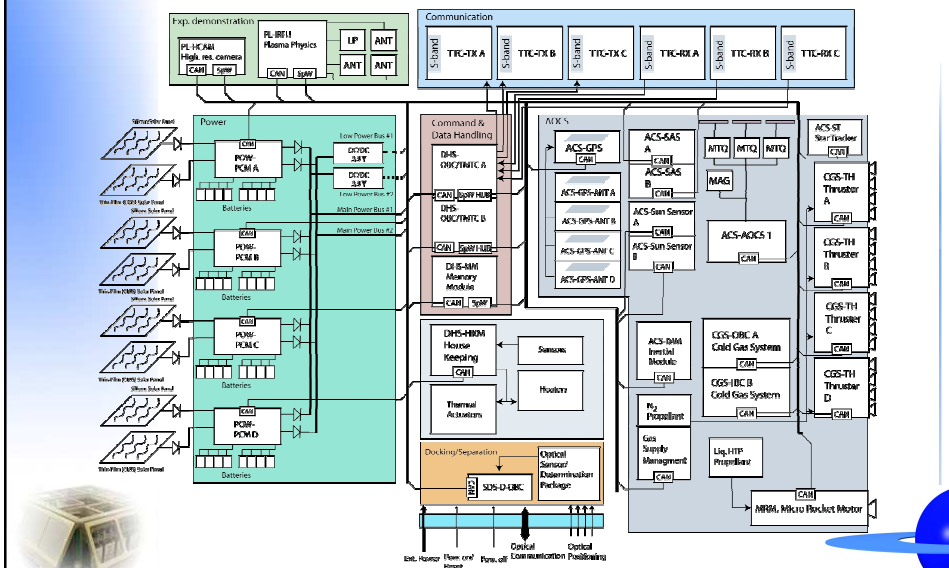
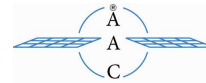

Electrical Design

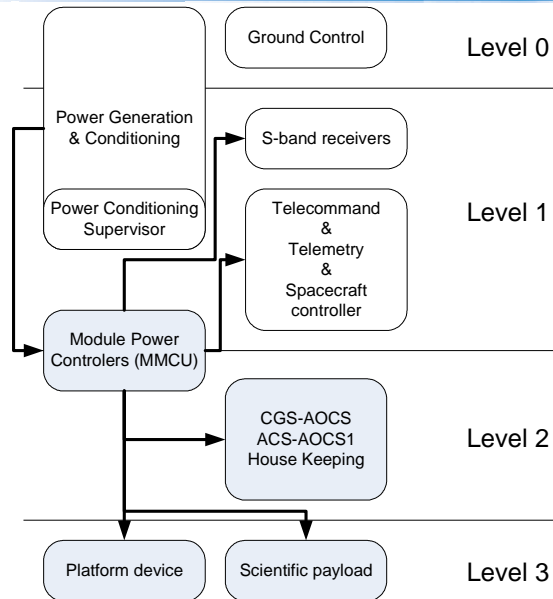
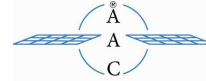

Power System Hierarchy

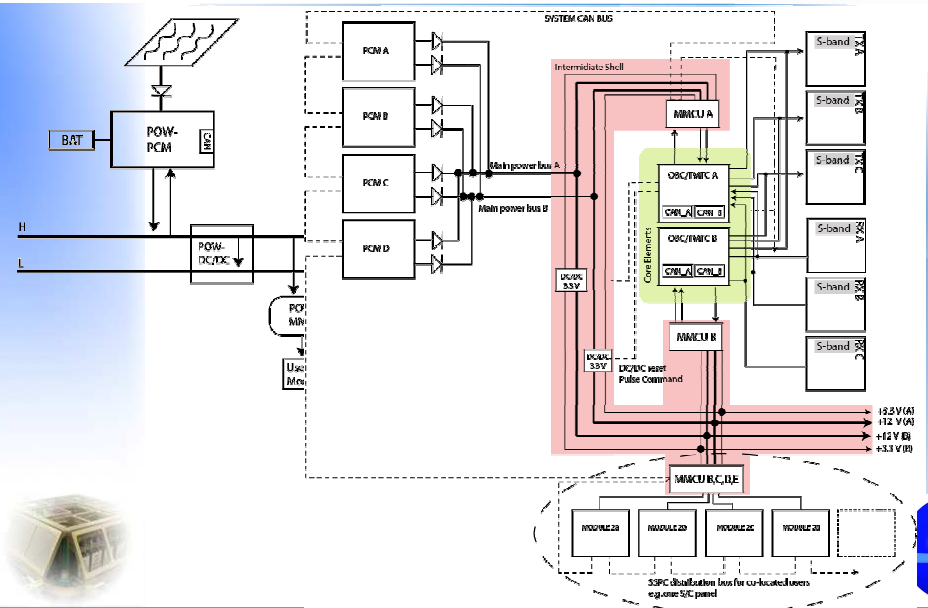

Electrical Redundancy

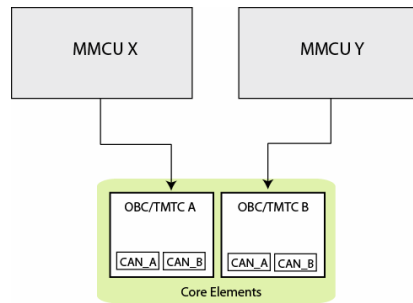
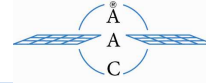

Data distribution

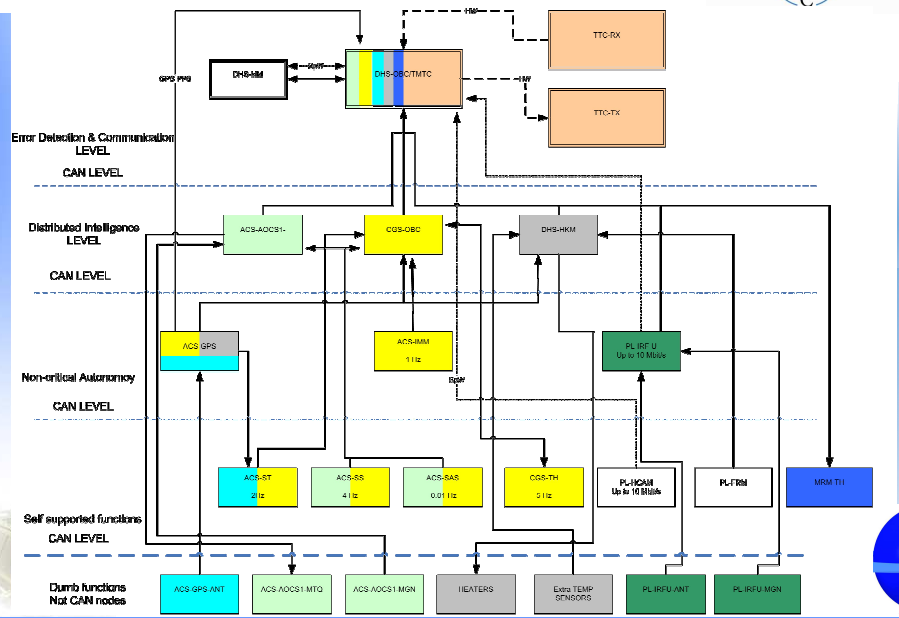

General S/C I/F Module

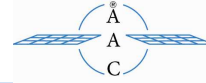

- CAN & SpaceWire Interface Module (CSIM)
 - Standardized user interface

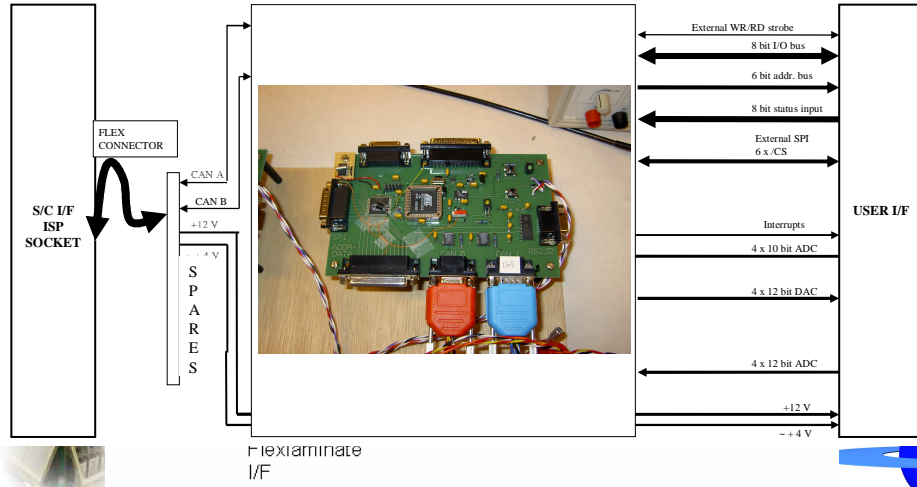

S/C communication bus test system, CSIM

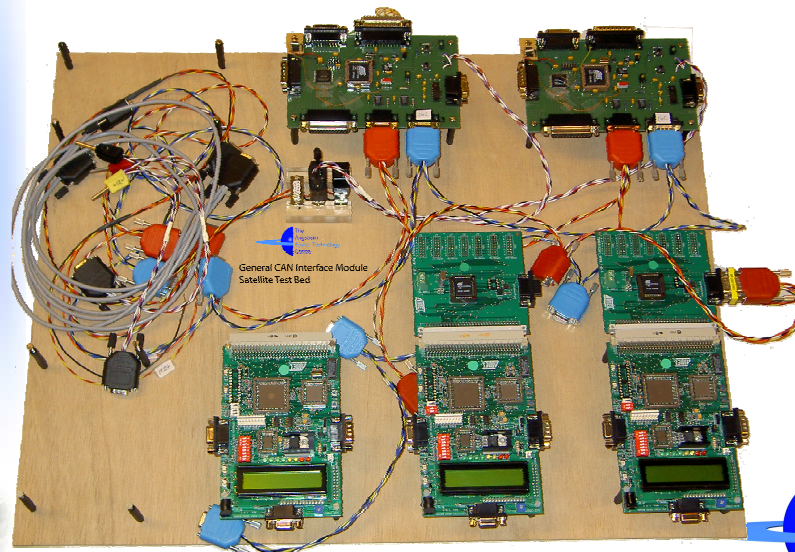
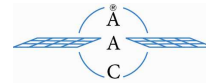

Data bus definition

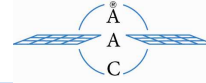

- 28 modules using CSIM
- 5 modules using CAN, SpaceWire in dedicated FPGA
- Group addressing to reduce bus latency and traffic
- Local 48 bit SCET
- CAN bus load simulated by KTH (MDA) to 27% with all systems going (worst case)

L	Originator								Group								Destination								Message Type								P
28	27	26	25	24	23	22	21	20	19	18	17	16	15	14	13	12	11	10	9	8	7	6	5	4	3	2	1	0					



Thermal Control



- Performed by Swedish Space Corporation (SSC) with inputs from ÅSTC using THERMICA

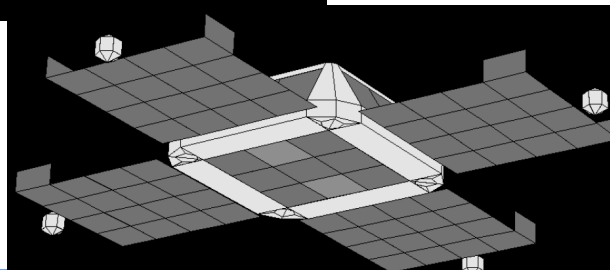
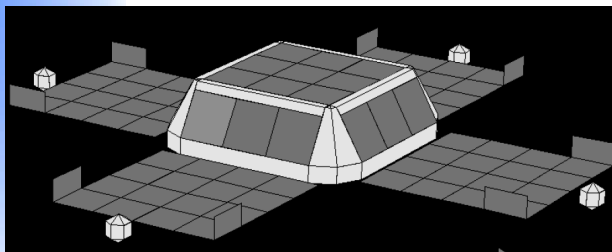

Thermal Control (2)

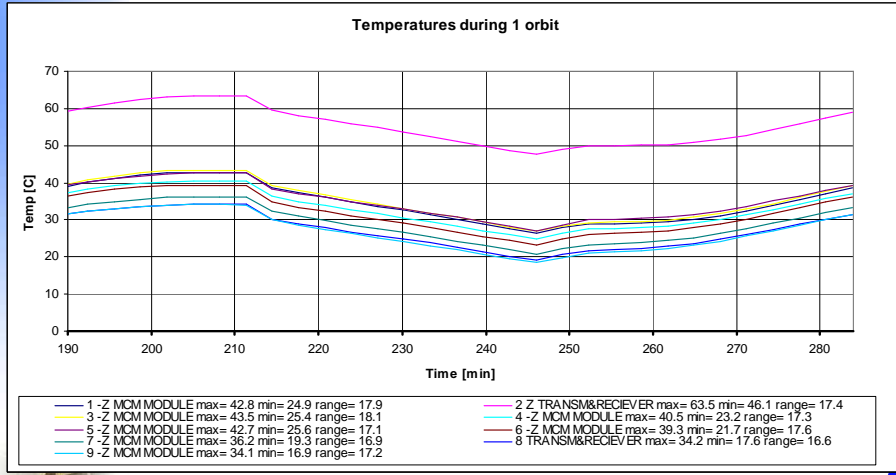
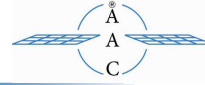

Telemetry, tracking & Control

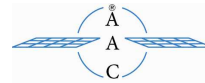

- Distributed s-band communication architecture

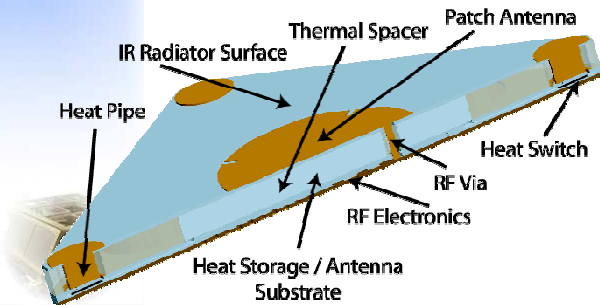
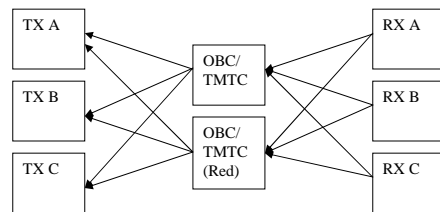

Cold Gas Micro Thrusters

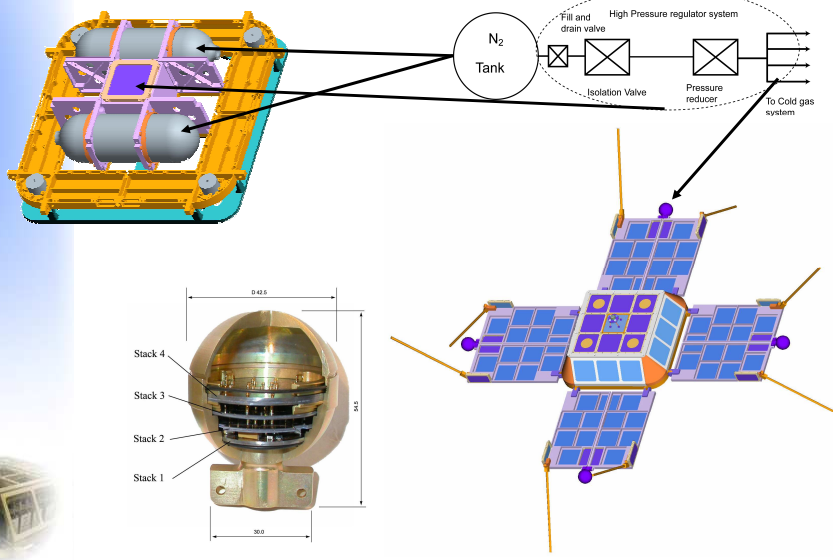

Ångström Aerospace Corporation

www.aerospace.com

Sida 23

Micro Rocket Motor

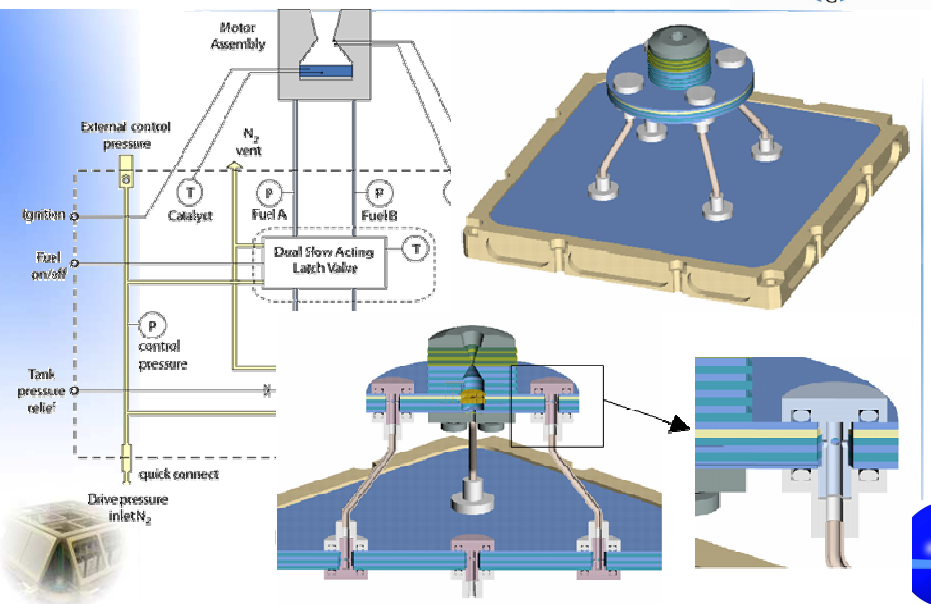
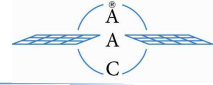

Ångström Aerospace Corporation

www.aerospace.com

Sida 24

3D-Sun Acquisition Sensor

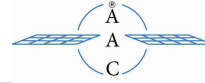

- Power: 100 mW
- 0-90 deg elevation
- 0-360 deg azimuth

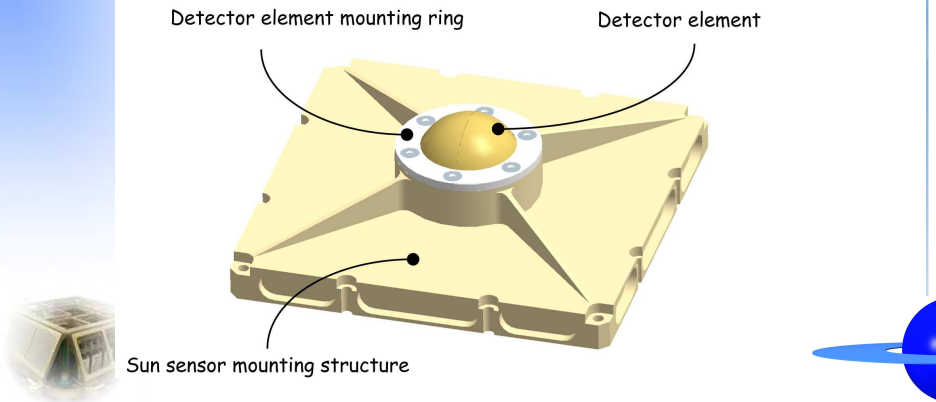

Ångström Aerospace Corporation

www.aerospace.com

Sida 25

Silicon Solar Cells

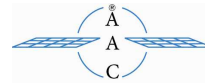

- Total Power 64 W, 16 W per panel
- Estimated efficiency, 16%

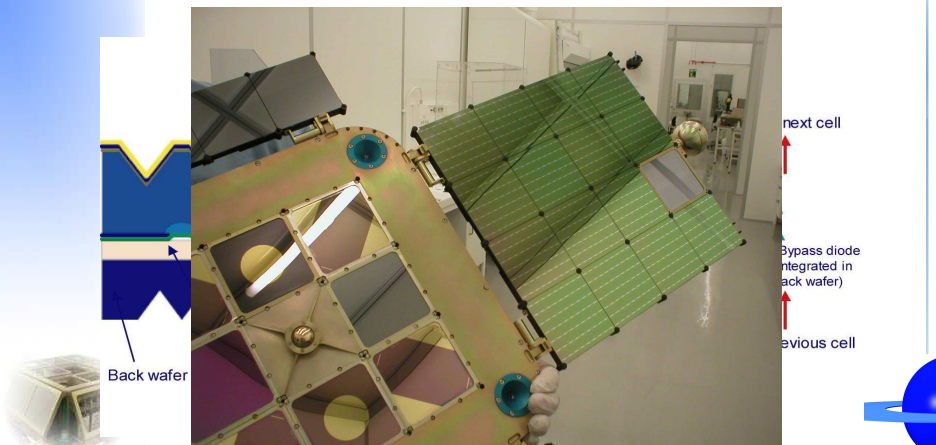

Ångström Aerospace Corporation

www.aerospace.com

Sida 26

GPS Antenna design

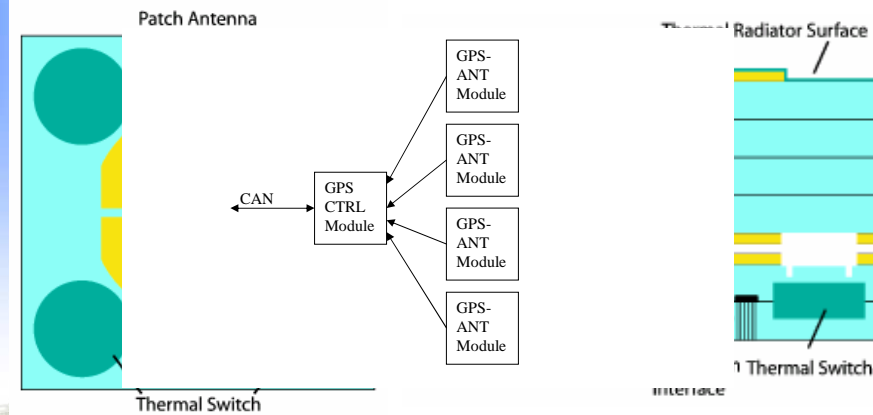
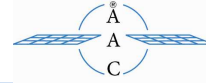

Separation & Docking (SDS)

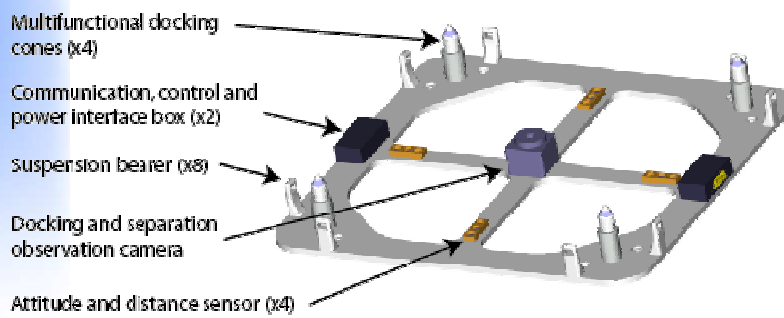

Structure (STR)

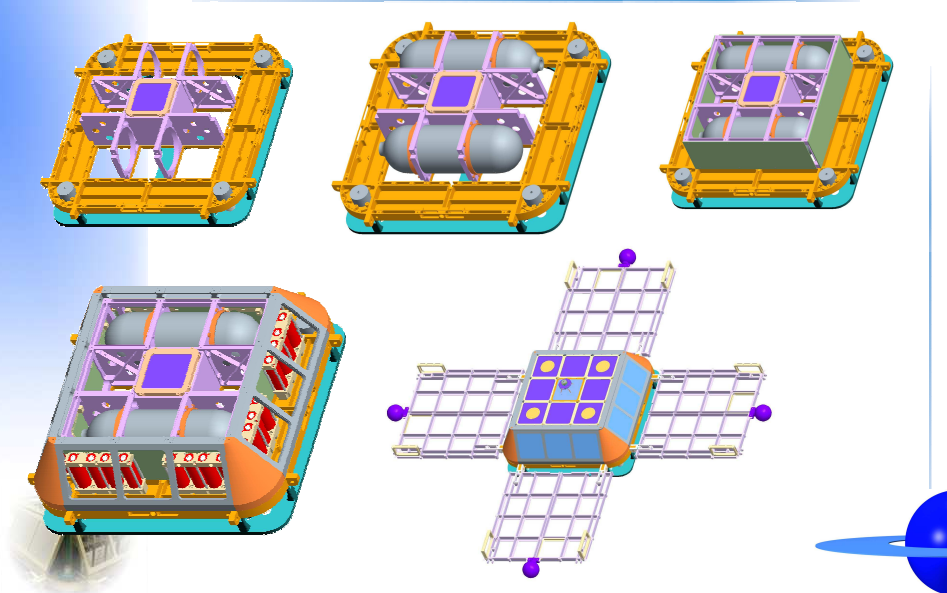
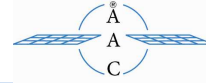

Ångström Aerospace Corporation

www.aerospace.com

Sida 29

STR Module Tests - setup

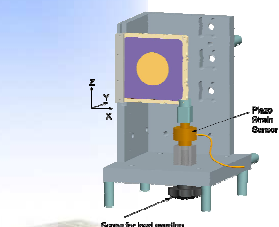
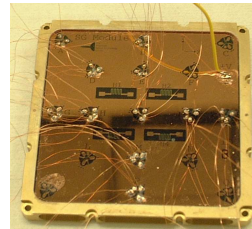
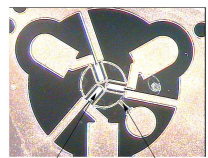
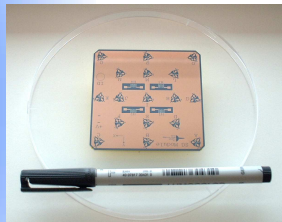
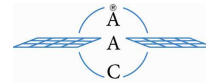

Shearing

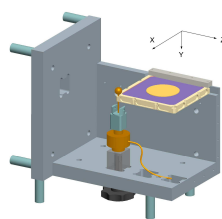

Warping

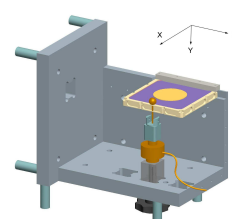

Bending

Ångström Aerospace Corporation

www.aerospace.com

Sida 30

STR Module Tests - sim

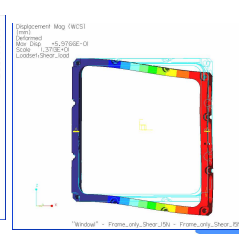
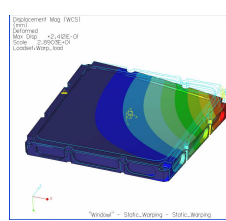
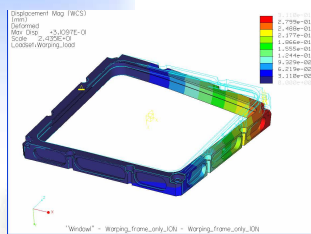
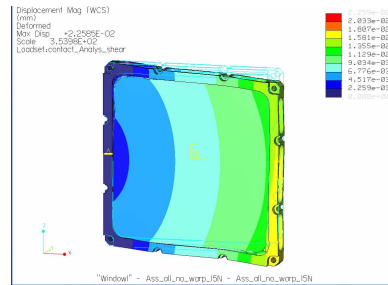
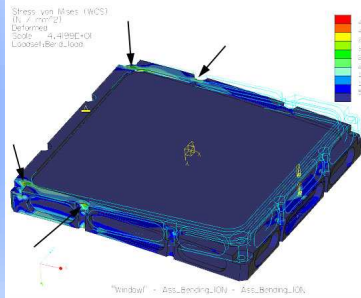
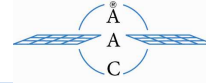

STR Module Tests - Results

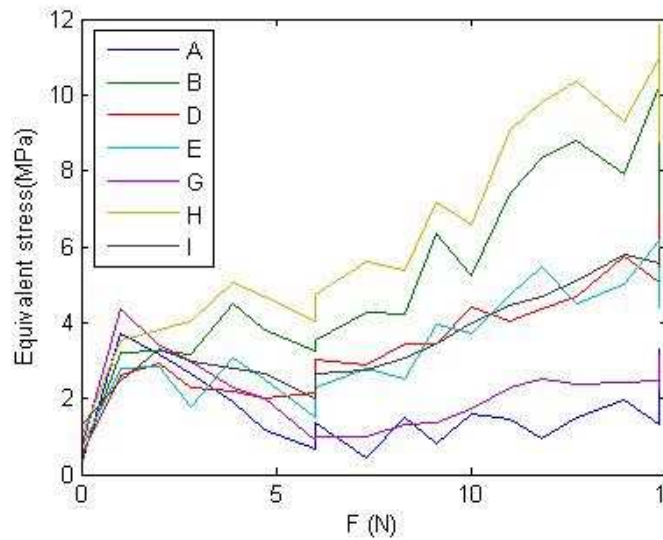
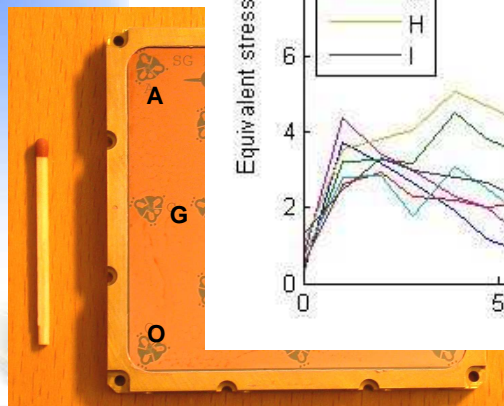

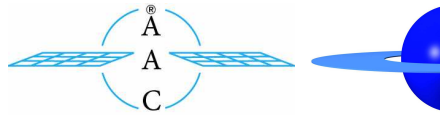

www.aaerospace.com

Ångström Aerospace Corporation (ÅAC)

Contact information:

Fredrik Bruhn, CEO

Ångström Aerospace Corporation, Dag Hammarskjölds väg 54, SE-751 83 Uppsala, Sweden

Mobile: +46 707 83 32 15, E-mail: fredrik.bruhn@aaerospace.com