



europaean space agency
agence spatiale européenne

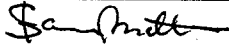
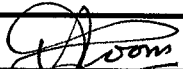

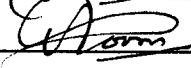
Pages 1 to 41

**CONNECTORS, ELECTRICAL, RECTANGULAR,
NON-REMOVABLE SOLDER BUCKET, PCB AND
WIRE-WRAP CONTACTS AND
REMOVABLE COAXIAL AND
POWER CONTACTS,
BASED ON TYPE D*M**

ESA/SCC Detail Specification No. 3401/001



**space components
coordination group**

Issue/Rev.	Date	Approved by	
		SCCG Chairman	ESA Director General or his Deputy
Issue 7	May 1998		
Revision 'A'	February 2000		

**DOCUMENTATION CHANGE NOTICE**

Rev. Letter	Rev. Date	Reference	CHANGE Item	Approved DCR No.
		This Issue supersedes Issue 6 and incorporates all modifications defined in Revision 'A' to Issue 6 and the changes agreed by the following DCRs:-		
		Cover page		None
		DCN		None
		Para. 2	: Items (e), (f), (g), (h) and (j) deleted and (i) renumbered	221433
		Table 1(a)	: Shell Sizes: "Variant 01" added to existing values and "Variant 02" information added	221433
			: Contact Types: New codes and Notes 7 to 9 added	221433/ 23890
		Table 1(b)	: No. 1, Gauge 20 contacts identified as "Variant 01" and Gauge 22 contact information added	221433
			: No. 2, Gauge 22 contact information added	221433
		Figure 1	: Voltage curve for Gauge 22 contacts added	221433
		Figure 2(a)	: All Shell Sizes: New Subtitle added and "Floating Mount" diagrams moved to a separate page	221433
			: Shell Size E: In the Table, "N", "P" and "ØR" deleted and "G" and "ØZ" amended	221433
			: Shell Sizes A, B, C and D: In the Table, "N", "P" and "ØR" deleted and "ØZ" amended	221433
			: Shell Size A: In Detail A, "(5)" added to dimension "W"	23890
		Figure 2(b)	: Floating Mount and Captive Nut: New page added	221433
			: Standard Contact Arrangements identified as Variant 01 and Variant 02 High Density Contact Arrangements added	221433
		Figure 2(c)	: Mixed Contact Arrangements identified as Variant 01	221433
			: Gauge 20 Solder Bucket Contacts: Drawing amended and Note 5 added	221433
			: Code OL3: Drawing amended and Code "Z" details and Notes 5 to 8 added	221433
			: Code OL3: Gauge 22 contacts, new page added	221433/ 23890
			: Codes 1AON/1BON, Sizes E to C : Details for "2AON/2BON", Pitch and new Notes 5 to 9 added	221443/ 23890
			: Note 4 amended	221433
			: Codes 1AON/1BON, Size D: Details for "2AON/2BON", Pitch and new Notes 4 to 8 added	221433/ 23890
			: Notes 2 and 3 amended and 4 deleted	221433
			: Codes 1A7N to 1B9N, Sizes E to C: Details for "2A7N to 2B9N" and new Notes 5 to 10 added	221433/ 23890
			: Notes 2 to 4 amended	221433
			: Codes 1A7N to 1B9N, Size D : Details for "2A7N to "2B9N" and Notes 5 to 10 added	221433/ 23890
			: Note 2 amended	221433
			: Codes 1CON/1DON, new page added	221433/ 23890
			: Codes 1C7N/1C9N, new page added	221433/ 23890
			: Codes 1D7N/1D9N, new page added	221433/ 23890



DOCUMENTATION CHANGE NOTICE

Rev. Letter	Rev. Date	Reference	CHANGE Item	Approved DCR No.
		Figure 2(c)	: Code F179A, Drawing amended and Pitch added	221433/ 23890
		Para. 4.2.4	: (b) "and 22" added after "20" in the text	221433
		Para. 4.3.1	: Second sentence added	221433
		Para. 4.3.3	: In the Table, existing values identified as "Gauge 20" and "Gauge 22" information added	221433
		Para. 4.3.4	: In the first sentence, "and 22" added after "20"	221433
		Para. 4.3.9	: In the Table, existing values identified as "Gauge 20" and "Gauge 22" information added	221433
		Para. 4.3.10	: First sentence deleted and new first sentence and Table added	221433
		Para. 4.3.11	: First sentence deleted and new first sentence and Table added	221433
		Para. 4.4.1	: Text amended	221433
		Para. 4.4.2	: All after "resin" deleted	221433
		Para. 4.4.3	: Second sentence deleted and new sentence added	221433
		Para. 4.4.4	: In the first sentence, "and 22" added after "20"	221433
		Para. 4.4.6	: First sentence amended and second sentence added	221433
		Para. 4.5.3	: In Type Variant, "Note 1" replaced by "Table 1(a)"	221433
			: Note deleted	221433
		Para. 4.5.4	: In the coding, "(Table 1(a))" added to "Contact Termination"	221433
		Para. 4.5.4.4	: New first sentence added	221433
		Para. 4.5.4.5	: In the Table, new codes "15", "26", "44", "62" and "78" added	221433
		Para. 4.5.4.7	: In the Table, "NMA" deleted and "(1)" added to "NMB"	221433
			: Note 1 added	221433
		Para. 4.5.4.8	: Text amended, Table deleted and existing Note 1 included as part of the text	221433/ 23890
		Table 2	: Items 4 and 5 amended	221433
			: Note 1 amended	221433
'A'	Feb. '00	P1.	Cover page	None
		P2A.	DCN	None
		P5.	Para. 2 : Items (f) and (g) added	221544
		P32.	Para. 4.4.2 : Text extended	221544
			Para. 4.4.3 : Existing text deleted and new text added	221544



TABLE OF CONTENTS

	<u>Page</u>
1. <u>GENERAL</u>	5
1.1 Scope	5
1.2 Range of Components	5
1.3 Maximum Ratings	5
1.4 Parameter Derating Information	5
1.5 Physical Dimensions	5
2. <u>APPLICABLE DOCUMENTS</u>	5
3. <u>TERMS, DEFINITIONS, ABBREVIATIONS, SYMBOLS AND UNITS</u>	5
4. <u>REQUIREMENTS</u>	30
4.1 General	30
4.2 Deviations from Generic Specification	30
4.2.1 Deviations from Special In-process Controls	30
4.2.2 Deviations from Final Production Tests	30
4.2.3 Deviations from Burn-in and Electrical Measurements	30
4.2.4 Deviations from Qualification Tests	30
4.2.5 Deviations from Lot Acceptance Tests	30
4.3 Mechanical Requirements	30
4.3.1 Dimension Check	30
4.3.2 Weight	30
4.3.3 Contact Capability	31
4.3.4 Contact Retention	31
4.3.5 Mating and Unmating Forces	31
4.3.6 Insert Retention	31
4.3.7 Jackscrew Retention	31
4.3.8 Contact Insertion and Withdrawal Forces	31
4.3.9 Engagement and Separation Forces	31
4.3.10 Oversize Pin Exclusion	32
4.3.11 Probe Damage	32
4.3.12 Solderability	32
4.4 Materials and Finishes	32
4.4.1 Shells	32
4.4.2 Inserts	32
4.4.3 Contacts	32
4.4.4 Contact Retaining Clip	32
4.4.5 Guiding and Locking Devices	32
4.4.6 Magnetism Level	33
4.5 Marking	33
4.5.1 General	33
4.5.2 Contact Position	33
4.5.3 The SCC Component Number	33
4.5.4 Characteristics	34
4.5.5 Traceability Information	36
4.6 Electrical Measurements	36
4.6.1 Electrical Measurements at Room Temperature	36
4.6.2 Electrical Measurements at High and Low Temperatures	36
4.6.3 Circuit for Electrical Measurements	36
4.7 Burn-in and Electrical Measurements	36



	<u>Page</u>
4.8 Environmental and Endurance Tests	38
4.8.1 Measurements and Inspections on Completion of Environmental Tests	38
4.8.2 Measurements and Inspections at Intermediate Points during Endurance Tests	38
4.8.3 Measurements and Inspections on Completion of Endurance Tests	38
4.8.4 Conditions for Operating Life Test	38
4.8.5 Electrical Circuits for Operating Life Test	38
4.8.6 Conditions for High Temperature Storage Test	38

TABLES

1(a) Range of Components	6
1(b) Maximum Ratings	7
2 Electrical Measurements at Room Temperature	37
3 Not Applicable	
4 Not Applicable	
5 Not Applicable	
6 Measurements and Inspections on Completion of Environmental and Endurance Testing	39

FIGURES

1 Parameter Derating Information	8
2 Physical Dimensions	9
2(a) Receptacles and Plugs	9
2(b) Contact Arrangements	15
2(c) Rear End	17

APPENDICES (Applicable to specific Manufacturers only)

None.

**1. GENERAL****1.1 SCOPE**

This specification details the ratings, physical and electrical characteristics, test and inspection data for Connectors, Electrical, Rectangular, Non-removable Solder Bucket, PCB and Wire-wrap Contacts and removable Coaxial and Power Contacts, based on type D*M. It shall be read in conjunction with:-

ESA/SCC Generic Specification No. 3401, Connectors, Electrical, Non-Filtered, Circular and Rectangular.

ESA/SCC Detail Specification No. 3401/004, Contacts, Coaxial, Crimp and Solder, for 3401/001 Connectors.

ESA/SCC Detail Specification No. 3401/022, Accessories for Rectangular Connectors 3401/001, 3401/002 and Connector Savers 3401/020.

ESA/SCC Detail Specification No. 3401/040, Contacts, Power, Crimp and Solder, for 3401/001 Connectors.

the requirements of which are supplemented herein.

1.2 RANGE OF COMPONENTS

The different sizes of the connectors and contact types specified herein, which are also covered by this specification, together with their mechanical characteristics, are given in Table 1(a).

1.3 MAXIMUM RATINGS

The maximum ratings, which shall not be exceeded at any time during use or storage, applicable to the connectors specified herein, are scheduled in Table 1(b).

1.4 PARAMETER DERATING INFORMATION

The applicable derating information for the connectors specified herein is shown in Figure 1.

1.5 PHYSICAL DIMENSIONS

The physical dimensions of the connectors specified herein are shown in Figure 2.

2. APPLICABLE DOCUMENTS

The following documents form part of this specification and shall be read in conjunction with it:-

- (a) ESA/SCC Generic Specification No. 3401 for Connectors, Electrical, Non-Filtered, Circular and Rectangular.
- (b) ESA/SCC Detail Specification No. 3401/004, Contacts, Coaxial, Crimp and Solder for 3401/001 Connectors.
- (c) ESA/SCC Detail Specification No. 3401/022, Accessories for Rectangular Connectors, 3401/001, 3401/002 and Connector Savers 3401/020.
- (d) ESA/SCC Detail Specification No. 3401/040, Contacts, Power, Crimp and Solder for 3401/001 Connectors.
- (e) MIL-C-24308, Rack and Panel Connectors, Miniature.
- (f) MIL-G-45204, Gold Plating, Electro-deposited.
- (g) MIL-C-14550, Copper Plating, Electro-deposited.

3. TERMS, DEFINITIONS, ABBREVIATIONS, SYMBOLS AND UNITS

For the purpose of this specification, the terms, definitions, abbreviations, symbols and units specified in ESA/SCC Basic Specification No. 21300 shall apply.

TABLE 1(a) - RANGE OF COMPONENTS

SHELL SIZES

VARIANT	SHELL SIZE (1)	MAX. WEIGHT (g) (2) (3)		MATING FORCE (N. max)	UNMATING FORCE	
		Male	Female		N. min	N. max
01 (Gauge 20 Contacts)	E	4.5	5.0	30	3.5	20
	A	5.5	7.0	50	4.5	34
	B	9.0	10.0	83	8.0	55
	C	12.5	13.5	123	11.0	83
	D	13.5	15	166	14.5	120
02 (Gauge 22 Contacts)	E	5.2	6.0	46	3.4	28
	A	7.4	8.0	77	4.5	46
	B	11	12	127	7.9	77
	C	15.6	17	177	11.3	109
	D	18.2	20	222	14.7	136

NOTES

1. See Figure 2(b).
2. Weights without contacts or accessories.
3. Connector weights shall be calculated from the number of contacts used, plus the weight of the power or coaxial contact given in ESA/SCC Detail Specification Nos. 3401/040 or 3401/004, plus the connector weight.

TABLE 1(a) - RANGE OF COMPONENTS (CONTD)

CONTACT TYPES

CONTACT CODES	CONTACT TYPES	Weight of Contacts (g)			
		Variant 01		Variant 02	
		Male	Female	Male	Female
– PCB Contacts (Ø) Tail 0.60 Tail 0.76	Gauge 20 solder bucket for wire sizes AWG 20 to 24	0.19	0.22	-	-
OL3 -	Straight PCB solder contact gauges 20 and 22	0.17	0.20	0.17	0.20
- Z	Straight PCB solder contact gauge 20	0.17	0.20	-	-
1AON 2AON	Gauge 20 90° PCB solder contact (2.54mm row spacing)	0.24(4)	0.29(4)	-	-
1BON 2BON	Gauge 20 90° PCB solder contact (2.84mm row spacing)	0.28(5)	0.34(5)	-	-
		0.32(6)	0.37(6)	-	-
1CON -	Gauge 22 90° PCB solder contact (1.98mm row spacing shell sizes E, A, B and C)	-	-	0.188	0.212
1DON -	Gauge 22 90° PCB solder contact (2.08mm row spacing shell size D)	-	-	(7)	(7)
1(8)7N 2(9)7N	Gauge 20 90° PCB solder contact equipped with 90° bracket and screw locks 4-40 (2)	0.24(4)	0.29(4)	-	-
1(8)9N 2(9)9N	Gauge 20 90° PCB solder contact equipped with 90° bracket and screw locks M3 (2)	0.28(5)	0.34(5)	-	-
		0.32(6)	0.37(6)	-	-
F179A	Gauge 20 wire-wrap contacts for wire sizes AWG 26 to 30	0.28	0.34	-	-
-	Power and coaxial contacts (See relevant Detail Specification)	(3)	(3)	-	-

NOTES

1. See Figure 2(c).
2. Weight of brackets and nuts: 3.5g.
3. See Figure 2(b). Power and coaxial contacts shall be ordered separately in accordance with ESA/SCC Detail Specification Nos. 3401/040 and 3401/004 respectively.
4. Weight of contact in row nearest to connector mounting plane (Ref. Plane).
5. Weight of contact in row farthest from connector mounting plane (Ref. Plane), except for size D where it is the middle row.
6. For size D only, weight of contact in row farthest from connector mounting plane (Ref. Plane).
7. Average weight.
8. A, B, C or D, as applicable.
9. A or B, as applicable.

**TABLE 1(b) - MAXIMUM RATINGS**

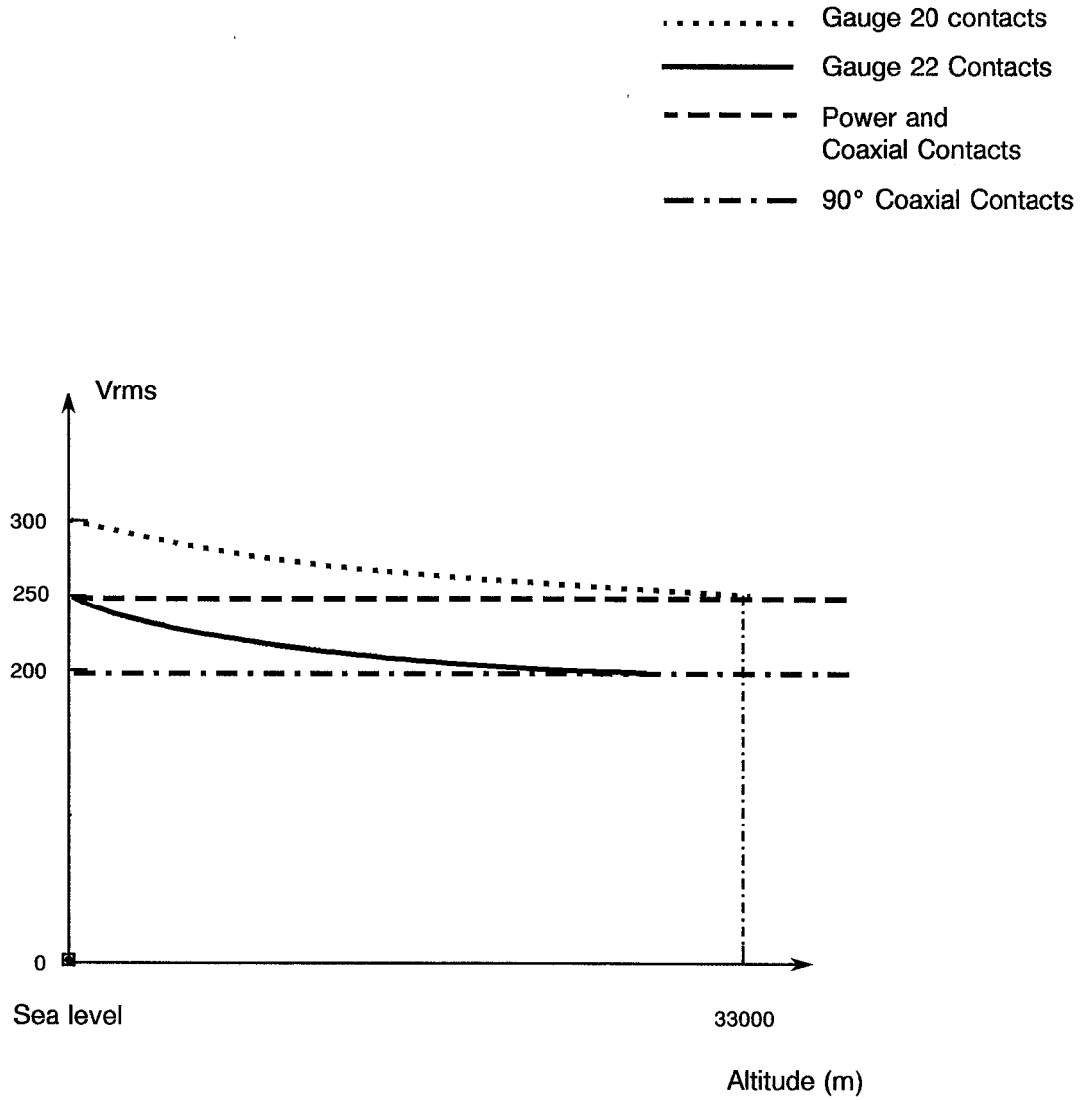
No.	CHARACTERISTICS	SYMBOL	MAXIMUM RATING	UNIT	REMARKS
1	Working Voltage Sea Level - Gauge 20 Contacts (Var. 01) - Gauge 22 Contacts (Var. 02) - Power, High Voltage and Straight Coaxial Contacts - 90° Coaxial Contacts	U_R	300 250 250 200	Vrms	Note 1
2	Rated Current - Gauge 20 and Coaxial Centre Contacts - Gauge 22 (PCB Contacts) - Power Contacts	I_R	7.5 3.0 40	A	-
3	Operating Temperature Range	T_{op}	-55 to +125	°C	T_{amb}
4	Storage Temperature Range	T_{stg}	-65 to +125	°C	
5	Soldering Temperature	T_{sol}	+260	°C	Note 2

NOTES

1. Between contact and shell.
2. Duration 10 seconds maximum and the same contact shall not be resoldered until 3 minutes have elapsed.



FIGURE 1 - PARAMETER DERATING INFORMATION



Working Voltage versus Altitude

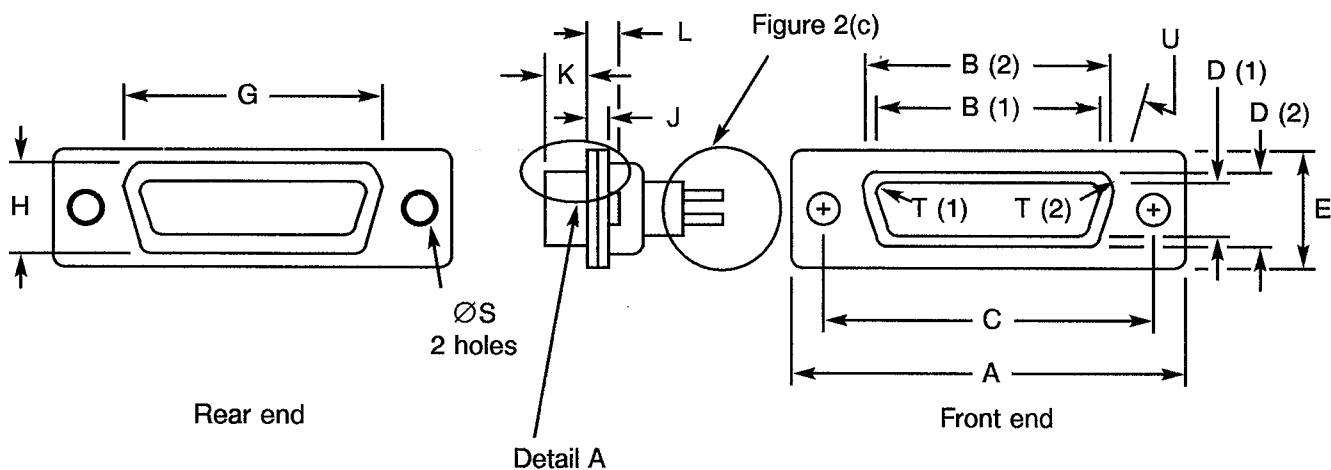


FIGURE 2 - PHYSICAL DIMENSIONS

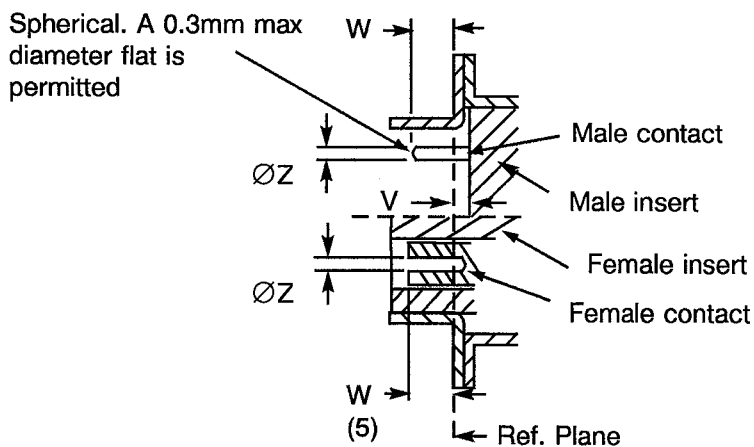
FIGURE 2(a) - RECEPTACLES AND PLUGS

SHELL SIZE E

Standard Mounting Holes



DETAIL A



Contact Type	Symbol/Dim.	A	B	C	D	E	G	H	J	K	L	ØS	T	U	V	W	ØZ	
																	V.01	V.02
Male	min.	30.43	16.79	24.87	8.23	12.17	19.02	10.46	0.51	5.82	0.89	2.92	2.59	9.0	0	4.03	0.99	0.75
	max.	31.26	17.04	25.12	8.48	12.93	19.53	10.97	1.02	6.13	1.52	3.20	2.69	11.0	0.4	-	1.04	0.77
Female	min.	30.43	16.21	24.87	7.77	12.17	19.02	10.46	0.51	5.87	0.89	2.92	2.46	9.0	-	3.63	1.07	0.89
	max.	31.26	16.46	25.12	8.03	12.93	19.53	10.97	1.02	6.30	1.52	3.20	2.62	11.0	-	-	1.14	0.95

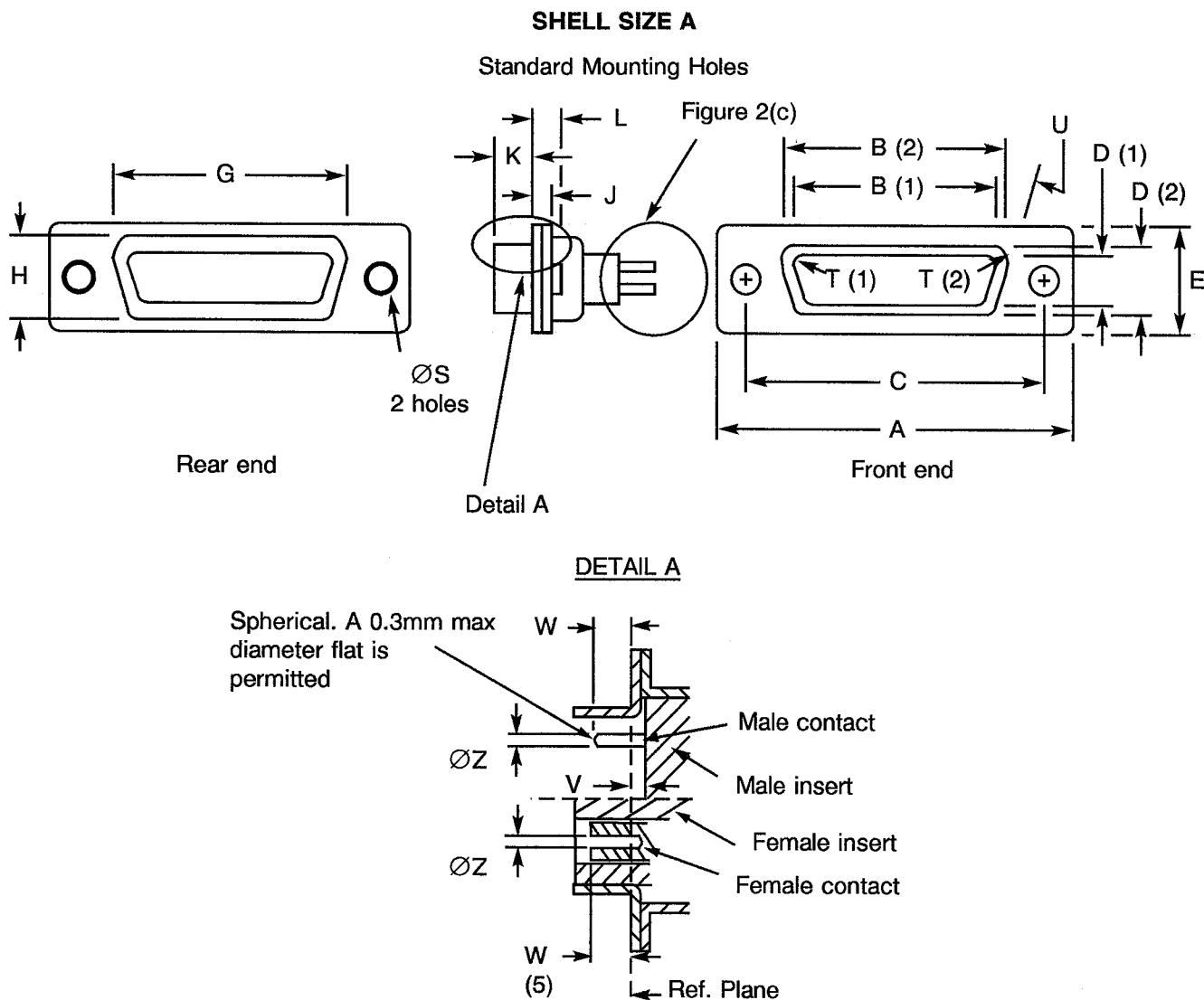
NOTES

1. Inside dimension for connectors with male contacts.
2. Outside dimension for connectors with female contacts.
3. All dimensions are in millimetres (angles in degrees).
4. Underlined dimensions, in table, are critical to ensure intermateability.
5. Electrical contact position in female contact.



FIGURE 2 - PHYSICAL DIMENSIONS (CONTINUED)

FIGURE 2(a) - RECEPTACLES AND PLUGS



Contact type	Symbol/ Dim.	A	<u>B</u>	<u>C</u>	<u>D</u>	E	G	H	J	<u>K</u>	L	ØS	<u>T</u>	<u>U</u> °	V	W	ØZ	
			V.01	V.02														
Male	min.	<u>38.76</u>	25.12	33.20	8.23	12.17	27.25	10.46	0.51	5.82	0.89	2.92	2.59	9.0	0	4.03	0.99	0.75
	max.	39.52	25.37	33.45	8.48	12.93	27.76	10.97	1.02	6.13	1.52	3.20	2.69	11.0	0.4	-	1.04	0.77
Female	min.	<u>38.76</u>	24.54	33.20	7.77	12.17	27.25	10.46	0.51	5.87	0.89	2.92	2.46	9.0	-	3.63	1.07	0.89
	max.	39.52	24.79	33.45	8.03	12.93	27.76	10.97	1.02	6.30	1.52	3.20	2.62	11.0	-	-	1.14	0.95

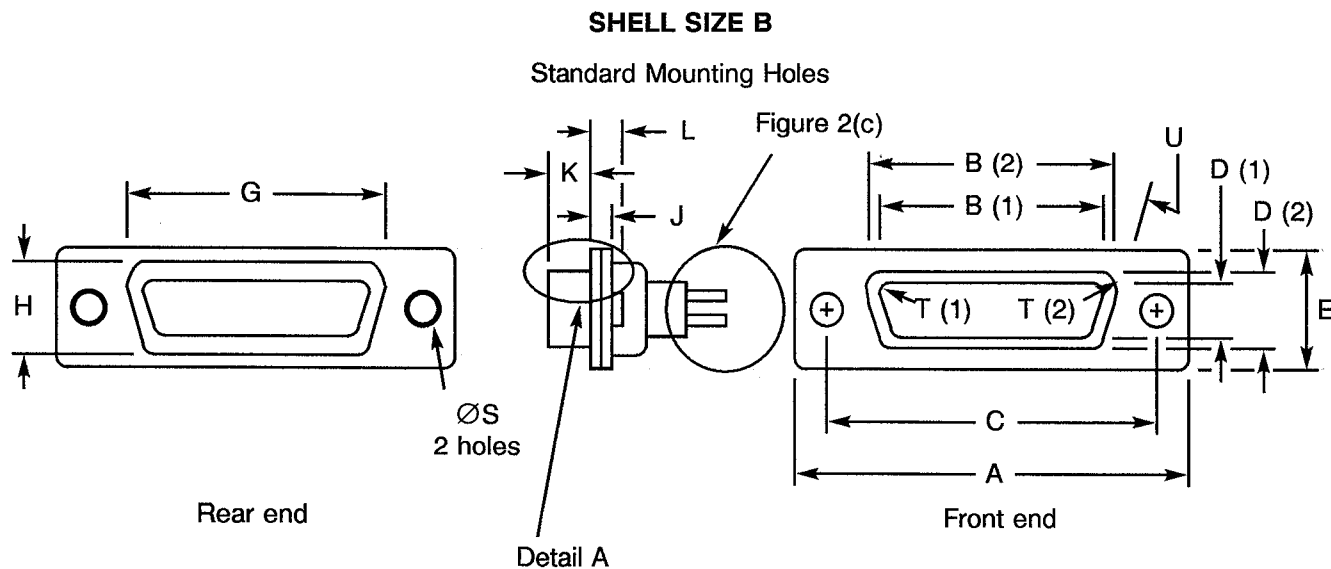
NOTES

1. Inside dimension for connectors with male contacts.
2. Outside dimension for connectors with female contacts.
3. All dimensions are in millimetres (angles in degrees).
4. Underlined dimensions, in table, are critical to ensure intermateability.
5. Electrical contact position in female contact.

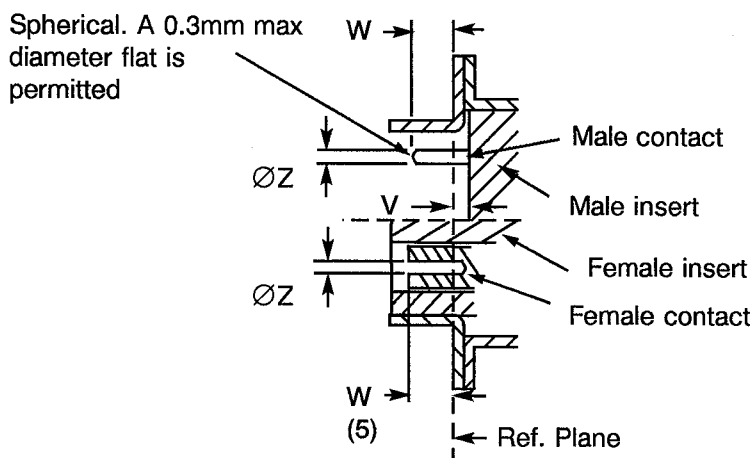


FIGURE 2 - PHYSICAL DIMENSIONS (CONTINUED)

FIGURE 2(a) - RECEPTACLES AND PLUGS



DETAIL A



Contact Type	Symbol/ Dim.	A	<u>B</u>	<u>C</u>	<u>D</u>	E	G	H	J	<u>K</u>	L	ØS	<u>T</u>	<u>U</u>	<u>V</u>	W	ØZ	
			V.01	V.02														
Male	min.	52.65	38.84	46.91	8.23	12.17	41.02	10.46	0.51	5.69	1.05	2.92	2.59	9.0	0	3.81	0.99	0.75
	max.	53.42	39.09	47.17	8.48	12.93	41.53	10.97	1.24	6.13	1.78	3.20	2.69	11.0	0.6	-	1.04	0.77
Female	min.	52.65	38.25	46.91	7.77	12.17	41.02	10.46	0.51	5.87	0.89	2.92	2.46	9.0	-	3.63	1.07	0.89
	max.	53.42	38.51	47.17	8.03	12.93	41.53	10.97	1.02	6.30	1.52	3.20	2.62	11.0	-	-	1.14	0.95

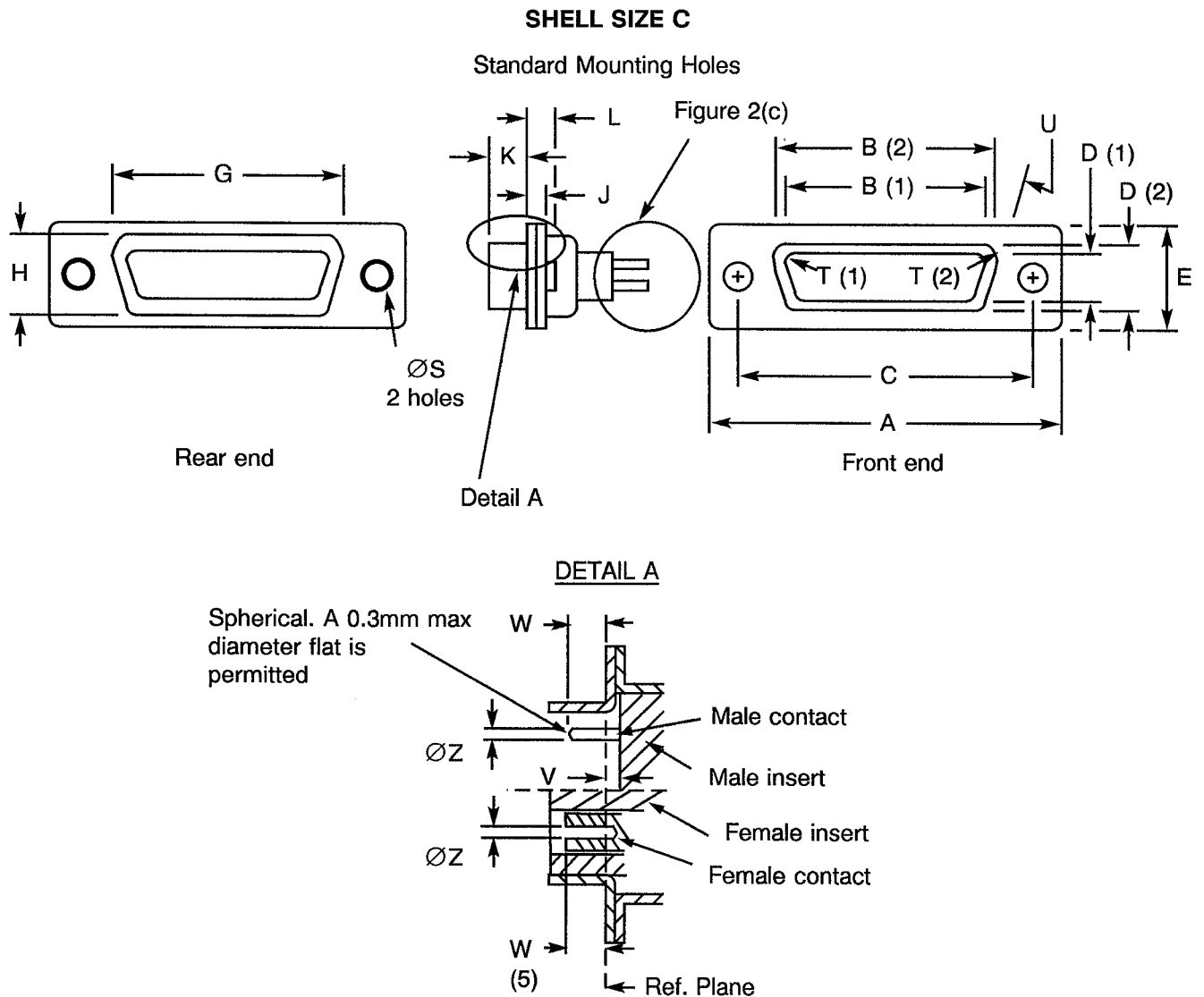
NOTES

1. Inside dimension for connectors with male contacts.
2. Outside dimension for connectors with female contacts.
3. All dimensions are in millimetres (angles in degrees).
4. Underlined dimensions, in table, are critical to ensure intermateability.
5. Electrical contact position in female contact.



FIGURE 2 - PHYSICAL DIMENSIONS (CONTINUED)

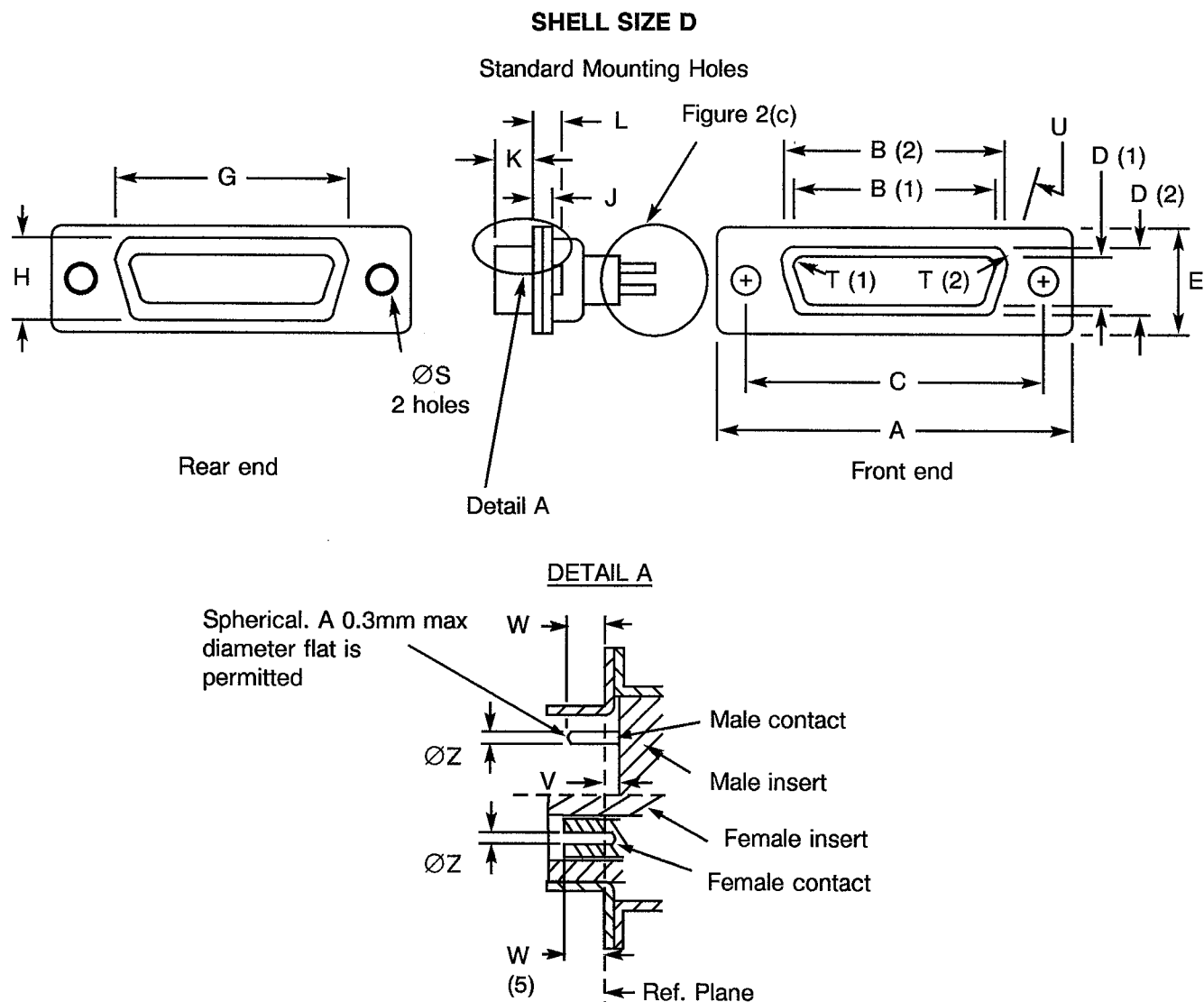
FIGURE 2(a) - RECEPTACLES AND PLUGS



Contact Type	Symbol/Dim.	A	<u>B</u>	<u>C</u>	<u>D</u>	E	G	H	J	<u>K</u>	L	ØS	I	<u>U</u>	V	W	ØZ	
																		V.01
Male	min.	68.94	55.30	63.37	8.23	12.17	57.45	10.46	0.51	5.69	1.05	2.92	2.59	9.0	0	3.81	0.99	0.75
	max.	69.70	55.55	63.63	8.48	12.93	57.96	10.97	1.24	6.13	1.78	3.20	2.69	11.0	0.6	-	1.04	0.77
Female	min.	68.94	54.71	63.37	7.77	12.17	57.45	10.46	0.51	5.87	0.89	2.92	2.46	9.0	-	3.63	1.07	0.89
	max.	69.70	54.97	63.63	8.03	12.93	57.96	10.97	1.02	6.30	1.52	3.20	2.62	11.0	-	-	1.14	0.95

NOTES

1. Inside dimension for connectors with male contacts.
2. Outside dimension for connectors with female contacts.
3. All dimensions are in millimetres (angles in degrees).
4. Underlined dimensions, in table, are critical to ensure intermateability.
5. Electrical contact position in female contact.

FIGURE 2 - PHYSICAL DIMENSIONS (CONTINUED)
FIGURE 2(a) - RECEPTACLES AND PLUGS


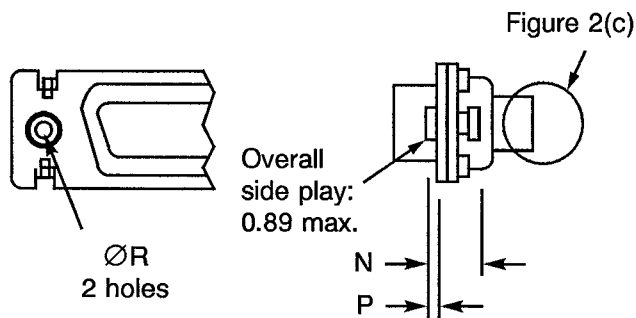
Contact Type	Symbol/Dim.	A	<u>B</u>	<u>C</u>	<u>D</u>	E	G	H	J	<u>K</u>	L	ØS	<u>T</u>	<u>U</u>	<u>V</u>	W	ØZ	
			V.01	V.02														
Male	min.	66.55	52.68	60.99	10.95	14.99	55.07	13.31	0.51	5.69	1.05	2.92	2.59	9.0	0	3.81	0.99	0.75
	max.	67.31	52.93	61.24	11.33	15.75	55.58	13.82	1.24	6.13	1.78	3.20	2.69	11.0	0.6	-	1.04	0.77
Female	min.	66.55	52.30	60.99	10.62	14.99	55.07	13.31	0.51	5.87	0.89	2.92	2.46	9.0	-	3.63	1.07	0.89
	max.	67.31	52.55	61.24	10.87	15.75	55.58	13.82	1.02	6.30	1.52	3.20	2.62	11.0	-	-	1.14	0.95

NOTES

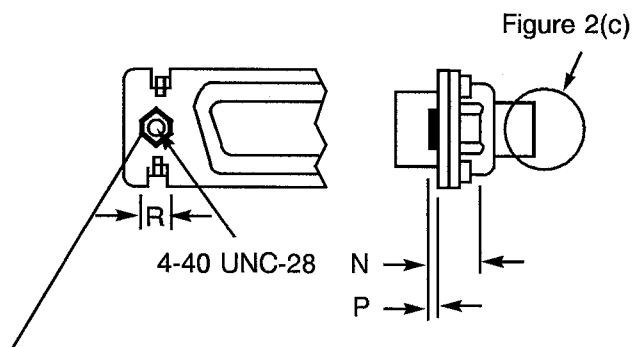
1. Inside dimension for connectors with male contacts.
2. Outside dimension for connectors with female contacts.
3. All dimensions are in millimetres (angles in degrees).
4. Underlined dimensions, in table, are critical to ensure intermateability.
5. Electrical contact position in female contact.

FIGURE 2 - PHYSICAL DIMENSIONS (CONTINUED)
FIGURE 2(a) - RECEPTACLES AND PLUGS
SHELL SIZE E, A, B, C and D

OTHER MOUNTING TYPES

FLOATING MOUNT - TYPE 'Y'


Contact Type	Symbol/Dim.	N	P	ØR
Male	Min.	2.4	0.76	2.2
	Max.	3.3	0.86	2.3
Female	Min.	2.4	0.76	2.2
	Max.	3.3	0.86	2.3

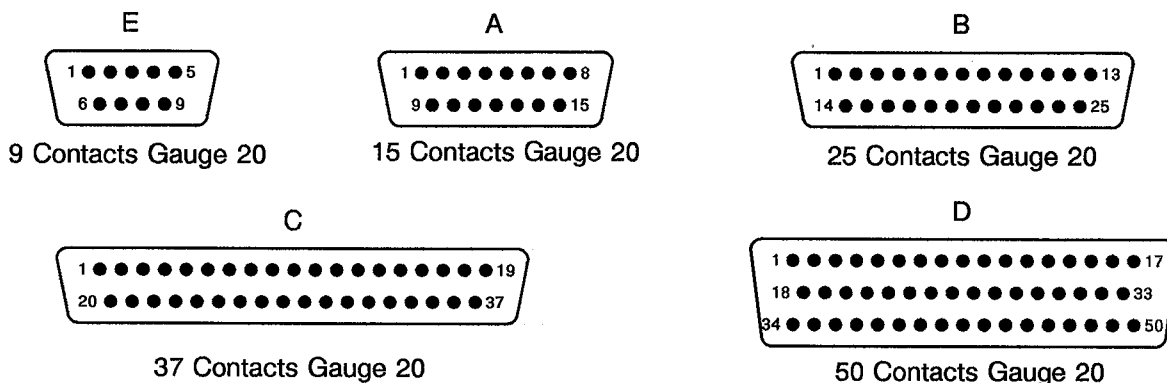
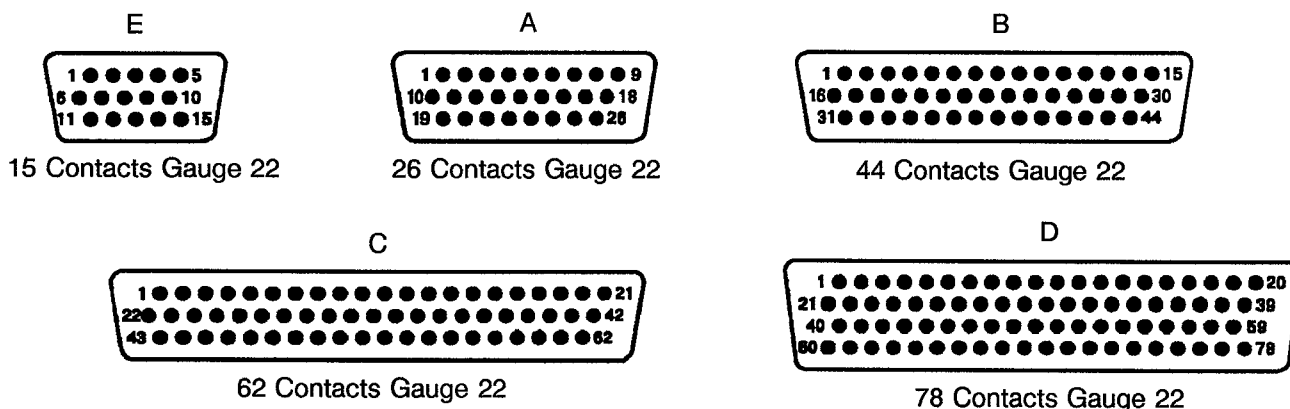
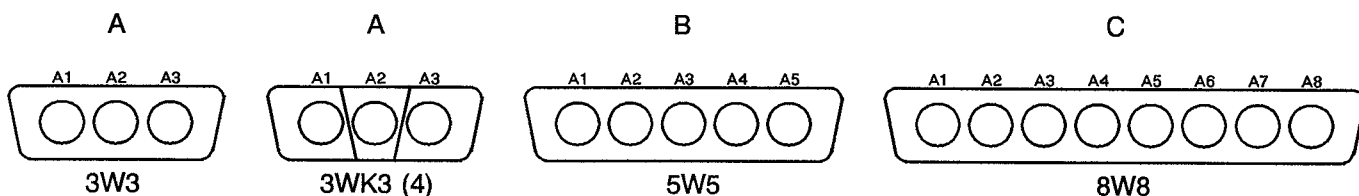
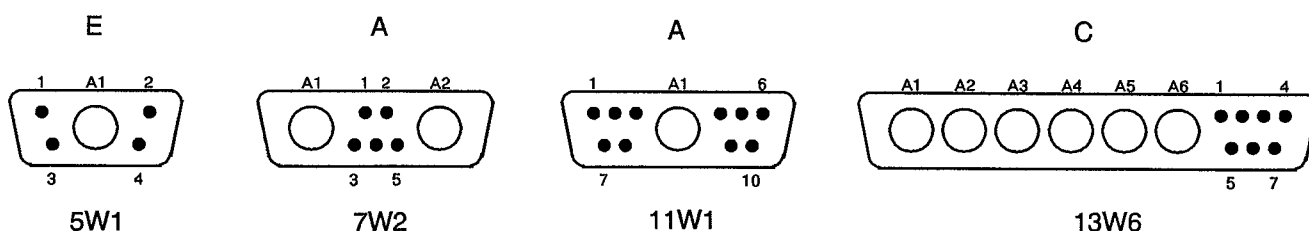
CAPTIVE NUT - TYPE 'E'


Contact Type	Symbol/Dim.	N	P	R
Male	Min.	3.4	0.2	4.3
	Max.	4.2	0.4	4.7
Female	Min.	3.4	0.2	4.3
	Max.	4.2	0.4	4.7

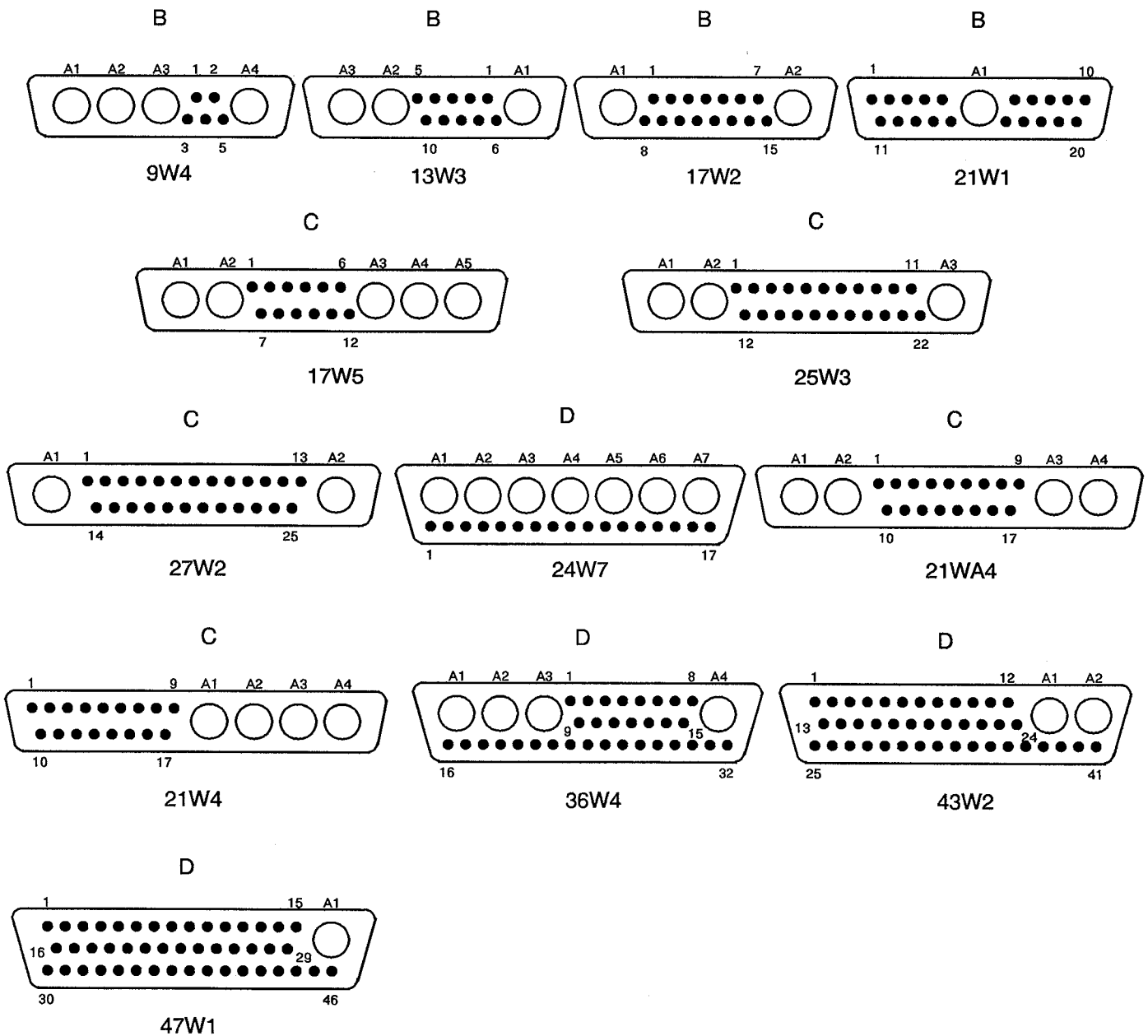
Maximum torque value = 5.5cm.da.N

NOTES

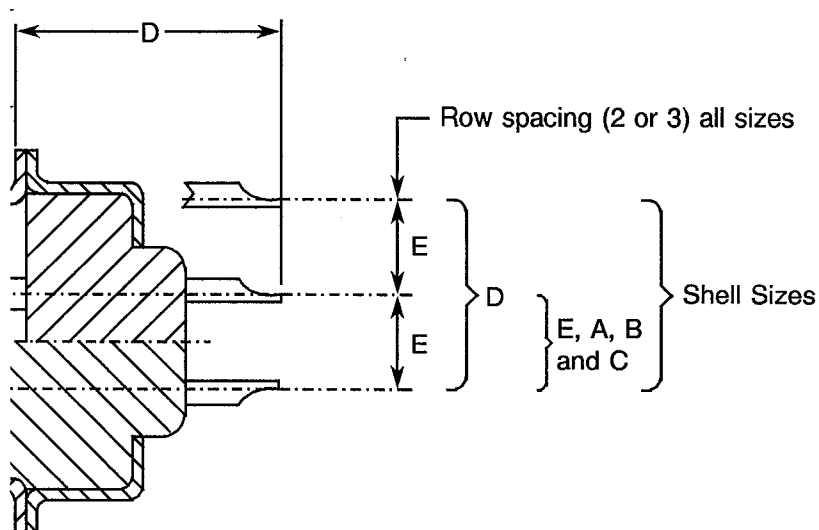
1. See Figure 2(a) for other dimensions.

FIGURE 2 - PHYSICAL DIMENSIONS (CONTINUED)
FIGURE 2(b) - CONTACT ARRANGEMENTS
(FRONT VIEW MALE INSERT)
VARIANT 01 - STANDARD CONTACT ARRANGEMENTS
FRONT VIEW MALE INSERT

VARIANT 02 - HIGH DENSITY CONTACT ARRANGEMENTS
FRONT VIEW MALE INSERT

POWER AND COAXIAL CONTACT ARRANGEMENTS FOR VARIANT 01 ONLY

MIXED CONTACT ARRANGEMENTS FOR VARIANT 01 ONLY


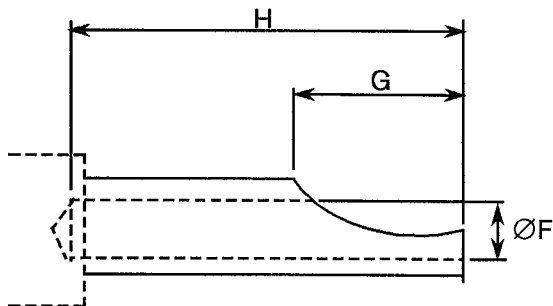
NOTES: See Page 16.

FIGURE 2 - PHYSICAL DIMENSIONS (CONTINUED)
FIGURE 2(b) - CONTACT ARRANGEMENTS (CONTINUED)
(FRONT VIEW MALE INSERT)
MIXED CONTACT ARRANGEMENTS FOR VARIANT 01 ONLY (CONTINUED)

NOTES

1. Contact locations are in conformity with MIL-C-24308 specification sheets and shall not be checked during procurement.
2. Both sides of the insert shall be marked with the minimum marking shown. Contact numbers are shown outside the inserts for readability.
3. See Para. 4.5 for definition of letters and numbers.
4. 3WK3 insulator with built-in keying (middle part recessed or protruding with respect to each side), to avoid mismounting (K = keyed).

FIGURE 2 - PHYSICAL DIMENSIONS (CONTINUED)
FIGURE 2(c) - REAR END
Gauge 20 Solder Bucket Contacts (CODE -)

Pitch between contacts

Connector shell sizes E and A: 2.74.
 Connector shell sizes B, C and D: 2.76.



Symbol/ Dim.	\underline{D} (2) (3)	\underline{D} (4)	E (5)	$\underline{\text{ØF}}$	G	H
min.	-	-	2.77	1.1	1.4	2.4
max.	10.71	10.91	2.91	1.15	2.5	-

NOTES

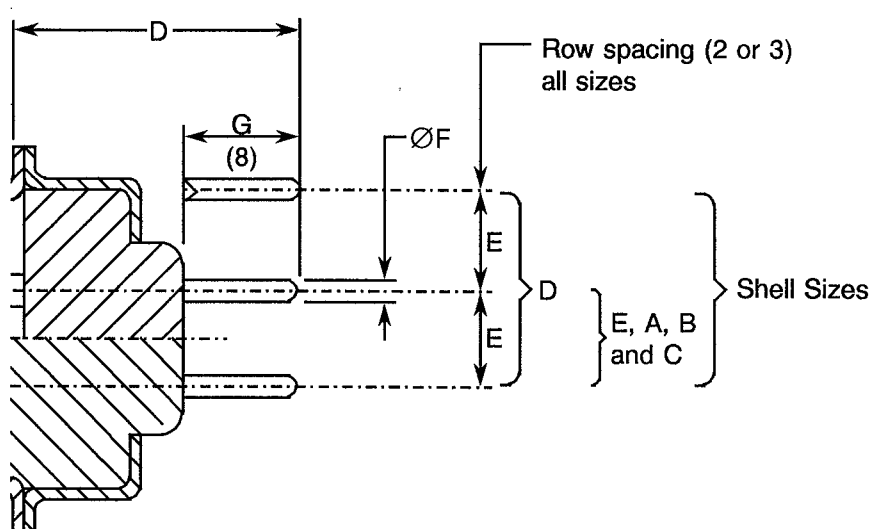
1. All dimensions are in mm.
2. Connectors equipped with female contacts all sizes.
3. Connectors equipped with male contacts sizes E and A.
4. Connectors equipped with male contacts sizes B, C and D.
5. Typical = 2.84.



FIGURE 2 - PHYSICAL DIMENSIONS (CONTINUED)

FIGURE 2(c) - REAR END (CONTINUED)

Gauge 20 Straight PCB Solder Contacts (Codes OL3 and Z)



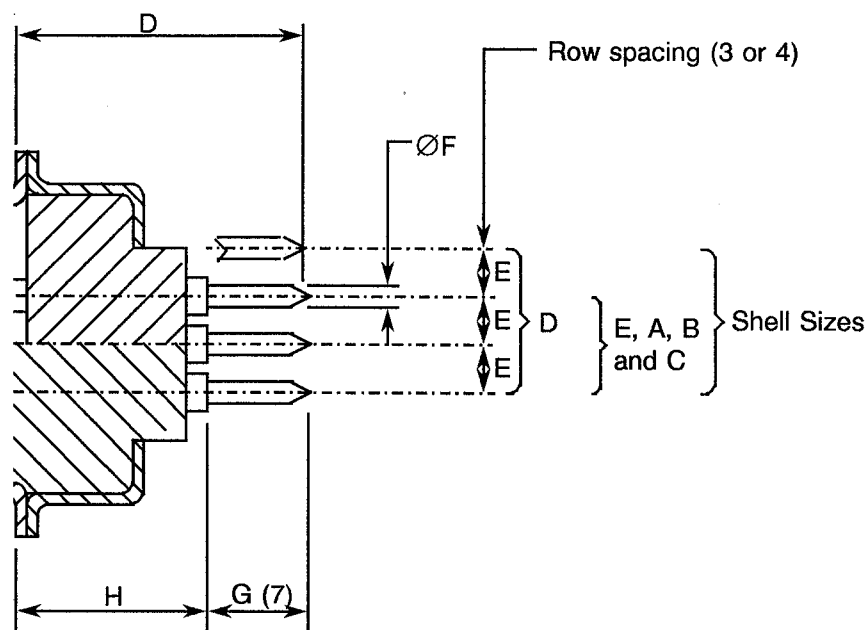
Pitch between contacts

Connector shell sizes E and A: 2.74.
Connector shell sizes B, C and D: 2.76.

Symbol/ Dim.	<u>D</u>	<u>D</u>	E	<u>ØF</u>		<u>G</u>
	(2) (3)	(4)		CODE OL3(6)	CODE Z (7)	
min.	9.7	9.9	2.77	0.50	0.69	3.1
max.	11.5	11.7	2.91	0.65	0.84	5.3

NOTES

1. All dimensions are in mm.
2. Connectors equipped with female contacts all sizes.
3. Connectors equipped with male contacts sizes E and A.
4. Connectors equipped with male contacts sizes B, C and D.
5. Typical = 2.84.
6. Typical = 0.60.
7. Typical = 0.76.
8. Dimension G is the length of the PCB tail extension of the contact.

FIGURE 2 - PHYSICAL DIMENSIONS (CONTINUED)
FIGURE 2(c) - REAR END (CONTINUED)
Gauge 22 Straight PCB Solder Contacts (Code OL3)

Pitch between contacts

Connector shell sizes E, A and B: 2.29.

Connector shell sizes C and D: 2.41.

Symbol/ Dim.	D			E		ØF	G	H		
	(2)	(3)	(4)	Sizes E, A, B, C (5)	Size D (6)			(2)	(3)	(4)
min.	-	-	-	1.91	2.01	0.50	4.6	-	-	-
max.	16.17	16.01	16.21	2.05	2.15	0.65	4.8	11.37	11.21	11.41

NOTES

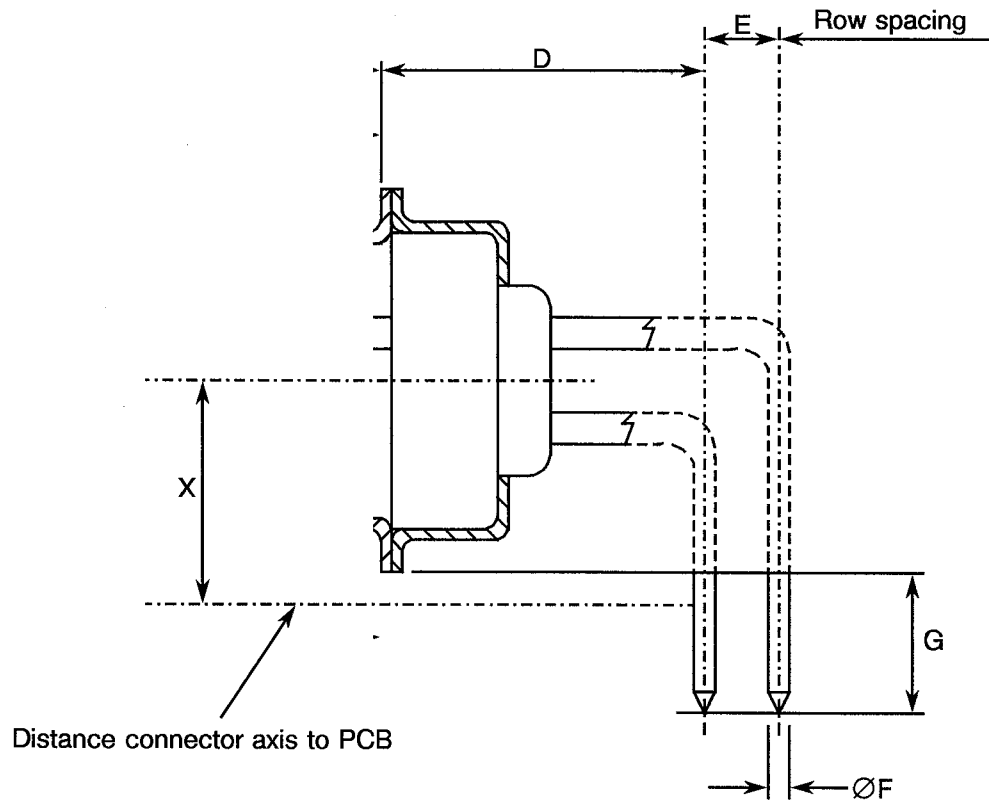
1. All dimensions are in mm.
2. Connectors equipped with female contacts all sizes.
3. Connectors equipped with male contacts sizes E and A.
4. Connectors equipped with male contacts sizes B, C and D.
5. Typical = 1.98.
6. Typical = 2.08.
7. Dimension G is the length of the PCB tail extension of the contact.



FIGURE 2 - PHYSICAL DIMENSIONS (CONTINUED)

FIGURE 2(c) - REAR END (CONTINUED)

Gauge 20 90° PCB Solder Contacts (Sizes E, A, B and C) (Codes 1AON, 1BON, 2AON and 2BON)



Pitch between contacts

Connector shell sizes E and A: 2.74.
Connector shell sizes B and C: 2.76.

Symbol/ Dim.	D		E		ØF		G	X
	(2) (3)	(4)	(*)AON (5)	(*)BON (6)	1AON 1BON (7)	2AON 2BON (8)		
min.	10.1	10.3	2.49	2.79	0.50	0.69	4.7	7.2
max.	10.3	10.5	2.59	2.89	0.65	0.84	5.3	7.5

NOTES

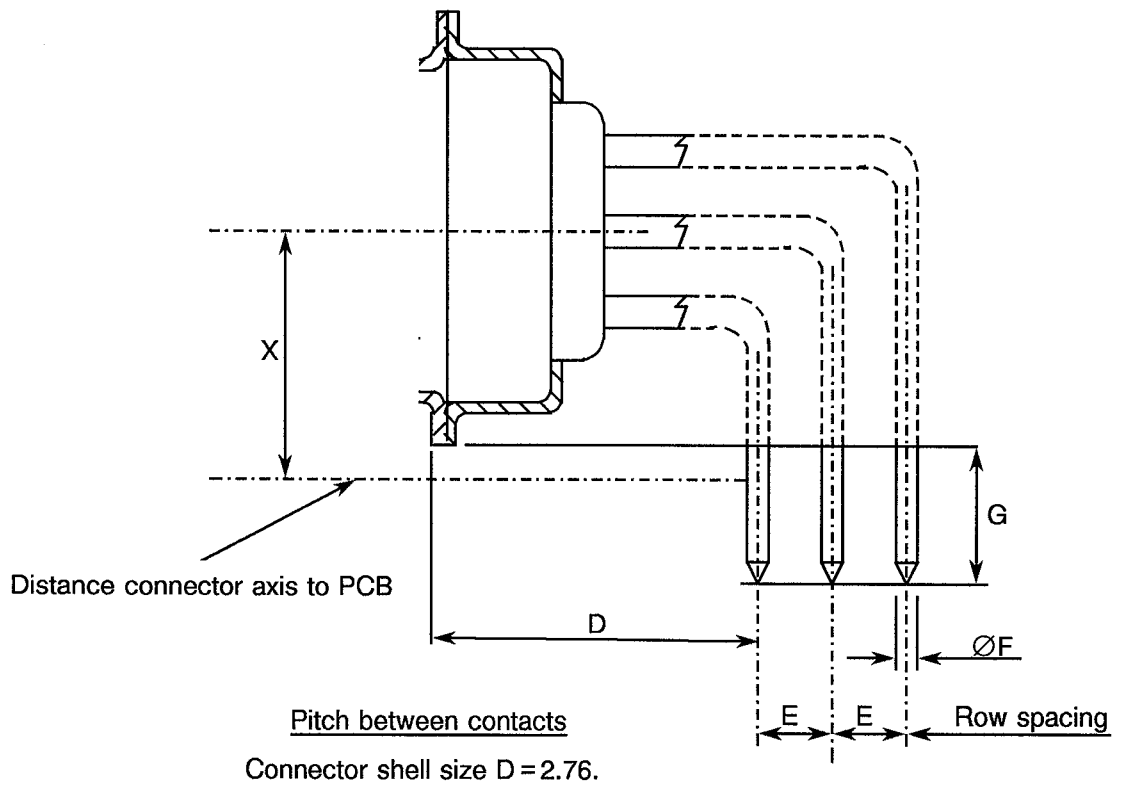
1. All dimensions are in mm.
2. Connectors equipped with female contacts all sizes.
3. Connectors equipped with male contacts sizes E and A.
4. Connectors equipped with male contacts sizes B and C.
5. Typical = 2.54.
6. Typical = 2.84.
7. Typical = 0.60.
8. Typical = 0.76.
9. Typical = 7.35.



FIGURE 2 - PHYSICAL DIMENSIONS (CONTINUED)

FIGURE 2(c) - REAR END (CONTINUED)

Gauge 20 90° PCB Solder Contacts (Size D) (Codes 1AON, 1BON, 2AON and 2BON)



Symbol/ Dim.	D		E		ØF		G	X
	(2)	(3)	(*)AON (4)	(*)BON (5)	1AON 1BON (6)	2AON 2BON (7)		
min.	10.1	10.3	2.49	2.79	0.50	0.69	4.7	8.6
max.	10.3	10.5	2.59	2.89	0.65	0.84	5.3	8.8

NOTES

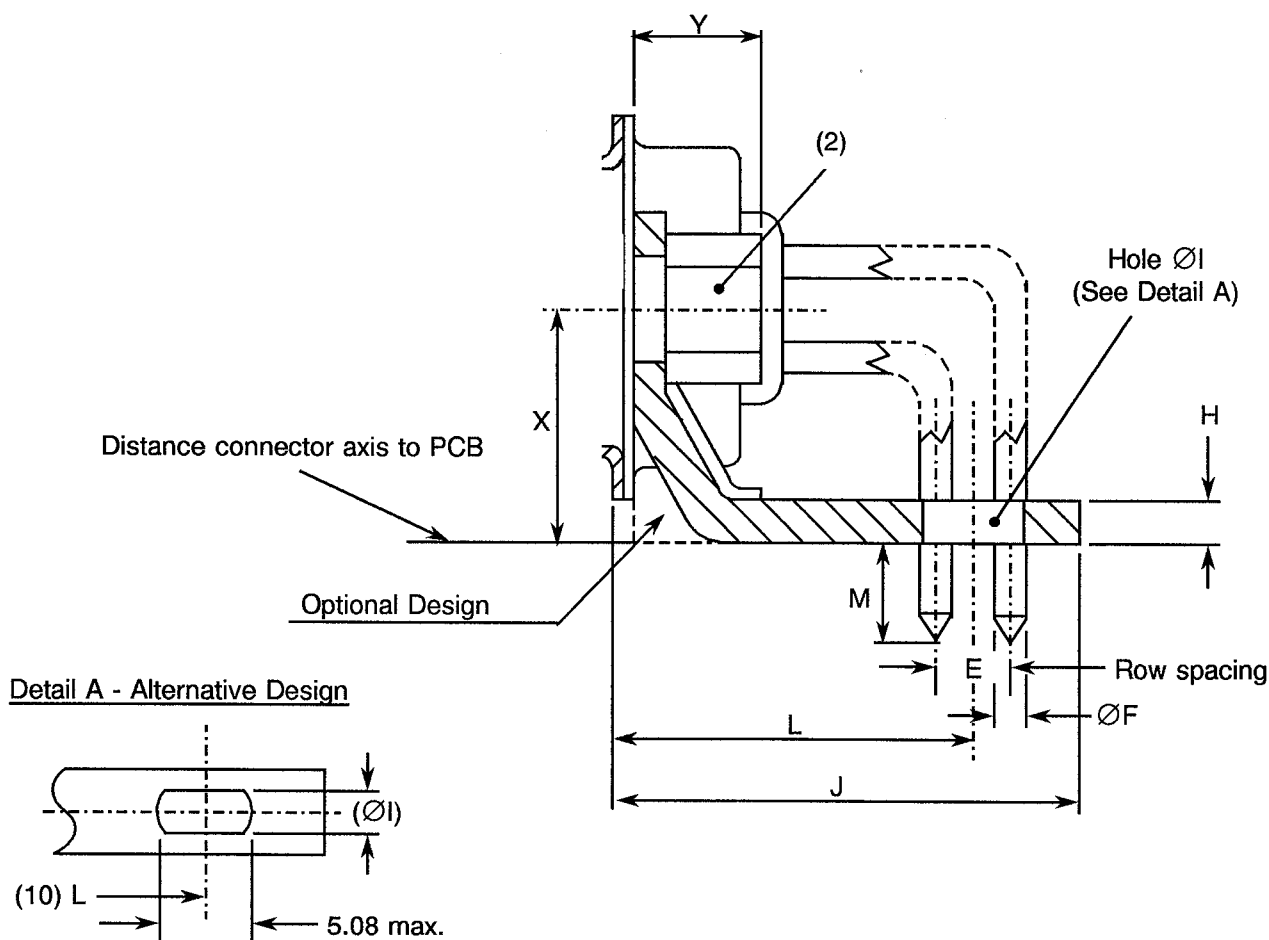
1. All dimensions are in mm.
2. Connectors equipped with female contacts.
3. Connectors equipped with male contacts.
4. Typical = 2.54.
5. Typical = 2.84.
6. Typical = 0.60.
7. Typical = 0.76.
8. Typical = 8.70.



FIGURE 2 - PHYSICAL DIMENSIONS (CONTINUED)

FIGURE 2(c) - REAR END (CONTINUED)

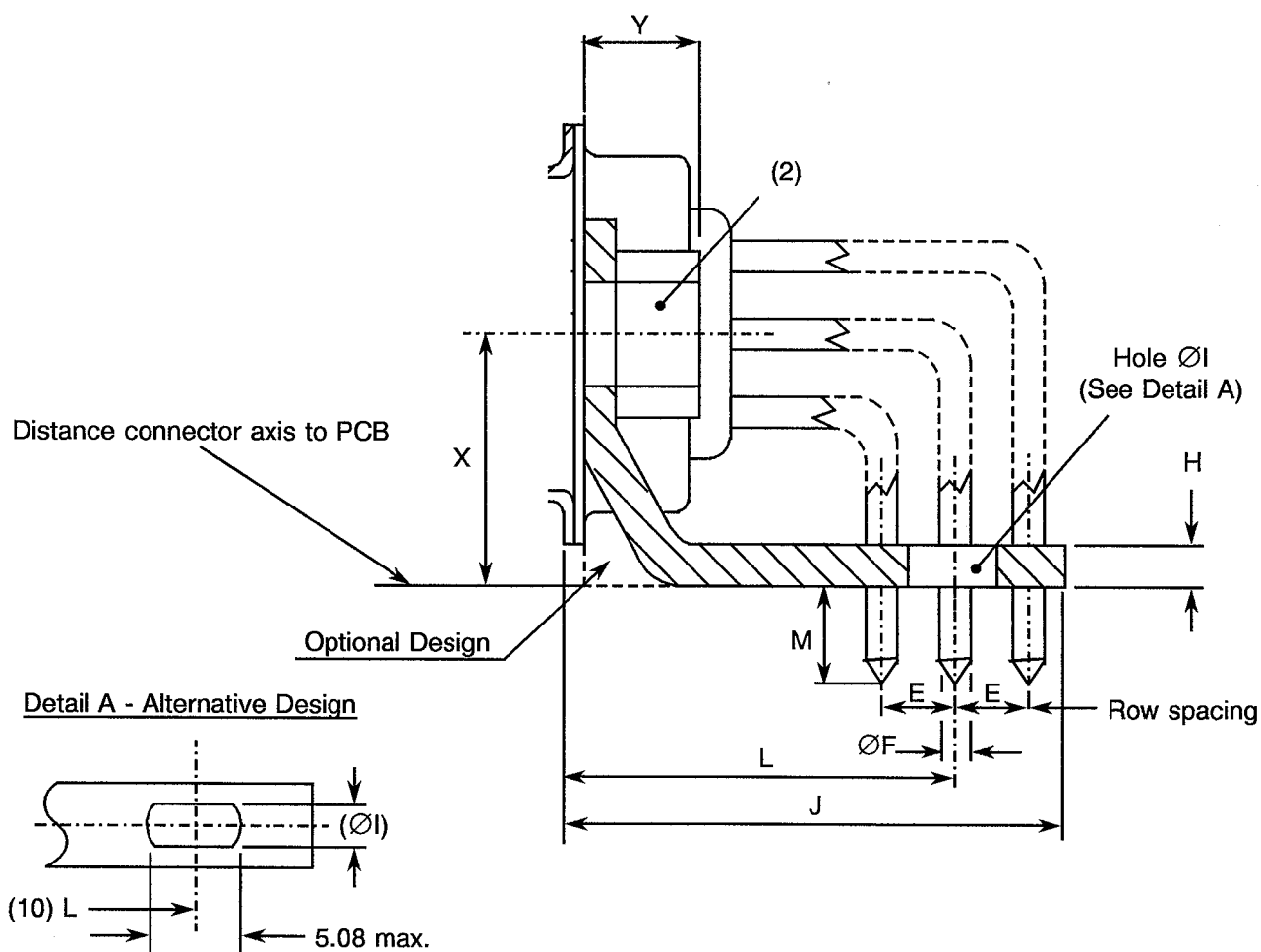
**Gauge 20 PCB Solder Contacts with 90° Brackets and Screw Locks (Sizes E, A, B and C)
(Codes 1A7N, 1A9N, 1B7N, 1B9N, 2A7N, 2A9N, 2B7N and 2B9N)**



Symbol/ Dim.	E		ØF		H	ØI	J		L				M	X	Y
	(*)A7N (3)	(*)B7N (4)	1(*)7N (5)	2(*)7N (6)			(7)	(8)	(7)		(8)				
									(*)A7N (*)A9N	(*)B7N (*)B9N	(*)A7N (*)A9N	(*)B7N (*)B9N			
min.	2.49	2.79	0.50	0.69	1.0	3.12	-	-	11.37	11.52	11.57	11.72	3.6	7.2	-
max.	2.59	2.89	0.65	0.84	3.2	3.32	15.6	15.8	11.57	11.72	11.77	11.92	4.4	7.5	7.0

NOTES

- All dimensions are in mm.
- Codes (*)A7N and (*)B7N: Nut 4-40.
Codes (*)A9N and (*)B9N: Nut M3.
- Typical = 2.54.
- Typical = 2.84.
- Typical = 0.60.
- Typical = 0.76.
- Connectors equipped with female contacts all sizes and connectors equipped with male contacts sizes E and A.
- Connectors equipped with male contacts sizes B and C.
- Typical = 7.35.
- This alternative design takes into account the different possible values of L.

FIGURE 2 - PHYSICAL DIMENSIONS (CONTINUED)
FIGURE 2(c) - REAR END (CONTINUED)
**Gauge 20 PCB Solder Contacts with 90° Brackets and Screw Locks (Size D)
 (Codes 1A7N, 1A9N, 1B7N, 1B9N, 2A7N, 2A9N, 2B7N and 2B9N)**


Symbol/ Dim.	E		ØF		H	ØI	J		L				M	X	Y
	(*)A7N (3)	(*)B7N (4)	1(*)7N (5)	2(*)7N (6)			(7)	(8)	(7)		(8)				
									(*)A7N (*)A9N	(*)B7N (*)B9N	(*)A7N (*)A9N	(*)B7N (*)B9N			
	(3)	(4)	(5)	(6)			(7)	(8)	(*)A7N (*)A9N	(*)B7N (*)B9N	(*)A7N (*)A9N	(*)B7N (*)B9N			
min.	2.49	2.79	0.50	0.69	1.0	3.12	-	-	12.64	12.94	12.84	13.14	3.6	8.6	-
max.	2.59	2.89	0.65	0.84	3.2	3.32	17.5	17.7	12.84	13.14	13.04	13.34	4.4	8.8	7.0

NOTES

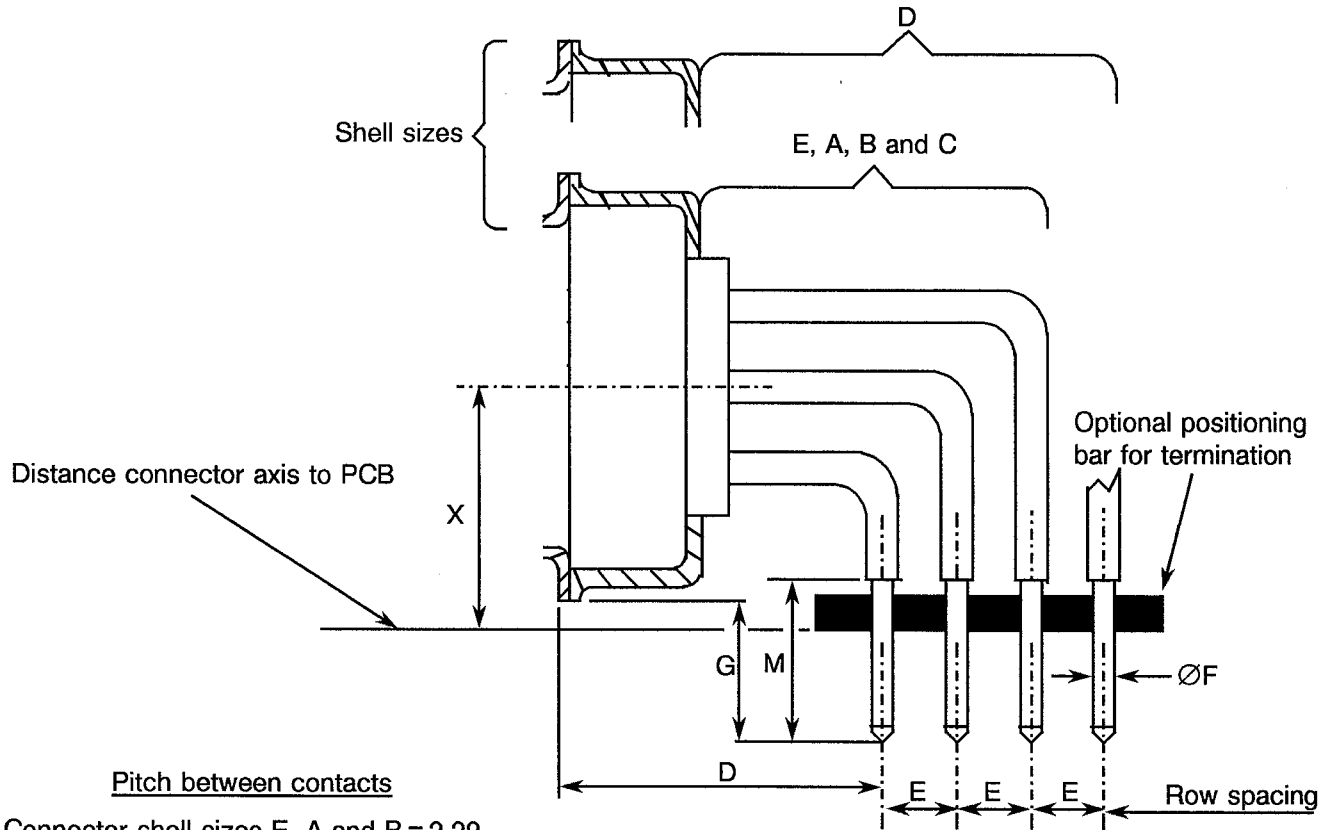
- All dimensions are in mm.
- Codes (*)A7N and (*)B7N: Nut 4-40
Codes (*)A9N and (*)B9N: Nut M3.
- Typical = 2.54.
- Typical = 2.84.
- Typical = 0.60.
- Typical = 0.76.
- Connectors equipped with female contacts.
- Connectors equipped with male contacts.
- Typical = 8.70.
- This alternative design takes into account the different possible values of L.



FIGURE 2 - PHYSICAL DIMENSIONS (CONTINUED)

FIGURE 2(c) - REAR END (CONTINUED)

**Gauge 22 90° PCB Solder Contacts
(For Sizes E, A, B, C code 1CON and Size D code 1DON)**



Connector shell sizes E, A and B = 2.29.
Connector shell sizes C and D = 2.41.

Code	Symbol/ Dim.	D		E		ØF	G	M	X
		(2)	(3)	(4)	1CON (5)				
1CON	min.	11.98	12.18	1.93	-	0.50	4.7	5.3	7.2
	max.	12.48	12.68	2.03	-	0.65	5.3	5.4	7.5
1DON	min.	11.98	12.18	-	2.03	0.50	4.7	5.3	8.6
	max.	12.48	12.68	-	2.13	0.65	5.3	5.4	8.8

NOTES

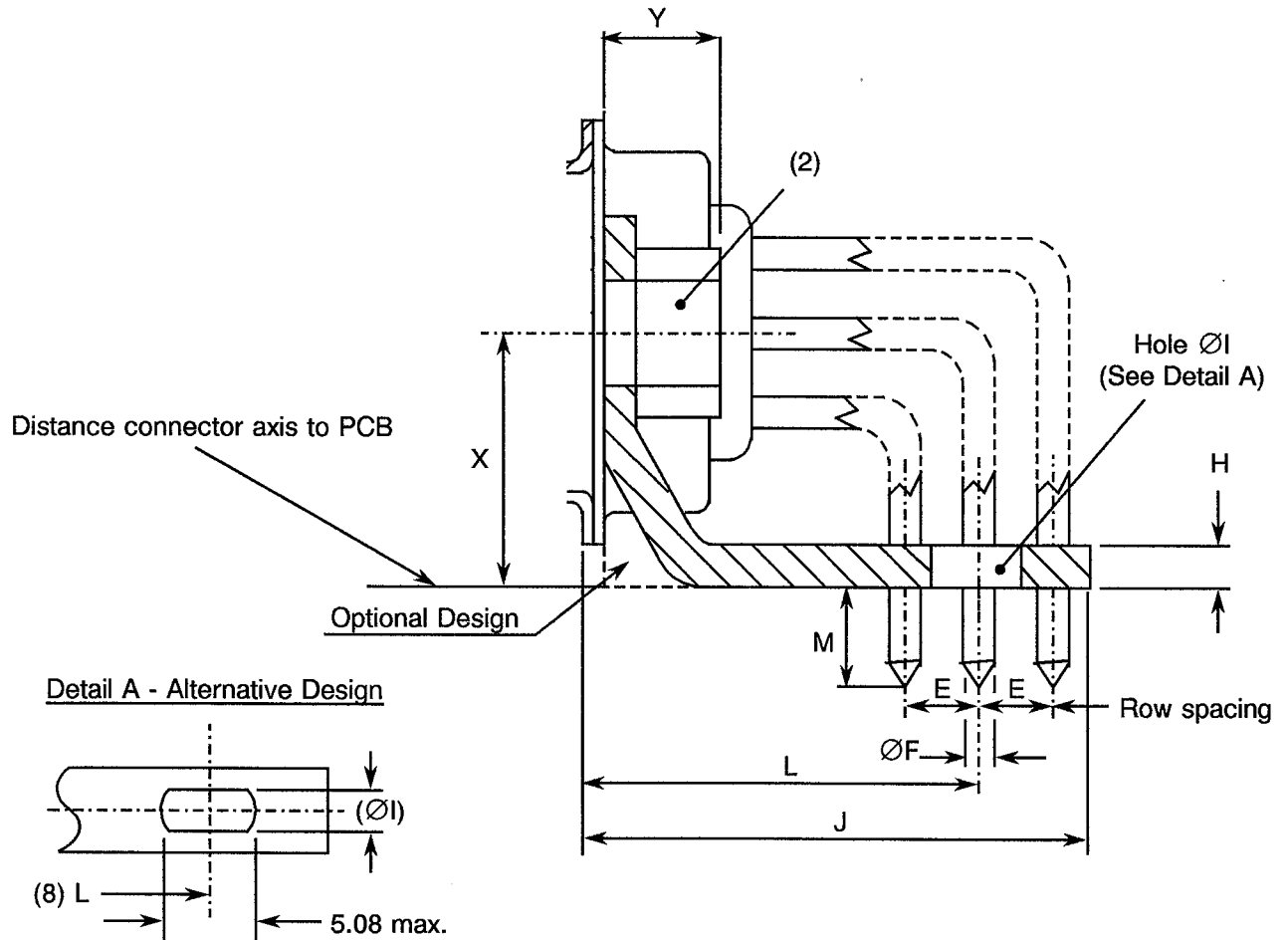
- All dimensions are in mm.
- Connectors equipped with female contacts all sizes.
- Connectors equipped with male contacts sizes E and A.
- Connectors equipped with male contacts sizes B, C and D.
- Typical = 1.98.
- Typical = 2.08.
- For sizes E, A, B and C, Typical = 7.35.
- For size D, Typical = 8.70.



FIGURE 2 - PHYSICAL DIMENSIONS (CONTINUED)

FIGURE 2(c) - REAR END (CONTINUED)

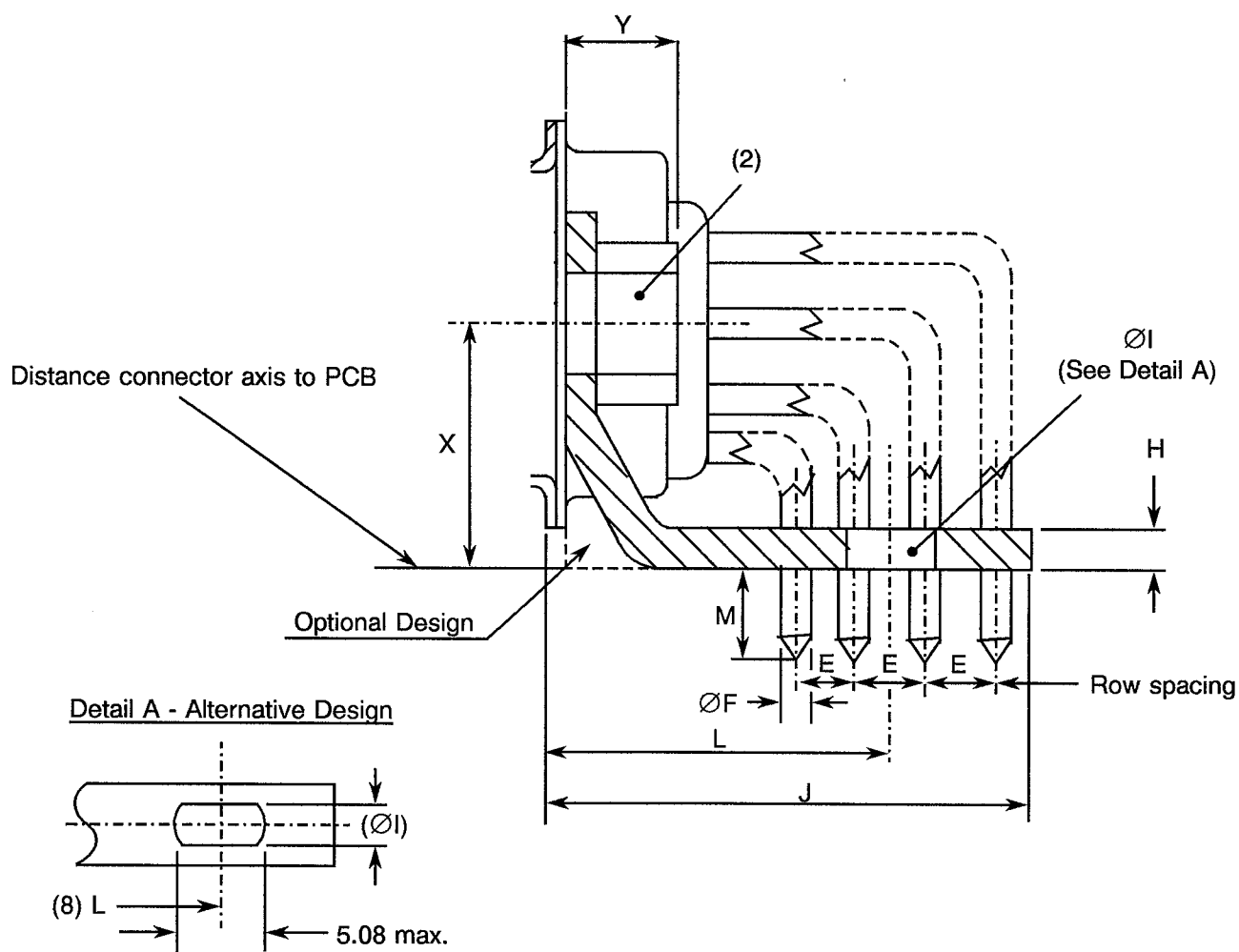
**Gauge 22 PCB Solder Contacts with 90° Brackets and Screw Locks (Sizes E, A, B and C)
(Codes 1C7N and 1C9N)**



Symbol/ Dim.	E (3)	ØF	ØI	H	J		L		M	X (7)	Y
					(4)	(6)	(5)	(6)			
min.	1.93	0.50	3.12	1.0	-	-	14.11	14.31	3.6	7.2	-
max.	2.03	0.65	3.32	3.2	18.3	18.5	14.31	14.51	4.4	7.5	7.0

NOTES

- All dimensions are in mm.
- Code 1C7N: Nut 4-40.
Code 1C9N: Nut M3.
- Typical = 1.98.
- Connectors equipped with female contacts all sizes and connectors equipped with male contacts sizes E and A.
- Connectors equipped with male contacts sizes B and C.
- Optional positioning bar for termination included.
- Typical = 7.35.
- This alternative design takes into account the different possible values of L.

FIGURE 2 - PHYSICAL DIMENSIONS (CONTINUED)
FIGURE 2(c) - REAR END (CONTINUED)
**Gauge 22 PCB Solder Contacts with 90° Brackets and Screw Locks (Size D)
 (Codes 1D7N and 1D9N)**


Symbol/ Dim.	E (3)	ØF	ØI	H	J		L		M	X (7)	Y
					(4) (6)	(5) (6)	(4)	(5)			
min.	2.03	0.50	3.12	1.0	-	-	15.25	15.45	3.6	8.6	-
max.	2.13	0.65	3.32	3.2	20.5	20.7	15.45	15.65	4.4	8.8	7.0

NOTES

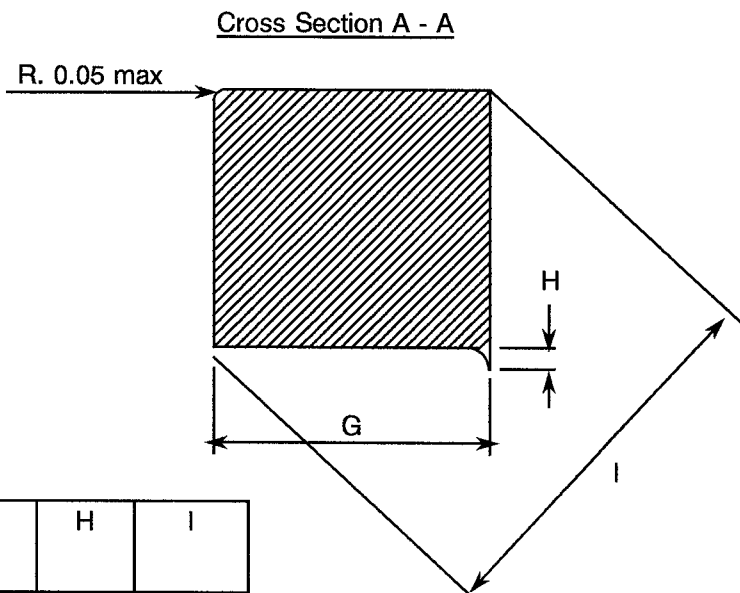
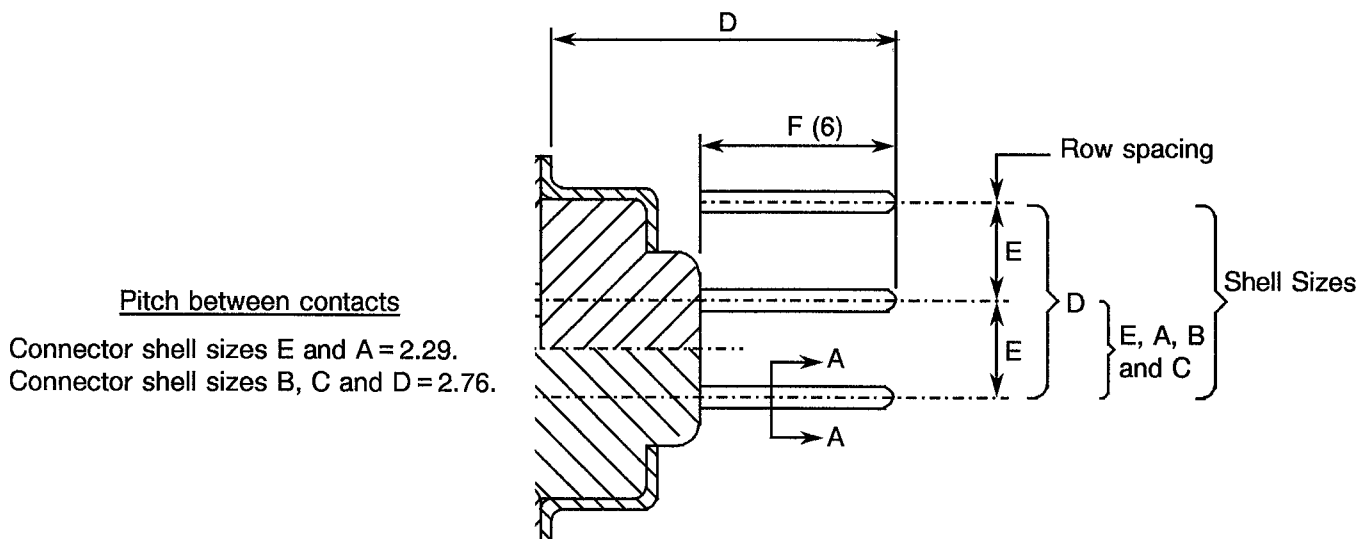
- All dimensions are in mm.
- Code 1D7N: Nut 4-40.
Code 1D9N: Nut M3.
- Typical = 2.08.
- Connectors equipped with female contacts.
- Connectors equipped with male contacts.
- Optional positioning bar for termination included.
- Typical = 8.70.
- This alternative design takes into account the different possible values of L.



FIGURE 2 - PHYSICAL DIMENSIONS (CONTINUED)

FIGURE 2(c) - REAR END (CONTINUED)

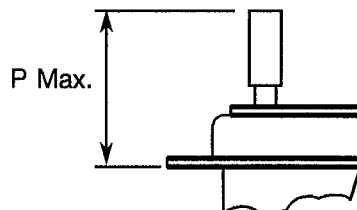
Gauge 20 Wire-Wrap Contacts (Code F179A)



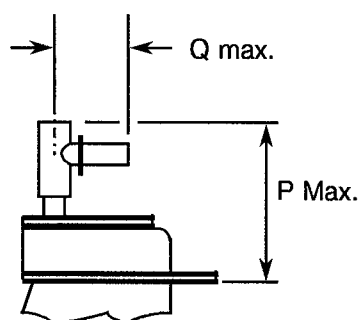
Symbol/ Dim.	D		E (5)	F (6)	G	H	I
	(2)	(3)					
min.	-	-	2.77	12.6	0.59	-	0.787
max.	20.1	20.3	2.91	12.8	0.61	0.02	0.864

NOTES

1. All dimensions are in mm.
2. Connectors equipped with female contacts all sizes.
3. Connectors equipped with male contacts sizes E and A.
4. Connectors equipped with male contacts sizes B, C and D.
5. Typical = 2.84.
6. Dimension F is the length of the square part of the contact.

FIGURE 2 - PHYSICAL DIMENSIONS (CONTINUED)
FIGURE 2(c) - REAR END (CONTINUED)
Power and Coaxial Contacts (Code -)
Straight Coaxial Contacts


Symbol	Connectors equipped with Variant Number per 3401/004			
	3401/004 Variants 01-02-05-06-11-12-15-16		3401/004 Variants 09-10-19-20	
P	19.6 (2) (3)	19.8 (4)	22.3 (2) (3)	22.5 (4)

90° Coaxial Contacts


Symbol	Connectors equipped with 3401/004 Variants 03-04-07-08-13-14-17-18	
P	14.3 (2) (3)	14.5 (4)
Q	12.5	

NOTES

1. All dimensions are in mm.
2. Connectors equipped with female contacts all sizes.
3. Connectors equipped with male contacts sizes E and A.
4. Connectors equipped with male contacts sizes B, C and D.



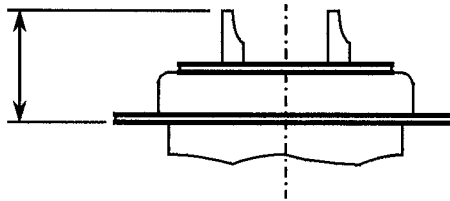
FIGURE 2 - PHYSICAL DIMENSIONS (CONTINUED)

FIGURE 2(c) - REAR END (CONTINUED)

Power and Coaxial Contacts (Code -) (Continued)

Power Solder Contact

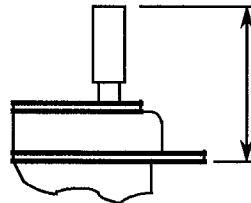
17.7 Max. (2) (3)
17.9 Max (4)



3401/001 connectors equipped with contact Variants 01 through 06 of 3401/040

Power Crimp Contact


19.8 Max. (2) (3)
20 Max (4)



3401/001 connectors equipped with contact Variants 07 through 12 of 3401/040

NOTES

1. All dimensions are in mm.
2. Connectors equipped with female contacts all sizes.
3. Connectors equipped with male contacts sizes E and A.
4. Connectors equipped with male contacts sizes B, C and D.

	<p style="text-align: center;">ESA/SCC Detail Specification No. 3401/001</p>		<p>PAGE 30 ISSUE 7</p>
---	--	--	----------------------------

4. REQUIREMENTS

4.1 GENERAL

The complete requirements for procurement of the connectors specified herein are stated in this specification and ESA/SCC Generic Specification No. 3401. Deviations from the Generic Specification, applicable to this specification only, are listed in Para. 4.2.

Deviations from the applicable Generic Specification and this Detail Specification, formally agreed with specific Manufacturers on the basis that the alternative requirements are equivalent to the ESA/SCC requirements and do not affect the components' reliability, are listed in the appendices attached to this specification.

4.2 DEVIATIONS FROM GENERIC SPECIFICATION

4.2.1 Deviations from Special In-process Controls

None.

4.2.2 Deviations from Final Production Tests (Chart II)

(a) Para. 9.1.1.4, Mated Shell Conductivity: Not applicable.

(b) Para. 9.9, Seal Test: Not applicable.

4.2.3 Deviations from Burn-in and Electrical Measurements (Chart III)

Not applicable.

4.2.4 Deviations from Qualification Tests (Chart IV)

(a) Para. 9.1.1.4, Mated Shell Conductivity: Not applicable.

(b) Para. 9.9, Seal Test: Not applicable.

(c) Para. 9.24, Jackscrew Retention: Not applicable.

(d) Para. 9.27, Maintenance Ageing: Not applicable to gauge 20 and 22 contacts.

4.2.5 Deviations from Lot Acceptance Tests (Chart V)

(a) Para. 9.1.1.4, Mated Shell Conductivity: Not applicable.

(b) Para. 9.9, Seal Test: Not applicable.

4.3 MECHANICAL REQUIREMENTS

4.3.1 Dimension Check

The dimensions of the connectors specified herein shall be verified in accordance with the requirements set out in Para. 9.6 of ESA/SCC Generic Specification 3401 and shall conform to those shown in Figure 2 of this specification. Only the underlined dimensions shall be checked during procurement.

4.3.2 Weight

The maximum weight of the connectors specified herein, with contacts, shall be as specified in Table 1(a).

4.3.3 Contact Capability

For the purpose of this test, the pick-up and drop weights shall be as follows.

CONTACTS	MEASUREMENTS	PICK-UP WEIGHT	DROP WEIGHT
Gauge 20	Weight (g)	28.35	226.8
	Pin diameter (mm)	0.990 to 0.993	1.039 to 1.040
	Insertion depth (mm)	4.0	4.0
Gauge 22	Weight (g)	19.84	226.8
	Pin diameter (mm)	0.749 to 0.751	0.773 to 0.775
	Insertion depth (mm)	4.0	4.0

See ESA/SCC Detail Specifications 3401/004 and 3401/040 for coaxial and power contacts.

4.3.4 Contact Retention (in insert)

The contact retention force of gauge 20 and 22 contacts within the insert shall be 40N.

See ESA/SCC Detail Specifications 3401/004 and 3401/040 for coaxial and power contacts.

4.3.5 Mating and Unmating Forces

The forces applied for mating and unmating of the connectors shall conform to the values specified in Table 1(a).

4.3.6 Insert Retention (in shell)

Connector inserts shall withstand a pressure of 42.8N/cm² without being dislodged from the shell.

4.3.7 Jackscrew Retention

Not applicable.

4.3.8 Contact Insertion and Withdrawal Forces

See ESA/SCC Detail Specifications 3401/004 & 3401/040 for coaxial and power contacts. Not applicable to other contact types.

4.3.9 Engagement and Separation Forces

The engagement and separation forces of the female contacts shall be tested with the applicable test pin and shall not exceed the values of the table hereunder.

CONTACTS	MEASUREMENTS	DIAMETER (mm)		ENGAGEMENT MAX (N)	SEPARATION (N)	
		MIN	MAX		MIN	MAX
Gauge 20	Max Ø Test Pin	1.039	1.040	3.33	-	2.22
	Min Ø Test Pin	0.990	0.993	-	0.28	-
Gauge 22	Max Ø Test Pin	0.773	0.775	3.33	-	2.22
	Min Ø Test Pin	0.749	0.751	-	0.20	-

See ESA/SCC Detail Specifications 3401/004 and 3401/040 for coaxial and power contacts.



4.3.10 Oversize Pin Exclusion

The diameter of the test pin and the force applied to it shall be as follows.

CONTACTS	TEST PIN DIA. (mm)		FORCE (N) MAX
	MIN	MAX	
Gauge 20	1.166	1.170	3.33
Gauge 22	0.905	0.907	2.43

See ESA/SCC Detail Specifications 3401/004 and 3401/040 for coaxial and power contacts.

4.3.11 Probe Damage

The probe diameter and the moment at the end of the probe shall be as follows.

CONTACTS	PROBE DIA. (mm)		MOMENT (N.cm)
	MIN	MAX	
Gauge 20	1.007	1.033	5.65
Gauge 22	0.749	0.774	1.30

See ESA/SCC Detail Specifications 3401/004 and 3401/040 for coaxial and power contacts.

4.3.12 Solderability

Size A soldering iron shall be used.

See ESA/SCC Detail Specifications 3401/004 and 3401/040 for coaxial and power contacts.

4.4 MATERIALS AND FINISHES

The materials and finishes shall be as specified herein. Where a definite material is not specified, a material which will enable the connectors specified herein to meet the performance requirements of this specification shall be used. Acceptance or approval of any constituent material does not guarantee acceptance of the finished product.

4.4.1 Shells

Shells shall be made of brass. The plating thickness shall be 0.7µm minimum gold over 1.0µm minimum of copper.

4.4.2 Inserts

Inserts shall be made of glass-fibre filled diallyphthalate resin or a suitable thermoplastic material.

4.4.3 Contacts

The contact body shall be made of copper alloy with an underplate of 1.0µm minimum of copper to MIL-C-14450, gold plated with 1.27µm minimum of gold, Type 2 Grade C of MIL-G-45204.

The female contact spring element shall be made of copper alloy with an underplate of 1.0µm minimum of nickel or copper to MIL-C-14450, gold plated with 1.27µm minimum of gold, Type 2 Grade C of MIL-G-45204.

4.4.4 Contact Retaining Clip

Not applicable to gauge 20 and 22 contacts.

See ESA/SCC Detail Specifications 3401/004 and 3401/040 for coaxial and power contacts.

4.4.5 Guiding and Locking Devices

As specified in ESA/SCC Detail Specification No. 3401/022.

4.4.6 Magnetism Level

The allowable value of magnetism shall not exceed that specified for the relevant level (see Para. 4.5.4.7). Only magnetism levels NMC and NMD are verified.

4.5 MARKING

4.5.1 General

The marking of all components delivered to this specification shall be in accordance with the requirements of ESA/SCC Basic Specification No. 21700 and the following paragraphs. When the component is too small to accommodate all of the marking specified, as much as space permits shall be marked and the marking information, in full, shall accompany the component in its primary package.

The information to be marked and the order of precedence, shall be as follows:-

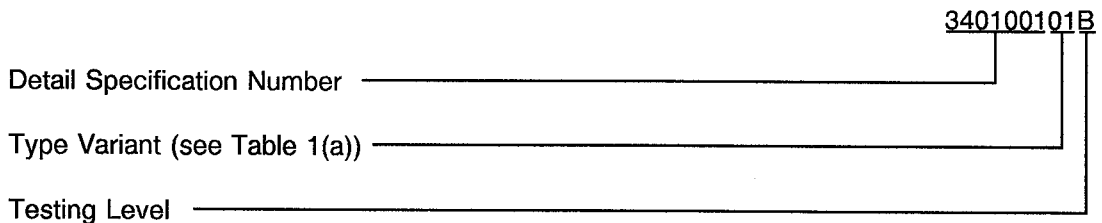
- (a) Contact Identification.
- (b) The SCC Component Number.
- (c) Characteristics
- (d) Traceability Information.

4.5.2 Contact Position

Contact position shall be marked on the inserts in accordance with Figure 2(b).

4.5.3 The SCC Component Number

The SCC Component Number shall be constituted and marked as follows:

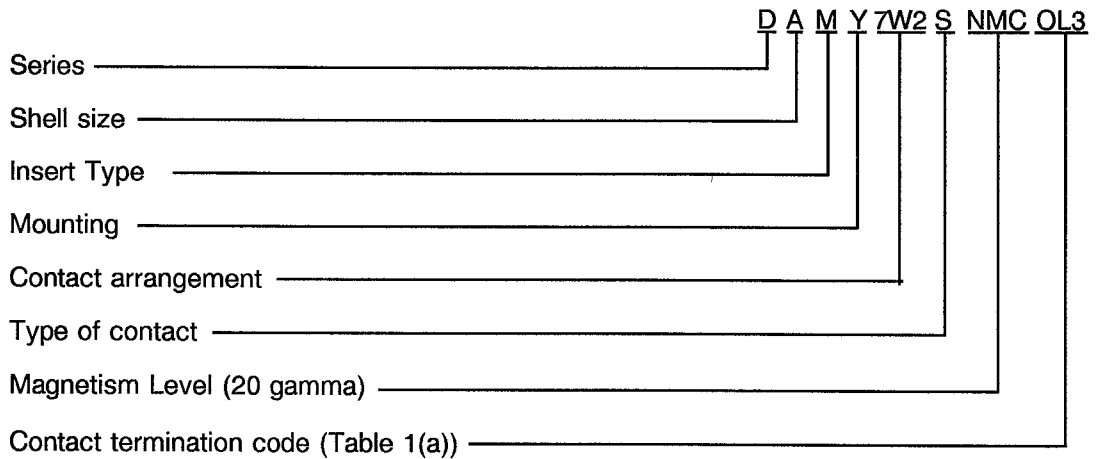


4.5.4 Characteristics

The characteristics to be marked in the following order of precedence are:-

- (a) Series.
- (b) Shell size.
- (c) Insert type.
- (d) Mounting.
- (e) Contact arrangement.
- (f) Type of contact.
- (g) Magnetism Level.
- (h) Contact termination code.

The information shall be constituted and marked as follows:-



4.5.4.1 Series

This connector series shall be designated by the letter 'D'.

4.5.4.2 Shell Size

The shell size shall be indicated by the letters specified hereafter.

Code	E	A	B	C	D
------	---	---	---	---	---

4.5.4.3 Insert Type

This insert type is defined by the letter 'M'.

4.5.4.4 Mounting

The letter "E" indicates a captive nut.

The letter "Y" indicates a floating mount.

If the shell has fixed mounting holes, these letters shall be omitted.

**4.5.4.5 Contact Arrangement**

The number of contacts shall be as shown in Figure 2(b) and contact arrangements shall be indicated by the codes specified hereafter.

CODE	SHELL SIZE	NUMBER OF CONTACTS GAUGE 20	NUMBER OF CONTACTS GAUGE 22	NUMBER OF COAXIAL AND/OR POWER CONTACTS
9	E	9	0	0
5W1	E	4	0	1
15	A	15	0	0
15	E	0	15	0
3W3	A	0	0	3
3WK3	A	0	0	3 (1)
7W2	A	5	0	2
11W1	A	10	0	1
25	B	25	0	0
26	A	0	26	0
5W5	B	0	0	5
9W4	B	5	0	4
13W3	B	10	0	3
17W2	B	15	0	2
21W1	B	20	0	1
37	C	37	0	0
8W8	C	0	0	8
13W6	C	7	0	6
17W5	C	12	0	5
21WA4	C	17	0	4 (2)
21W4	C	17	0	4 (2)
25W3	C	22	0	3
27W2	C	25	0	2
44	B	0	44	0
50	D	50	0	0
24W7	D	17	0	7
36W4	D	32	0	4
43W2	D	41	0	2
47W1	D	46	0	1
62	C	0	62	0
78	D	0	78	0

NOTES

1. 2 male plus 1 female or 2 female plus 1 male (see Para. 4.5.4.6).
2. See Figure 2 for physical differences.

4.5.4.6 Type of Contact

The contact types shall be indicated by the following code letters.

CODE LETTER	CONTACT TYPE
P	Male
S	Female

For the 3WK3 arrangement, the contact cavities A1 and A3 shall determine the code letter to be used.

4.5.4.7 Magnetism Level

The following codes shall be used for magnetism level.

CODE	DEFINITION
NMB	Magnetism Level: \leq 200 gamma (1)
NMC	Magnetism Level: \leq 20 gamma
NMD	Magnetism Level: \leq 2 gamma

NOTES

1. Guaranteed, but not measured.

4.5.4.8 Contact Termination Code

Contact terminations shall be indicated as given in Table 1(a), Contact Types. For mixed contact arrangements, (see Figure 2(b)), the gauge 20 contact type shall determine the contact code used.

4.5.5 Traceability Information

Traceability information shall be marked in accordance with the requirements of ESA/SCC Basic Specification No. 21700.

4.6 ELECTRICAL MEASUREMENTS

4.6.1 Electrical Measurements at Room Temperature

The parameters to be measured in respect of electrical characteristics are scheduled in Table 2. Unless otherwise specified, these measurements shall be performed at $T_{amb} = +22 \pm 3$ °C.

4.6.2 Electrical Measurements at High and Low Temperatures

Not applicable.

4.6.3 Circuit for Electrical Measurements (Figure 4)

Not applicable.

4.7 BURN-IN AND ELECTRICAL MEASUREMENTS

Not applicable.

TABLE 2 - ELECTRICAL MEASUREMENTS AT ROOM TEMPERATURE



No.	CHARACTERISTIC	SYMBOL	ESA/SCC 3401 TEST METHOD	TEST CONDITION	LIMITS		UNIT
					MIN.	MAX.	
1	Insulation Resistance	R _i	Para. 9.1.1.1	Para. 9.1.1.1	5000	-	MΩ
2	Voltage Proof Leakage Current	I _L	Para. 9.1.1.2	(1)	-	2.0	mA
3	Mated Shell Conductivity (Voltage Drop) (2)	V _d	Para. 9.1.1.4	Para. 9.1.1.4	Not applicable		mV
4	Contact Resistance (Low Level Current) Gauge 20 Gauge 22 (PCB Contacts) Coaxial } Power } (3)	R _{cl} max.	Para. 9.1.1.3	Para. 9.1.1.3	-	6.0 12	mΩ
5	Contact Resistance (Rated Current) (3)	R _{cr} max.	Para. 9.1.1.3	Gauge 20: 7.5A Gauge 22: 3.0A	-	5.0 10	mΩ

NOTES

1. - Gauge 20 contacts: 1250Vrms.
 - Gauge 22 contacts, power and straight coaxial contacts: 1000Vrms.
 - 90° Coaxial contacts: 800Vrms.
 - For mixed contact arrangements, the voltage applied between dissimilar contacts shall be the higher that would be applied between either of the contacts in question tested with an identical contact.
2. Applicable to mated connectors with grounding option.
3. See ESA/SCC Detail Specifications 3401/004 and 3401/040 for coaxial and power contacts.

TABLES 3, 4 AND 5

Not applicable

 	ESA/SCC Detail Specification No. 3401/001	PAGE 38 ISSUE 7
--	--	--------------------

4.8 ENVIRONMENTAL AND ENDURANCE TESTS (CHARTS IV AND V OF ESA/SCC GENERIC SPECIFICATION NO. 3401)

4.8.1 Measurements and Inspections on Completion of Environmental Tests

The parameters to be measured and inspections to be performed on completion of environmental testing shall be those specified in Table 6. Unless otherwise specified, the measurements shall be performed at $T_{amb} = +22 \pm 3$ °C.

4.8.2 Measurements and Inspections at Intermediate Points during Endurance Tests

Not applicable.

4.8.3 Measurements and Inspections on Completion of Endurance Tests

The parameters to be measured and inspections to be performed on completion of endurance tests shall be those specified in Table 6. Unless otherwise specified, the measurements shall be performed at $T_{amb} = +22 \pm 3$ °C.

4.8.4 Conditions for Operating Life Test (Part of Endurance Testing)

Not applicable.

4.8.5 Electrical Circuits for Operating Life Test (Figure 5)

Not applicable.

4.8.6 Conditions for High Temperature Storage Test (Part of Endurance Testing)

The requirements for the high temperature storage test are specified in Section 9 of ESA/SCC Generic Specification No. 3401. The conditions for high temperature storage testing shall be the maximum storage temperature specified in Table 1(b) of this specification.

TABLE 6 - MEASUREMENTS AND INSPECTIONS ON COMPLETION OF ENVIRONMENTAL AND ENDURANCE TESTING

NO.	ESA/SCC GENERIC NO. 3401		MEASUREMENTS AND INSPECTIONS		SYMBOL	LIMITS		UNIT
	ENVIRONMENTAL AND ENDURANCE TESTS (1)	TEST METHOD AND CONDITIONS	IDENTIFICATION	CONDITIONS		MIN	MAX	
01	Seal Test	Para. 9.9	ESA/SCC 3401 Para. 9.9			Not applicable		
02	Wiring	Para. 9.10 & Table 1(a) of this spec.	Low Level Contact Resist.	Table 2 Item 4	Rcl	Table 2 Item 4		
03	Vibration	Para. 9.11	Initial Measurements Coupling Screw(s) Unlocking Torque Final Measurements Full Engagement Coupling Screw(s) Unlocking Torque Drift Visual Examination	-	-	Record Values		
			Visual Examination	-	Δ	-25	+25	%
04	Shock or Bump	Para. 9.12	Full Engagement Visual Examination	-		-	-	
05	Climatic Sequence	Para. 9.13	Dry Heat Insulation Resistance Low Air Pressure Voltage Proof Leakage Curr. Damp Heat Insulation Resistance Final Measurements External Visual Inspection Insulation Resistance Voltage Proof Leakage Curr.	At High Temperature Table 2 Item 1 Figure 1 Immediately after test Table 2 Item 1 After 1-24 hrs Recovery ESA/SCC 3401 Para. 9.7 Table 2 Item 1 Table 2 Item 2	Ri I _L Ri Ri I _L	1 000	-	MΩ
						ESA/SCC 3401 Para. 9.13.5		
						100	-	MΩ
						ESA/SCC 3401 Para. 9.7		
						Table 2 Item 1 Table 2 Item 2		
06	Plating Thickness	Para. 9.14	Thickness	-	-	Para. 4.4.3 of this spec		
07	Joint Strength (N/A to solder contacts)	Para. 9.15	ESA/SCC 3401 Para. 9.15	-	-	ESA/SCC 3401 Para. 9.15		
08	Rapid Change of Temperature	Para. 9.16	Visual Examination Insulation Resistance Voltage Proof Leakage Curr.	-	-	-	-	
				Table 2 Item 1	Ri	Table 2 Item 1		
				Table 2 Item 2	I _L	Table 2 Item 2		
09	Contact Retention (in insert)	Para. 9.17 & Para. 4.3.4 of this spec.	Contact Displacement	-	-	ESA/SCC 3401 Para. 9.17		
10	Endurance	Para. 9.18	Initial Measurements Mating/Unmating Forces Low Level Contact Resist Mated Shell Conductivity Final Measurements Visual Examination Mating/Unmating Forces Low Level Contact Resistance Drift Mated Shell Conductivity Insulation Resistance Voltage Proof Leakage Curr.	Table 2 Item 4 Table 2 Item 3 Table 2 Item 4 Table 2 Item 5 Table 2 Item 3 Table 2 Item 1 Table 2 Item 2	F Rcl Vd - F ΔRcl Vd Ri I _L	Para. 4.3.5 of this spec	Record Values	Not applicable
						-	-	-
						Para. 4.3.5 of this spec		
						-	3.0	mΩ
						Not applicable		
						Table 2 Item 1 Table 2 Item 2		

NOTES 1. The tests in this table refer to either Chart IV or V and shall be used as applicable.



TABLE 6 - MEASUREMENTS AND INSPECTIONS ON COMPLETION OF ENVIRONMENTAL AND ENDURANCE TESTING (CONTINUED)

NO.	ESA/SCC GENERIC NO. 3401		MEASUREMENTS AND INSPECTIONS		SYMBOL	LIMITS		UNIT
	ENVIRONMENTAL AND ENDURANCE TESTS (1)	TEST METHOD AND CONDITIONS	IDENTIFICATION	CONDITIONS		MIN	MAX	
11	Permanence of Marking	Para. 9.19	-	-	-	-	-	
12	Mating/Unmating Forces	Para. 9.20	Force	-	F	Para. 4.3.5 of this spec		
13	High Temperature Storage	Para. 9.21	Initial Measurements Low Level Contact Resis. Mated Shell Conductivity	Table 2 Item 4 Table 2 Item 3	Rcl Vd	Record Values Not applicable		
			Final Measurements Visual Examination Mating/Unmating Forces Low Level Contact Resistance Drift Rated Current Contact Resis. Mated Shell Conductivity Insulation Resistance Voltage Proof Leakage Curr. Contact Retention (in insert)	- Table 2 Item 4 Table 2 Item 5 Table 2 Item 3 Table 2 Item 1 Table 2 Item 2 Para 4.3.4 of this spec.	- F ΔRcl Rcr Vd Ri I _L	- Para. 4.3.5 of this spec - 3.0 Table 2 Item 5 Not applicable Table 2 Item 1 Table 2 Item 2 ESA/SCC 3401 Para. 9.17	m Ω	
14	Corrosion	Para. 9.22	Visual Examination	-	-	-	-	
15	Insert Retention (in shell)	Para. 9.23 & Para. 4.3.6 of this spec.	Visual Examination	-	-	Para. 4.3.6		
16	Jackscrew Retention	Para. 9.24 & Para. 4.3.7 of this spec.	Visual Examination	-	-	Not applicable		
17	High Temperature Measurements	Para. 9.25	Insulation Resistance	Table 2 Item 1	Ri	500	-	M Ω
18	Overload Test	Para. 9.26	Internal Temperature		T	-	+ 100	$^{\circ}C$
			Rated Current Contact Resis. Mated Shell Conductivity Insulation Resistance Voltage Proof Leakage Curr.	Table 2 Item 5 Table 2 Item 3 Table 2 Item 1 Table 2 Item 2	Rcr Vd Ri I _L	Table 2 Item 5 Not applicable Table 2 Item 1 Table 2 Item 2		
19	Maintenance Ageing	Para. 9.27 & Para. 4.2.4 of this spec.	Visual Examination Contact Retention (in insert)	- Para 4.3.4 of this spec.	-	-	-	ESA/SCC 3401 Para. 9.17
			Contact Insertion & Withdrawal Forces	Para. 4.3.8 of this spec.			Para. 4.3.8	

NOTES 1. The tests in this table refer to either Chart IV or V and shall be used as applicable.

**SCC**ESA/SCC Detail Specification
No. 3401/001

PAGE 41

ISSUE 7

TABLE 6 - MEASUREMENTS AND INSPECTIONS ON COMPLETION OF ENVIRONMENTAL AND ENDURANCE TESTING (CONTINUED)

NO.	ESA/SCC GENERIC NO. 3401		MEASUREMENTS AND INSPECTIONS		SYMBOL	LIMITS		UNIT
	ENVIRONMENTAL AND ENDURANCE TESTS (1)	TEST METHOD AND CONDITIONS	IDENTIFICATION	CONDITIONS		MIN	MAX	
20	Engage/Separation Forces	Para. 9.28 & Para. 4.3.9 of this spec	Force	-	F	Para. 4.3.9		
21	Oversize Pin Exclusion	Para. 9.29 & Para. 4.3.10 of this spec				ESA/SCC 3401 Para. 9.29		
22	Probe Damage	Para. 9.30 & Para. 4.3.11 of this spec	Contact Separation Force	Para. 4.3.9 of this spec	F	Para. 4.3.9		
23	Solderability	Para. 9.31 & Para. 4.3.12 of this spec.			-	ESA/SCC 3401 Para. 9.31		

NOTES

1. The tests in this table refer to either Chart IV or V and shall be used as applicable.