



europaean space agency
agence spatiale européenne

Pages 1/20

CONTACTS, COAXIAL, CRIMP-TYPE AND SOLDER-TYPE,

FOR 3401/001 AND 3401/002 CONNECTORS

ESA/SCC Detail Specification No. 3401/004



space components
coordination group

Issue/Rev.	Date	Approved by	
		SCCG Chairman	ESA Director General or his Deputy
Issue 1	September '86	<i>[Signature]</i>	<i>[Signature]</i>
Revision 'A'	December 1986	<i>[Signature]</i>	<i>[Signature]</i>
Revision 'B'	May 1991	<i>[Signature]</i>	<i>[Signature]</i>

**ESC**ESA/SCC Detail Specification
No. 3401/004

Rev. 'B'

PAGE 2

ISSUE 1

DOCUMENTATION CHANGE NOTICE

Rev. Letter	Rev. Date	Reference	CHANGE Item	Approved DCR No.
'A'	Dec. '86	P1. Cover Page P2. DCN P7. Table 1(b)	: Item 1, Voltage Proof changed to Rated Voltage	None None 22493
'B'	May '91	P1. Cover Page P2. DCN P5. Para. 1.1 P12. Para. 2.	: Title amended : Reference to other specifications amended (in particular addition of ESA/SCC No. 3401/002) : Reference to other specifications amended (in particular addition of ESA/SCC No. 3401/002)	23436 None 23436 23436
		This document has been transferred from hardcopy to electronic format. The content is unchanged but minor differences in presentation exist.		



TABLE OF CONTENTS

	<u>Page</u>
1. <u>GENERAL</u>	5
1.1 Scope	5
1.2 Type Variants	5
1.3 Maximum Ratings	5
1.4 Parameter Derating Information	5
1.5 Physical Dimensions	5
1.6 Functional Diagram	5
2. <u>APPLICABLE DOCUMENTS</u>	12
3. <u>TERMS, DEFINITIONS, ABBREVIATIONS, SYMBOLS AND UNITS</u>	12
4. <u>REQUIREMENTS</u>	12
4.1 General	12
4.2 Deviations from Generic Specification	13
4.2.1 Deviations from Special In-process Controls	13
4.2.2 Deviations from Final Production Tests	13
4.2.3 Deviations from Burn-in and Electrical Measurements	13
4.2.4 Deviations from Qualification, Environmental and Endurance Tests	13
4.2.5 Deviations from Lot Acceptance Tests	13
4.3 Mechanical Requirements	13
4.3.1 Dimension Check	13
4.3.2 Weight	13
4.3.3 Cable Retention Force	14
4.3.4 Gold Plate Thickness	14
4.3.5 Contact Insertion and Withdrawal Forces	14
4.3.6 Female Contact Capability	15
4.3.7 Oversize Pin Exclusion	15
4.3.8 Probe Damage Test	15
4.3.9 Contact Retention	15
4.4 Materials and Finishes	15
4.4.1 Inner and Outer Contacts	16
4.4.2 Insert	16
4.5 Marking	16
4.5.1 General	16
4.5.2 The SCC Component Number	16
4.5.3 Traceability Information	16



	<u>Page</u>
4.6 Electrical Measurements	17
4.6.1 Electrical Measurements at Room Temperature	17
4.6.2 Electrical Measurements at High and Low Temperatures	17
4.6.3 Circuits for Electrical Measurements	17
4.7 Screening Tests	17
4.8 Environmental and Endurance Tests	19
4.8.1 Measurements and Inspections on Completion of Environmental Tests	19
4.8.2 Measurements and Inspections at Intermediate Points during Endurance Tests	19
4.8.3 Measurements and Inspections on Completion of Endurance Tests	19
4.8.4 Conditions for Operating Life Tests	19
4.8.5 Electrical Circuits for Operating Life Tests	19
4.8.6 Conditions for High Temperature Storage Test	19

TABLES

1(a) Type Variants	6
1(b) Maximum Ratings	7
2 Electrical Measurements at Room Temperature	18
3 Not Applicable	
4 Not Applicable	
5 Not Applicable	
6 Measurements and Inspections on Completion of Environmental and Endurance Tests	20

FIGURES

1 Parameter Derating Information	8
2 Physical Dimensions	9
3 Test Circuit for Contact Resistance Measurement	18

APPENDICES (Applicable to specific Manufacturers only)

None.

**1. GENERAL****1.1 SCOPE**

This specification details the ratings, physical and electrical characteristics, test and inspection data for Coaxial Contacts, Crimp-type and Solder-type, for 3401/001 Connectors.

It shall be read in conjunction with

- ESA/SCC Generic Specification No. 3401, Connectors, Electrical, Circular and Rectangular.
- ESA/SCC Detail Specification No. 3401/001, Connectors, Electrical, Rectangular, Miniature, Non-removable Solder and Wire-wrap Type Contacts and Removable Coaxial and Power Crimp-Type and Solder-Type Contacts, Based on Type D*M and
- ESA/SCC Detail Specification No. 3401/002, Connectors, Electrical, Rectangular, Miniature, Removable Crimp-Type Contacts and Removable Coaxial and Power Crimp-Type and Solder-Type Contacts, Based on Type D*MA,

the requirements of which are supplemented herein.

These contacts are not mounted in the connectors and are therefore delivered separately.

1.2 TYPE VARIANTS

Variants of the basic types of contacts specified herein, which are also covered by this specification, are given in Table 1(a).

1.3 MAXIMUM RATINGS

The maximum ratings, which shall not be exceeded at any time during use or storage, applicable to the contacts specified herein, are scheduled in Table 1(b).

1.4 PARAMETER DERATING INFORMATION

The derating information applicable to the contacts specified herein is shown in Figure 1.

1.5 PHYSICAL DIMENSIONS

The physical dimensions of the contacts specified herein are shown in Figure 2.

1.6 FUNCTIONAL DIAGRAM

Not applicable.

**TABLE 1(a) - TYPE VARIANTS**

VARIANT	TYPE	REAR END	MAX. WEIGHT (g)	ACCEPTED CABLES (NOTE 1)	ASSEMBLY METHOD BRAID/SLEEVE
01	Male	Straight	1.4	RG 178 B U RG 196 A U KX 21 A	Solder
02	Female	Straight	1.5		Solder
03	Male	90°	2.0		Solder
04	Female	90°	2.2		Solder
05	Male	Straight	1.4	KX 22 A RG 179 B U RG 316 U RG 188 A U 50 CIS	Solder
06	Female	Straight	1.5		Solder
07	Male	90°	2.0		Solder
08	Female	90°	2.2		Solder
09	Male	Straight	1.5	RG 180 B U	Solder
10	Female	Straight	1.7		Solder
11	Male	Straight	1.4	RG 178 B U RG 196 A U KX 21 A	Crimp
12	Female	Straight	1.5		Crimp
13	Male	90°	2.0		Crimp
14	Female	90°	2.2		Crimp
15	Male	Straight	1.4	KX 22 A RG 179 B U RG 316 U RG 188 A U 50 CIS	Crimp
16	Female	Straight	1.5		Crimp
17	Male	90°	2.0		Crimp
18	Female	90°	2.2		Crimp
19	Male	Straight	1.5	RG 180 B U	Crimp
20	Female	Straight	1.7		Crimp

NOTES

1. 50 CIS in accordance with ESA/SCC Detail Specification No. 3902/001.

RG 178 B/U
RG 196 A/U
RG 179 B/U
RG 316 U
RG 188 A/U
RG 180 B/U

} in accordance with MIL-C-17.

KX 21A/22A in accordance with NFC 93550.



TABLE 1(b) - MAXIMUM RATINGS

No.	CHARACTERISTICS	SYMBOL	MAXIMUM RATINGS	UNIT	REMARKS
1	Rated Voltage	U_R	See Figure 1	V	
2	Current Centre Contact	I_{CR}	7.5	A	Note 3
4	Frequency Range	f	up to 1.0	GHz	
5	VSWR up to 1.0GHz	-	1.4	-	Note 1
6	RF Insertion Loss at 1.0GHz	-	0.2	dB	Note 2
7	Operating Temperature Range	T_{op}	- 55 to + 125	°C	
8	Storage Temperature Range	T_{stg}	- 55 to + 125	°C	
9	Soldering Temperature	T_{sol}	+ 260	°C	Note 4

NOTES

1. ESA/SCC Generic Specification No. 3402, Para. 9.16.
2. ESA/SCC Generic Specification No. 3402, Para. 9.19.
3. May be limited by cable current-carrying capability.
4. 10 seconds maximum.



FIGURE 1 - PARAMETER DERATING INFORMATION

Voltage Proof versus Altitude

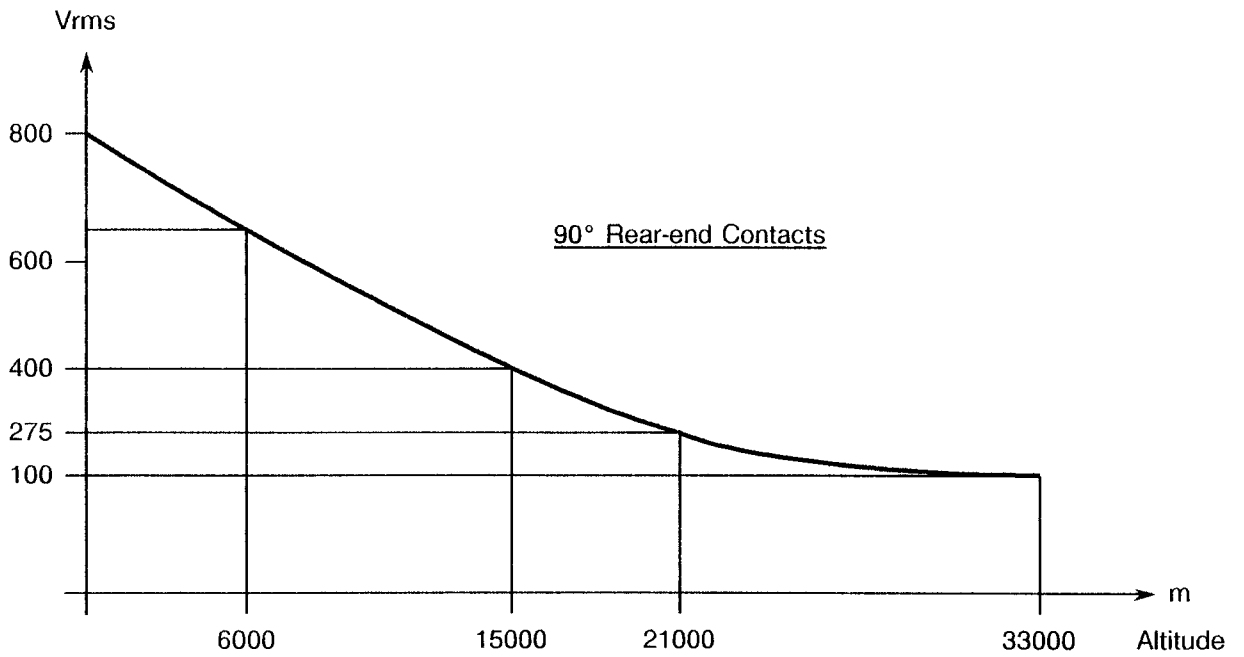
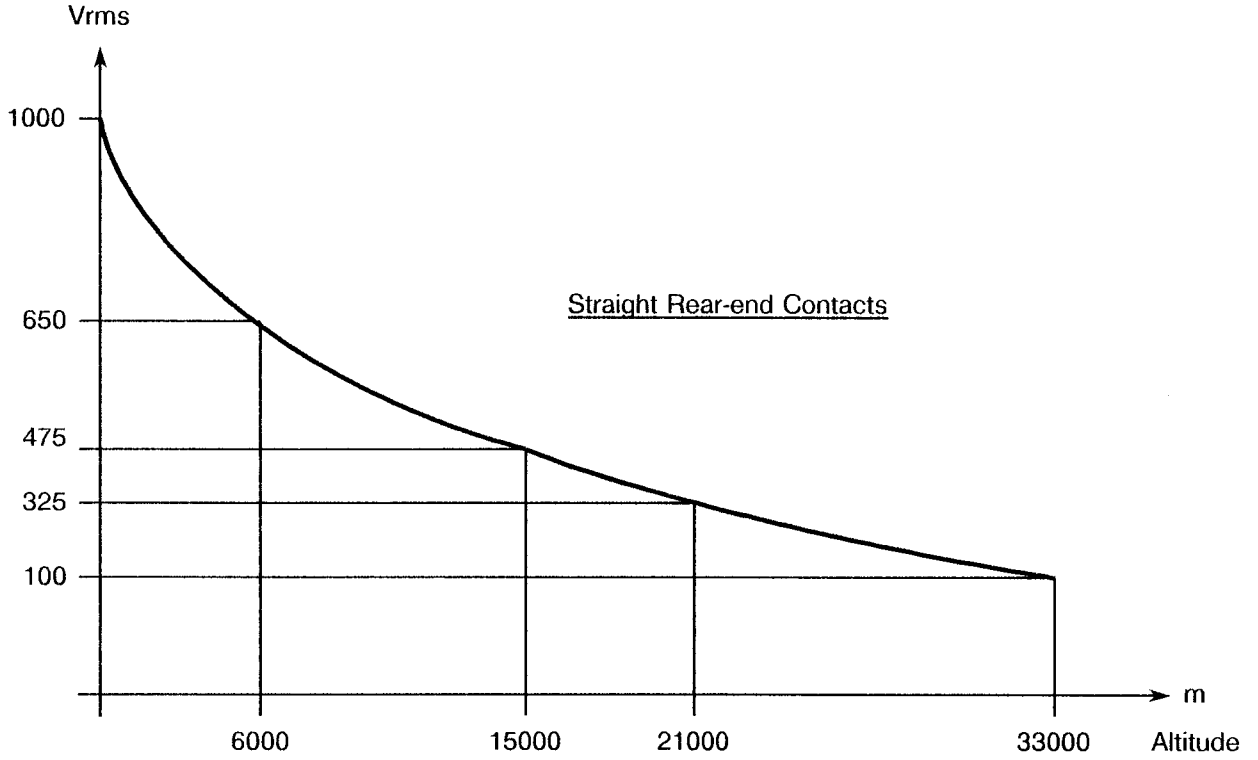
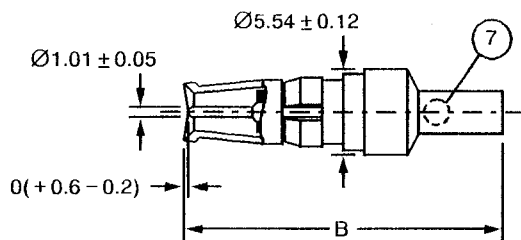



FIGURE 2 - PHYSICAL DIMENSIONS

**Female Coaxial Contact
(Male Centre Contact)**



Variants 02, 06, 12, 16

**Male Coaxial Contact
(Female Centre Contact)**

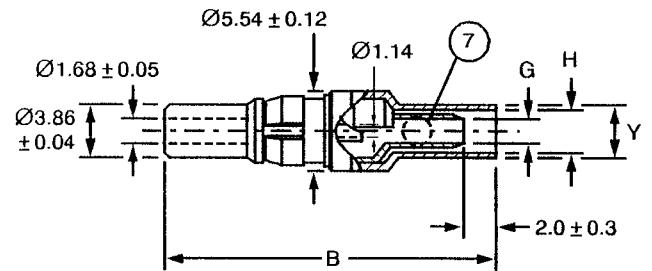

Variants 01, 05, 11, 15

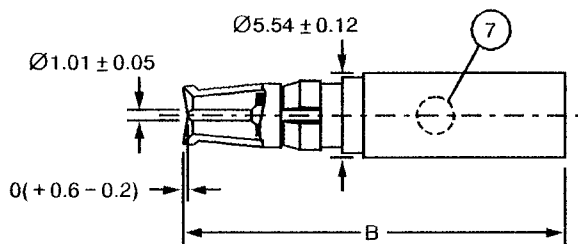

Variants 10, 20

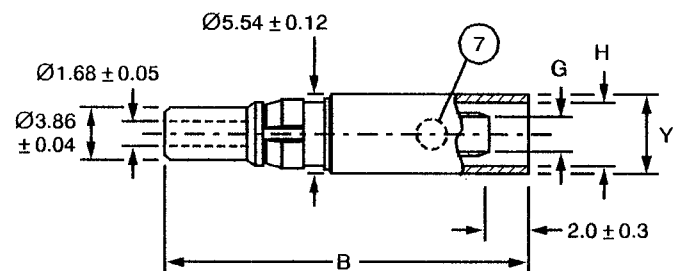

Variants 09, 19

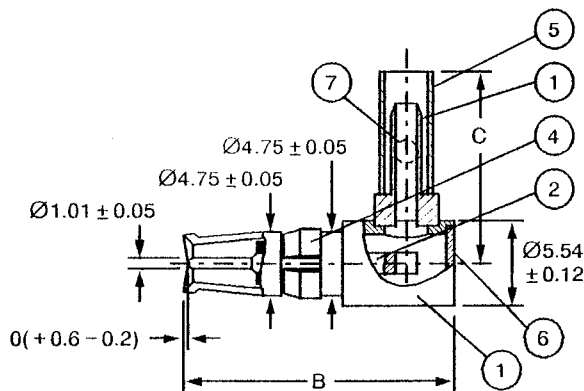

Variants 04, 08, 14, 18

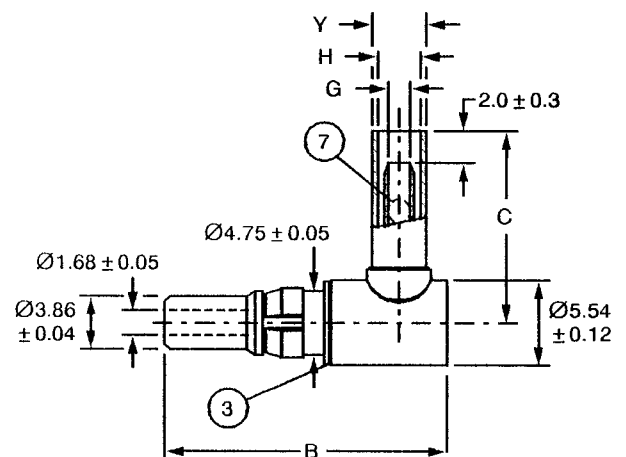

Variants 03, 07, 13, 17

1. Outer contact.
2. Centre contact
3. Washer.
4. Ring.
5. Sleeve.
6. Cap.
7. Vent hole for solder (Variants 01 to 10 only).

Dimensions in millimetres. For lettered dimensions, see Table on Page 11.



FIGURE 2 - PHYSICAL DIMENSIONS (CONTINUED)

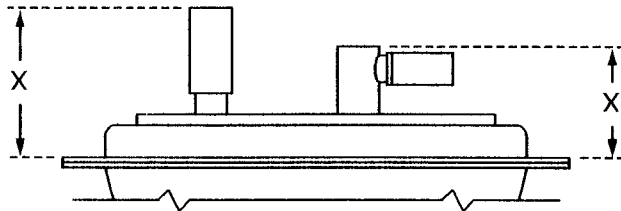

Maximum protrusion of contacts relative to rear of shell flange
See Page 11 for value of X.

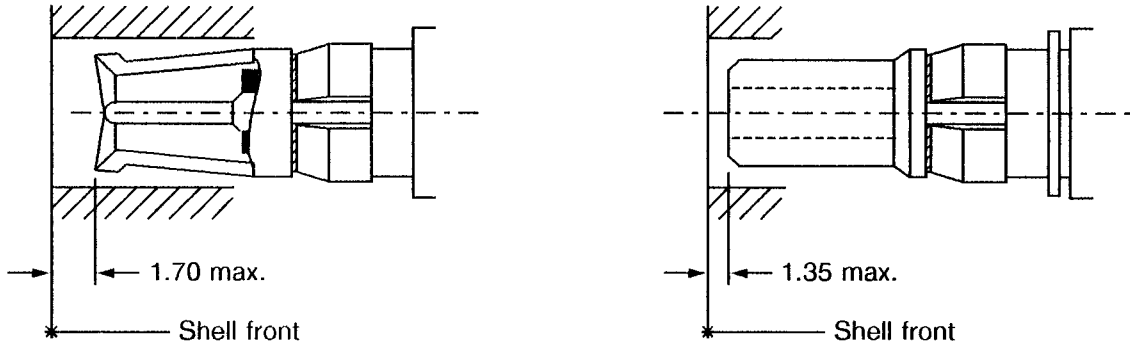

Maximum recess of contacts relative to front of shell

Dimensions in millimetres. For lettered dimensions, see table on Page 11.

**FIGURE 2 - PHYSICAL DIMENSIONS (CONTINUED)**

Dimensions in millimetres

VARIANTS	B Ref.	C Ref.	ØG Min.	ØH Min.	X Max.	ØY Max.
01, 11	23.60	-	0.90	2.30	18.80	3.25
02, 12	23.60	-	0.90	2.30	18.80	3.25
03, 13	18.64	12.50	0.90	2.30	13.46	3.25
04, 14	18.64	12.50	0.90	2.30	13.46	3.25
05, 15	23.60	-	1.55	3.10	18.80	4.10
06, 16	23.60	-	1.55	3.10	18.80	4.10
07, 17	18.64	12.50	1.55	3.10	13.46	4.10
08, 18	18.64	12.50	1.55	3.10	13.46	4.10
09, 19	26.30	-	2.55	5.10	21.50	6.20
10, 20	26.30	-	2.55	5.10	21.50	6.20

**2. APPLICABLE DOCUMENTS**

The following documents form part of this specification and shall be read in conjunction with it:-

- (a) ESA/SCC Generic Specification No. 3401, Electrical Connectors, Circular and Rectangular.
- (b) ESA/SCC Detail Specification No. 3401/001, Connectors, Electrical, Rectangular, Miniature, Non-removable Solder and Wire-wrap Type Contacts and Removable Coaxial and Power Crimp-Type and Solder-Type Contacts, Based on Type D*M.
- (c) ESA/SCC Detail Specification No. 3401/002, Connectors, Electrical, Rectangular, Miniature, Removable Crimp-Type Contacts and Removable Coaxial and Power Crimp-Type and Solder-Type Contacts, Based on Type D*MA.
- (d) ESA/SCC Generic Specification No. 3402, Connectors, RF Coaxial.
- (e) ESA/SCC Basic Specification No. 20534, External Visual Inspection of Electrical Connectors.
- (f) ESA/SCC Detail Specification No. 3902/001, Coaxial Cables, Radio Frequency, Flexible, 50 Ohms, Miniature, PTFE Dielectric, Polyimide Jacket, Based on Type 50 CIS.
- (g) MIL-G-45204, Gold Plating, Electro-deposited.
- (h) MIL-C-14550, Copper Plating, Electro-deposited.
- (i) MIL-C-17, General Specification for Cables, Radio Frequency, Flexible and Semi-rigid.
- (j) NFC 93550, Câbles Coaxiaux, HF Sous Tresse Métallique: Prescriptions Générales.

3. TERMS, DEFINITIONS, ABBREVIATIONS, SYMBOLS AND UNITS

For the purpose of this specification, the terms, definitions, abbreviations, symbols and units specified in ESA/SCC Basic Specification No. 21300 shall apply.

4. REQUIREMENTS**4.1 GENERAL**

The complete requirements for procurement of the contacts specified herein shall be as stated in this specification and ESA/SCC Generic Specification No. 3401. Deviations from the Generic Specification, applicable to this specification only, are listed in Para. 4.2.

Deviations from the applicable Generic Specification and this Detail Specification, formally agreed with specific Manufacturers on the basis that the alternative requirements are equivalent to the ESA/SCC requirements and do not affect the components' reliability, are listed in the appendices attached to this specification.



4.2 DEVIATIONS FROM GENERIC SPECIFICATION

4.2.1 Deviations from Special In-process Controls

None.

4.2.2 Deviations from Final Production Tests (Chart II)

(a) Voltage Proof shall be measured as specified in Table 2.

4.2.3 Deviations from Burn-in and Electrical Measurements (Chart III)

Not applicable.

4.2.4 Deviations from Qualification, Environmental and Endurance Tests (Chart IV)

(a) Para. 9.21, Oversize Pin Exclusion: Not applicable.

(b) Para. 9.24, Probe Damage Test: Not applicable.

(c) Para. 9.27, Solderability: Not applicable.

(d) Para. 9.29, Crimp Tensile Strength or Pull Test: Not applicable. Instead, a Cable Retention Force test shall be performed as specified in Para. 4.3.3.

(e) Voltage Proof shall be measured as and when specified in Table 6.

4.2.5 Deviations from Lot Acceptance Tests (Chart V)

Same deviations as listed in Para. 4.2.4 above are applicable.

4.3 MECHANICAL REQUIREMENTS

4.3.1 Dimension Check

The dimensions of the contacts specified herein shall be verified in accordance with the requirements set out in Para. 9.11 of ESA/SCC Generic Specification No. 3401 and shall conform to those shown in Figure 2.

4.3.2 Weight

The maximum weight of the contacts specified herein shall be as specified in Table 1(a).



4.3.3 Cable Retention Force

- (a) The contact shall be assembled to its test cable as specified in Table 1(a). It shall be firmly fixed and a movable sleeve or equivalent attached to the cable. The sleeve shall then be moved away from the fixed contact longitudinally and gradually, and in such a manner that the cable remains unbent and untwisted. A scale for measuring the retention force shall be attached to the sleeve. The force shall be maintained for 30 seconds minimum.
- (b) The assembly, still under tension, shall be tested for contact resistance (inner and outer contacts) and shall then be examined for mechanical failure, loosening or rupture.
- (c) With the contact still in the fixed position, the cable shall be held at a point 50 times the diameter of the cable from the contact and a torque shall be applied in both directions up to an angle of 90°.
- (d) The cable shall then be bent at a radius of 10 times the diameter of the cable, starting at the contact, at an angle of 90 ± 5° from the axis of the contact, then reversed 180 ± 10°.

This procedure shall be repeated 4 times prior to retest and re-examination as specified in item (b) above.

4.3.4 Gold Plate Thickness

The thickness of the gold plate deposited on the contacts specified herein shall be 2.5 microns minimum of gold over 1.0 micron of copper.

4.3.5 Contact Insertion and Withdrawal Forces

4.3.5.1 Outer Contacts (Variants 02, 04, 06, 08, 10, 12, 14, 16, 18, 20)

The contact insertion forces shall be as specified hereunder:-

Test Pin Diameter (mm)	Insertion (g)	
	Min.	Max.
3.857 - 3.862	85	700

4.3.5.2 Centre Contacts (Variants 01, 03, 05, 07, 09, 11, 13, 15, 17, 19)

The contact insertion and withdrawal forces shall be as specified hereunder:-

Test Pin Diameter (mm)	Insertion (g)	
	Min.	Max.
0.990 - 0.993	28.35	28.35
1.039 - 1.042	340.00	226.80

**4.3.6 Female Contact Capability (Variants 01, 03, 05, 07, 09, 11, 13, 15, 17, 19)**

For the purpose of this test, the pick-up and drop weights shall be as follows:-

4.3.6.1 Outer Contacts (Variants 02, 04, 06, 08, 10, 12, 14, 16, 18, 20)

	Pick-up Weight	Drop Weight
Weight (g)	85	700
Pin Diameter (mm)	3.857 - 3.862	3.857 - 3.862
Insertion Depth (mm)	4.0	4.0

4.3.6.2 Centre Contacts (Variants 01, 03, 05, 07, 09, 11, 13, 15, 17, 19)

	Pick-up Weight	Drop Weight
Weight (g)	28.35	226.80
Pin Diameter (mm)	0.990 - 0.993	1.039 - 1.042
Insertion Depth (mm)	4.0	4.0

4.3.7 Oversize Pin Exclusion

Not applicable.

4.3.8 Probe Damage Test

Not applicable.

4.3.9 Contact Retention

Contact retention within the insert shall be 40.86N. There shall be no displacement of the contact in excess of 0.3mm.

4.4 MATERIALS AND FINISHES

The materials and finishes shall be as specified herein. Where a definite material is not specified, a material which will enable the contacts specified herein to meet the performance requirements of this specification shall be used. Acceptance or approval of any constituent material does not guarantee acceptance of the finished product.



4.4.1 Inner and Outer Contacts

The contacts shall be made of copper base alloy selected from raw materials with a minimum of impurities. The contacts shall be plated as specified in MIL-G-45204, Type II, Grade 'C', over copper in accordance with MIL-C-14550.

4.4.2 Insert

Teflon, unpigmented.

4.5 MARKING

4.5.1 General

The marking of all components delivered to this specification shall be in accordance with the requirements of ESA/SCC Basic Specification No. 21700 and the following paragraphs. These components being too small to accommodate the marking as specified hereafter, the full marking information shall accompany each lot of components in its primary package. Such marking shall comprise:-

- (a) The SCC Component Number.
- (b) Traceability Information.
- (c) Quantity of Components.

4.5.2 The SCC Component Number

The SCC Component Number shall be constituted and marked as follows:

Detail Specification Number _____ 340100401B
Type Variant, as applicable (see Table 1(a)) _____
Testing Level _____

4.5.3 Traceability Information

Traceability information shall be marked in accordance with ESA/SCC Basic Specification No. 21700.



4.6 ELECTRICAL MEASUREMENTS

4.6.1 Electrical Measurements at Room Temperature

The parameters to be measured in respect of electrical characteristics are scheduled in Table 2. Unless otherwise specified, the measurements shall be performed at $T_{amb} = +22 \pm 3$ °C.

Contact resistance shall be measured of both the engaged outer and inner conductor contacts.

4.6.2 Electrical Measurements at High and Low Temperatures (Table 3)

Not applicable.

4.6.3 Circuits for Electrical Measurements

Circuits for use in performing the electrical measurements shown in Table 2 of this specification are shown in Figure 3.

4.7 SCREENING TESTS (TABLES 4 AND 5)

Not applicable.



TABLE 2 - ELECTRICAL MEASUREMENTS AT ROOM TEMPERATURE

No.	CHARACTERISTICS	SYMBOL	ESA/SCC GEN. SPEC. 3401	TEST CONDITIONS	LIMITS		UNIT
					MIN.	MAX.	
1	Contact Resistance Low Level Current Centre and Outer Contact	R_C	Para. 9.28.2	Figure 3	-	8.5	$m\Omega$
2	Contact Resistance Rated Level Current Centre Contact	R_C	Para. 9.28.2	Figure 3	-	7.0	$m\Omega$
3	Voltage Proof Centre/Outer Contact Straight Rear End	V_P	Para. 9.2	-	-	1000	Vrms
4	Voltage Proof Centre/Outer Contact 90° Rear End	V_P	Para. 9.2	-	-	800	Vrms

TABLES 3, 4 AND 5

Not applicable.

FIGURE 3 - TEST CIRCUIT FOR CONTACT RESISTANCE MEASUREMENT

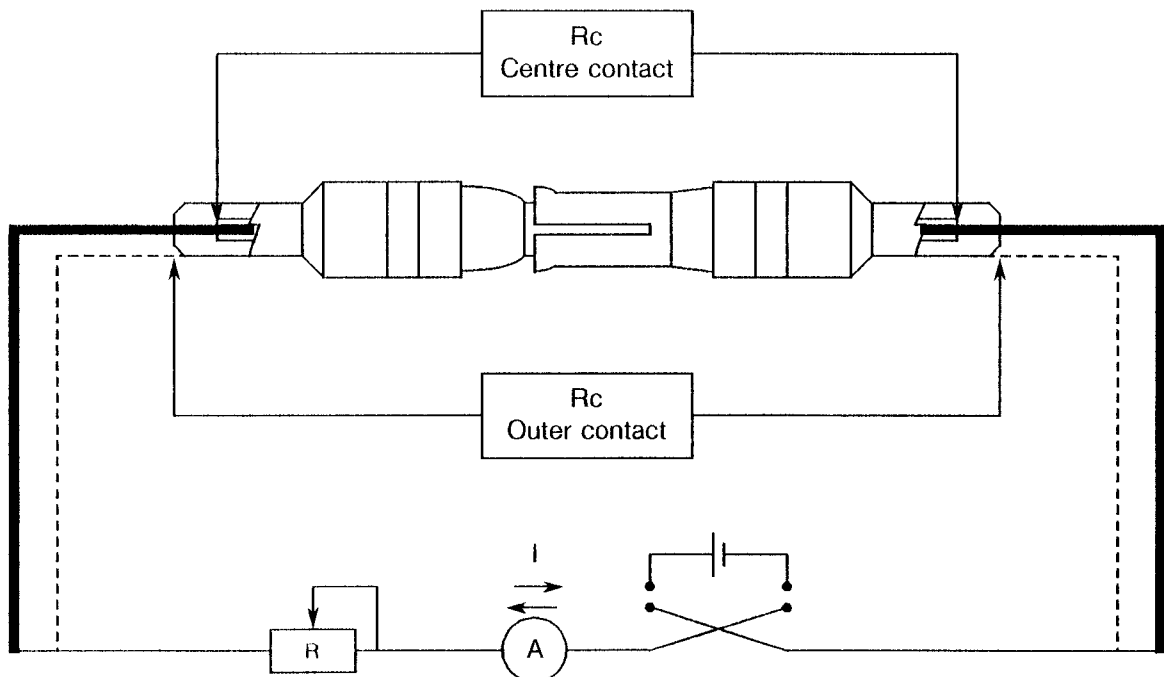



4.8 ENVIRONMENTAL AND ENDURANCE TESTS

4.8.1 Measurements and Inspections on Completion of Environmental Tests

The parameters to be measured on completion of environmental tests shall be those specified in the test sequence of ESA/SCC Generic Specification No. 3401. Unless otherwise stated, the measurements shall be performed at $T_{amb} = +22 \pm 3 \text{ }^{\circ}\text{C}$.

4.8.2 Measurements and Inspections at Intermediate Points during Endurance Tests

Not applicable.

4.8.3 Measurements and Inspections on Completion of Endurance Tests

The parameters to be measured on completion of endurance tests shall be those specified in the test sequence of ESA/SCC Generic Specification No. 3401. Unless otherwise stated, the measurements shall be performed at $T_{amb} = +22 \pm 3 \text{ }^{\circ}\text{C}$.

4.8.4 Conditions for Operating Life Tests (Part of Endurance Testing)

Not applicable.

4.8.5 Electrical Circuits for Operating Life Tests

Not applicable.

4.8.6 Conditions for High Temperature Storage Test (Part of Endurance Testing)

Not applicable.



TABLE 6 - MEASUREMENTS AND INSPECTIONS ON COMPLETION OF ENVIRONMENTAL AND ENDURANCE TESTS

No.	ESA/SCC GENERIC SPECIFICATION NO. 3401		MEASUREMENTS AND INSPECTIONS		SYMBOL	LIMITS		UNIT
	ENVIRONMENTAL AND ENDURANCE TESTS (1)	TEST METHOD AND CONDITIONS	IDENTIFICATION	CONDITIONS		MIN.	MAX.	
01	Female Contact Capability	Para. 9.6	Pick-up Weight Drop Weight	Para. 4.3.6 Para. 4.3.6	- -	Pick-up Drop		- -
02	Oversize Pin Exclusion	Para. 9.21	Not applicable	-	-	-	-	-
03	Gold Plate Thickness	Para. 9.22	Gold Plate Thickness	Para. 4.3.4	-	-	-	-
04	Gold Plate Porosity	Para. 9.23	Visual Examination	Within 15 seconds	-	No bubbles		-
05	Contact Insertion and Withdrawal Forces	Para. 9.25	Forces	Para. 4.3.5	-	Para. 4.3.5		-
06	Probe Damage Test	Para. 9.24	Not applicable	-	-	-	-	-
07	Crimp Visual Inspection	Para. 9.26	Visual Examination	-	-	-	-	-
08	Solderability	Para. 9.27	Not applicable	-	-	-	-	-
09	Contact Resistance	Para. 9.28	Contact Resistance	Centre & Outer Contacts: Low Level Table 2 Item 1 Centre Contact: Rated Level Table 2 Item 2	R _C R _C	Table 2 Item 1 Table 2 Item 2	- -	
10	Crimp Tensile Strength	Para. 9.29	Not applicable	-	-	-	-	-
11	Pull Test	Para. 9.29	Not applicable	-	-	-	-	-
12	Endurance	Para. 9.15	Centre & Outer Contacts Contact Resistance Drift Contact Resistance Voltage Proof	Low Level Table 2 Item 1 Low Level Table 2 Item 1 Table 2 Items 3 & 4	ΔR_C R _C V _P	- - Table 2 Items 3 & 4	2.0 8.5 -	m Ω m Ω -
13	High Temperature Storage	Para. 9.19	Centre & Outer Contacts Contact Resistance Drift Contact Resistance Voltage Proof	Low Level Table 2 Item 1 Low Level Table 2 Item 1 Table 2 Items 3 & 4	ΔR_C R _C V _P	- - Table 2 Items 3 & 4	2.0 8.5 -	m Ω m Ω -
14	Cable Retention Force	Para. 4.3.3 of this spec.	Contact Resistance Drift Visual Examination	Low Level Table 2 Item 1 -	ΔR_C -	No drift -		- -
15	Voltage Proof Altitude	Para. 9.12 33000M	Voltage Proof	Table 2 Items 3 & 4	V _P	See Figure 1		-

NOTES

1. The tests in this table refer to either Chart IV or V and shall be used as applicable.