



europaean space agency
agence spatiale européenne

Pages 1 to 24

**CONNECTORS, MINIATURE, ELECTRICAL,
CIRCULAR, PUSH-PULL COUPLING,
REMOVABLE CRIMP CONTACTS,
BASED ON TYPE DBAS**

ESA/SCC Detail Specification No. 3401/008



**space components
coordination group**



Issue/Rev.	Date	Approved by	
		SCCG Chairman	ESA Director General or his Deputy
Issue 5	May 1998		
Revision 'A'	March 2002		

**DOCUMENTATION CHANGE NOTICE**

Rev. Letter	Rev. Date	Reference	CHANGE Item	Approved DCR No.
		This Issue supersedes Issue 4 and incorporates all modifications defined in Revisions 'A', 'B', 'C', 'D', 'E' and 'F' to Issue 4 and the changes agreed in the following DCRs:-		
		Cover page	: Title amended	221409
		DCN		None
		Para. 1.1	: First 2 specifications, Titles amended	221409
			: 3rd specification deleted and 2 new specifications added	221409
		Para. 1.2	: In the text, "the basic type" deleted	221409
		Table 1(a)	: 4th and 5th Column Headings amended	221409
		Second Table 1(a)	: Title corrected to "1(b)"	221409
			: No. 1, Characteristics amended, Min. Limit deleted and new Max. Limit added	221409
		Figure 1	: Subtitle and Figure amended	221409
		Figure 2	: For all Shell Sizes, dimensions amended in Drawings and Tables	221409
		Figure 2(a)	: Existing Note deleted and new Note added	221409
		Figure 2(b)	: Contact arrangements "27-11" and "27-25" deleted	221409
			: Contact arrangements "61-42" and "61-949" added	221409
			: Existing Note deleted and new Note added	221409
		Figure 2(c)	: In the Table, contact arrangements "27-11" and "27-25" deleted and "61-42" and "61-949" added	221409
		Para. 2	: Items (a) and (b) amended	221409
			: Item (c) deleted and new Items (c), (d) and (e) added	221409
		Para. 4.4.2	: In the first Deviation, "9.7" amended to "9.5"	221409
		Para. 4.2.4	: In the first Deviation, "9.9" amended to "9.11"	221409
			: In the second Deviation, "9.9" amended to "9.12"	221409
			: Third Deviation deleted	221409
			: In the fourth Deviation, "9.15" amended to "9.18"	221409
			: Deviations for Paras. "9.9" and "9.24" added	221409
		Para. 4.3.1	: In the text, paragraph reference amended	221409
		Para. 4.3.3	: Title and text amended and renumbered as "4.3.5"	221409/ 23886
		Para. 4.3.4	: Title and text amended	221409
		Para. 4.3.5	: Title amended and renumbered as "4.3.6"	221409/ 23886
		Paras. 4.3.6	: New paragraph added and renumbered as "4.3.3"	221409/ 23886
		Paras. 4.3.7 to 4.3.12	: New paragraphs added	221409
		Para. 4.4.1	: Title amended and in the text, paragraph reference amended	221409
		Paras. 4.4.3 to 4.4.6	: New paragraphs added	221409
		Para. 4.5.1	: Text amended	221409
		Para. 4.5.2	: New paragraph "4.5.2" added	221409
			: Existing paragraph renumbered as "4.5.3"	221409
		Para. 4.5.3	: Renumbered as "4.5.4"	221409
			: In the text, second "shall" deleted	221409
		Para. 4.5.3.1	: Renumbered as "4.5.4.1"	221409
		Para. 4.5.3.2	: Renumbered as "4.5.4.2"	221409
		Para. 4.5.3.3	: Renumbered as "4.5.4.3"	221409
		Para. 4.5.3.4	: Renumbered as "4.5.4.4"	221409
			: In the Table, contact arrangements "27-11" and "27-25" deleted and "61-42" and "61-949" added	221409
		Paras. 4.5.3.5 to 4.5.3.8	: Renumbered as "4.5.4.5" to "4.5.4.8" respectively	221409

**TABLE OF CONTENTS**

	<u>Page</u>
1. <u>GENERAL</u>	5
1.1 Scope	5
1.2 Range of Components	5
1.3 Maximum Ratings	5
1.4 Parameter Derating Information	5
1.5 Physical Dimensions	5
2. <u>APPLICABLE DOCUMENTS</u>	5
3. <u>TERMS, DEFINITIONS, ABBREVIATIONS, SYMBOLS AND UNITS</u>	5
4. <u>REQUIREMENTS</u>	14
4.1 General	14
4.2 Deviations from Generic Specification	14
4.2.1 Deviations from Special In-process Controls	14
4.2.2 Deviations from Final Production Tests	14
4.2.3 Deviations from Burn-in and Electrical Measurements	14
4.2.4 Deviations from Qualification Tests	14
4.2.5 Deviations from Lot Acceptance Tests	14
4.3 Mechanical Requirements	15
4.3.1 Dimension Check	15
4.3.2 Weight	15
4.3.3 Contact Capability	15
4.3.4 Contact Retention	15
4.3.5 Mating and Unmating Forces	15
4.3.6 Insert Retention	15
4.3.7 Jackscrew Retention	15
4.3.8 Contact Insertion and Withdrawal Forces	15
4.3.9 Engagement and Separation Forces	15
4.3.10 Oversize Pin Exclusion	15
4.3.11 Probe Damage	15
4.3.12 Solderability	15
4.4 Materials and Finishes	16
4.4.1 Shells, Coupling Ring and Nut	16
4.4.2 Inserts	16
4.4.3 Contacts	16
4.4.4 Contact Retaining Clip	16
4.4.5 Guiding and Locking Devices	16
4.4.6 Magnetism Level	16
4.5 Marking	16
4.5.1 General	16
4.5.2 Contact Identification	16
4.5.3 The SCC Component Number	17
4.5.4 Characteristics	17
4.5.5 Traceability Information	19
4.6 Electrical Measurements	20
4.6.1 Electrical Measurements at Room Temperature	20
4.6.2 Electrical Measurements at High and Low Temperatures	20
4.6.3 Circuits for Electrical Measurements	20
4.7 Burn-in and Electrical Measurements	20

		<p style="text-align: center;">ESA/SCC Detail Specification No. 3401/008</p>		<p>PAGE 4 ISSUE 5</p>
--	--	--	--	---------------------------

	<u>Page</u>
4.8 Environmental and Endurance Tests	21
4.8.1 Measurements and Inspections on Completion of Environmental Tests	21
4.8.2 Measurements and Inspections at Intermediate Points during Endurance Tests	21
4.8.3 Measurements and Inspections on Completion of Endurance Tests	21
4.8.4 Conditions for Operating Life Tests	21
4.8.5 Electrical Circuit for Operating Life Tests	21
4.8.6 Conditions for High Temperature Storage Test	21

TABLES



1(a) Range of Components	6
1(b) Maximum Ratings	6
2 Electrical Measurements at Room Temperature	20
3 Not Applicable	N/A
4 Not Applicable	N/A
5 Not Applicable	N/A
6 Measurements and Inspections on Completion of Environmental and Endurance Testing	22

FIGURES

1 Parameter Derating Information	7
2 Physical Dimensions	8

APPENDICES (Applicable to specific Manufacturers only)

None.

		<p style="text-align: center;">ESA/SCC Detail Specification No. 3401/008</p>	<p style="text-align: center;">Rev. 'A'</p>	<p>PAGE 5 ISSUE 5</p>
--	--	--	---	---------------------------

1. GENERAL

1.1 SCOPE

This specification details the ratings, physical and electrical characteristics, test and inspection data for Connectors, Miniature, Electrical, Circular, Push-Pull Coupling, Crimp Removable Contacts, based on Type DBAS.

It shall be read in conjunction with:

- ESA/SCC Generic Specification No.3401, Connectors, Electrical, Non-Filtered Circular and Rectangular
- ESA/SCC Detail Specification No. 3401/009, Contacts, Electrical, Crimp for 3401/007 and 3401/008 Connectors
- ESA/SCC Detail Specification No. 3401/012, Contacts, Electrical, Crimp for 3401/011 Connectors
- ESA/SCC Detail Specification No. 3401/033, Connector Savers, Electrical, Circular, Miniature, Non-Removable Contacts, Based on Type DBAS
- ESA/SCC Detail Specification No. 3401/064, Accessories for Circular Connectors 3401/008

the requirements of which are supplemented herein.

1.2 RANGE OF COMPONENTS

The different sizes of connectors specified herein, which are also covered by this specification, together with their mechanical characteristics, are given in Table 1(a).

1.3 MAXIMUM RATINGS

The maximum ratings, which shall not be exceeded at any time during use or storage, applicable to the connectors specified herein, are scheduled in Table 1(b).

1.4 PARAMETER DERATING INFORMATION

The applicable derating information for the connectors specified herein is shown in Figure 1.

1.5 PHYSICAL DIMENSIONS

The physical dimensions of the connectors specified herein, are shown in Figure 2.

2. APPLICABLE DOCUMENTS

The following documents form part of this specification and shall be read in conjunction with it:-

- (a) ESA/SCC Generic Specification No. 3401, Connectors, Electrical, Non-Filtered, Circular and Rectangular.
- (b) ESA/SCC Detail Specification No. 3401/009, Contacts, Electrical, Crimp for 3401/007 and 3401/008 Connectors.
- (c) ESA/SCC Detail Specification No. 3401/012, Contacts, electrical, Crimp for 3401/011 Connectors.
- (d) ESA/SCC Detail Specification No. 3401/033, Connector Savers, Electrical, Circular, Miniature, Non-Removable Contacts, Based on Type DBAS.
- (e) ESA/SCC Detail Specification No. 3401/064, Accessories for Circular Connectors 3401/008.
- (f) MIL-C-81703, Connectors, Electric, Circular, Miniature Rack and Panel or Push-Pull Coupling, Environment Resisting.

3. TERMS, DEFINITIONS, ABBREVIATIONS, SYMBOLS AND UNITS

For the purpose of this specification, the terms, definitions, abbreviations, symbols and units specified in ESA/SCC Basic Specification No. 21300 shall apply.



TABLE 1(a) - RANGE OF COMPONENTS

SHELL STYLE	SHELL SIZE	MAX. WEIGHT (g) (Note 1)	MATING FORCE (DaN. Max.)	UNMATING FORCE	
				DaN. Min.	DaN. Max.
Receptacle	3	16	-	-	-
Receptacle	7	22	-	-	-
Receptacle	12	27	-	-	-
Receptacle	19	34	-	-	-
Receptacle	27	45	-	-	-
Receptacle	37	51	-	-	-
Receptacle	61	73	-	-	-
Plug	3	24	6.8	0.54	6.8
Plug	7	31	8.9	0.66	8.9
Plug	12	38	15.1	0.89	15.1
Plug	19	49	16.9	1.33	16.9
Plug	27	53	17.8	1.78	17.8
Plug	37	71	19.6	2.67	19.6
Plug	61	99	21.8	3.11	21.8

NOTES

- Without contacts.

TABLE 1(b) - MAXIMUM RATINGS

No.	CHARACTERISTICS	SYMBOL	MAXIMUM RATINGS	UNIT	REMARKS
1	Working Voltage (sea level) contacts size 20, 16, 12, 08	U_R	375	Vrms	Note 1
	Working Voltage (sea level) contacts size 22	U_R	250	Vrms	Note 1
2	Operating Temperature Range	T_{op}	- 65 to + 200	°C	
3	Storage Temperature Range	T_{stg}	- 65 to + 200	°C	

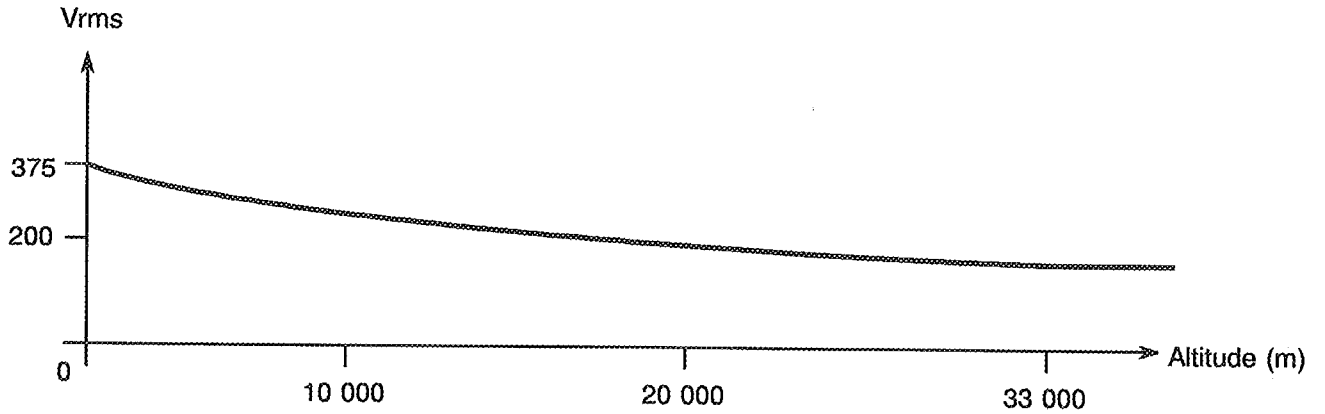
NOTES

- See Figure 1.



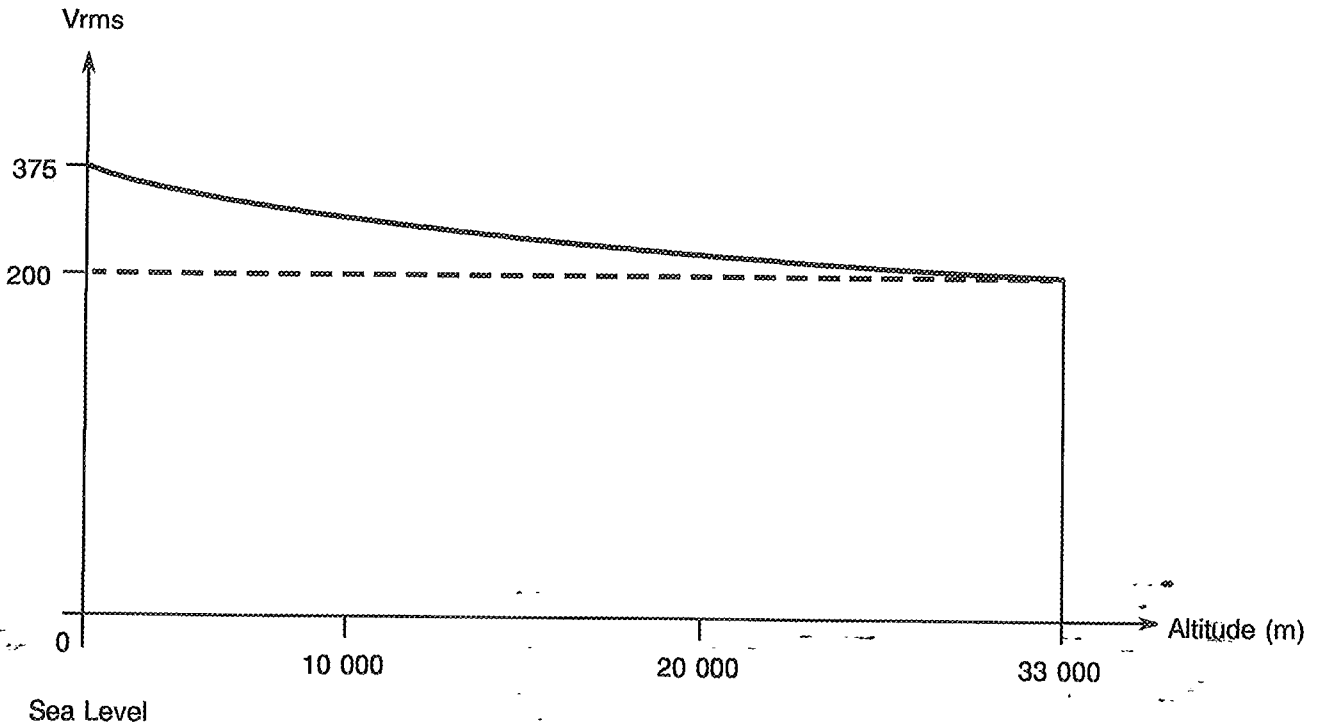
FIGURE 1 - PARAMETER DERATING INFORMATION

FIGURE 1(a) - CONTACT SIZE 08, 12, 16 and 20



Working Voltage versus Altitude

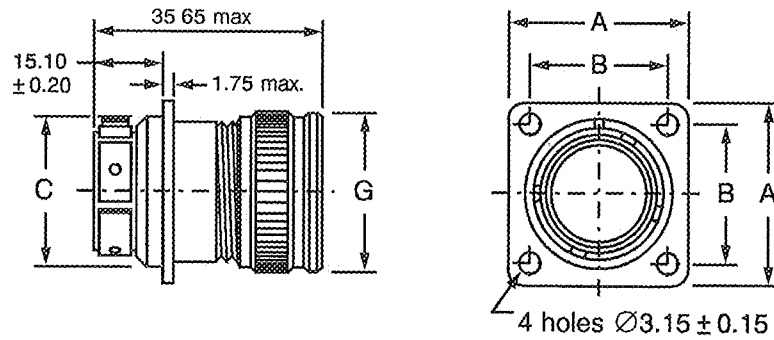
FIGURE 1(b) - CONTACT SIZE 22



Working Voltage versus Altitude

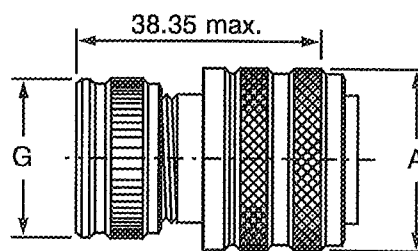


FIGURE 2 - PHYSICAL DIMENSIONS
SHELL TYPE 70 - SQUARE FLANGE RECEPTACLE



Shell Size	Dimensions (mm)			
	A max.	B ± 0.1	C max.	G max.
3	22.60	15.90	14.50	17.00
7	25.80	18.26	17.35	21.80
12	28.20	20.62	20.80	25.00
19	30.60	23.02	24.00	28.25
27	33.00	24.58	28.65	30.95
37	36.90	30.12	31.95	34.15
61	45.70	36.48	39.90	42.00

SHELL TYPE 76 - PLUG

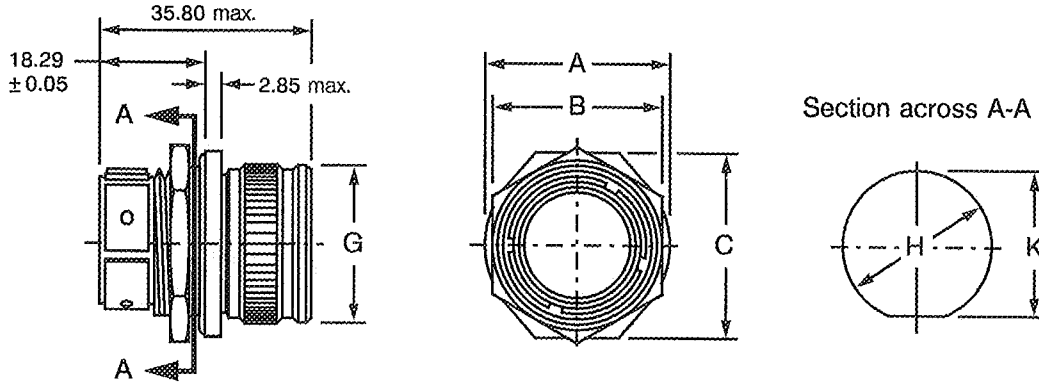


Shell Size	Dimensions (mm)	
	A max.	G max.
3	20.40	17.00
7	23.70	21.80
12	26.90	25.00
19	31.50	28.25
27	36.10	30.95
37	39.30	34.15
61	47.30	42.00



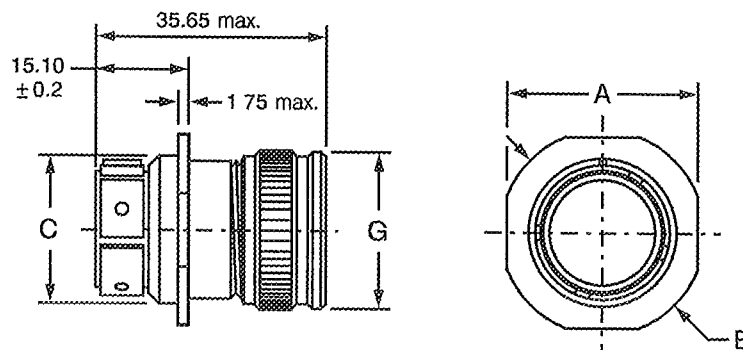
FIGURE 2 - PHYSICAL DIMENSIONS (CONTINUED)

SHELL TYPE 74 - SINGLE HOLE MOUNTING RECEPTACLE



Shell Size	Dimensions (mm)					
	A max.	B max.	C max.	G max.	H max.	K max.
3	19.20	16.31	19.20	17.00	14.35	13.45
7	22.40	21.07	22.40	21.80	17.50	16.80
12	27.20	24.24	27.20	25.00	20.65	19.95
19	30.40	27.40	29.60	28.25	25.45	24.65
27	33.60	32.18	33.50	30.95	28.60	27.85
37	38.30	35.36	36.30	34.15	31.80	31.00
61	47.80	43.02	47.20	42.00	38.10	37.30

SHELL TYPE 71 - CABLE CONNECTING RECEPTACLE

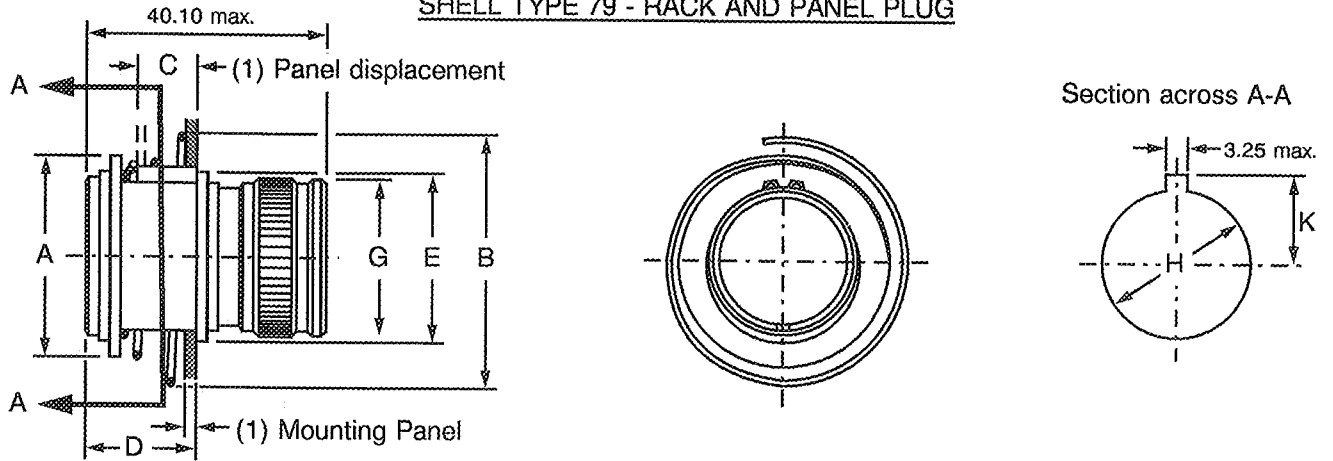


Shell Size	Dimensions (mm)			
	A max.	B max.	C max.	G max.
3	22.60	25.45	14.50	17.00
7	25.80	28.65	17.35	21.80
12	28.20	31.05	20.80	25.00
19	30.60	33.45	24.00	28.25
27	33.00	35.85	28.65	30.95
37	36.90	39.75	31.95	34.15
61	45.70	48.55	39.90	42.00



FIGURE 2 - PHYSICAL DIMENSIONS (CONTINUED)

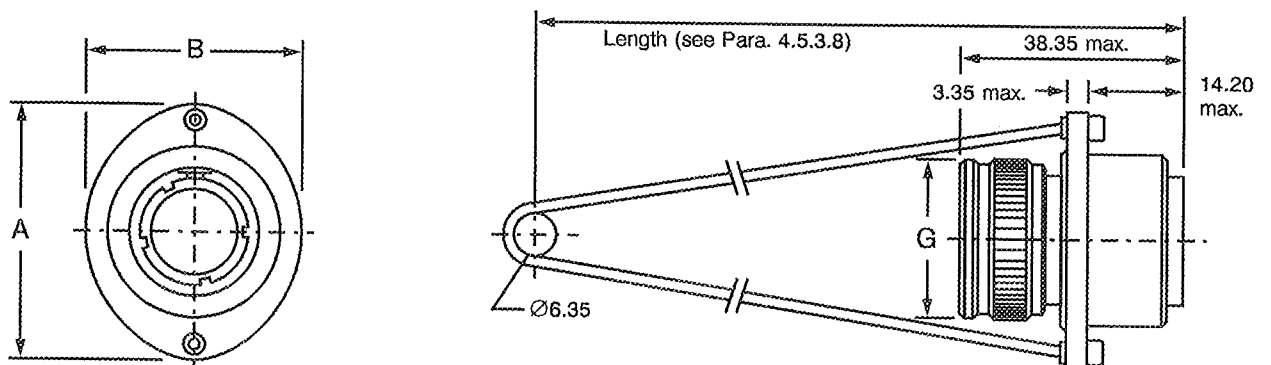
SHELL TYPE 79 - RACK AND PANEL PLUG



Shell Size	Dimensions (mm)									
	A max.	B max.	C (1) max.	Compression Force		D max.	E max.	G max.	H max.	K max.
				for C max.	for C nul					
3	22.45	31.00	14.95 - e	1.6DaN	0.3DaN	21.05	19.30	17.00	15.55	11.05
7	29.60	34.30	14.55 - e	3.3DaN	0.6DaN	20.85	24.40	21.80	19.05	12.60
12	31.90	39.75	13.95 - e	5.0DaN	1.2DaN	20.85	27.25	25.00	22.20	14.20
19	35.15	43.40	13.95 - e	8.7DaN	1.9DaN	20.85	32.00	28.25	25.40	16.05
27	38.70	47.15	13.25 - e	11.8DaN	2.7DaN	20.60	35.75	30.95	29.15	17.80
37	45.95	53.50	12.65 - e	15.6DaN	3.7DaN	20.60	40.60	34.15	33.50	20.00
61	54.40	72.00	11.60 - e	26.2DaN	6.1DaN	20.30	50.40	42.00	41.50	23.95

NOTES 1. The displacement of dimension C depends on the panel thickness used.

SHELL TYPE 78 - PLUG WITH LANYARD

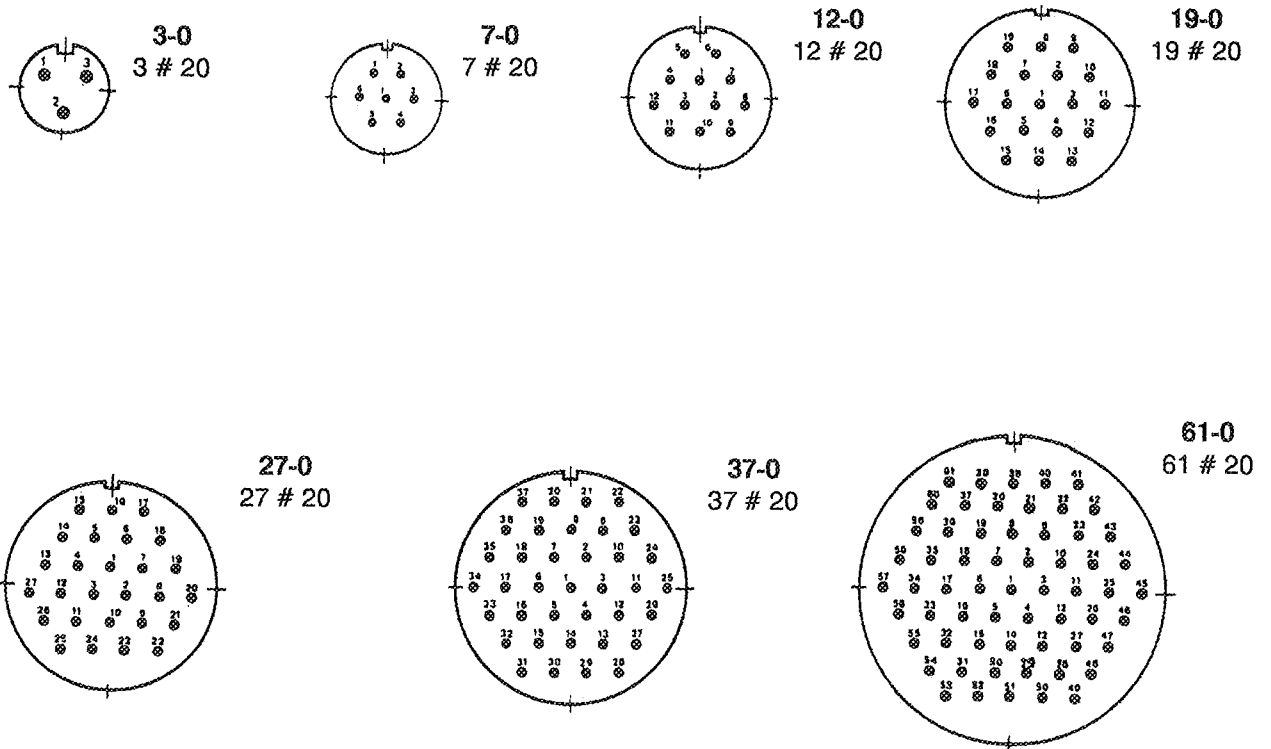


Shell Size	Dimensions (mm)		
	A max.	B max.	G max.
3	31.85	23.30	17.00
7	35.65	26.80	21.80
12	38.70	29.60	25.00
19	42.50	33.55	28.25
27	46.20	37.20	30.95
37	48.45	40.70	34.15
61	56.60	47.85	42.00



FIGURE 2 - PHYSICAL DIMENSIONS (CONTINUED)

FIGURE 2(a) - STANDARD CONTACT ARRANGEMENTS - FRONT VIEW MALE INSERT
(See Para. 4.5 for definition of numbers)



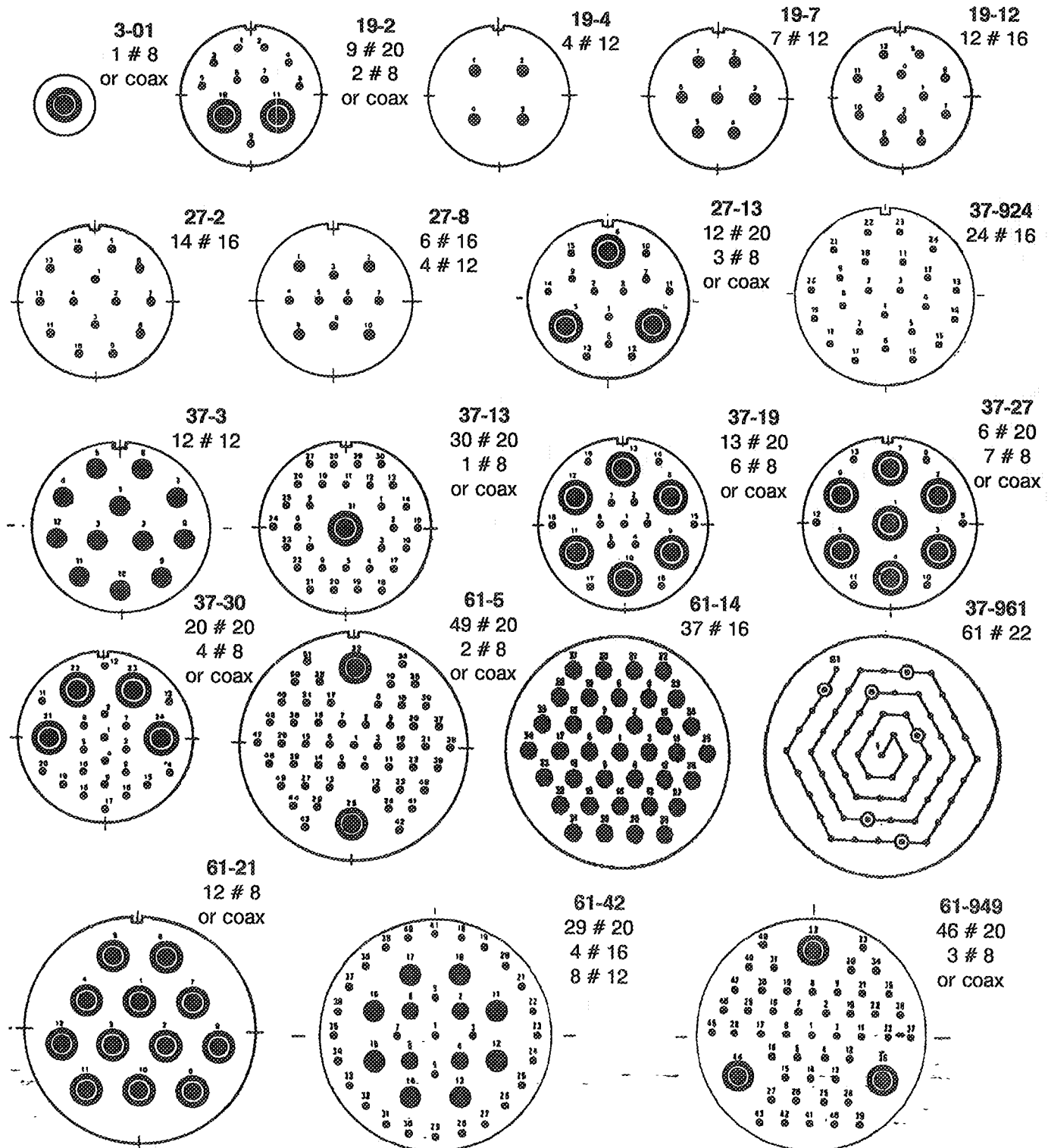
NOTES

1. Contact locations are in conformity with MIL-C-81703 specification sheets and shall not be checked during procurement.



FIGURE 2 - PHYSICAL DIMENSIONS (CONTINUED)

FIGURE 2(b) - SPECIAL CONTACT ARRANGEMENTS - FRONT VIEW MALE INSERT
(See Para. 4.5 for definition of numbers)



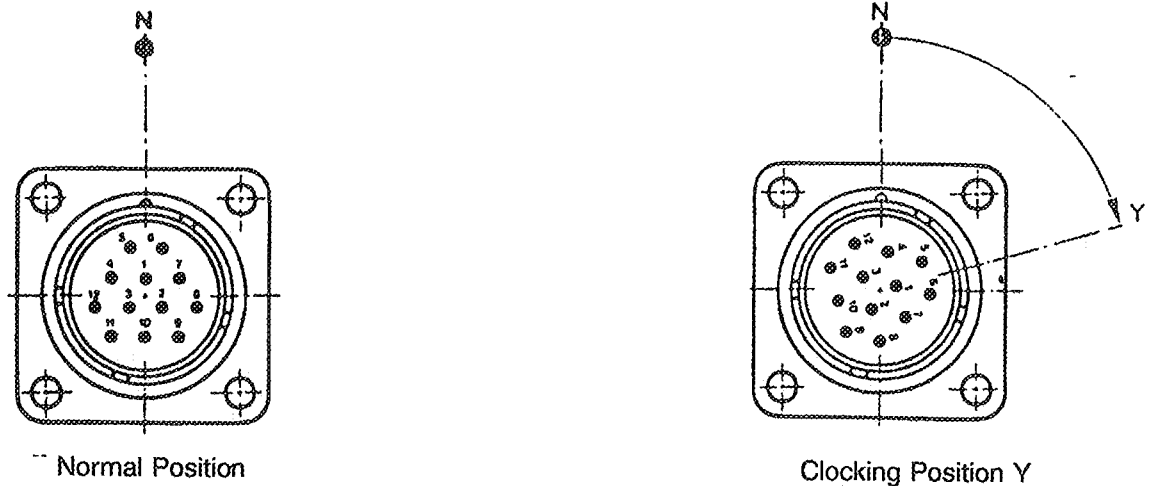
NOTES

1. Contact locations are in conformity with MIL-C-81703 specification sheets and shall not be checked during procurement.





FIGURE 2 - PHYSICAL DIMENSIONS (CONTINUED)

FIGURE 2(c) - INSERT CLOCKING POSITIONS



The normal position is achieved when the vertical axis of the insert (Figures 2(a) and 2(b)) is the same as the axis of the key in the shell (position N). Mating of two connectors with the same contact arrangement, standing side by side, can be made fool-proof by rotating one of the inserts within its shell. Rotation shall be clockwise for male inserts and anti-clockwise for female inserts. Determined rotations give clocking positions W, X, Y, B and C as specified below.

Contact Arrangement	Clocking Positions (°)				
	W	X	Y	B	C
3 - 0			75		
3 - 01					
7 - 0				150	
12 - 0	15	50	75	150	225
19 - 0			75	150	225
19 - 2	25	50	75	150	225
19 - 4			22.30	135	247.30
19 - 7			75	150	225
19 - 12	25	50	75	150	225
27 - 0	25	50	75	150	225
27 - 2	25	50		150	
27 - 8	25	50	75	150	225
27 - 13	25	50	75	150	225
37 - 0	25		75	150	225
37 - 924	105	13			
37 - 3	20	70			
37 - 13			75	150	225
37 - 19			75	150	225
37 - 27			75	150	225
37 - 30	25	50	75	150	225
37 - 961					
61 - 0	25		75	150	225
61 - 5	25	50	75	150	225
61 - 14					
61 - 21	25	50	75	150	225
61 - 42		67.30			
61 - 949	25	50	75	150	225

 	<p style="text-align: center;">ESA/SCC Detail Specification No. 3401/008</p>	<p style="text-align: right;">PAGE 14 ISSUE 5</p>
--	--	---

4. REQUIREMENTS

4.1 GENERAL

The complete requirements for procurement of the connectors specified herein shall be as stated in this specification and ESA/SCC Generic Specification No. 3401. Deviations from the Generic Specification, applicable to this specification only, are listed in Para. 4.2.

Deviations from the applicable Generic Specification and this Detail Specification, formally agreed with specific Manufacturers on the basis that the alternative requirements are equivalent to the ESA/SCC requirements and do not affect the components' reliability, are listed in the appendices attached to this specification.

4.2 DEVIATIONS FROM GENERIC SPECIFICATION

4.2.1 Deviations from Special In-process Controls

None.

4.2.2 Deviations from Final Production Tests (Chart II)

(a) Para. 9.5, Magnetism Level: Not applicable.

(b) For plugs with lanyard (Shell Type 78): Before External Visual Inspection, the lanyard shall be submitted to a distortion resistance test.

A pull force of 93DaN minimum shall be applied to the lanyard by means of a mandrel of 6.35mm diameter for 5 seconds. The force shall then be released, and the terminals shall be checked for distortion. Distortion shall not exceed 0.025mm in the direction of the application of the force.

4.2.3 Deviations from Burn-in and Electrical Measurements (Chart III)

Not applicable.

4.2.4 Deviations from Qualification Tests (Chart IV)

(a) Para. 9.9, Seal Test: Not applicable.

(b) Para. 9.11, Vibration: 20g, 10 - 2000 Hz.

(c) Para. 9.12, Shock: 100g, 11ms, half-sine wave.

(d) Para. 9.18, Endurance: The number of cycles for plug with grounding fingers shall be 250 only.

(e) Para. 9.24, Jackscrew Retention: Not applicable.

(f) For plugs with lanyard (Shell Type 78): At the end of Subgroup III, the lanyard shall be submitted to a tensile strength test. Prior to application of the load, the lanyard shall be marked at the point where it enters the swaging end of the terminal.

A force of 155DaN minimum shall be applied to the lanyard by means of a mandrel of 6.35mm diameter for 5 seconds. Breaking of the cable before reaching the specified load, any slippage of the cable in the fitting, or any sign of failure in the terminal shall constitute failure.

4.2.5 Deviations from Lot Acceptance Tests (Chart V)

(a) to (e) See Para. 4.2.4 above.

(f) The tensile strength test of the lanyard shall be performed as defined in Para. 4.2.4 on samples from the Environmental Subgroup.



4.3 MECHANICAL REQUIREMENTS

4.3.1 Dimension Check

The dimensions of the connectors specified herein shall be verified in accordance with the requirements set out in Para. 9.6 of ESA/SCC Generic Specification No. 3401 and shall conform to those shown in Figure 2 of this specification.

4.3.2 Weight

The maximum weight of the connectors specified herein, without contacts, shall be as specified in Table 1(a).

4.3.3 Contact Capability

As specified in ESA/SCC Detail Specification No. 3401/009 for contact size 08, 12, 16 and 20 and in ESA/SCC Details Specification No. 3401/012 for contact size 22.

4.3.4 Contact Retention (In Insert)

As specified in ESA/SCC Detail Specification No. 3401/009 for contact size 08, 12, 16 and 20 and in ESA/SCC Details Specification No. 3401/012 for contact size 22.

4.3.5 Mating and Unmating Forces

The forces applied for mating and unmating of the connectors shall conform to the values specified in Table 1(a). For plugs with lanyard, the unmating force shall be measured 3 times under the following conditions:-

- (a) Pull in the axial direction.
- (b) Pull $10 \pm 3^\circ$ left or right of the axial plane.
- (c) Pull $10 \pm 3^\circ$ above or below the axial plane.

4.3.6 Insert Retention (In Shell)

Connector inserts shall withstand a pressure of 5.27 kg/cm² without being dislodged from the shell.

4.3.7 Jackscrew Retention

Not applicable.

4.3.8 Contact Insertion and Withdrawal Forces

As specified in ESA/SCC Detail Specification No. 3401/009 for contact size 08, 12, 16 and 20 and in ESA/SCC Details Specification No. 3401/012 for contact size 22.

4.3.9 Engagement and Separation Forces

As specified in ESA/SCC Detail Specification No. 3401/009 for contact size 08, 12, 16 and 20 and in ESA/SCC Details Specification No. 3401/012 for contact size 22.

4.3.10 Oversize Pin Exclusion

As specified in ESA/SCC Detail Specification No. 3401/009 for contact size 08, 12, 16 and 20 and in ESA/SCC Details Specification No. 3401/012 for contact size 22.

4.3.11 Probe Damage

As specified in ESA/SCC Detail Specification No. 3401/009 for contact size 08, 12, 16 and 20 and in ESA/SCC Details Specification No. 3401/012 for contact size 22.

4.3.12 Solderability

As specified in ESA/SCC Detail Specification No. 3401/009 for contact size 08, 12, 16 and 20 and in ESA/SCC Details Specification No. 3401/012 for contact size 22.



4.4 MATERIALS AND FINISHES

The materials and finishes shall be as specified herein. Where a definite material is not specified, a material which will enable the connectors specified herein to meet the performance requirements of this specification shall be used. Acceptance or approval of any constituent material does not guarantee acceptance of the finished product.

4.4.1 Shells, Coupling Ring and Nut

Aluminium, nickel-plated. Where residual magnetism is of importance, a black anodise treatment can be ordered (see Para. 4.5.4.8).

4.4.2 Inserts

Bonded sandwich: Silicone/Phenolic/Silicone.

4.4.3 Contacts

As specified in ESA/SCC Detail Specification No. 3401/009 for contact size 08, 12, 16 and 20 and in ESA/SCC Details Specification No. 3401/012 for contact size 22.

4.4.4 Contact Retaining Clip

The retaining clip shall be made of beryllium copper.

4.4.5 Guiding and Locking Devices

Not applicable.

4.4.6 Magnetism Level

Not applicable.

4.5 MARKING

4.5.1 General

The marking of all components delivered to this specification shall be in accordance with the requirements of ESA/SCC Basic Specification No. 21700 and the following paragraphs. When the component is too small to accommodate all of the marking as specified, as much as space permits shall be marked and the marking information, in full, shall accompany the component in its primary package.

The information to be marked and the order of precedence, shall be as follows:-

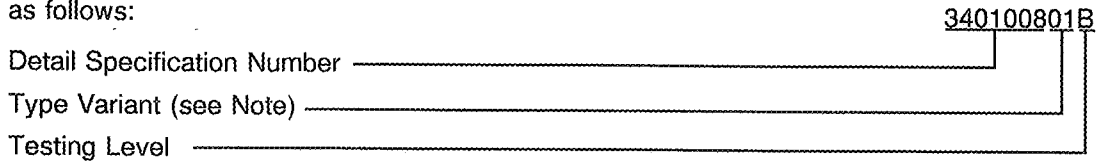
- (a) Contact Identification.
- (b) The SCC Component Number.
- (c) Characteristics.
- (d) Traceability Information.

4.5.2 Contact Identification

Contact identification shall be marked in accordance with Figures 2(a) and 2(b).

4.5.3 The SCC Component Number

Each component shall bear the SCC Component Number which shall be constituted and marked as follows:



N.B.

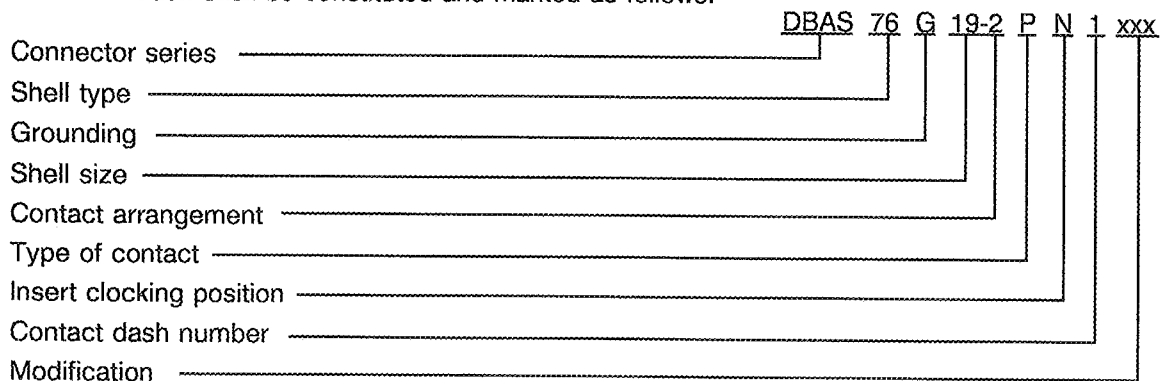
Marking of the Type Variant is mandatory. No further reference to type variants is made in this specification.

4.5.4 Characteristics

The characteristics to be marked in the following order of precedence are:-

- (a) Connector series.
- (b) Shell type.
- (c) Grounding.
- (d) Shell size.
- (e) Contact arrangement.
- (f) Type of contact.
- (g) Insert clocking position.
- (h) Contact dash number.
- (i) Modification.

The information shall be constituted and marked as follows:-



4.5.4.1 Connector Series

This connector series shall be designated by the letters DBAS.

4.5.4.2 Shell Type

The shell types shall be designated by the following numbers.

Code No.	Shell Type
70	Square flange receptacle
71	Cable connecting receptacle
74	Single hole mounting receptacle
76	Plug
78	Plug with lanyard
79	Rack and panel plug



4.5.4.3 Grounding

Grounding shall be indicated by the letter 'G'. When grounding is not required, the letter 'G' shall be omitted. Grounding is not applicable to receptacles, nor to black anodise finish.

4.5.4.4 Shell Sizes and Contact Arrangements

Shell sizes and contact arrangements are closely related to each other and shall be indicated by the following codes.

CODE Shell Size - Contact Arrangement	Number of Contacts
3 - 0	Numbers of contacts and contact sizes are as shown in Figures 2(a) and 2(b)
3 - 01	
7 - 0	
12 - 0	
19 - 0	
19 - 2	
19 - 4	
19 - 7	
19 - 12	
27 - 0	
27 - 2	
27 - 8	
27 - 13	
37 - 0	
37 - 3	
37 - 13	
37 - 19	
37 - 27	
37 - 30	
37 - 924	
37 - 961	
61 - 0	
61 - 5	
61 - 14	
61 - 21	
61 - 42	
61 - 949	

4.5.4.5 Types of Contact

The contact types shall be indicated by the following code letters.

Letter Code	Contact Type
P	Male
S	Female

4.5.4.6 Insert Clocking Position

Insert clocking positions are as shown in Figure 2(c) and shall be designated by the letter codes N, W, X, Y, B and C.

4.5.4.7 Contact Dash Numbers

The purpose of these numbers is to identify coaxial contacts which accept special cables. The following code numbers are applicable.

Contact Type	Cable Type	Code Number
Sizes 20 - 16 - 12	-	-
Standard coaxial	RG-174/U RG-178 B/U	-
	RG-179/U RG-187 B/U	-
	RG-188 A/U RG-196 A/U	-
Special coaxial	RG-180 B/U RG-195 B/U	1
Special coaxial	Special	9
Special coaxial	50 PPDTE	F1
Gauge 8 (Power)	Gauge 8	8
Size 22	-	-

4.5.4.8 Modification Codes

These high reliability connectors are ordered separately from the contacts and this is specified by code 090. This code shall never appear on the connector itself, but shall be used in paperwork only.

Modification codes shall be expressed in letters, numbers, or both. When there is no modification of the standard product, no code shall appear.

Plating codes: Black anodise treatment shall be identified by code 031.

Other codes: The cable lengths for shell type 78 are designated by the following modification codes.

Modification Code	Cable Length (mm)
A614	134.3 ± 2.1
B614	164.3 ± 2.1
B864	188.0 ± 2.5
C614	194.3 ± 2.1
E614	217.0 ± 2.1
L614	244.4 ± 2.1

4.5.5 Traceability Information

Each component shall be marked in respect of traceability information in accordance with the requirements of ESA/SCC Basic Specification No. 21700.

4.6 ELECTRICAL MEASUREMENTS

4.6.1 Electrical Measurements at Room Temperature

The parameters to be measured in respect of electrical characteristics are scheduled in Table 2. Unless otherwise specified, the measurements shall be performed at $T_{amb} = +22 \pm 3 \text{ }^\circ\text{C}$.

4.6.2 Electrical Measurements at High and Low Temperatures (Table 3)

Not applicable.

4.6.3 Circuits for Electrical Measurements (Figure 4)

Not applicable.

4.7 BURN-IN AND ELECTRICAL MEASUREMENTS (TABLES 4 AND 5)

Not applicable.

TABLE 2 - ELECTRICAL MEASUREMENTS AT ROOM TEMPERATURE

No.	CHARACTERISTICS	SYMBOL	SPEC. AND TEST METHOD	TEST CONDITIONS	LIMITS		UNIT
					MIN.	MAX.	
1	Insulation Resistance	Ri	ESA/SCC No. 3401 Para. 9.1.1.1	Para. 9.1.1.1	10 000	-	MΩ
2	Voltage Proof Leakage Current	I_L	ESA/SCC No. 3401 Para. 9.1.1.2	1500V	-	2.0	mA
3	Mated Shell Conductivity (Voltage Drop) (1)	Vd	ESA/SCC No. 3401 Para. 9.1.1.4	Para. 9.1.1.4	-	1.0	mV

NOTES

1. Applicable to mated connectors with grounding option.

TABLES 3, 4 AND 5

Not applicable.



- 4.8 ENVIRONMENTAL AND ENDURANCE TESTS (CHARTS IV AND V OF ESA/SCC GENERIC SPECIFICATION NO. 3401)
- 4.8.1 Measurements and Inspections on Completion of Environmental Tests
The parameters to be measured and inspections to be performed on completion of environmental testing shall be those specified in Table 6. Unless otherwise stated, the measurements shall be performed at $T_{amb} = +22 \pm 3$ °C.
- 4.8.2 Measurements and Inspections at Intermediate Points during Endurance Tests
Not applicable.
- 4.8.3 Measurements and Inspections on Completion of Endurance Tests
The parameters to be measured and inspections to be performed on completion of endurance tests shall be those specified in Table 6. Unless otherwise stated, the measurements shall be performed at $T_{amb} = +22 \pm 3$ °C.
- 4.8.4 Conditions for Operating Life Tests (Part of Endurance Testing)
Not applicable.
- 4.8.5 Electrical Circuit for Operating Life Tests (Figure 5)
Not applicable.
- 4.8.6 Conditions for High Temperature Storage Test (Part of Endurance Testing)
The requirements for the high temperature storage test are specified in Section 9 of ESA/SCC Generic Specification No. 3401. The conditions for high temperature storage testing shall be the maximum storage temperature specified in Table 1(b) of this specification.



TABLE 6 - MEASUREMENTS AND INSPECTIONS ON COMPLETION OF ENVIRONMENTAL AND ENDURANCE TESTING

NO.	ESA/SCC GENERIC NO. 3401		MEASUREMENTS AND INSPECTIONS			LIMITS		UNIT
	ENVIRONMENTAL AND ENDURANCE TESTS (1)	TEST METHOD AND CONDITIONS	IDENTIFICATION	CONDITIONS	SYMBOL	MIN	MAX	
01	Seal Test	Para. 9.9	ESA/SCC 3401 Para. 9.9	-	-	Not applicable		
02	Wiring	Para. 9.10	ESA/SCC 3401/009/012	-	-	-	-	
03	Vibration	Para. 9.11 & Para. 4.2.4 of this spec.	Initial Measurements Coupling Screw(s) Unlocking Torque Final Measurements Full Engagement Coupling Screw(s) Unlocking Torque Drift Visual Examination	- - - - -	- - Δ -	Not applicable - -	- -	%
04	Shock or Bump	Para. 9.12 & Para. 4.2.4 of this spec.	Full Engagement Visual Examination	- -	- -	- -	- -	
05	Climatic Sequence	Para. 9.13	Dry Heat Insulation Resistance Low Air Pressure Voltage Proof Leakage Curr. Damp Heat Insulation Resistance Final Measurements External Visual Inspection Insulation Resistance Voltage Proof Leakage Curr.	Table 2 Item 1 Figure 1 Immediately after test Table 2 Item 1 After 1-24 hrs Recovery ESA/SCC 3401 Para. 9.7 Table 2 Item 1 Table 2 Item 2	Ri I _L Ri - Ri I _L	1 000 Table 2 Item 2 100 ESA/SCC 3401 Para. 9.7 Table 2 Item 1 Table 2 Item 2	- -	M Ω M Ω
06	Plating Thickness	Para. 9.14	Thickness	-	-	ESA/SCC 3401/009/012		
07	Joint Strength	Para. 9.15	ESA/SCC 3401 Para. 9.15	-	-	ESA/SCC 3401 Para. 9.15		
08	Rapid Change of Temperature	Para. 9.16	Final Measurements Visual Examination Insulation Resistance Voltage Proof Leakage Curr.	- Table 2 Item 1 Table 2 Item 2	- Ri I _L	- Table 2 Item 1 Table 2 Item 2	- -	
09	Contact Retention (In Insert)	Para. 9.17 & Para. 4.3.4 of this spec.	Contact Displacement	-	-	ESA/SCC 3401 Para. 9.17		
10	Endurance	Para. 9.18	Initial Measurements Mating/Unmating Forces Low Level Contact Resist Mated Shell Conductivity Final Measurements Visual Examination Mating/Unmating Forces Low Level Contact Resistance Drift Mated Shell Conductivity Insulation Resistance Voltage Proof Leakage Curr.	- ESA/SCC 3401/009/012 Table 2 Item 3 ESA/SCC 3401/009/012 Table 2 Item 3 Table 2 Item 1 Table 2 Item 2	F Rcl Vd F Δ Rcl Vd Ri I _L	Para. 4.3.5 of this spec Record Values Table 2 Item 3 Para. 4.3.5 of this spec ESA/SCC 3401/009/012 Table 2 Item 3 Table 2 Item 1 Table 2 Item 2		

NOTES 1. The tests in this table refer to either Chart IV or V and shall be used as applicable.



TABLE 6 - MEASUREMENTS AND INSPECTIONS ON COMPLETION OF ENVIRONMENTAL AND ENDURANCE TESTING (CONT'D)

NO.	ESA/SCC GENERIC NO. 3401		MEASUREMENTS AND INSPECTIONS		SYMBOL	LIMITS		UNIT
	ENVIRONMENTAL AND ENDURANCE TESTS (1)	TEST METHOD AND CONDITIONS	IDENTIFICATION	CONDITIONS		MIN	MAX	
11	Permanence of Marking	Para. 9.19	As applicable	-	-	-	-	
12	Mating/Unmating Forces	Para. 9.20	Force	-	F	Para. 4.3.5 of this spec.		
13	High Temperature Storage	Para. 9.21	Initial Measurements Low Level Contact Resis. Mated Shell Conductivity Final Measurements Visual Examination Mating/Unmating Forces Low Level Contact Resistance Drift Rated Current Contact Resis. Mated Shell Conductivity Insulation Resistance Voltage Proof Leakage Curr. Contact Retention (In Insert)	ESA/SCC 3401/009 Table 2 Item 3 - - ESA/SCC 3401/009 ESA/SCC 3401/009 Table 2 Item 3 Table 2 Item 1 Table 2 Item 2 Para. 4.3.4 of this spec.	Rcl Vd - F ΔRcl Rcr Vd Ri I _L -	Record Values Table 2 Item 3 - - Para. 4.3.5 of this spec. ESA/SCC 3401/009 ESA/SCC 3401/009 Table 2 Item 3 Table 2 Item 1 Table 2 Item 2 ESA/SCC 3401 Para. 9.17		
14	Corrosion	Para. 9.22	Visual Examination	-	-	-	-	
15	Insert Retention (In Shell)	Para. 9.23 & Para. 4.3.6 of this spec.	Visual Examination	-	-	Para. 4.3.6		
16	Jackscrew Retention	Para. 9.24 & Para. 4.3.7 of this spec.	Visual Examination	-	-	Not applicable		
17	High Temperature Measurements	Para. 9.25	Insulation Resistance	Table 2 Item 1	Ri	500	-	MΩ
18	Overload Test	Para. 9.26	Internal Temperature Rated Current Contact Resis. Mated Shell Conductivity Insulation Resistance Voltage Proof Leakage Curr.	ESA/SCC 3401/009 Table 2 Item 3 Table 2 Item 1 Table 2 Item 2	T Rcr Vd Ri I _L	-	+100	°C
19	Maintenance Ageing	Para. 9.27	Visual Examination Contact Retention (In Insert) Contact Insertion & Withdrawal Forces	- Para. 4.3.4 of this spec. Para. 4.3.8 of this spec	-	-	-	ESA/SCC 3401 Para. 9.17 Para. 4.3.8
20	Engage/Separation Forces	Para. 9.28 & Para. 4.3.9 of this spec	Force	-	F	Para. 4.3.9		

NOTES 1. The tests in this table refer to either Chart IV or V and shall be used as applicable.

**SCC**ESA/SCC Detail Specification
No. 3401/008

PAGE 24

ISSUE 5

TABLE 6 - MEASUREMENTS AND INSPECTIONS ON COMPLETION OF ENVIRONMENTAL AND ENDURANCE TESTING (CONT'D)

NO.	ESA/SCC GENERIC NO. 3401		MEASUREMENTS AND INSPECTIONS			LIMITS		UNIT
	ENVIRONMENTAL AND ENDURANCE TESTS (1)	TEST METHOD AND CONDITIONS	IDENTIFICATION	CONDITIONS	SYMBOL	MIN	MAX	
21	Oversize Pin Exclusion	Para. 9.29 & Para. 4.3.10 of this spec	-	-	-	ESA/SCC 3401 Para. 9.29		
22	Probe Damage	Para. 9.30 & Para. 4.3.11 of this spec	Contact Separation Force	Para. 4.3.9 of this spec	F	Para. 4.3.9		
23	Solderability	Para. 9.31 & Para. 4.3.12 of this spec.	-	-	-	Para. 4.3.12		
24	Tensile Strength (Lanyard)	Para. 4.2.4 of this spec.	Visual Examination	Para. 4.2.4	-	Para. 4.2.4		

NOTES

1. The tests in this table refer to either Chart IV or V and shall be used as applicable.