



europaean space agency  
agence spatiale europeenne

Pages 1 to 15



**CONTACTS, ELECTRICAL, CRIMP**

**FOR 3401/011 CONNECTORS**

**ESA/SCC Detail Specification No. 3401/012**

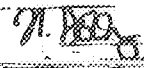
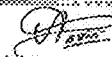

**space components  
coordination group**

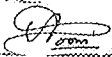
Issue/Rev.	Date	Approved by	
		SCCG Chairman	ESA Director General or his Deputy
Issue 3	August 2001		
Revision 'A'	March 2002		

**SCC**ESA/SCC Detail Specification  
No. 3401/012

Rev. 'A'

PAGE 2

ISSUE 3

**DOCUMENTATION CHANGE NOTICE**

Rev. Letter	Rev. Date	Reference	CHANGE Item	Approved DCR No.
		This issue supersedes Issue 2 and incorporates all modifications defined in Issue 2, Revision 'A' and the changes agreed in the following DCR's:  Specification entirely rewritten to align with ESA/SCC Detail Specification No. 3401/005		21191
'A'	Mar. '02	P1. Cover page P2. DCN P6. Table 1(a)	: : : "Mating End" and "Crimp Barrel" colours changed	None None 221654

**SCC**

ESA/SCC Detail Specification

No. 3401/012

PAGE 3

ISSUE 3

**TABLE OF CONTENTS**

	<u>Page</u>
<b>1. <u>GENERAL</u></b>	<b>5</b>
1.1 Scope	5
1.2 Type Variants	5
1.3 Maximum Ratings	5
1.4 Parameter Derating Information	5
1.5 Physical Dimensions	5
<b>2. <u>APPLICABLE DOCUMENTS</u></b>	<b>9</b>
<b>3. <u>TERMS, DEFINITIONS, ABBREVIATIONS, SYMBOLS AND UNITS</u></b>	<b>9</b>
<b>4. <u>REQUIREMENTS</u></b>	<b>9</b>
4.1 General	9
4.2 Deviations from Generic Specification	9
4.2.1 Deviations from Special In-process Controls	9
4.2.2 Deviations from Final Production Tests	9
4.2.3 Deviations from Burn-in and Electrical Measurements	9
4.2.4 Deviations from Qualification Tests	9
4.2.5 Deviations from Lot Acceptance Tests	9
4.3 Mechanical Requirements	10
4.3.1 Dimension Check	10
4.3.2 Weight	10
4.3.3 Contact Capability	10
4.3.4 Contact Retention	10
4.3.5 Mating and Unmating Forces	10
4.3.6 Insert Retention	10
4.3.7 Jackscrew Retention	10
4.3.8 Contact Insertion and Withdrawal Forces	10
4.3.9 Engagement and Separation Forces	10
4.3.10 Oversize Pin Exclusion	10
4.3.11 Probe Damage	10
4.3.12 Solderability	10
4.4 Materials and Finishes	11
4.4.1 Shells	11
4.4.2 Inserts	11
4.4.3 Contacts	11
4.4.4 Contact Retaining Clip	11
4.4.5 Guiding and Locking Devices	11
4.4.6 Magnetism Level	11
4.5 Marking	11
4.5.1 General	11
4.5.2 The SCC Component Number	11
4.5.3 Traceability Information	11
4.6 Electrical Measurements	12
4.6.1 Electrical Measurements at Room Temperature	12
4.6.2 Electrical Measurements at High and Low Temperatures	12
4.6.3 Circuits for Electrical Measurements	12
4.7 Burn-in and Electrical Measurements	12
4.8 Environmental and Endurance Tests	12
4.8.1 Measurements and Inspections on Completion of Environmental Tests	12
4.8.2 Measurements and Inspections at Intermediate Points during Endurance Tests	12
4.8.3 Measurements and Inspections on Completion of Endurance Tests	12
4.8.4 Conditions for Operating Life Test	12



4.8.5	Electrical Circuits for Operating Life Test	<u>Page</u> 12
4.8.6	Conditions for High Temperature Storage Test	12

**TABLES**



1(a)	Type Variants	6
1(b)	Maximum Ratings	7
2	Electrical Measurements at Room Temperature	13
3	Not applicable	N/A
4	Not applicable	N/A
5	Not applicable	N/A
6	Measurements and Inspections on Completion of Environmental and Endurance Tests	14

**FIGURES**

1	Parameter Derating Information	7
2	Physical Dimensions	
	- Variants 01 and 03 - Male Contacts	8
	- Variants 02 and 04 - Female Contacts	8

**APPENDICES (Applicable to specific Manufacturers only)**

None.

		<p style="text-align: center;">ESA/SCC Detail Specification No. 3401/012</p>		<p>PAGE 5 ISSUE 3</p>
--	---	--	--	---------------------------

1. GENERAL

1.1 SCOPE

This specification details the ratings, physical and electrical characteristics, test and inspection data for Contacts, Electrical, Crimp, Gauge 22, for 3401/011 Connectors.

These contacts shall be packed separately from the connectors and may be procured either with the connectors or separately.

This specification shall be read in conjunction with:

- ESA/SCC Generic Specification No. 3401, Connectors, Electrical, Non-Filtered, Circular and Rectangular,
- ESA/SCC Detail Specification No. 3401/011, Connectors, Electrical, Rectangular, Central Jackscrew Coupling, Removable Crimp Contacts, Based on Type U.R,

the requirements of which are supplemented herein.

1.2 TYPE VARIANTS

The different sizes of contacts specified herein, which are also covered by this specification are scheduled in Table 1(a).

1.3 MAXIMUM RATINGS

The maximum ratings, which shall not be exceeded at any time during use or storage, applicable to the contacts specified herein, are scheduled in Table 1(b).

1.4 PARAMETER DERATING INFORMATION (FIGURE 1)

Not applicable.

1.5 PHYSICAL DIMENSIONS

The physical dimensions of the contacts specified herein are shown in Figure 2.



ESA/SCC Detail Specification

No. 3401/012

PAGE 6

ISSUE 3

**TABLE 1(a) - TYPE VARIANTS**

VAR-VARIANT	TYPE	MATING END SIZE COLOUR	CRIMP BARREL SIZE COLOUR	RATED CURRENT	ACCEPT WIRE	MAX WEIGHT	ENGAGEMENT & SEPARATION		TEST PINS			CONTACT CAPABILITY			CONTACT INSERT WITHDR FORCES MAX	PROBE DAMAGE		OVERSIZE PIN EXCL.	
							ENGAG. FORCES N (1)	SEPAR. FORCES N (1)	min.	max.	Pick-up (2) g	Drop (3) g	MO-MENT	PROBE DIA mm		FORCE MAX	TEST PIN DIA mm	min	max
01	Male	22 Green	22 Green	5.0	22	0.78	-	-	-	-	-	-	-	-	-	-	-	-	-
02	Female	22 Green	24 Green	5.0	24	0.075	3.33	2.22	0.710	0.747	-	230	18.50	0.710	0.713	3.33	0.837	0.841	
03	Male	22 Green	26 White	2.0	26	0.078	-	-	-	-	-	-	18.50	-	-	-	-	-	
04	Female	22 Green	30 White	2.0	30	0.075	3.33	2.22	0.710	0.747	-	230	18.50	0.710	0.713	3.33	0.837	0.841	

**NOTES**

- 1st line, maximum values with maximum diameter test pin;  
2nd line, minimum values with minimum diameter test pin.
- With minimum diameter test pin and minimum insertion depth of 3.0mm.
- With maximum diameter test pin and minimum insertion depth of 3.0mm.

**SCC**ESA/SCC Detail Specification  
No. 3401/012

PAGE 7

ISSUE 3

**TABLE 1(b) - MAXIMUM RATINGS**

No.	CHARACTERISTICS	SYMBOL	MAXIMUM RATING		UNIT
			MIN.	MAX.	
1	Rated Current	$I_{CR}$	-	See Table 1(a)	A
2	Operating Temperature Range	$T_{op}$	-55	+125	°C
3	Storage Temperature Range	$T_{stg}$	-65	+125	°C

**FIGURE 1 - PARAMETER DERATING INFORMATION**

Not applicable.



**FIGURE 2 - PHYSICAL DIMENSIONS (CONTINUED)**

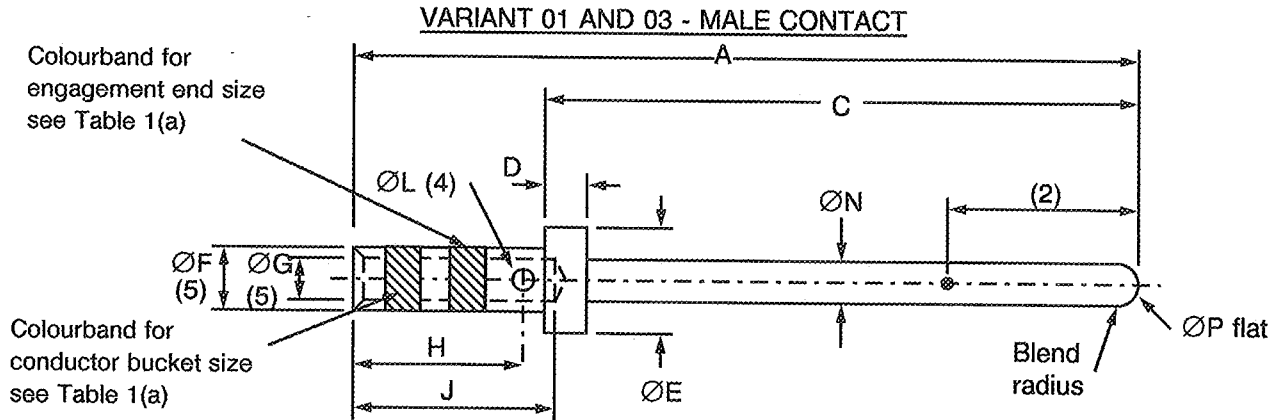

		Var.01	Var. 03									
	<u>A</u>	<u>C</u>	<u>D</u>	<u>ØE</u>	<u>ØF</u>	<u>ØG</u>	<u>ØG</u>	H	J	<u>ØL</u>	<u>ØN</u>	<u>ØP</u>
Min.	-	7.45	0.85	1.45	1.15	0.89	0.79	2.7	3.36	0.37	0.71	-
Max.	12.00	7.56	0.90	1.50	1.20	0.94	0.84	2.9	3.40	0.63	0.74	0.25

**NOTES**

1. All dimensions are in millimetres.
2. Measurement point for plating thickness:  $4.0 \pm 1.0$ .
3. Underlined dimensions, in table, are critical to ensure intermateability and interchangeability.
4. Inspection hole may be  $\varnothing L$  square and shall only penetrate one wall of the crimp barrel.
5.  $\varnothing F$  and  $\varnothing G$  to be concentric within 0.04.

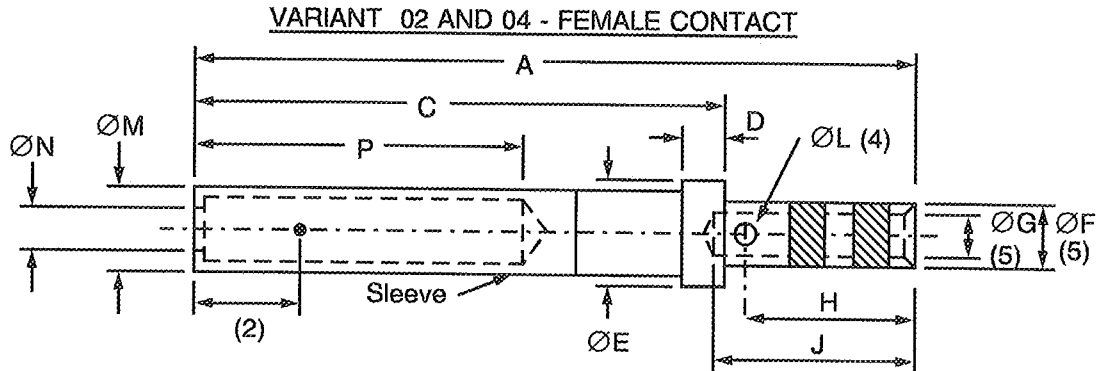

		Var. 02	Var. 04										
	<u>A</u>	<u>C</u>	<u>D</u>	<u>ØE</u>	<u>ØF</u>	<u>ØG</u>	<u>ØG</u>	H	J	<u>ØL</u>	<u>ØM</u>	<u>ØN</u>	<u>P</u>
Min.	-	-	0.86	1.45	1.15	0.89	0.79	2.7	3.36	0.37	-	0.75	4.56
Max.	11.64	7.20	0.91	1.50	1.20	0.94	0.84	2.9	3.40	0.63	1.31	-	5.00

**NOTES**

1. All dimensions are in millimetres.
2. Measurement point for plating thickness:  $2.0 \pm 1.0$ .
3. Underlined dimensions, in table, are critical to ensure intermateability and interchangeability.
4. Inspection hole may be  $\varnothing L$  square and shall only penetrate one wall of the crimp barrel.
5.  $\varnothing F$  and  $\varnothing G$  to be concentric within 0.04.



**2. APPLICABLE DOCUMENTS**

The following documents form part of this specification and shall be read in conjunction with it:-

- (a) ESA/SCC Generic Specification No. 3401, Connectors, Electrical, Non-Filtered, Circular and Rectangular.
- (b) ESA/SCC Detail Specification No. 3401/011, Connectors, Electrical, Rectangular, Central Jackscrew Coupling, Removable Crimp Contacts, Based on Type U.R.
- (c) MIL-G-45204, Gold Plating, Electro-deposited.
- (d) MIL-C-14450, Copper Plating, Electro-deposited.

**3. TERMS, DEFINITIONS, ABBREVIATIONS, SYMBOLS AND UNITS**

For the purpose of this specification, the terms, definitions, abbreviations, symbols and units specified in ESA/SCC Basic Specification No. 21300 shall apply.

**4. REQUIREMENTS****4.1 GENERAL**

The complete requirements for procurement of the contacts specified herein are stated in this specification and ESA/SCC Generic Specification No. 3401. Deviations from the Generic Specification, applicable to this Detail Specification only, are listed in Para. 4.2.

Deviations from the applicable Generic Specification and this Detail Specification, formally agreed with specific Manufacturers on the basis that the alternative requirements are equivalent to the ESA/SCC requirements and do not affect the components' reliability, are listed in the appendices attached to this specification.

**4.2 DEVIATIONS FROM GENERIC SPECIFICATION****4.2.1 Deviations from Special In-process Controls**

None.

**4.2.2 Deviations from Final Production Tests (Chart II)**

None.

**4.2.3 Deviations from Burn-in and Electrical Measurements (Chart III)**

Not applicable.

**4.2.4 Deviations from Qualification Tests (Chart IV)**

- (a) Para. 9.31, Solderability: Not applicable.

**4.2.5 Deviations from Lot Acceptance Tests (Chart V)**

- (a) Para. 9.31, Solderability: Not applicable.



#### 4.3 MECHANICAL REQUIREMENTS

##### 4.3.1 Dimension Check

The dimensions of the contacts specified herein shall be verified in accordance with the requirements set out in Para. 9.6 of ESA/SCC Generic Specification No. 3401 and shall conform to those shown in Figure 2 of this specification. Only the underlined dimensions shall be checked during procurement.

##### 4.3.2 Weight

The maximum weight of the contacts specified herein shall be as specified in Table 1(a).

##### 4.3.3 Contact Capability

For the purpose of this test, the pick-up and drop weights shall be as specified in Table 1(a).

##### 4.3.4 Contact Retention (in insert)

The contact retention force shall be as specified in Table 1(a).

##### 4.3.5 Mating and Unmating Forces

As specified in ESA/SCC Detail Specification No. 3401/011.

##### 4.3.6 Insert Retention (In Shell)

As specified in ESA/SCC Detail Specification No. 3401/011.

##### 4.3.7 Jackscrew Retention

As specified in ESA/SCC Detail Specification No. 3401/011.

##### 4.3.8 Contact Insertion and Withdrawal Forces

The contact insertion and withdrawal forces shall be as specified in Table 1(a).

##### 4.3.9 Engagement and Separation Forces

The diameter of the test pin and the engagement and separation forces of the female contacts shall be as specified in Table 1(a).

##### 4.3.10 Oversize Pin Exclusion

The diameter of the test pin and the force applied to it shall be as specified in Table 1(a).

##### 4.3.11 Probe Damage

The probe diameter and the moment at the end of the probe shall be as specified in Table 1(a).

##### 4.3.12 Solderability

Not applicable.



4.4 MATERIALS AND FINISHES

The materials and finishes shall be as specified herein. Where a definite material is not specified, a material which will enable the connectors specified herein to meet the performance requirements of this specification shall be used. Acceptance or approval of any constituent material does not guarantee acceptance of the finished product.

4.4.1 Shells

As specified in ESA/SCC Detail Specification No. 3401/011.

4.4.2 Inserts

As specified in ESA/SCC Detail Specification No. 3401/011.

4.4.3 Contacts

The contact body shall be made of copper alloy with an underplate of 1.0µm minimum of copper to MIL-C-14450, gold plated with 2.5µm of gold, Type 2 Grade C of MIL-G-45204.

4.4.4 Contact Retaining Clip

As specified in ESA/SCC Detail Specification No. 3401/011.

4.4.5 Guiding and Locking Devices

As specified in ESA/SCC Detail Specification No. 3401/011.

4.4.6 Magnetism Level

As specified in ESA/SCC Detail Specification No. 3401/011.

4.5 MARKING

4.5.1 General

The marking of all components delivered to this specification shall be in accordance with the requirements of ESA/SCC Basic Specification No. 21700 and the following subparagraphs.

These components being too small to accommodate the marking as specified hereafter, the full marking information shall accompany each lot of components in its primary package. Such marking shall comprise:-

- (a) The SCC Component Number.
- (b) Traceability information.

4.5.2 The SCC Component Number

The SCC component number shall be constituted and marked as follows:-

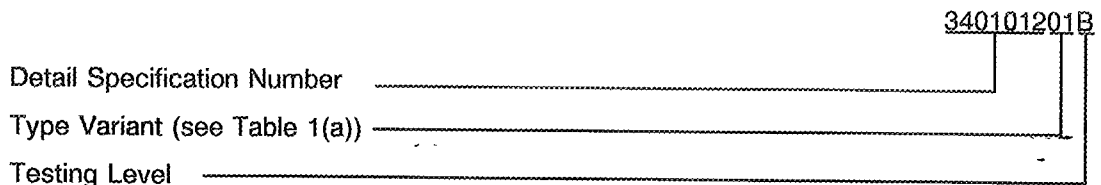

4.5.3 Traceability Information

Traceability information shall be marked in accordance with ESA/SCC Basic Specification No. 21700.



#### 4.6 ELECTRICAL MEASUREMENTS

##### 4.6.1 Electrical Measurements at Room Temperature

The parameters to be measured in respect of electrical characteristics are scheduled in Table 2. Unless otherwise specified these measurements shall be performed at  $T_{amb} = +22 \pm 3$  °C.

##### 4.6.2 Electrical Measurements at High and Low Temperatures (Table 3)

Not applicable.

##### 4.6.3 Circuit for Electrical Measurements (Figure 4)

Not applicable.

#### 4.7 BURN-IN AND ELECTRICAL MEASUREMENTS (TABLES 4 AND 5)

Not applicable.

#### 4.8 ENVIRONMENTAL AND ENDURANCE TESTS

##### 4.8.1 Measurements and Inspections on Completion of Environmental Tests

The parameters to be measured and inspections to be performed on completion of environmental testing are scheduled in Table 6. Unless otherwise specified, these measurements shall be performed at  $T_{amb} = +22 \pm 3$  °C.

##### 4.8.2 Measurements and Inspections at Intermediate Points during Endurance Tests

Not applicable.

##### 4.8.3 Measurements and Inspections on Completion of Endurance Tests

The parameters to be measured and inspections to be performed on completion of endurance tests shall be those specified in Table 6. Unless otherwise specified, these measurements shall be performed at  $T_{amb} = +22 \pm 3$  °C.

##### 4.8.4 Conditions for Operating Life Test (Part of Endurance Testing)

Not applicable.

##### 4.8.5 Electrical Circuits for Operating Life Test

Not applicable.

##### 4.8.6 Conditions for High Temperature Storage Test (Part of Endurance Testing)

The requirements for the high temperature storage test are specified in Section 9 of ESA/SCC Generic Specification No. 3401. The conditions for high temperature storage testing shall be the maximum storage temperature specified in Table 1(b) of this specification.



**TABLE 2 - ELECTRICAL MEASUREMENTS AT ROOM TEMPERATURE**

No.	CHARACTERISTICS	SYMBOL	SPEC. AND/OR TEST METHOD	TEST CONDITION	VARIANTS	LIMITS		UNIT
						MIN.	MAX.	
1	Contact Resistance (Low Level Current)	Rcl	ESA/SCC No. 3401 Para 9.1.1.3	Para 9.1.1.3	All	-	6.0	mΩ
2	Contact Resistance (Rated Current)	Rcr	ESA/SCC No. 3401 Para 9.1.1.3	Para 9.1.1.3  5.0A	All	- - -	5.0 5.0 5.0	mΩ mΩ mΩ

**TABLES 3, 4 AND 5**

Not applicable.



**SCC**

ESA/SCC Detail Specification

No. 3401/012

PAGE 14

ISSUE 3

**TABLE 6 - MEASUREMENTS AND INSPECTIONS ON COMPLETION OF ENVIRONMENTAL AND ENDURANCE TESTS**

NO.	ESA/SCC GENERIC NO. 3401		MEASUREMENTS AND INSPECTIONS		SYMBOL	LIMITS		UNIT
	ENVIRONMENTAL AND ENDURANCE TESTS (1)	TEST METHOD AND CONDITIONS	IDENTIFICATION	CONDITIONS		MIN	MAX	
01	Wiring	Para. 9.10 & Table 1(a) of this spec.	Low Level Contact Resistance	Table 2 Item 1	Rcl	Table 2 Item 1		
02	Vibration	Para. 9.11	ESA/SCC 3401/011					
03	Shock or Bump	Para. 9.12	ESA/SCC 3401/011					
04	Climatic Sequence	Para. 9.13	ESA/SCC 3401/011					
05	Seal Test	Para. 9.9	ESA/SCC 3401/011					
06	Plating Thickness	Para. 9.14	Thickness	-	-	Para. 4.4.3 of this spec		
07	Joint Strength	Para. 9.15	ESA/SCC 3401 Para 9.15					
08	Rapid Change of Temperature	Para. 9.16	ESA/SCC 3401/011					
09	Contact Retention (in insert)	Para. 9.17 & Para. 4.3.4 of this spec.	Contact Displacement		-	ESA/SCC 3401 Para. 9.17		
10	Endurance	Para. 9.18	Initial Low Level Contact Resist	Table 2 Item 1	Rcl	Record Values		mΩ
			Final Low Level Contact Resistance Drift	Table 2 Item 1	ΔRcl	-	3.0	
11	Permanence of Marking	Para. 9.19	As applicable					
12	Mating/Unmating Forces	Para. 9.20	ESA/SCC 3401/011					
13	High Temperature Storage	Para. 9.21	Initial Low Level Contact Resist	Table 2 Item 1	Rcl	Record Values		mΩ
			Final Low Level Contact Resistance Drift	Table 2 Item 1	ΔRcl	-	3.0	
			Rated Current Contact Resistance	Table 2 Item 2	Rcr	Table 2 Item 2		
	Contact Retention (in insert)	Para. 4.3.4 of this spec.			-	ESA/SCC 3401 Para. 9.17		
14	Corrosion	Para. 9.22	Visual Examination					

**NOTES**

1. The tests in this table refer to either Chart IV or V and shall be used as applicable.



**TABLE 6 - MEASUREMENTS AND INSPECTIONS ON COMPLETION OF ENVIRONMENTAL AND ENDURANCE TESTS (CONTINUED)**

NO.	ESA/SCC GENERIC NO. 3401		MEASUREMENTS AND INSPECTIONS			LIMITS		UNIT
	ENVIRONMENTAL AND ENDURANCE TESTS (1)	TEST METHOD AND CONDITIONS	IDENTIFICATION	CONDITIONS	SYMBOL	MIN	MAX	
15	Insert Retention (in shell)	Para. 9.23 & Para. 4.3.6 of this spec.	ESA/SCC 3401/011					
16	Jackscrew Retention	Para. 9.24 & Para. 4.3.7 of this spec.	ESA/SCC 3401/011					
17	High Temperature Measurements	Para. 9.25	ESA/SCC 3401/011					
18	Overload Test	Para. 9.26	Rated Current Contact Resistance	Table 2 Item 2	Rcr	Table 2 Item 2		
19	Maintenance Aging	Para. 9.27	Visual Examination Contact Retention  Contact Insertion & Withdrawal Forces	- Para. 4.3.4 of this spec. Para. 4.3.8 of this spec.	- - -	ESA/SCC 3401 Para. 9.17 Para. 4.3.8		
20	Engage/Separation Forces	Para. 9.28 & Para. 4.3.9 of this spec.	Force		-	Para. 4.3.9		
21	Oversize Pin Exclusion	Para. 9.29 & Para. 4.3.10 of this spec.			-	ESA/SCC 3401 Para. 9.29		
22	Probe Damage	Para. 9.30 & Para. 4.3.11 of this spec.	Contact Separation Force	Para. 4.3.9 of this spec.	-	Para. 4.3.9		
23	Solderability	Para. 9.31 & Para. 4.3.12 of this spec.	Not applicable					

**NOTES**

1. The tests in this table refer to either Chart IV or V and shall be used as applicable.