



europaean space agency
agence spatiale européenne

Pages 1 to 28

**CONTACTS, ELECTRICAL, CRIMP, WIRE-WRAP,
SOLDER AND SAVER
FOR 3401/016 CONNECTORS
ESA/SCC Detail Specification No. 3401/017**



**space components
coordination group**


Issue/Rev.	Date	Approved by	
		SCCG Chairman	ESA Director General or his Deputy
Issue 3	January 1997	<i>Sam Mills</i>	<i>[Signature]</i>
Revision 'A'	April 1998	<i>Sam Mills</i>	<i>[Signature]</i>

DOCUMENTATION CHANGE NOTICE

Rev. Letter	Rev. Date	Reference	CHANGE Item	Approved DCR No.
		This Issue supersedes Issue 2 and incorporates all modifications defined in Revisions 'A', 'B' and 'C' to Issue 2 and the changes agreed in the following DCR's:-		
		Cover page	: Title amended	221379
		DCN		None
		Para. 1.1	: Text of first sentence expanded	221379
			: Reference specification Titles amended	221379
		Para. 1.2	: Text amended	221379
		Para. 1.4	: Text deleted and "Not applicable" added	221379
		Para. 2	: Items (a) and (b), Titles amended	221379
			: Items (c) to (h) deleted	221379
		Table 1(a)	: Table completely revised	221379
		Table 1(b)	: No. 1, Characteristic and Rating amended and Remark deleted	221379
			: No. 4, added	221379
			: Note 1 added	221379
		Figure 1	: Figure deleted and "Not applicable" added	221379
		Figure 2	: Variants 01, 02, 03, 05, 06, 07, 08, 10, 11, 12, 13, 14, 16, 17, 18, 19, 21, 22, 64, 65, 66, 67, 68, 69 and 70 added	221379
			: For Variants 04 and 15, drawings and tables amended and Notes added	221379
		Para. 4.2.2	: Deviation added	221379
		Para. 4.2.4	: Deviations added	221379
		Para. 4.2.5	: Deviations added	221379
		Para. 4.3.1	: Sentence added	23845
		Paras. 4.3.3 to 4.3.12	: Paragraphs retitled, reordered and rewritten	221379
		Paras. 4.4.1 to 4.4.6	: Paragraphs retitled, reordered and rewritten	221379
		Para. 4.5.2	: Item (c) deleted	221379
		Para. 4.7	: Title amended	221379
		Para. 4.8.1	: Text amended	221379
		Para. 4.8.2	: Text deleted and "Not applicable" added	221379
		Para. 4.8.3	: Text amended	221379
		Para. 4.8.6	: Second sentence amended	221379
		Table 2	: Symbols amended and in Test Conditions, reference paragraph numbers amended	221379
		Table 6	: Table completely rewritten	221379
'A'	Jan. '98	P1. Cover page		None
		P2. DCN		None
		P6. Table 1(a)	: Variant 05 details deleted and annotated "Not to be used"	221420
		P7. Table 1(a)	: Variant 16 details deleted and annotated "Not to be used"	221420
		P8. Table 1(a)	: Notes 4 and 5 amended	221420
		P12. Figure 2	: Variant 05, Title and diagram deleted, "Not to be used" added	221420
		P17. Figure 2	: Variant 16, Title and diagram deleted, "Not to be used" added	221420

**TABLE OF CONTENTS**

	<u>Page</u>
1. <u>GENERAL</u>	5
1.1 Scope	5
1.2 Component Type Variants	5
1.3 Maximum Ratings	5
1.4 Parameter Derating Information	5
1.5 Physical Dimensions	5
2. <u>APPLICABLE DOCUMENTS</u>	5
3. <u>TERMS, DEFINITIONS, ABBREVIATIONS, SYMBOLS AND UNITS</u>	5
4. <u>REQUIREMENTS</u>	22
4.1 General	22
4.2 Deviations from Generic Specification	22
4.2.1 Deviations from Special In-process Controls	22
4.2.2 Deviations from Final Production Tests	22
4.2.3 Deviations from Burn-in and Electrical Measurements	22
4.2.4 Deviations from Qualification Tests	22
4.2.5 Deviations from Lot Acceptance Tests	22
4.3 Mechanical Requirements	22
4.3.1 Dimension Check	22
4.3.2 Weight	22
4.3.3 Contact Capability	22
4.3.4 Contact Retention	23
4.3.5 Mating and Unmating Forces	23
4.3.6 Insert Retention	23
4.3.7 Jackscrew Retention	23
4.3.8 Contact Insertion and Withdrawal Forces	23
4.3.9 Engagement and Separation Forces	23
4.3.10 Oversize Pin Exclusion	23
4.3.11 Probe Damage	23
4.3.12 Solderability	23
4.4 Materials and Finishes	23
4.4.1 Shells	23
4.4.2 Inserts	23
4.4.3 Contacts	23
4.4.4 Contact Retaining Clip	24
4.4.5 Guiding and Locking Devices	24
4.4.6 Magnetism Level	24
4.5 Marking	24
4.5.1 General	24
4.5.2 The SCC Component Number	24
4.5.3 Traceability Information	24
4.6 Electrical Measurements	25
4.6.1 Electrical Measurements at Room Temperature	25
4.6.2 Electrical Measurements at High and Low Temperatures	25
4.6.3 Circuits for Electrical Measurements	25
4.7 Burn-in and Electrical Measurements	25
4.8 Environmental and Endurance Tests	25
4.8.1 Measurements and Inspections on Completion of Environmental Tests	25
4.8.2 Measurements and Inspections at Intermediate Points during Endurance Tests	25
4.8.3 Measurements and Inspections on Completion of Endurance Tests	25
4.8.4 Conditions for Operating Life Tests	25

	ESA/SCC Detail Specification No. 3401/017	PAGE 4 ISSUE 3
---	---	-------------------

4.8.5	Electrical Circuit for Operating Life Tests	<u>Page</u> 25
4.8.6	Conditions for High Temperature Storage Test	25

TABLES

1(a)	Type Variants	6
1(b)	Maximum Ratings	9
2	Electrical Measurements at Room Temperature	26
3	Not applicable	N/A
4	Not applicable	N/A
5	Not applicable	N/A
6	Measurements and Inspections on Completion of Environmental and Endurance Testing	27

FIGURES

1	Parameter Derating Information	N/A
2	Physical Dimensions	10

APPENDICES (Applicable to specific Manufacturers only)

None.

**1. GENERAL****1.1 SCOPE**

This specification details the ratings, physical and electrical characteristics, test and inspection data for Contacts, Electrical, Crimp, Wire-Wrap, Solder and Saver, Gauge 0.6mm, for 3401/016 Connectors.

This specification shall be read in conjunction with:

- ESA/SCC Generic Specification No. 3401, Connectors, Electrical, Non-Filtered, Circular and Rectangular,
- ESA/SCC Detail Specification No. 3401/016, Connectors, Electrical, Printed Circuit Board, Removable Contacts, Crimp, Wire-Wrap, Solder and Saver, based on Type HE801, the requirements of which are supplemented herein.

1.2 COMPONENT TYPE VARIANTS

The different types of contacts specified herein, which are also covered by this specification are scheduled in Table 1(a).

1.3 MAXIMUM RATINGS

The maximum ratings, which shall not be exceeded at any time during use or storage, applicable to the contacts specified herein, are scheduled in Table 1(b).

1.4 PARAMETER DERATING INFORMATION (FIGURE 1)

Not applicable.

1.5 PHYSICAL DIMENSIONS

The physical dimensions of the contacts specified herein are shown in Figure 2.

2. APPLICABLE DOCUMENTS

The following documents form part of this specification and shall be read in conjunction with it:-

- (a) ESA/SCC Generic Specification No. 3401, Connectors, Electrical, Non-Filtered, Circular and Rectangular.
- (b) ESA/SCC Detail Specification No. 3401/016, Connectors, Electrical, for Printed Circuit Boards, Removable Contacts, Crimp, Wire-Wrap, Solder and Saver, based on Type HE801.

3. TERMS, DEFINITIONS, ABBREVIATIONS, SYMBOLS AND UNITS

For the purpose of this specification, the terms, definitions, abbreviations, symbols and units specified in ESA/SCC Basic Specification No. 21300 shall apply.



ESA/SCC Detail Specification
No. 3401/017

Rev. 'A'

PAGE 6

ISSUE 3

TABLE 1(a) - TYPE VARIANTS

VAR- IANT	TYPE	MATING END SIZE Ø mm	BARREL SIZE	RATED CUR- RENT MAX A	ACCEPT WIRE AWG	MAX WEIGHT g	ENGAGEMENT & SEPARATION		TEST PINS		CONTACT CAPABILITY		CON- TACT RETENT. FORCE MAX N	CONTACT INSERT WITHDR FORCES MAX N	PROBE DAMAGE		OVERSIZE PIN EXCL.			
							ENGAG. FORCES N (1)	SEPAR. FORCES N (1)	DIA mm	max.	Pick-up (2) g	Drop (3) g			MO- MENT N.cm	PROBE DIA mm		FORCE MAX N	TEST PIN DIA mm	
																min.	max.		min	max
01 (6)	MC	0.6	N/A	5.0	N/A	0.18	-	-	-	-	-	40 (4) 25 (5)	20	-	-	-	-			
02 (6)	MC	0.6	N/A	5.0	N/A	0.21	-	-	-	-	-	40 (4) 25 (5)	20	-	-	-	-			
03 (6)	MC	0.6	N/A	5.0	N/A	0.22	-	-	-	-	-	40 (4) 25 (5)	20	-	-	-	-			
04	MR	0.6	22	5.0	22-24 26	0.20	-	-	-	-	-	40 (4) 25 (5)	20	-	-	-	-			
05 (6)	NOT TO BE USED																			
06 (6)	MD	0.6	N/A	5.0	N/A	0.18	-	-	-	-	-	40 (4) 25 (5)	20	-	-	-	-			
07 (6)	MD	0.6	N/A	5.0	N/A	0.18	-	-	-	-	-	40 (4) 25 (5)	20	-	-	-	-			
08 (6)	MS	0.6	22	5.0	22 24	0.22	-	-	-	-	-	40 (4) 25 (5)	20	-	-	-	-			
10 (6)	MY	0.6	N/A	5.0	26-28 30	0.29	-	-	-	-	-	40 (4) 25 (5)	20	-	-	-	-			
11 (6)	MY	0.6	N/A	5.0	26-28 30	0.21	-	-	-	-	-	40 (4) 25 (5)	20	-	-	-	-			
12 (6)	FC	0.6	N/A	5.0	N/A	0.125	-	0.90 0.14	0.620 0.575	- 14	90 -	40 (4) 25 (5)	20	0.5	0.59	0.61	0.9	0.758 0.762		

NOTES: See Page 8.



ESA/SCC Detail Specification
No. 3401/017

Rev. 'A'

PAGE 7
ISSUE 3

TABLE 1(a) - TYPE VARIANTS

VAR- IANT	TYPE	MATING END SIZE Ø mm	BARREL SIZE	RATED CUR- RENT MAX A	ACCEPT WIRE AWG	MAX WEIGHT g	ENGAGEMENT & SEPARATION			CONTACT CAPABILITY			CON- TACT RETENT. FORCE MAX N	CONTACT INSERT WITHDR FORCES MAX N	PROBE DAMAGE			OVERSIZE PIN EXCL.	
							ENGAG. FORCES N (1)	SEPAR. FORCES N (1)	TEST PINS DIA mm	WEIGHT		MO- MENT N.cm			PROBE DIA mm		FORCE MAX N	TEST PIN DIA mm	
										Pick-up (2) g	Drop (3) g				min.	max.		min	max
13 (6)	FC	0.6	N/A	5.0	N/A	0.15	0.90	0.14	0.90	0.620	0.575	0.625	0.580	0.5	0.59	0.61	0.9	0.758	0.762
14 (6)	FC	0.6	N/A	5.0	N/A	0.155	0.90	0.14	0.90	0.620	0.575	0.625	0.580	0.5	0.59	0.61	0.9	0.758	0.762
15	FR	0.6	22	5.0	22-24 26	0.145	0.90	0.14	0.90	0.620	0.575	0.625	0.580	0.5	0.59	0.61	0.9	0.758	0.762
16 (6)	NOT TO BE USED																		
17 (6)	FD	0.6	N/A	5.0	N/A	0.12	0.90	0.14	0.90	0.620	0.575	0.625	0.580	0.5	0.59	0.61	0.9	0.758	0.762
18 (6)	FD	0.6	N/A	5.0	N/A	0.12	0.90	0.14	0.90	0.620	0.575	0.625	0.580	0.5	0.59	0.61	0.9	0.758	0.762
19 (6)	FS	0.6	22	5.0	22-24	0.165	0.90	0.14	0.90	0.620	0.575	0.625	0.580	0.5	0.59	0.61	0.9	0.758	0.762
21 (6)	FY	0.6	N/A	5.0	26-28 30	0.16	0.90	0.14	0.90	0.620	0.575	0.625	0.580	0.5	0.59	0.61	0.9	0.758	0.762
22 (6)	FY	0.6	N/A	5.0	26-28 30	0.155	0.90	0.14	0.90	0.620	0.575	0.625	0.580	0.5	0.59	0.61	0.9	0.758	0.762
64 (6)	ML	0.6	N/A	5.0	N/A	0.19	-	-	-	-	-	-	-	-	-	-	-	-	-
65 (6)	ML	0.6	N/A	5.0	N/A	0.21	-	-	-	-	-	-	-	-	-	-	-	-	-

NOTES: See Page 8.



SCC

ESA/SCC Detail Specification

No. 3401/017

Rev. 'A'

PAGE 8

ISSUE 3

TABLE 1(a) - TYPE VARIANTS

VAR- IANT	TYPE	MATING END SIZE Ø mm	BARREL SIZE	RATED CUR- RENT MAX A	ACCEPT WIRE	MAX WEIGHT g	ENGAGEMENT & SEPARATION		TEST PINS			CONTACT CAPABILITY			CON- TACT RETENT. FORCE MAX N	CON- TACT INSERT WITHDR FORCES MAX N	PROBE DAMAGE		OVERSIZE PIN EXCL.	
							ENGAG. FORCES N (1)	SEPAR. FORCES N (1)	DIA mm		Pick-up (2) g	Drop (3) g	MO- MENT N.cm	PROBE DIA mm			FORCE MAX N	TEST PIN DIA mm		
									min.	max.				min				max	min	max
66 (6)	ML	0.6	N/A	5.0	N/A	0.24	-	-	-	-	-	-	-	-	20	-	-	-	-	-
67 (6)	FM	0.6	N/A	5.0	N/A	0.12	0.90	0.14	0.620 0.575	0.625 0.580	- 14	90 -	40 (4) 25 (5)	20	0.5	0.59	0.61	0.9	0.758	0.762
68 (6)	FL	0.6	N/A	5.0	N/A	0.125	0.90	0.14	0.620 0.575	0.625 0.580	- 14	90 -	40 (4) 25 (5)	20	0.5	0.59	0.61	0.9	0.758	0.762
69 (6)	FL	0.6	N/A	5.0	N/A	0.135	0.90	0.14	0.620 0.575	0.625 0.580	- 14	90 -	40 (4) 25 (5)	20	0.5	0.59	0.61	0.9	0.758	0.762
70 (6)	FL	0.6	N/A	5.0	N/A	0.16	0.90	0.14	0.620 0.575	0.625 0.580	- 14	90 -	40 (4) 25 (5)	20	0.5	0.59	0.61	0.9	0.758	0.762

NOTES

- 1st line, maximum values with maximum diameter test pin;
2nd line, minimum values with minimum diameter test pin.
- With minimum diameter test pin and minimum insertion depth of 5.0mm.
- With maximum diameter test pin and minimum insertion depth of 5.0mm.
- Tension.
- Compression.
- These variants are delivered mounted in the inserts and dimensions of the rear part are given in ESA/SCC Detail Specification No. 3401/016.

**TABLE 1(b) - MAXIMUM RATINGS**

No.	CHARACTERISTICS	SYMBOL	MAXIMUM RATING	UNIT	REMARKS
1	Rated Current	I_{CR}	See Table 1(a)	A	
2	Operating Temperature Range	T_{op}	- 55 to + 125	°C	
3	Storage Temperature Range	T_{stg}	- 55 to + 125	°C	
4	Soldering Temperature	T_{sol}	+ 260	°C	Note 1

NOTES

1. Duration 10 seconds maximum and the same contact shall not be resoldered until 3 minutes have elapsed.

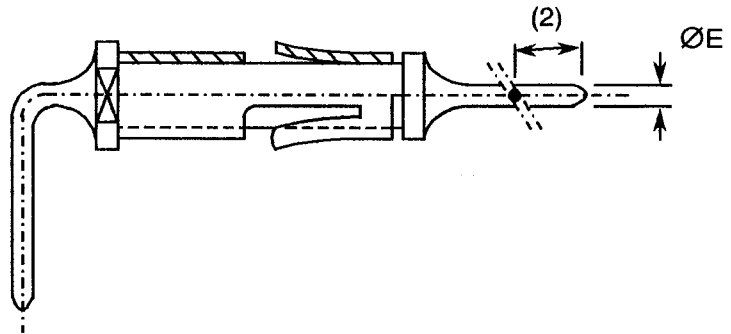
FIGURE 1 - PARAMETER DERATING INFORMATION

Not applicable.

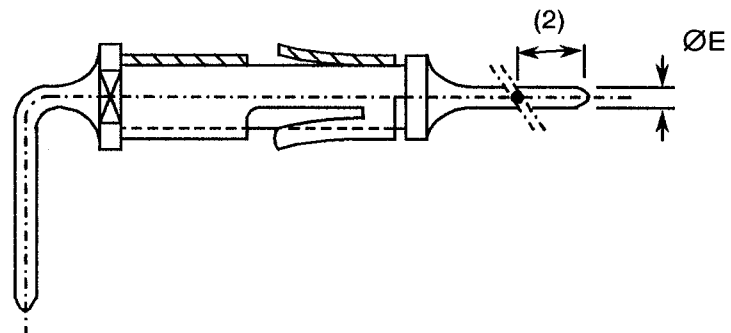


FIGURE 2 - PHYSICAL DIMENSIONS

VARIANT 01 - SOLDER RIGHT-ANGLE MALE CONTACT



VARIANT 02 - SOLDER RIGHT-ANGLE MALE CONTACT



SYMBOL	MILLIMETRES	
	MIN.	MAX.
ØE	0.58	0.62

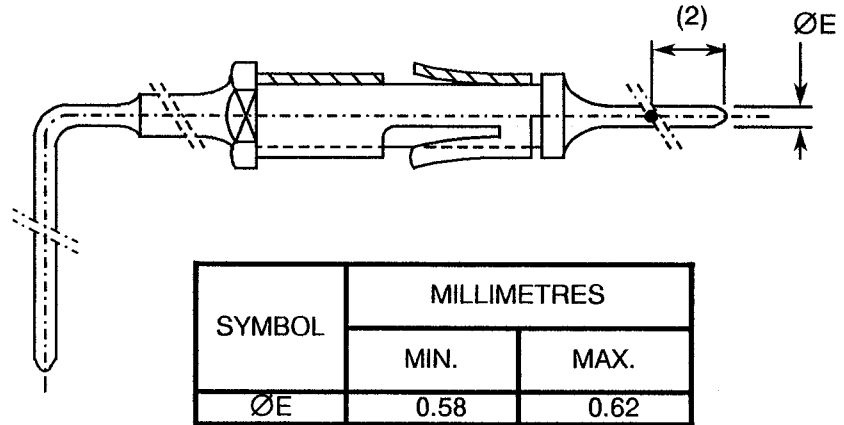
NOTES

1. All dimensions are in millimetres.
2. Measurement point for plating thickness: 2.0 ± 1.0 mm.

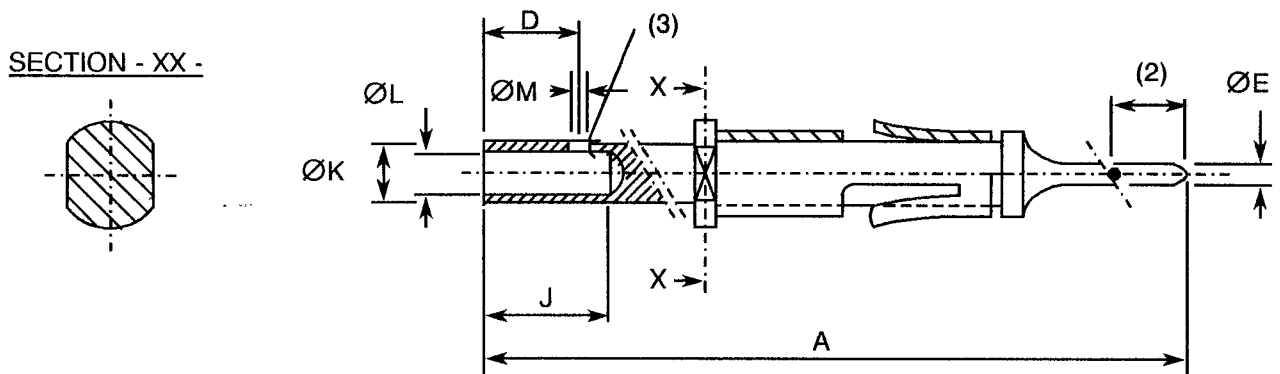


FIGURE 2 - PHYSICAL DIMENSIONS (CONTINUED)

VARIANT 03 - SOLDER RIGHT-ANGLE MALE CONTACT



VARIANT 04 - CRIMP MALE CONTACT



NOTES

1. All dimensions are in millimetres.
2. Measurement point for plating thickness: 2.0 ± 1.0 mm.
3. Inspection hole shall only penetrate one wall of the crimp barrel.

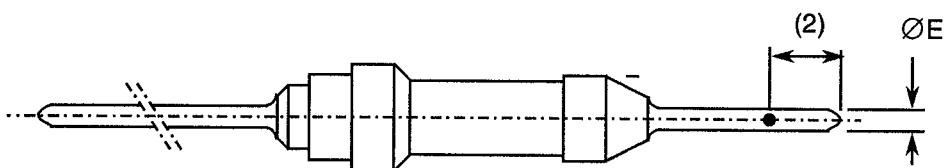


FIGURE 2 - PHYSICAL DIMENSIONS (CONTINUED)

VARIANT 05 - NOT TO BE USED

VARIANT 06 - SOLDER STRAIGHT-THROUGH MALE CONTACT

(Not to be used for new design)



SYMBOL	MILLIMETRES	
	MIN.	MAX.
ØE	0.58	0.62

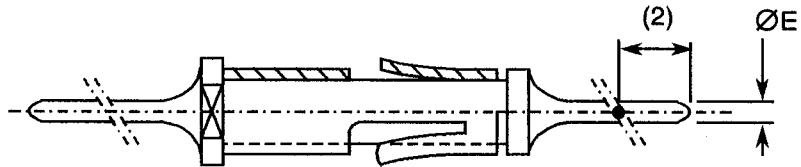
NOTES

1. All dimensions are in millimetres.
2. Measurement point for plating thickness: 2.0 ± 1.0 mm.

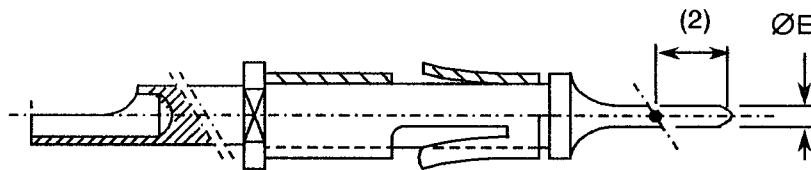


FIGURE 2 - PHYSICAL DIMENSIONS (CONTINUED)

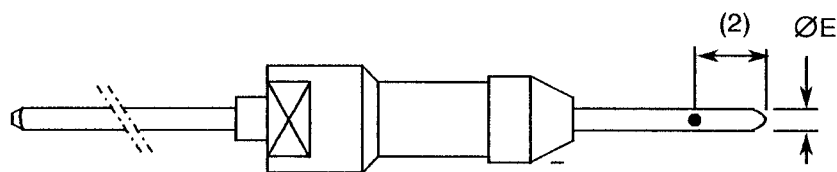
VARIANT 07 - SOLDER STRAIGHT-THROUGH MALE CONTACT



VARIANT 08 - SOLDER BUCKET MALE CONTACT



VARIANT 10 - WIRE-WRAP MALE CONTACT



SYMBOL	MILLIMETRES	
	MIN.	MAX.
ØE	0.58	0.62

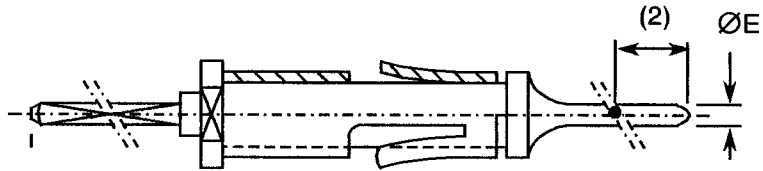
NOTES

1. All dimensions are in millimetres.
2. Measurement point for plating thickness: 2.0 ± 1.0 mm.



FIGURE 2 - PHYSICAL DIMENSIONS (CONTINUED)

VARIANT 11 - WIRE-WRAP MALE CONTACT



SYMBOL	MILLIMETRES	
	MIN.	MAX.
ØE	0.58	0.62

NOTES

1. All dimensions are in millimetres.
2. Measurement point for plating thickness: 2.0 ± 1.0 mm.

VARIANT 12 - SOLDER RIGHT-ANGLE FEMALE CONTACT

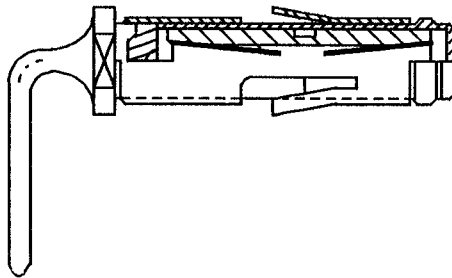
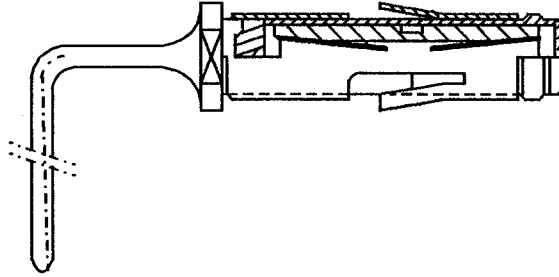




FIGURE 2 - PHYSICAL DIMENSIONS (CONTINUED)

VARIANT 13 - SOLDER RIGHT-ANGLE FEMALE CONTACT



VARIANT 14 - SOLDER RIGHT-ANGLE FEMALE CONTACT

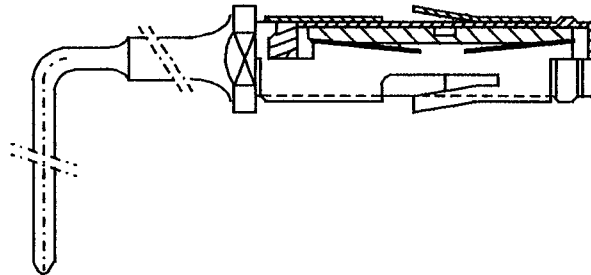
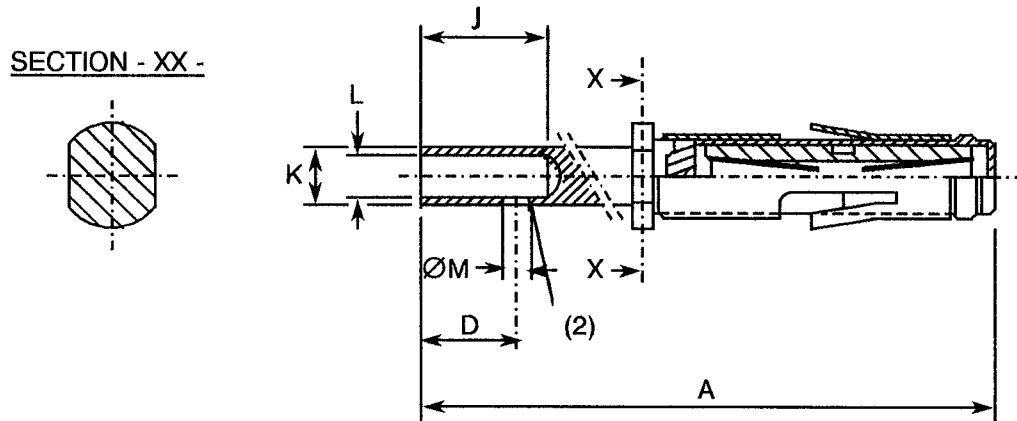




FIGURE 2 - PHYSICAL DIMENSIONS (CONTINUED)

VARIANT 15 - CRIMP FEMALE CONTACT



SYMBOL	MILLIMETRES	
	MIN.	MAX.
A	11.40	12.20
D	3.20	4.10
J	3.80	-
K	1.23	1.50
L	0.85	0.95
ØM	0.40	0.60

NOTES

1. All dimensions are in millimetres.
2. Inspection hole shall only penetrate one wall of the crimp barrel.



		ESA/SCC Detail Specification No. 3401/017	Rev. 'A'	PAGE 17 ISSUE 3
---	---	--	----------	--------------------

FIGURE 2 - PHYSICAL DIMENSIONS (CONTINUED)

VARIANT 16 - NOT TO BE USED

VARIANT 17 - SOLDER STRAIGHT-THROUGH FEMALE CONTACT

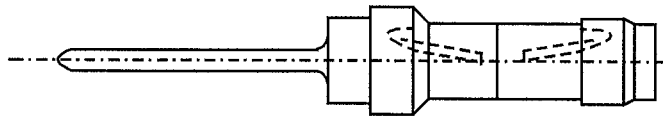
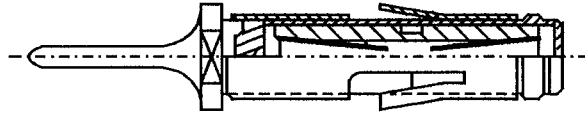


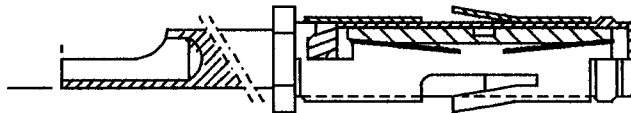


FIGURE 2 - PHYSICAL DIMENSIONS (CONTINUED)

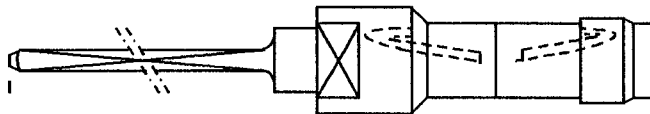
VARIANT 18 - SOLDER STRAIGHT-THROUGH FEMALE CONTACT



VARIANT 19 - SOLDER BUCKET FEMALE CONTACT



VARIANT 21 - WIRE-WRAP FEMALE CONTACT



VARIANT 22 - WIRE-WRAP FEMALE CONTACT

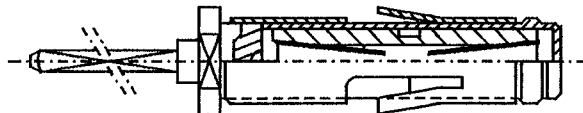
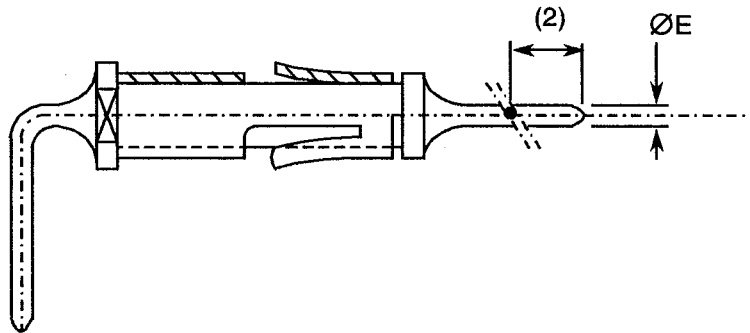


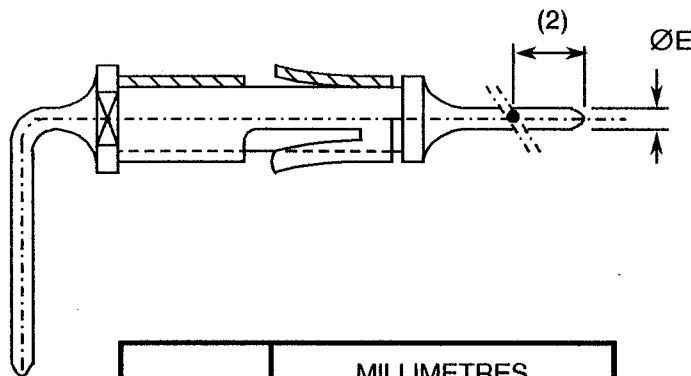


FIGURE 2 - PHYSICAL DIMENSIONS (CONTINUED)

VARIANT 64 - SOLDER RIGHT-ANGLE MALE CONTACT (LONG)



VARIANT 65 - SOLDER RIGHT-ANGLE MALE CONTACT (LONG)



SYMBOL	MILLIMETRES	
	MIN.	MAX.
ØE	0.58	0.62

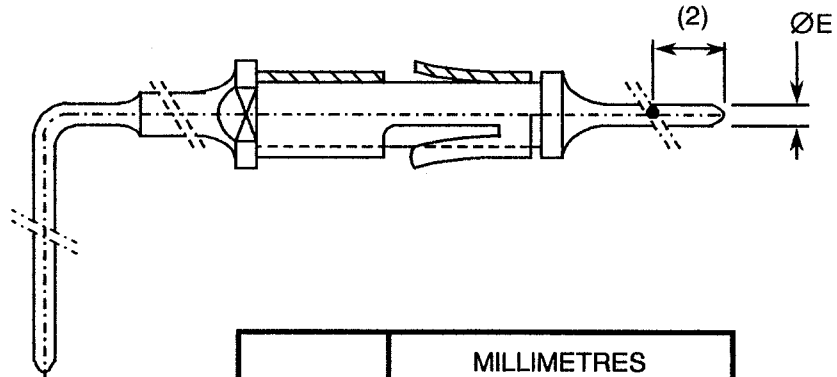
NOTES

1. All dimensions are in millimetres.
2. Measurement point for plating thickness: 2.0 ± 1.0 mm.



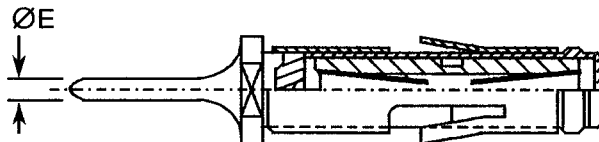
FIGURE 2 - PHYSICAL DIMENSIONS (CONTINUED)

VARIANT 66 - SOLDER RIGHT-ANGLE MALE CONTACT



SYMBOL	MILLIMETRES	
	MIN.	MAX.
ØE	0.58	0.62

VARIANT 67 - SAVER FEMALE - MALE CONTACT



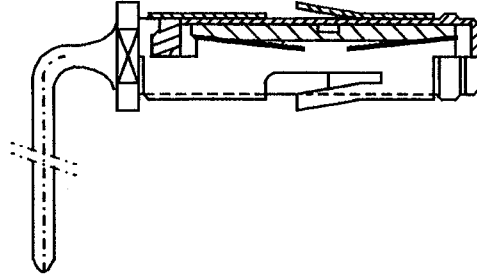
NOTES

1. All dimensions are in millimetres.
2. Measurement point for plating thickness: 2.0 ± 1.0 mm.

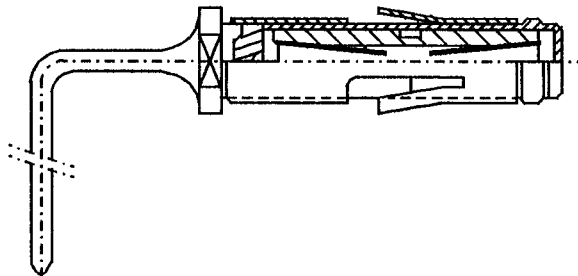


FIGURE 2 - PHYSICAL DIMENSIONS (CONTINUED)

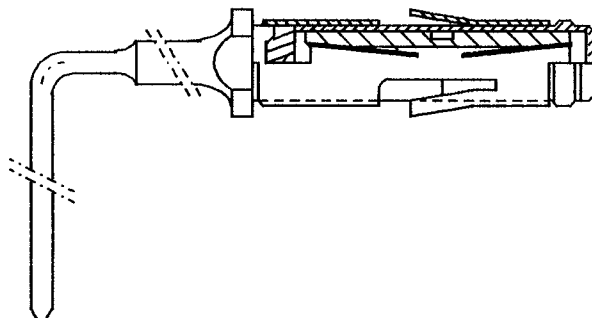
VARIANT 68 - SOLDER RIGHT-ANGLE FEMALE CONTACT



VARIANT 69 - SOLDER RIGHT-ANGLE FEMALE CONTACT



VARIANT 70 - SOLDER RIGHT-ANGLE FEMALE CONTACT





4. REQUIREMENTS

4.1 GENERAL

The complete requirements for procurement of the contacts specified herein are stated in this specification and ESA/SCC Generic Specification No. 3401. Deviations from the Generic Specification, applicable to this specification only, are listed in Para. 4.2.

Deviations from the applicable Generic Specification and this Detail Specification, formally agreed with specific Manufacturers on the basis that the alternative requirements are equivalent to the ESA/SCC requirements and do not affect the components' reliability, are listed in the appendices attached to this specification.

4.2 DEVIATIONS FROM GENERIC SPECIFICATION

4.2.1 Deviations from Special In-process Controls

None.

4.2.2 Deviations from Final Production Tests (Chart II)

(a) Para. 9.4, Contact Capability: Sampling in accordance with Para. 9.6 of ESA/SCC 3401.

4.2.3 Deviations from Burn-in and Electrical Measurements (Chart III)

Not applicable.

4.2.4 Deviations from Qualification Tests (Chart IV)

(a) Para. 9.22, Corrosion: Not applicable.

(b) Para. 9.31, Solderability: Not applicable to Variants 04, 10, 11,15, 21 and 22.

4.2.5 Deviations from Lot Acceptance Tests (Chart V)

(a) Para. 9.22, Corrosion: Not applicable.

(b) Para. 9.31, Solderability: Not applicable to Variants 04, 10, 11,15, 21 and 22.

4.3 MECHANICAL REQUIREMENTS

4.3.1 Dimension Check

The dimensions of the contacts specified herein shall be verified in accordance with the requirements set out in Para. 9.6 of ESA/SCC Generic Specification No. 3401 and shall conform to those shown in Figure 2 of this specification. Overall dimensions are specified with compatible inserts in ESA/SCC Detail specification No. 3401/016.

4.3.2 Weight

The maximum weight of the contacts specified herein shall be as specified in Table 1(a).

4.3.3 Contact Capability

For the purpose of this test, the pick-up and drop weights shall be as specified in Table 1(a).

4.3.4 Contact Retention (in insert)

The contact retention force shall be as specified in Table 1(a).

**4.3.5 Mating and Unmating Forces**

As specified in ESA/SCC Detail Specification No. 3401/016.

4.3.6 Insert Retention (In Shell)

As specified in ESA/SCC Detail Specification No. 3401/016.

4.3.7 Jackscrew Retention

As specified in ESA/SCC Detail Specification No. 3401/016.

4.3.8 Contact Insertion and Withdrawal Forces

The contact insertion and withdrawal forces shall be as specified in Table 1(a).

4.3.9 Engagement and Separation Forces

The diameter of the test pin and the engagement and separation forces of the female contacts shall be as specified in Table 1(a).

4.3.10 Oversize Pin Exclusion

The diameter of the test pin and the force applied to it shall be as specified in Table 1(a).

4.3.11 Probe Damage

The probe diameter and the moment at the end of the probe shall be as specified in Table 1(a).

4.3.12 Solderability

Not applicable to Variants 04, 10, 11, 15, 21 and 22. For all other variants, size B soldering iron shall be used.

4.4 MATERIALS AND FINISHES

The materials and finishes shall be as specified herein. Where a definite material is not specified, a material which will enable the contacts specified herein to meet the performance requirements of this specification shall be used. Acceptance or approval of any constituent material does not guarantee acceptance of the finished product.

4.4.1 Shells

As specified in ESA/SCC Detail Specification No. 3401/016.

4.4.2 Inserts

As specified in ESA/SCC Detail Specification No. 3401/016.

4.4.3 Contacts**4.4.3.1 Body**

The contact body shall be made of copper alloy.

- Male Contact and Saver

The plating shall be 1.27µm minimum gold over 1.27µm minimum nickel.

- Female Contact

The plating shall be 0.25µm minimum gold over 1.27µm minimum nickel.



4.4.3.2 Female Contact Wire

The wire shall be made of copper alloy.

The plating shall be 1.27µm minimum gold over 0.20µm minimum nickel.

4.4.3.3 Female Contact Sleeve

The sleeve shall be made of copper alloy. The plating shall be 0.25µm minimum gold over 0.8µm minimum nickel.

4.4.4 Contact Retaining Clip

The clip shall be made of a beryllium copper alloy with an appropriate surface treatment.

4.4.5 Guiding and Locking Devices

As specified in ESA/SCC Detail Specification No. 3401/016.

4.4.6 Magnetism Level

As specified in ESA/SCC Detail Specification No. 3401/016.

4.5 MARKING

4.5.1 General

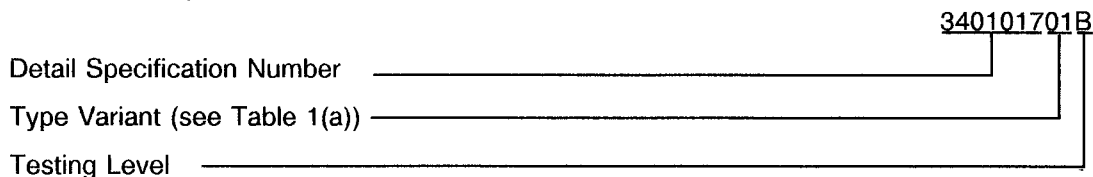
The marking of all components delivered to this specification shall be in accordance with the requirements of ESA/SCC Basic Specification No. 21700 and the following paragraphs.

These components being too small to accommodate the marking as specified hereafter, the full marking information shall accompany each lot of components in its primary package. Such marking shall comprise:-

- (a) The SCC Component Number.
- (b) Traceability information.

4.5.2 The SCC Component Number

The SCC Component Number shall be constituted and marked as follows:-



4.5.3 Traceability Information

Traceability information shall be marked in accordance with ESA/SCC Basic Specification No. 21700.



4.6 ELECTRICAL MEASUREMENTS

4.6.1 Electrical Measurements at Room Temperature

The parameters to be measured in respect of electrical characteristics are scheduled in Table 2. Unless otherwise specified, the measurements shall be performed at $T_{amb} = +22 \pm 3$ °C.

4.6.2 Electrical Measurements at High and Low Temperatures (Table 3)

Not applicable.

4.6.3 Circuits for Electrical Measurements (Figure 4)

Not applicable.

4.7 BURN-IN AND ELECTRICAL MEASUREMENTS

Not applicable.

4.8 ENVIRONMENTAL AND ENDURANCE TESTS (CHARTS IV AND V OF ESA/SCC GENERIC SPECIFICATION No. 3401)

4.8.1 Measurements and Inspections on Completion of Environmental Tests

The parameters to be measured and inspections to be performed on completion of environmental testing are scheduled in Table 6. Unless otherwise specified, the measurements shall be performed at $T_{amb} = +22 \pm 3$ °C.

4.8.2 Measurements and Inspections at Intermediate Points during Endurance Tests

Not applicable.

4.8.3 Measurements and Inspections on Completion of Endurance Tests

The parameters to be measured and inspections to be performed on completion of endurance testing are scheduled in Table 6. Unless otherwise specified, the measurements shall be performed at $T_{amb} = +22 \pm 3$ °C.

4.8.4 Conditions for Operating Life Tests (Part of Endurance Testing)

Not applicable.

4.8.5 Electrical Circuit for Operating Life Tests (Figure 5)

Not applicable.

4.8.6 Conditions for High Temperature Storage Test (Part of Endurance Testing)

The requirements for the high temperature storage test are specified in Section 9 of ESA/SCC Generic Specification No. 3401. The conditions for high temperature storage testing shall be the maximum storage temperature specified in Table 1(b) of this specification.

**ESC**ESA/SCC Detail Specification
No. 3401/017

PAGE 26

ISSUE 3

TABLE 2 - ELECTRICAL MEASUREMENTS AT ROOM TEMPERATURE

No.	CHARACTERISTICS	SYMBOL	SPEC. AND/OR TEST METHOD	TEST CONDITION	VARIANTS	LIMITS		UNIT
						MIN.	MAX.	
1	Contact Resistance (Low Level Current)	Rcl	ESA/SCC No. 3401 Para 9.1.1.3	Para 9.1.1.3	All	-	8.0	mΩ
2	Contact Resistance (Rated Current)	Rcr	ESA/SCC No. 3401 Para 9.1.1.3	Para 9.1.1.3 5.0A	All	-	8.0	mΩ

TABLES 3, 4 AND 5

Not applicable.



TABLE 6 - MEASUREMENTS AND INSPECTIONS ON COMPLETION OF ENVIRONMENTAL AND ENDURANCE TESTING

NO.	ESA/SCC GENERIC NO. 3401		MEASUREMENTS AND INSPECTIONS		SYMBOL	LIMITS		UNIT
	ENVIRONMENTAL AND ENDURANCE TESTS (1)	TEST METHOD AND CONDITIONS	IDENTIFICATION	CONDITIONS		MIN	MAX	
01	Seal Test	Para. 9.9	ESA/SCC 3401/016					
02	Wiring	Para. 9.10 & Table 1(a) of this spec.	Low Level Contact Resistance	Table 2 Item 1	Rcl	Table 2 Item 1		
03	Vibration	Para. 9.11	ESA/SCC 3401/016					
04	Shock or Bump	Para. 9.12	ESA/SCC 3401/016					
05	Climatic Sequence	Para. 9.13	ESA/SCC 3401/016					
06	Plating Thickness	Para. 9.14	Thickness	-	-	Para. 4.4.3 of this spec		
07	Joint Strength	Para. 9.15	ESA/SCC 3401 Para 9.15					
08	Rapid Change of Temperature	Para. 9.16	ESA/SCC 3401/016					
09	Contact Retention (in insert)	Para. 9.17 & Para. 4.3.4 of this spec.	Contact Displacement		-	ESA/SCC 3401 Para. 9.17		
10	Endurance	Para. 9.18	Initial Measurements Low Level Contact Resist	Table 2 Item 1	Rcl	Record Values		
			Final Measurements Low Level Contact Resistance Drift	Table 2 Item 1	ΔRcl	-	4.0	mΩ
11	Permanence of Marking	Para. 9.19	As applicable					
12	Mating/Unmating Forces	Para. 9.20	ESA/SCC 3401/016					
13	High Temperature Storage	Para. 9.21	Initial Measurements Low Level Contact Resist	Table 2 Item 1	Rcl	Record Values		
			Final Measurements Low Level Contact Resistance Drift	Table 2 Item 1	ΔRcl	-	4.0	mΩ
			Rated Current Contact Resistance	Table 2 Item 2	Rcr	Table 2 Item 2		
			Contact Retention (in insert)	Para. 4.3.4 of this spec.	-	ESA/SCC 3401 Para. 9.17		
14	Corrosion	Para. 9.22	Visual Examination					

NOTES

1. The tests in this table refer to either Chart IV or V and shall be used as applicable.



TABLE 6 - MEASUREMENTS AND INSPECTIONS ON COMPLETION OF ENVIRONMENTAL AND ENDURANCE TESTING (CONTINUED)

NO.	ESA/SCC GENERIC NO. 3401		MEASUREMENTS AND INSPECTIONS		SYMBOL	LIMITS		UNIT
	ENVIRONMENTAL AND ENDURANCE TESTS (1)	TEST METHOD AND CONDITIONS	IDENTIFICATION	CONDITIONS		MIN	MAX	
15	Insert Retention (in shell)	Para. 9.23 & Para. 4.3.6 of this spec.	ESA/SCC 3401/016					
16	Jackscrew Retention	Para. 9.24 & Para. 4.3.7 of this spec.	ESA/SCC 3401/016					
17	High Temperature Measurements	Para. 9.25	ESA/SCC 3401/016					
18	Overload Test	Para. 9.26	Rated Current Contact Resistance	Table 2 Item 2	Rcr	Table 2 Item 2		
19	Maintenance Aging	Para. 9.27	Visual Examination Contact Retention (in insert) Contact Insertion & Withdrawal Forces	- Para. 4.3.4 of this spec. Para. 4.3.8 of this spec.	- - -	- - ESA/SCC 3401 Para. 9.17 Para. 4.3.8		
20	Engage/Separation Forces	Para. 9.28 & Para. 4.3.9 of this spec.	Force		-	Para. 4.3.9		
21	Oversize Pin Exclusion	Para. 9.29 & Para. 4.3.10 of this spec.			-	ESA/SCC 3401 Para. 9.29		
22	Probe Damage	Para. 9.30 & Para. 4.3.11 of this spec.	Contact Separation Force	Para. 4.3.9 of this spec.	-	Para. 4.3.9		
23	Solderability	Para. 9.31 & Para. 4.3.12 of this spec.				ESA/SCC 3401 Para. 9.31		

NOTES

1. The tests in this table refer to either Chart IV or V and shall be used as applicable.