



**european space agency
agence spatiale européenne**

Pages 1 to 16

**CONNECTORS, MINIATURE, ELECTRICAL,
CIRCULAR, PUSH-PULL COUPLING,
HERMETIC RECEPTACLE,
BASED ON TYPE DBA 7*H
ESA/SCC Detail Specification No. 3401/023**

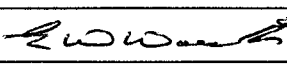
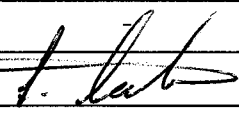

**space components
coordination group**

Issue/Rev.	Date	Approved by	
		SCCG Chairman	ESA Director General or his Deputy
Issue 1	October 1982	-	
Revision 'A'	March 1990		

**SCC**ESA/SCC Detail Specification
No. 3401/023

Rev. 'A'

PAGE 2

ISSUE 1

DOCUMENTATION CHANGE NOTICE

Rev. Letter	Rev. Date	Reference	CHANGE Item	Approved DCR No.
'A'	Mar. '90		This Issue incorporates all modifications agreed on the basis of Policy DCR 21016 for adaptation to new qualification requirements. P1. Cover Page P2. DCN P8. Figure 2 : Dimension corrected	None None 23340
			This document has been transferred from hardcopy to electronic format. The content is unchanged but minor differences in presentation exist.	

**TABLE OF CONTENTS**

	<u>Page</u>
1. <u>GENERAL</u>	5
1.1 Scope	5
1.2 Range of Components	5
1.3 Maximum Ratings	5
1.4 Parameter Derating Information	5
1.5 Physical Dimensions	5
1.6 Functional Diagram	5
2. <u>APPLICABLE DOCUMENTS</u>	10
3. <u>TERMS, DEFINITIONS, ABBREVIATIONS, SYMBOLS AND UNITS</u>	10
4. <u>REQUIREMENTS</u>	10
4.1 General	10
4.2 Deviations from Generic Specification	10
4.2.1 Deviations from Special In-process Controls	10
4.2.2 Deviations from Final Production Tests	10
4.2.3 Deviations from Burn-in Tests	10
4.2.4 Deviations from Qualification, Environmental and Endurance Tests	10
4.2.5 Deviations from Lot Acceptance Tests	11
4.3 Mechanical Requirements	11
4.3.1 Dimension Check	11
4.3.2 Weight	11
4.3.3 Connector Engagement and Separation Forces	11
4.3.4 Insert Retention	11
4.3.5 Contact Retention	11
4.3.6 Hermeticity	12
4.4 Materials and Finishes	12
4.4.1 Shells	12
4.4.2 Inserts	12
4.4.3 Contacts	12
4.4.4 Gaskets	12
4.5 Marking	12
4.5.1 General	12
4.5.2 The SCC Component Number	13
4.5.3 Characteristics	13
4.5.4 Traceability Information	14
4.5.5 Marking of Small Components	14
4.6 Electrical Measurements	15
4.6.1 Electrical Measurements at Room Temperature	15
4.6.2 Electrical Measurements at High and Low Temperatures	15
4.6.3 Circuits for Electrical Measurements	15



	<u>Page</u>
4.7 Screening Tests	15
4.8 Environmental and Endurance Tests	15
4.8.1 Electrical Measurements on Completion of Environmental Tests	15
4.8.2 Electrical Measurements at Intermediate Points during Endurance Tests	15
4.8.3 Electrical Measurements on Completion of Endurance Tests	15
4.8.4 Conditions for Operating Life Tests	15
4.8.5 Electrical Circuits for Operating Life Tests	15
4.8.6 Conditions for High Temperature Storage Test	15

TABLES

1(a) Range of Components	6
1(b) Maximum Ratings	6
2 Electrical Measurements at Room Temperature	16
3 Not Applicable	
4 Not Applicable	
5 Not Applicable	
6 Electrical Measurements after Environmental and Endurance Tests	16

FIGURES

1 Voltage Proof	7
2 Physical Dimensions - Receptacle and Plug	8
2(a) Physical Dimensions - Standard Contact Arrangements	9
2(b) Physical Dimensions - Special Contact Arrangements	9

APPENDICES (Applicable to specific Manufacturers only)

None.



1. GENERAL

1.1 SCOPE

This specification details the ratings, physical and electrical characteristics, test and inspection data for Connectors, Miniature, Electrical, Circular, Push-pull Coupling, Hermetic Receptacle, based on Type DBA 7*H. It shall be read in conjunction with ESA/SCC Generic Specification No. 3401, Connectors, Electrical, Rectangular and Circular, the requirements of which are supplemented herein.

1.2 RANGE OF COMPONENTS

The different sizes of the basic type of connectors specified herein, which are also covered by this specification, together with their mechanical characteristics, are given in Table 1(a).

1.3 MAXIMUM RATINGS

The maximum ratings, which shall not be exceeded at any time during use or storage, applicable to the connectors specified herein, are as scheduled in Table 1(b).

1.4 PARAMETER DERATING INFORMATION

The derating information applicable to the connectors specified herein is shown in Figure 1.

1.5 PHYSICAL DIMENSIONS

The physical dimensions of the connectors specified herein are shown in Figure 2.

1.6 FUNCTIONAL DIAGRAM

Not applicable.

2. APPLICABLE DOCUMENTS

The following documents form part of this specification and shall be read in conjunction with it:-

- (a) ESA/SCC Generic Specification No. 3401, Electrical Connectors, Circular and Rectangular.
- (b) ESA/SCC Detail Specification No. 3401/008, Connectors, Miniature, Electrical, Circular, Push-pull Coupling, Crimp-type Removable Contacts, Based on Type DBAS.
- (c) MIL-STD-202E, Test Methods for Electronic and Electrical Component Parts.
- (d) MIL-STD-1344, Test Methods for Electrical Connectors.
- (e) MIL-G-45204, Gold-plating.



TABLE 1(a) - RANGE OF COMPONENTS

SHELL STYLE	SHELL SIZE	WEIGHT (g) Max.
Receptacle	03	13
Receptacle	07	19
Receptacle	12	25
Receptacle	19	35
Receptacle	27	41
Receptacle	37	45
Receptacle	61	66

TABLE 1(b) - MAXIMUM RATINGS

No.	CHARACTERISTICS	SYMBOL	MAXIMUM RATINGS	UNIT	REMARKS
1	High Temperature	T_{amb}	+ 200	°C	
2	Low Temperature	T_{amb}	- 65	°C	
3	Voltage Proof	V_p	1500	Vrms	
4	Rated Current Contacts #20 #16 #12	I_R	5.0 10 17	A	



FIGURE 1 - VOLTAGE PROOF VERSUS ALTITUDE

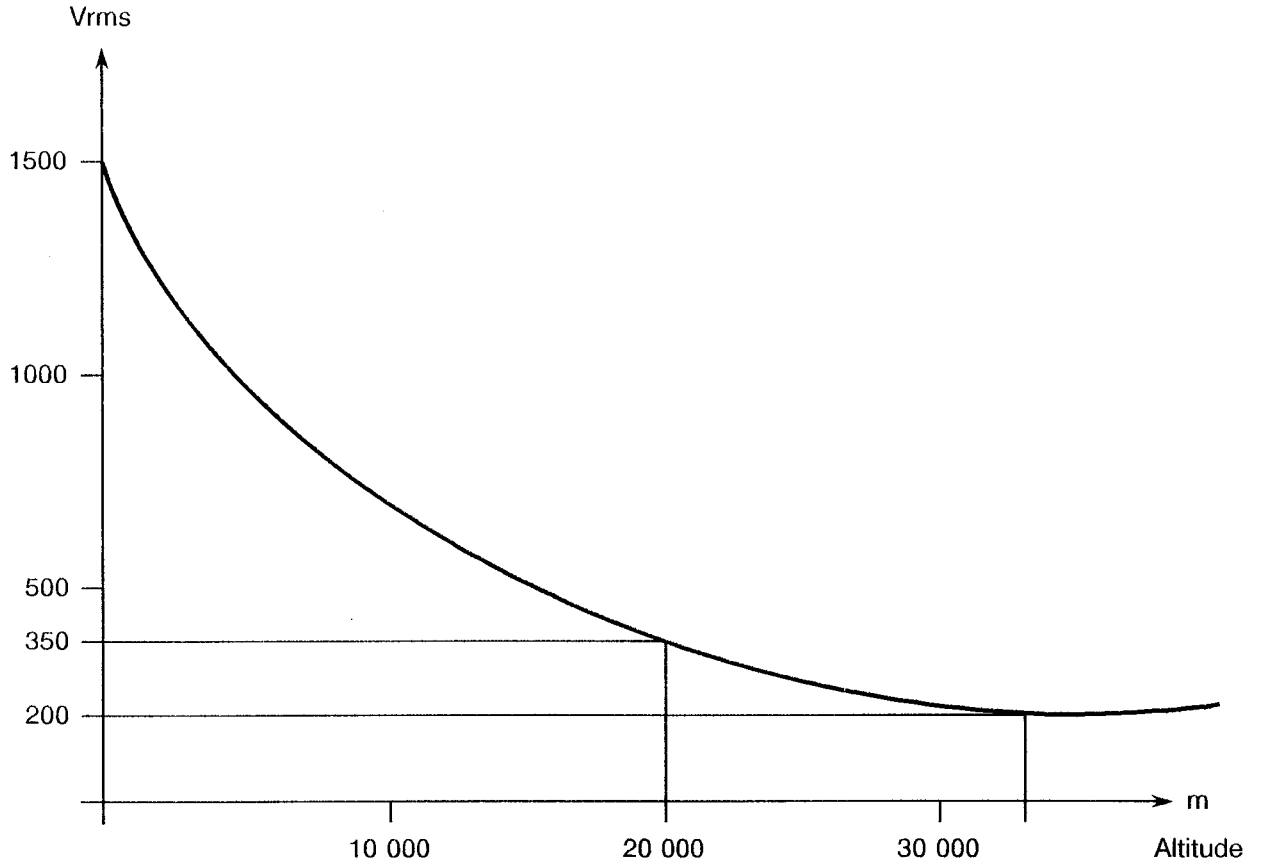

Voltage Proof versus Altitude



FIGURE 2 - PHYSICAL DIMENSIONS

Solder Flange Receptacle

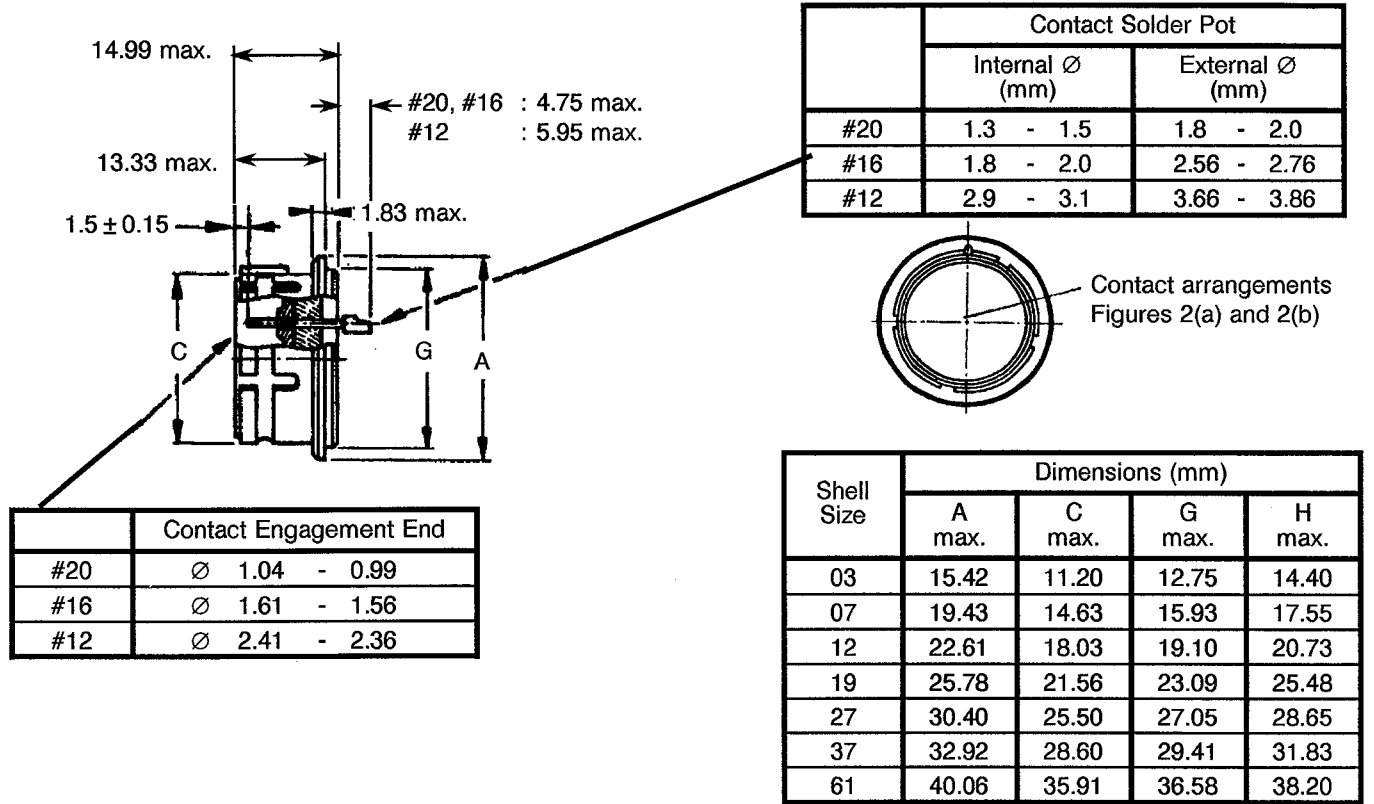

Single Hole Mounting Receptacle

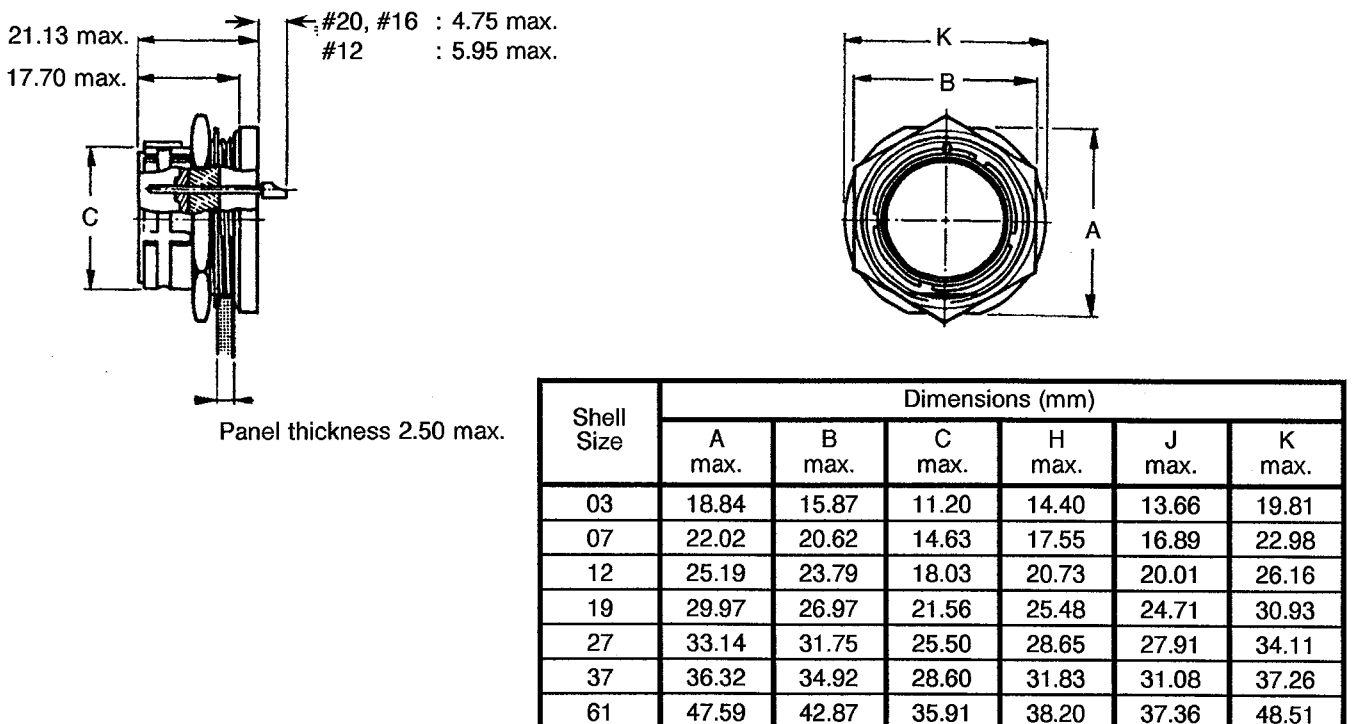
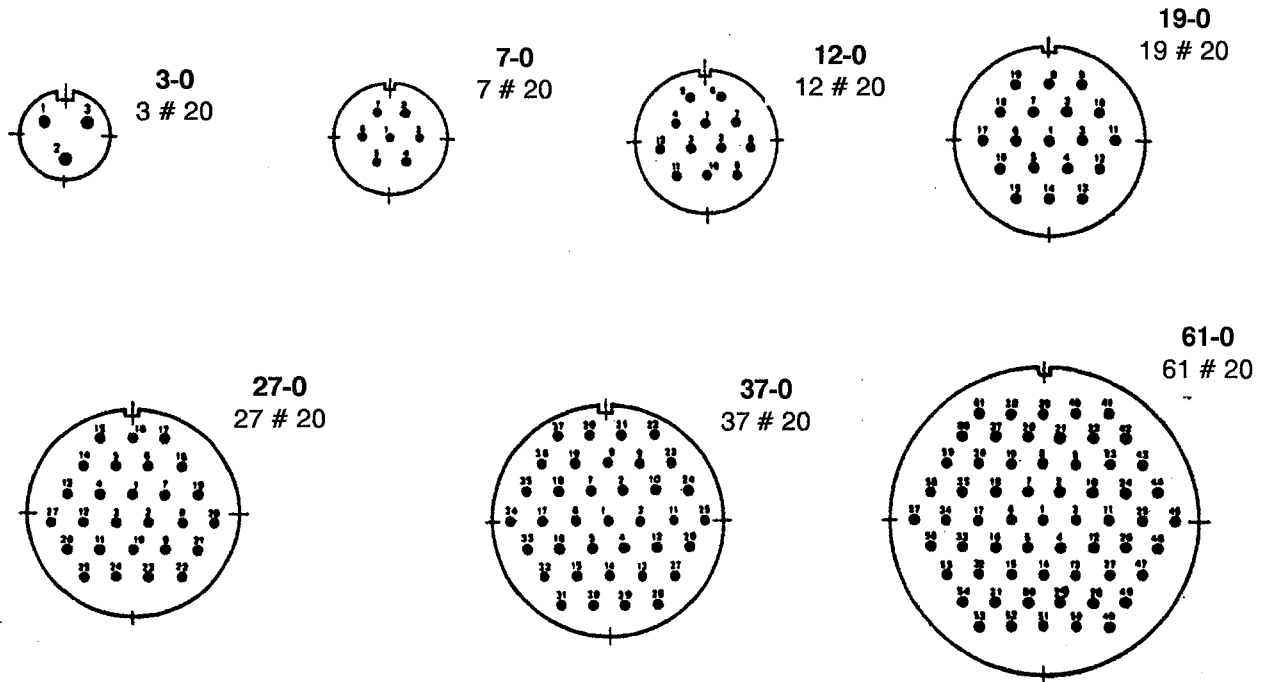

FIGURE 2 - PHYSICAL DIMENSIONS (CONTINUED)

FIGURE 2(a) - STANDARD CONTACT ARRANGEMENTS - FRONT VIEW PIN INSERT
(See Para. 4.5 for definition of numbers)



NOTES

1. Contact locations in conformity with the applicable MS drawing.

FIGURE 2(b) - SPECIAL CONTACT ARRANGEMENTS - FRONT VIEW PIN INSERT
(See Para. 4.5 for definition of numbers)

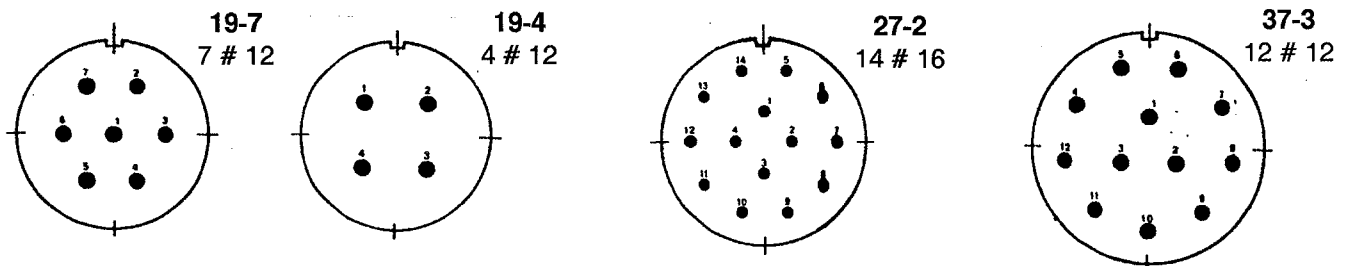



3. TERMS, DEFINITIONS, ABBREVIATIONS, SYMBOLS AND UNITS

For the purpose of this specification, the terms, definitions, abbreviations, symbols and units specified in ESA/SCC Basic Specification No. 21300 shall apply.

4. REQUIREMENTS

4.1 GENERAL

The complete requirements for procurement of the connectors specified herein shall be as stated in this specification and ESA/SCC Generic Specification No. 3401. Deviations from the Generic Specification, applicable to this specification only, are listed in Para. 4.2.

Deviations from the applicable Generic Specification and this Detail Specification, formally agreed with specific Manufacturers on the basis that the alternative requirements are equivalent to the ESA/SCC requirements and do not affect the components' reliability, are listed in the appendices attached to this specification.

4.2 DEVIATIONS FROM GENERIC SPECIFICATION

4.2.1 Deviations from Special In-process Controls

None.

4.2.2 Deviations from Final Production Tests (Chart II)

Para. 9.4, Contact Retainer test: Not applicable.

Para. 9.6, Female Contact Capability test: Not applicable.

Para. 9.7, Magnetism Level: Not applicable.

Add the following test:-

"Hermeticity Test

Each hermetic receptacle shall be submitted to a hermeticity test according to MIL-STD-202, Method 112, Condition C, Procedure I. The leakage rate shall be less than that specified in the Detail Specification."

4.2.3 Deviations from Burn-in Tests (Chart III)

Not applicable.

4.2.4 Deviations from Qualification, Environmental and Endurance Tests (Chart IV)

For the purpose of these tests, where mated connectors are specified, the corresponding plug in the DBAS series (3401/008) shall be used.

4.2.4.1 Subgroup III is not applicable.

4.2.4.2 Add to the end of Subgroups I, II and IV a hermeticity test as specified in Para. 4.2.2 above.



4.2.4.3 Delete all contact tests except No. 9.5, Visual Inspection, No. 9.27, Solderability, No. 28, Contact Resistance and No. 29, Pull Test. These shall be performed on the contacts of Subgroup II connectors and the number of allowable failures is 1.

4.2.4.4 Para. 9.8, Vibration: 20G, 10 - 2000 Hz.

4.2.4.5 Para. 9.9, Mechanical Shock: 100G, 11ms, 1/2 sine wave.

4.2.4.6 Para. 9.13, Thermal Shock: Temperature as specified in Table 1(b).

4.2.4.7 Para. 9.19, High Temperature Test: Temperature as specified in Table 1(b).

4.2.5 Deviations from Lot Acceptance Tests (Chart V)

See Para. 4.2.4 above. Hermeticity tests shall be performed at the end of each subgroup.

4.3 MECHANICAL REQUIREMENTS

4.3.1 Dimension Check

The dimensions of the connectors specified herein shall be checked. They shall conform to those shown in Figure 2.

4.3.2 Weight

The maximum weight of the connectors specified herein shall be as specified in Table 1(a).

4.3.3 Connector Engagement and Separation Forces

The force applied for the engagement and separation of a plug and a receptacle shall conform to the values specified in Table 1(a) of ESA/SCC Detail Specification No. 3401/008.

4.3.4 Insert Retention

Connector inserts shall withstand a pressure of 70 bars and shall meet the hermeticity test requirements.

4.3.5 Contact Retention

Contacts shall be submitted to the following forces applied to their engagement end:-



Contact Size AWG	Force DaN
20	9.0
16	11.5
12	11.5

Subsequently, the connectors shall meet the hermeticity requirements.

4.3.6 Hermeticity

When tested as specified in Para. 4.2.2 above, the leakage rate of the connectors shall be less than 3.10^{-8} cc/sec.

4.4 MATERIALS AND FINISHES

The materials and finishes shall be as specified herein. Where a definite material is not specified, a material which will enable the connectors specified herein to meet the performance requirements of this specification shall be used. Acceptance or approval of any constituent material does not guarantee acceptance of the finished product.

4.4.1 Shells

Stainless steel.

4.4.2 Inserts

Glass.

4.4.3 Contacts

Ferro-nickel, gold-plated, thickness 1.27μ minimum, Ni underplate.

4.4.4 Gaskets

Bonded, silicone.

4.5 MARKING

4.5.1 General

The marking of all components delivered to this specification shall be in accordance with the requirements of ESA/SCC Basic Specification No. 21700 and the following paragraphs. Each component shall be marked in respect of:-

- (a) The SCC Component Number.
- (b) Characteristics.
- (c) Traceability Information.



4.5.2 The SCC Component Number

The SCC Component Number shall be constituted and marked as follows:

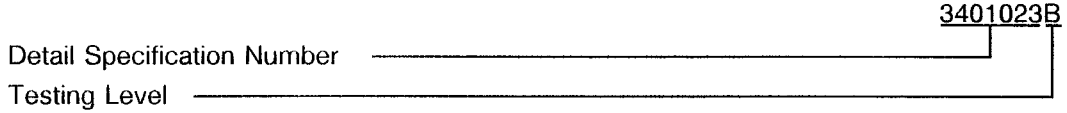

4.5.3 Characteristics

The characteristics to be marked in the following order of precedence are:-

- (a) Connector series.
- (b) Shell type.
- (c) Hermeticity.
- (d) Shell size.
- (e) Contact arrangement.
- (f) Type of contact.
- (g) Insert clocking position.
- (h) Modification.

The information shall be constituted and marked as follows:-

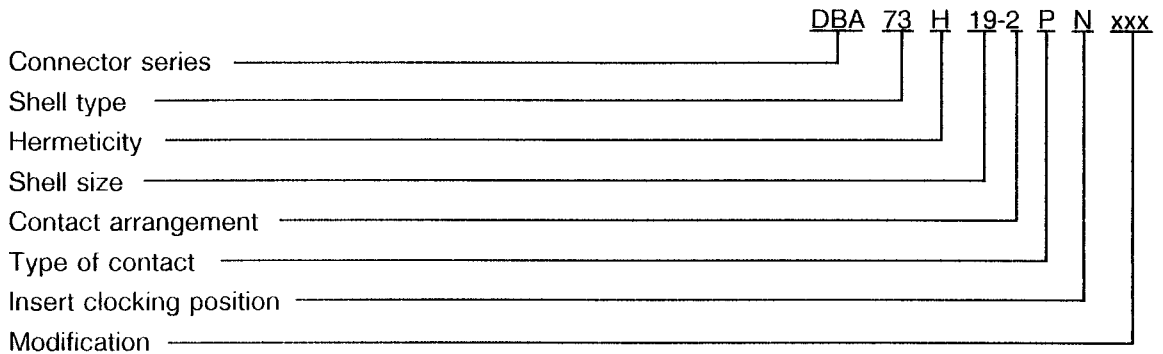

4.5.3.1 Connector Series

This connector series shall be designated by the letters 'DBA'.

4.5.3.2 Shell Type

The shell types shall be designated by the following numbers:-

Code No.	Shell Type
74	Single-hole mounting receptacle
73	Solder flange receptacle

4.5.3.3 Hermeticity

Hermetic receptacles are designated by the letter 'H'.

4.5.3.4 Shell Sizes and Contact Arrangements

Shell sizes and contact arrangements are closely related to each other and shall be indicated by the following codes:-

CODE	Number of Contacts
Shell Size - Contact Arrangement	
3 - 0	Numbers of contacts and contact sizes are as shown in Figures 2(a) and 2(b)
7 - 0	
12 - 0	
19 - 0	
19 - 4	
19 - 7	
27 - 0	
27 - 2	
27 - 5	
37 - 0	
37 - 3	
61 - 0	

4.5.3.5 Type of Contact

The contact type shall be indicated by the following letter code:-

Letter Code	Contact Type
P	Male

4.5.3.6 Modification Codes

Modification codes shall be expressed in letters or numbers, or both. They shall be defined by the Manufacturer, who shall keep a code register for reference purposes. When there is no modification of the standard product, no code shall appear.

4.5.4 Traceability Information

Traceability information shall be marked in accordance with the requirements of ESA/SCC Basic Specification No. 21700.

4.5.5 Marking of Small Components

When it is considered that the component is too small to accommodate the marking as specified above, as much as space permits shall be marked. The order of precedence shall be as specified in Para. 4.5.1.

The marking information, in full, shall accompany each component in its primary package.



4.6 ELECTRICAL MEASUREMENTS

4.6.1 Electrical Measurements at Room Temperature

The parameters to be measured in respect of electrical characteristics are scheduled in Table 2. Unless otherwise specified, the measurements shall be performed at $T_{amb} = +22 \pm 3$ °C.

4.6.2 Electrical Measurements at High and Low Temperatures (Table 3)

Not applicable.

4.6.3 Circuits for Electrical Measurements

Not applicable.

4.7 SCREENING TESTS (TABLES 4 AND 5)

Not applicable.

4.8 ENVIRONMENTAL AND ENDURANCE TESTS

4.8.1 Electrical Measurements on Completion of Environmental Tests

The parameters to be measured on completion of environmental tests shall be specified in the test sequence of ESA/SCC Generic Specification No. 3401. Unless otherwise stated, the measurements shall be performed at $T_{amb} = +22 \pm 3$ °C.

4.8.2 Electrical Measurements at Intermediate Points during Endurance Tests

Not applicable.

4.8.3 Electrical Measurements on Completion of Endurance Tests

The parameters to be measured on completion of endurance testing shall be those specified in Table 6 and the test sequence of ESA/SCC Generic Specification No. 3401. Unless otherwise stated, the measurements shall be performed at $T_{amb} = +22 \pm 3$ °C.

4.8.4 Conditions for Operating Life Tests (Part of Endurance Testing)

Not applicable.

4.8.5 Electrical Circuits for Operating Life Tests

Not applicable.

4.8.6 Conditions for High Temperature Storage Test (Part of Endurance Testing)

The requirements for the high temperature storage test are specified in Section 9 of ESA/SCC Generic Specification No. 3401. The conditions for high temperature storage shall be $T_{amb} = +200(+0 - 3)$ °C.



TABLE 2 - ELECTRICAL MEASUREMENTS AT ROOM TEMPERATURE

No.	CHARACTERISTICS	SYMBOL	SPEC. AND/OR TEST METHOD	TEST CONDITIONS	LIMITS		UNIT
					MIN.	MAX.	
1	Insulation Resistance	I_R	MIL-STD-202 Method 302	B	10 000	-	$M\Omega$
2	Voltage Proof	V_P	MIL-STD-1344 Method 3001	-	1 500	-	Vrms

TABLES 3, 4 AND 5

Not applicable.

FIGURE 3 - MEASUREMENT POINTS FOR CONTACT RESISTANCE

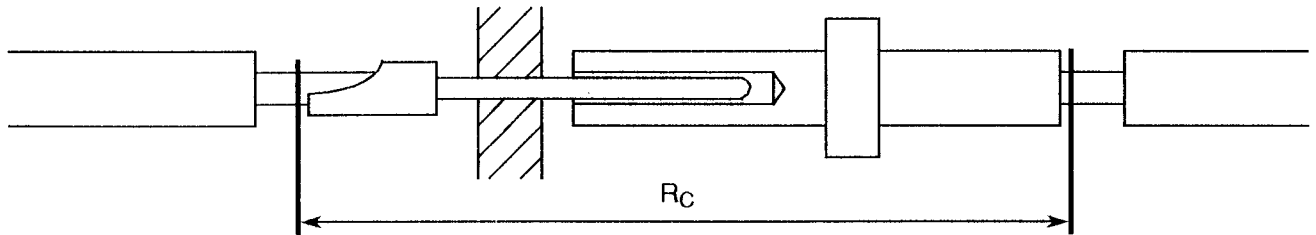

ELECTRICAL MEASUREMENTS AFTER ENVIRONMENTAL AND ENDURANCE TESTS

No.	CHARACTERISTICS	SYMBOL	SPEC. AND/OR TEST METHOD	TEST CONDITIONS	LIMITS		UNIT
					MIN.	MAX.	
1	Insulation Resistance	I_R	MIL-STD-202 Method 302	B	500	-	$M\Omega$
2	Contact Resistance	R_C	ESA/SCC Gen. Spec. No. 3401 Para. 9.28 and Figure 3	Contact Size #20 I = 5.0A	-	28	m Ω
				Contact Size #16 I = 10A	-	21	
				Contact Size #12 I = 17A	-	14	