

**DOCUMENTATION CHANGE NOTICE**

Rev. Letter	Rev. Date	Reference	CHANGE Item	Approved DCR No.
		This Issue supersedes Issue 2 and incorporates all modifications defined in Revisions 'A', 'B' and 'C' to Issue 2 and the changes agreed in the following DCRs:-		
		Cover page		None
		DCN		None
		Para. 1.1	: Reference to ESA/SCC Detail Spec. No. 3401/028 deleted	221610
		Table 1(a)	: Item (b) deleted and Item (c) renumbered : FR136, FR136A weight added to Table, Column split and Shell Size 9 amended	221610 23941
		Table 1(b)	: Note 1 amended	221610
		Table 1(b)	: Working Voltage amended	23941
		Table 1(b)	: Rated Current details added as new Items 2 and 3, existing Items renumbered	221610
		Figure 1	: Retitled as Figure 1(a) and completely amended	221610
		Figure 1(b)	: New Figure added	221610
		Figure 2.1	: Split into Figures 2.1A and 2.1B	221610
		Figure 2.1A	: Dimension L in drawing and Dimensions B, F and G in Table underlined	221610
		Figure 2.1B	: Note 2 added : Dimension L in drawing and Dimensions B, F and G in Table underlined	221610 221610
		Figure 2.2A	: Note 2 added : Split into Figures 2.2A and 2.2B	221610 221610
		Figure 2.2B	: Side Elevation deleted, Elevation added : Detail A extracted to separate drawing : Dimensions B, C, D and E in Table underlined : Values for Dimension J added	221610 221610 221610 221610
		Figure 2.2C	: Split into Figures 2.2C and 2.2D	221610
		Figure 2.2E	: Side Elevation deleted, Elevation added : Detail A extracted to separate drawing : Dimensions B, C, D and E in Table underlined : Values for Dimension J added	221610 221610 221610 221610
		Figure 2.2F	: Split into Figures 2.2E and 2.2F : Side Elevation deleted, Elevation added : Dimensions Nmin, Nmax, Pmin and U amended : Detail A extracted to separate drawing : Dimensions B, C, D and E in Table underlined : Detail A extracted to separate drawing : PCB layout drawing amended : Dimensions B, D, E, F and N in Table underlined	221610 221610 221610 221610 221610 221610 221610 221610
		Figure 2.2G	: Side Elevation deleted, Elevation added : Dimensions Nmin, Nmax, Pmin and U amended : Detail A extracted to separate drawing : Dimensions B, C, D and E in Table underlined : Detail A extracted to separate drawing : PCB layout drawing amended : Dimensions B, D, E, F and N in Table underlined	221610 221610 221610 221610 221610 221610 221610
		Figure 2.3	: Split into Figures 2.2G and 2.2H	221610
		Figure 2.2G	: Side Elevation deleted, Elevation added	221610



DOCUMENTATION CHANGE NOTICE

Rev. Letter	Rev. Date	Reference	CHANGE Item	Approved DCR No.
			: Dimensions D, E, Gmin, Gmax, J, K1, Mmin, Mmax, Nmin, Nmax, Pmin and U amended	221610
			: Detail A extracted to separate drawing	221610
		Figure 2.2H	: Dimensions B, C, D, E, F and N underlined	221610
			: Side Elevation deleted, Elevation added	221610
			: Dimensions D, E, Gmin, Gmax, J, K1, Mmin, Mmax, Nmin, Nmax, Pmin and U amended	221610
			: Detail A extracted to separate drawing	221610
		Figure 2.3B	: Dimensions B, C, D and E in Table underlined	221610
		Figure 2.3.1	: Figure deleted	221610
		Figure 2.3.2	: New Figure added	221610
		Figure 2.3.3	: New Figure added	221610
		Figure 2.6	: New Figure added	221610
		Figure 3	: Table added	221610
			: Figure 3 inserted	221610
			: "Typical" added to Notes to Contact Centre drawing	221610
		Para. 2	: Items (b), (h) and (i) deleted and remaining Items renumbered	221610
		Para. 4.2	: Existing deviations deleted for all Charts and New Deviations added	221610
		Para. 4.3.1	: New sentence added	221610
		Para. 4.3.2	: References to ESA/SCC Detail Spec. No. 3401/028 deleted	221610
		Para. 4.3.3	: Contact Capability added	23941
		Para. 4.3.4	: (In insert) added to title	23941
			: Force amended	23941
		Para. 4.3.5	: Mating and Unmating Forces added	23941
		Para. 4.3.6	: Insertion Retention (In shell) added	23941
		Para. 4.3.7	: In DCR 221610 renumbered to 4.3.9	23941
			: Jackscrew Retention added	23941
		Para. 4.3.8	: Contact Insertion and Withdrawal Force (Male Contacts) added	23941
		Para. 4.3.9	: Engagement and Separation Forces (Male Contacts) added	221610
		Para. 4.3.10	: Oversize Pin Exclusion added	23941
		Para. 4.3.11	: Probe Damage added	23941
		Para. 4.3.12	: Solderability added	23941
		Para. 4.4.1	: Text amended	221610
		Para. 4.4.2	: Text amended	221610
		Para. 4.4.3	: New paragraph added and all paragraphs subsequent to "4.4.3" renumbered	221610/ 23941
		Para. 4.4.7	: (Was 4.4.6) Text amended	221610
		Para. 4.5.3	: Text amended to "Mounting" in 2 places from "Floating Mount or Captive Nut"	23941
		Para. 4.5.3.4	: Title amended to "Mounting"	221610
		Table 2	: Old Table deleted	221610
			: New table inserted and amended	221610/ 23941
		Figure 4	: New figure inserted	221610
		Table 6	: Old Table deleted New Table inserted	23941



DOCUMENTATION CHANGE NOTICE

Rev. Letter	Rev. Date	Reference	CHANGE Item	Approved DCR No.
'A'	Mar. '02	P1. Cover page		None
		P3A DCN		None
		P6. Para. 2(c)	: Voltage amended to 600V	23950
		P21. Fig 2.2F	: Title amended; "Plug" deleted, "Receptacle" inserted	23950
		P22. Fig 2.2F (Cont)	: Title amended; "Plug" deleted, "Receptacle" inserted	23950
		P24.	: Shell size 9, dimension D amended to 19.94	23950
			: Dimension E1 underlined	
		P26.	: Shell size 9, dimension D amended to 19.94	23950
			: Dimension E1 underlined	23950
			: For shell sizes 9 to 37 Dimension " <u>N</u> Min." amended to read "4.0" and " <u>N</u> Max." amended to read "4.2"	23950
		P27. Fig. 2.3.2	: Diagram amended	23950
		P32. Para. 4.3.4	: New sentence added	23950
		P40. Table 6	: No. 19, "Maintenance Ageing" "Not Applicable" inserted in Limits Column	23950
'B'	Sept. '02	P1. Cover page		None
		P3A. DCN		None
		P7. Table 1(a)	: Last two Table Column Headings corrected	23961
		P24. Figure 2.2G	: Dimensions A max., B min. and B max. corrected for shell sizes 15 and 25	23961
		P26. Figure 2.2H	: Dimensions A max., B min. and B max. corrected for shell sizes 15 and 25	23961
		P32. Para. 4.3.5	: In the text, "engagement and separation" corrected to "mating and unmating"	23961
		P39. Table 6	: Item 02, Limit added	23961
			: Item 03 in CONDITIONS, "ESCC 3601" and "Vibration" deleted	23961
			: Item 05, in SYMBOL, "VP" deleted	23961
			: , in LIMITS, the last Item corrected to "Table 2, Item 2".	23961
	: Item 08, in LIMITS, the last Item corrected to "Table 2, Item 2"	23961		

**TABLE OF CONTENTS**

	<u>Page</u>
1. <u>GENERAL</u>	6
1.1 Scope	6
1.2 Range of Components	6
1.3 Maximum Ratings	6
1.4 Parameter Derating Information	6
1.5 Physical Dimensions	6
1.6 Contact Arrangements	6
2. <u>APPLICABLE DOCUMENTS</u>	6
3. <u>TERMS, DEFINITIONS, ABBREVIATIONS, SYMBOLS AND UNITS</u>	6
4. <u>REQUIREMENTS</u>	31
4.1 General	31
4.2 Deviations from Generic Specification	31
4.2.1 Deviations from Special In-process Controls	31
4.2.2 Deviations from Final Production Tests	31
4.2.3 Deviations from Burn-in and Electrical Measurements	31
4.2.4 Deviations from Qualification Tests	31
4.2.5 Deviations from Lot Acceptance Tests	31
4.3 Mechanical Requirements	32
4.3.1 Dimension Check	32
4.3.2 Weight	32
4.3.3 Contact Capability	32
4.3.4 Contact Retention (In Insert)	32
4.3.5 Mating and Unmating Forces	32
4.3.6 Insert Retention (In Shell)	32
4.3.7 Jackscrew Retention	32
4.3.8 Contact Insertion and Withdrawal Forces	32
4.3.9 Engagement and Separation Forces	32
4.3.10 Oversize Pin Exclusion	33
4.3.11 Probe Damage	33
4.3.12 Solderability	33
4.4 Materials and Finishes	33
4.4.1 Shells	33
4.4.2 Inserts	33
4.4.3 Contacts	33
4.4.4 Seals, Interfacial	33
4.4.5 Insulated Wires	33
4.4.6 Uninsulated Solid Wire	33
4.4.7 Rear Potting	33
4.5 Marking	34
4.5.1 General	34
4.5.2 The SCC Component Number	34
4.5.3 Characteristics	34
4.5.4 Traceability Information	35
4.6 Electrical Measurements	35
4.6.1 Electrical Measurements at Room Temperature	35
4.6.2 Electrical Measurements at High and Low Temperatures	35
4.6.3 Circuits for Electrical Measurements	35
4.7 Burn-in and Electrical Measurements	35



	<u>Page</u>
4.8 Environmental and Endurance Tests	38
4.8.1 Measurements and Inspection on Completion of Environmental Tests	38
4.8.2 Measurements and Inspections at Intermediate Points during Endurance Tests	38
4.8.3 Measurements and Inspections on Completion of Endurance Tests	38
4.8.4 Conditions for Operating Life Tests	38
4.8.5 Electrical Circuits for Operating Life Tests	38
4.8.6 Conditions for High Temperature Storage Test	38

TABLES

1(a) Range of Components	7
1(b) Maximum Ratings	7
2 Electrical Measurements at Room Temperature	36
3 Not applicable	
4 Not applicable	
5 Not applicable	
6 Measurements and Inspections on Completion of Environmental and Endurance Tests	39

FIGURES

1 Parameter Derating Information	8
2 Physical Dimensions	9
3 Contact Arrangements	30
4 Gauge Fixture	37

APPENDICES (Applicable to specific Manufacturers only)

None.

**1. GENERAL****1.1 SCOPE**

This specification details the ratings, physical and electrical characteristics, test and inspection data of Electrical, Rectangular, Microminiature Connectors with Non-removable Crimp-type Contacts and their associated insulated wires and uninsulated solid wires, based on Type MDM.

It shall be read in conjunction with:

- (a) ESA/SCC Generic Specification No. 3401, Connectors, Electrical, Rectangular and Circular.
- (b) ESA/SCC Detail Specification No. 3401/032, Accessories for Connectors, Microminiature, 3401/029.

the requirements of which are supplemented herein.

1.2 RANGE OF COMPONENTS

The different sizes of the basic type connectors specified herein, which are also covered by this specification, together with their mechanical characteristics, are scheduled in Table 1(a). The different sizes of associated insulated wires and uninsulated solid wires are given in Figure 2.

1.3 MAXIMUM RATINGS

The maximum ratings, which shall not be exceeded at any time during use or storage, applicable to the contacts specified herein, are scheduled in Table 1(b).

1.4 PARAMETER DERATING INFORMATION

The derating information applicable to the contacts specified herein is shown in Figure 1.

1.5 PHYSICAL DIMENSIONS

The physical dimensions of the connectors, insulated wires and uninsulated solid wires specified herein are shown in Figure 2.

1.6 CONTACT ARRANGEMENTS

Contact arrangement are shown in Figure 3.

2. APPLICABLE DOCUMENTS

The following documents form part of this specification and shall be read in conjunction with it:-

- (a) ESA/SCC Generic Specification No. 3401, Connectors, Electrical, Circular and Rectangular.
- (b) ESA/SCC Detail Specification No. 3401/032, Accessories for Connectors, Microminiature for 3401/029.
- (c) ESA/SCC Detail Specification No. 3901/013, PTFE Insulated Wires and Cables, 600V, - 100 to +200°C.
- (d) QQ-W-343, Wires, Electrical Uninsulated.
- (e) MIL-G-45204, Gold Plating, Electro-deposited.
- (f) MIL-C-14550, Copper Plating, Electro-deposited.
- (g) MIL-PRF-83513, Connectors Electrical, Rectangular, Microminiature, Polarised Shell, Generic Specification for.

3. TERMS, DEFINITIONS, ABBREVIATIONS, SYMBOLS AND UNITS

For the purpose of this specification, the terms, definitions, abbreviations, symbols and units specified in ESA/SCC Basic Specification No. 21300 shall apply.



TABLE 1(a) - RANGE OF COMPONENTS

Variant		Shell Size	Max. Weight (grammes)				Mating Force (N.max)	Unmating Force	
Shell Finish			FR112 to 116 and FR123 (1)	FR136 (2)	FR136A (2)	FR139 (2)		N. Max.	N. Min.
Nickel	Gold								
01	02	9	2.2	7.4	7.4	4.6	20	20	1.3
01	02	15	3.0	7.8	N/A	5.0	33	33	2.0
01	02	21	3.8	8.5	N/A	5.4	47	47	2.9
01	02	25	4.3	10.2	N/A	6.5	55	55	3.5
01	02	31	5.1	12.2	N/A	7.7	69	69	4.3
01	02	37	5.9	14.4	N/A	9.2	82	82	5.1
01	02	51	7.2	16.5	N/A	N/A	113	113	7.1

NOTES

- Connector contacts and rear potting, without cables, without floating eyelets and without captive nut. Add 0.4 grammes for connectors with floating mounts and 1.0 gramme for connectors with captive nuts. See Figures 2-4 and 2-5 for the weight of cable.
- Connector with contacts and rear potting.

TABLE 1(b) - MAXIMUM RATINGS

NO.	CHARACTERISTICS	SYMBOL	MAXIMUM RATING	UNIT	REMARKS
1	Working Voltage Sea Level	U_R	150	Vrms	Note 1
2	Rated Current: (AWG26 and uninsulated solid wire)	I_R	2.5	A	
3	Rated Current (AWG28)	I_R	1.5	A	
4	Operating Temperature Range	T_{op}	- 55 to + 125	°C	
5	Storage Temperature Range	T_{stg}	- 55 to + 125	°C	

NOTES

- Between contacts, and contact and shell.



FIGURE 1 - PARAMETER DERATING INFORMATION

FIGURE 1(a) - WORKING VOLTAGE VERSUS ALTITUDE

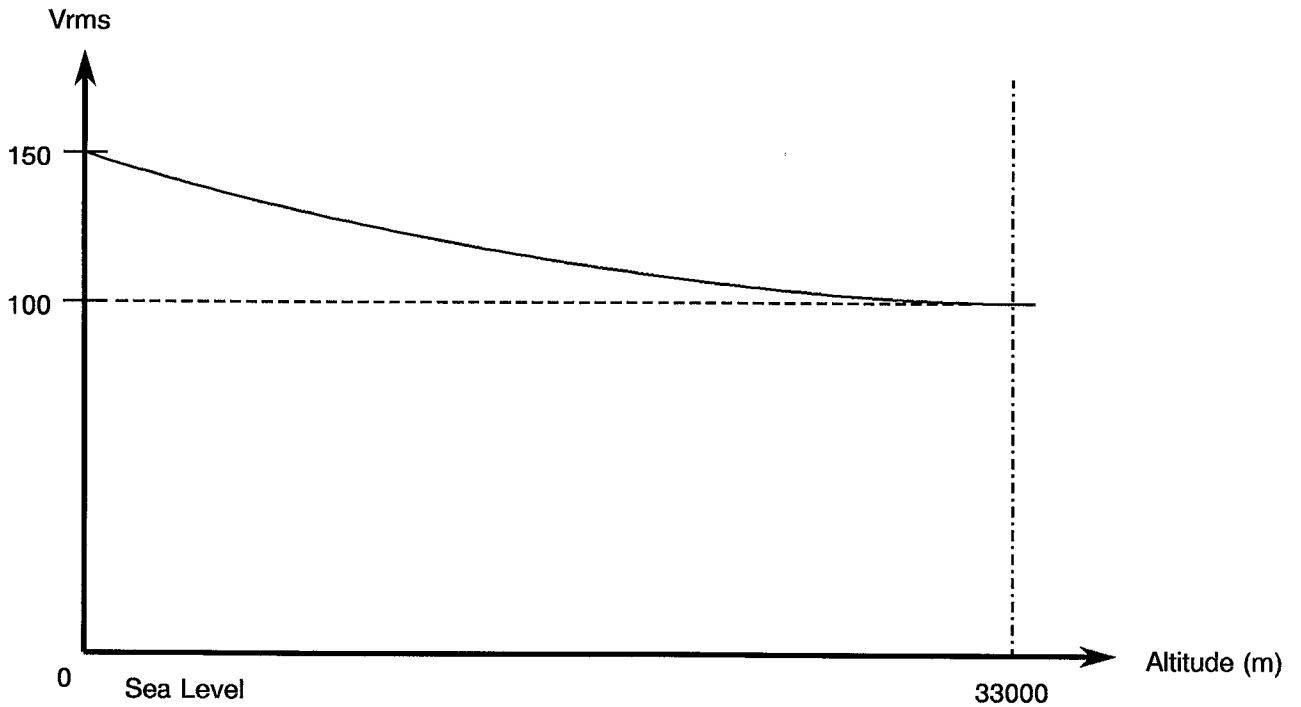


FIGURE 1(b) - MAXIMUM CURRENT VERSUS NUMBER OF CONTACTS

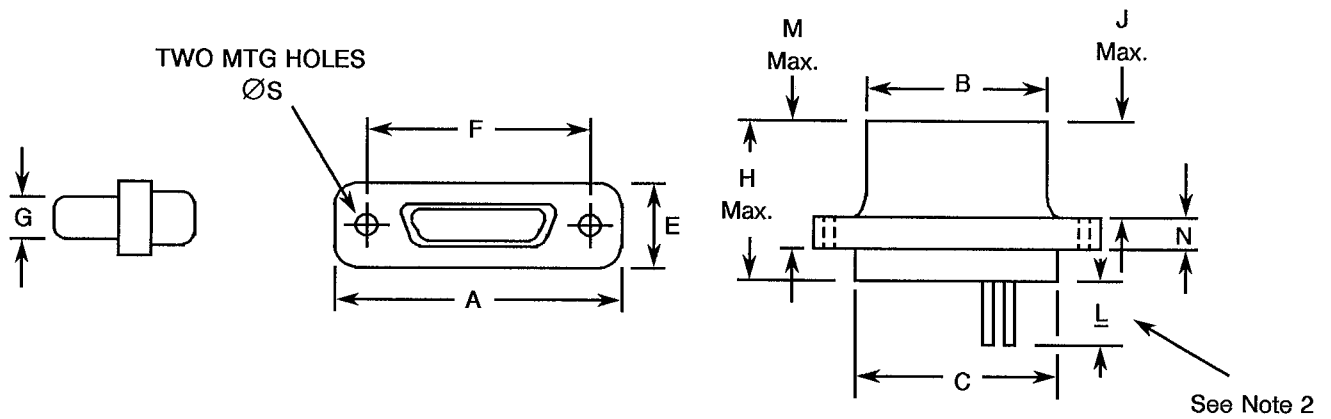
NUMBER OF CONTACTS PER CONNECTOR	MAXIMUM CURRENT PER CONTACT	
	WIRE SIZE	
	AWG 26 AND UNINSULATED SOLID WIRE	AWG 28
2 - 4	2.0	1.4
5 - 14	1.8	1.2
15 and over	1.4	0.9



FIGURE 2 - PHYSICAL DIMENSIONS

FIGURE 2.1A - CONNECTOR SHELLS

PLUG MALE CONTACTS



Shell Size	A Max.	B Max.	C Max.	D Max.	E Max.	E		G Max.	H Max.	J Max.	M Max.	N		ØS	
						Min.	Max.					Min.	Max.	Min.	Max.
9	19.94	8.46	10.16	6.86	7.82	14.22	14.48	4.69	10.57	4.72	7.26	2.23	2.49	2.23	2.39
15	23.75	12.27	13.97	6.86	7.82	18.03	18.29	4.69	10.57	4.72	7.26	2.23	2.49	2.23	2.39
21	27.56	16.08	17.78	6.86	7.82	21.84	22.10	4.69	10.57	4.72	7.26	2.23	2.49	2.23	2.39
25	30.10	18.62	20.32	6.86	7.82	24.38	24.64	4.69	10.57	4.72	7.26	2.23	2.49	2.23	2.39
31	33.91	22.43	24.13	6.86	7.82	28.19	28.45	4.69	10.57	4.72	7.26	2.23	2.49	2.23	2.39
37	37.72	26.24	27.94	6.86	7.82	32.0	32.26	4.69	10.57	4.72	7.26	2.23	2.49	2.23	2.39
51	36.45	24.97	26.67	7.87	8.92	30.73	30.99	5.78	10.57	4.72	7.26	2.23	2.49	2.23	2.39

NOTES

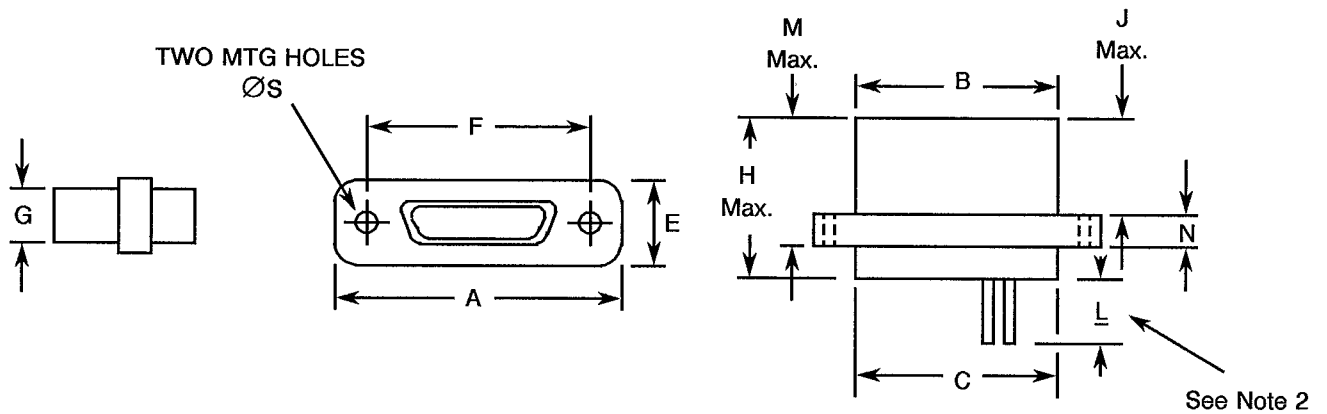
1. All dimensions are in millimetres.
2. For minimum length of 'L' refer to Para. 4.5.3.3 of this specification.



FIGURE 2 - PHYSICAL DIMENSIONS (CONTINUED)

FIGURE 2.1B - CONNECTOR SHELLS

RECEPTACLE FEMALE CONTACTS



Shell Size	A Max.	B Max.	C Max.	D Max.	E Max.	E		G Max.	H Max.	J Max.	M Max.	N		ØS	
						Min.	Max.					Min.	Max.	Min.	Max.
9	19.94	10.16	10.16	6.86	7.82	14.22	14.48	6.38	10.90	5.05	7.59	2.23	2.49	2.23	2.39
15	23.75	13.97	13.97	6.86	7.82	18.03	18.29	6.38	10.90	5.05	7.59	2.23	2.49	2.23	2.39
21	27.56	17.78	17.78	6.86	7.82	21.84	22.10	6.38	10.90	5.05	7.59	2.23	2.49	2.23	2.39
25	30.10	20.32	20.32	6.86	7.82	24.38	24.64	6.38	10.90	5.05	7.59	2.23	2.49	2.23	2.39
31	33.91	24.13	24.13	6.86	7.82	28.19	28.45	6.38	10.90	5.05	7.59	2.23	2.49	2.23	2.39
37	37.72	27.94	27.94	6.86	7.82	32.00	32.26	6.38	10.90	5.05	7.59	2.23	2.49	2.23	2.39
51	36.45	26.67	26.67	7.87	8.92	30.73	30.99	7.47	10.90	5.05	7.59	2.23	2.49	2.23	2.39

NOTES

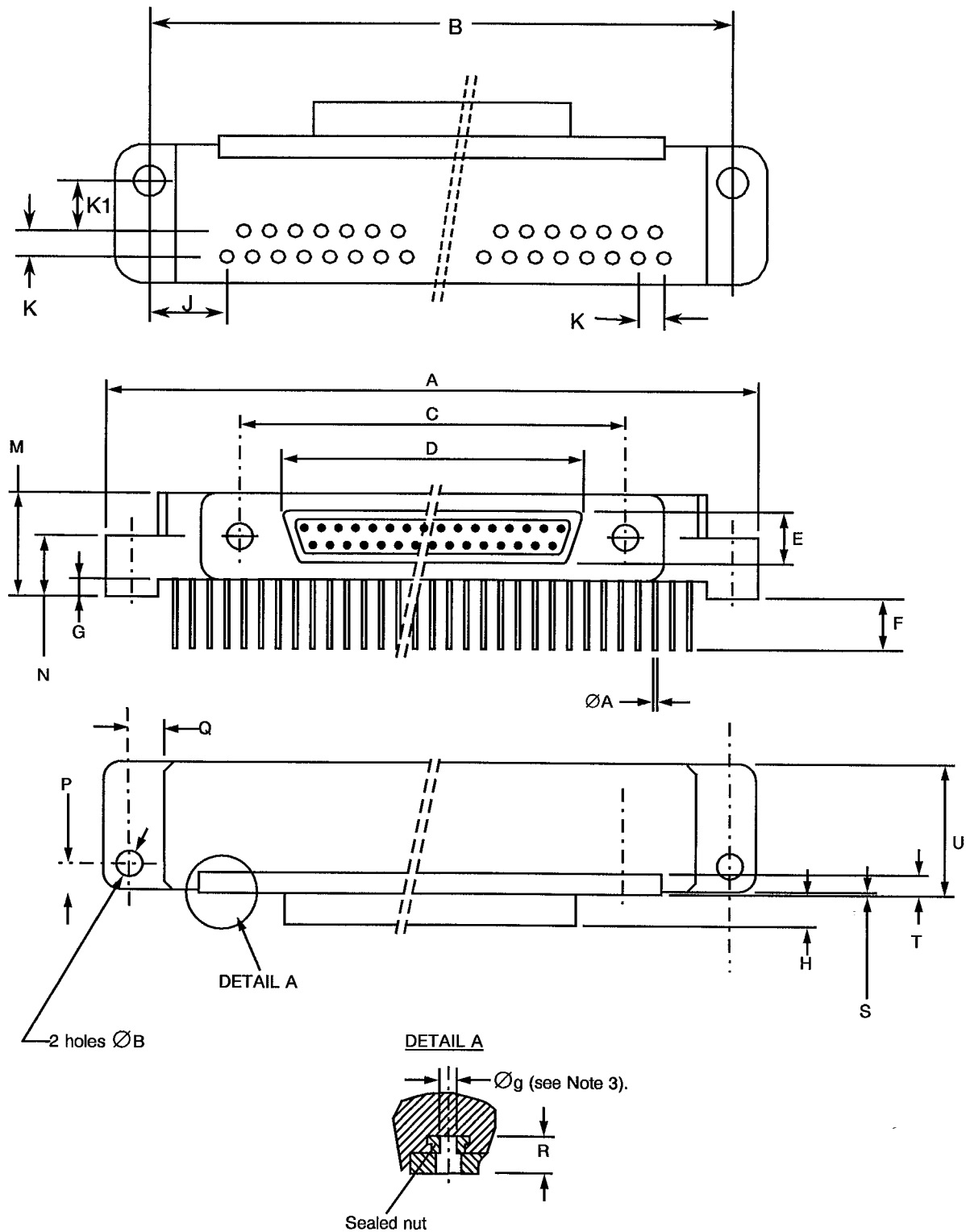
1. All dimensions are in millimetres.
2. For minimum length of 'L' refer to Para. 4.5.3.3 of this specification.



FIGURE 2 - PHYSICAL DIMENSIONS (CONTINUED)

FIGURE 2.2A - CONNECTORS TYPE -FR136

PLUG MALE CONTACTS





SOC

ESA/SCC Detail Specification
No. 3401/029

FIGURE 2 - PHYSICAL DIMENSIONS (CONTINUED)

FIGURE 2.2A - CONNECTOR TYPE - FR136 (CONTINUED)

PLUG MALE CONTACTS (CONTINUED)

Shell Size	A		B		ØB (4)		C		D	E		F		G		H	J
	Max.	Min.	Max.	Min.	Max.	Min.	Max.	Min.	Max.	Max.	Min.	Max.	Min.	Max.	Min.	Max.	Typ.
9	35.31	29.03	29.39	2.31	2.59	14.22	14.48	8.46	4.69	4.15	4.85	1.3	1.7	4.72	9.53		
15	39.12	32.84	33.2	2.31	2.59	18.03	18.29	12.27	4.69	4.15	4.85	1.3	1.7	4.72	7.62		
21	42.93	36.65	37.01	2.31	2.59	21.84	22.1	16.08	4.69	4.15	4.85	1.3	1.7	4.72	5.72		
25	45.47	39.19	39.55	2.31	2.59	24.38	24.64	18.62	4.69	4.15	4.85	1.3	1.7	4.72	4.45		
31	51.82	45.54	45.9	2.31	2.59	28.19	28.45	22.43	4.69	4.15	4.85	1.3	1.7	4.72	3.81		
37	59.44	53.16	53.52	2.31	2.59	32	32.26	26.24	4.69	4.15	4.85	1.3	1.7	4.72	3.81		

Shell Size	K		K1		M		N		P		Q		R		S		T		U
	Typ.	Min.	Max.	Min.	Max.	Min.	Max.	Min.	Max.	Min.	Max.	Min.	Max.	Min.	Max.	Min.	Max.	Min.	Max.
9	2.54	3.56	4.06	9.0	9.2	5.15	5.45	2.79	3.55	2.0	2.1	4.6	0.2	0.4	2.23	2.49	11.56		
15	2.54	3.56	4.06	9.0	9.2	5.15	5.45	2.79	3.55	2.0	2.1	4.6	0.2	0.4	2.23	2.49	11.56		
21	2.54	3.56	4.06	9.0	9.2	5.15	5.45	2.79	3.55	2.0	2.1	4.6	0.2	0.4	2.23	2.49	11.56		
25	2.54	3.56	4.06	9.0	9.2	5.15	5.45	2.79	3.55	2.0	2.1	4.6	0.2	0.4	2.23	2.49	11.56		
31	2.54	3.56	4.06	9.0	9.2	5.15	5.45	2.79	3.55	2.0	2.1	4.6	0.2	0.4	2.23	2.49	11.56		
37	2.54	3.56	4.06	9.0	9.2	5.15	5.45	2.79	3.55	2.0	2.1	4.6	0.2	0.4	2.23	2.49	11.56		

NOTES

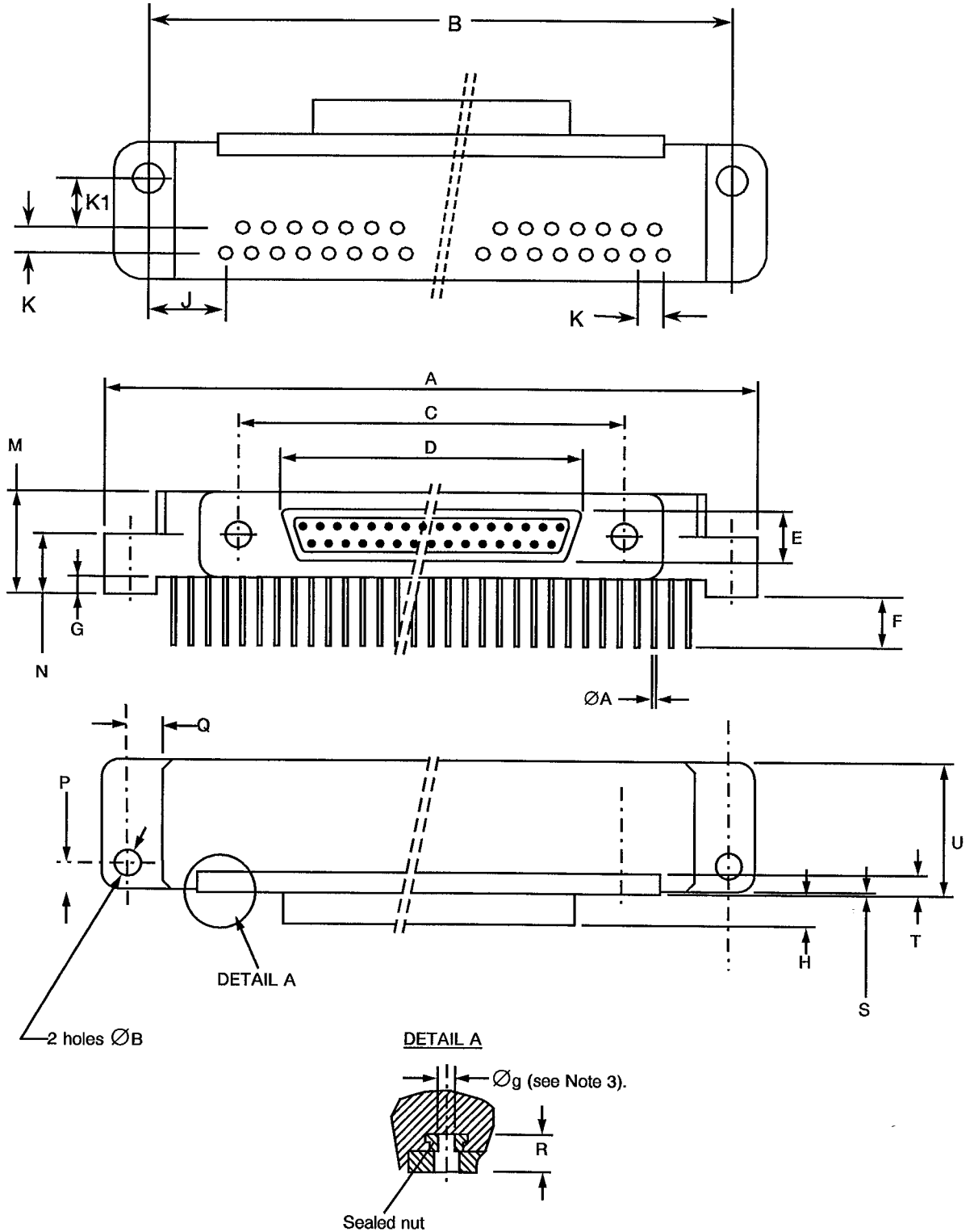
1. All dimensions are in millimetres.
2. For ØA refer to Para. 4.5.3.3 of this specification.
3. Øg: 2-56-UNC-2B.
4. Maximum torque 0.44 Nm.



FIGURE 2 - PHYSICAL DIMENSIONS (CONTINUED)

FIGURE 2.2B - CONNECTORS TYPE -FR136

RECEPTACLE FEMALE CONTACTS





SGC

ESA/SCC Detail Specification

No. 3401/029

PAGE 14

ISSUE 3

FIGURE 2 - PHYSICAL DIMENSIONS (CONTINUED)

FIGURE 2.2B - CONNECTOR TYPE - FR136 (CONTINUED)

RECEPTACLE FEMALE CONTACTS (CONTINUED)

Shell Size	A		B		ØB (4)		C		D		E		F		G		H		J	
	Max.	Min.	Max.	Min.	Max.	Min.	Max.	Min.	Max.	Min.	Max.	Min.	Max.	Min.	Max.	Min.	Max.	Min.	Max.	Typ.
9	35.31	29.03	29.39	2.31	2.59	14.22	14.48	10.16	6.38	4.15	4.85	1.3	1.7	5.05	9.53					
15	39.12	32.84	33.2	2.31	2.59	18.03	18.29	13.97	6.38	4.15	4.85	1.3	1.7	5.05	7.62					
21	42.93	36.65	37.01	2.31	2.59	21.84	22.1	17.78	6.38	4.15	4.85	1.3	1.7	5.05	5.72					
25	45.47	39.19	39.55	2.31	2.59	24.38	24.64	20.32	6.38	4.15	4.85	1.3	1.7	5.05	4.45					
31	51.82	45.54	45.9	2.31	2.59	28.19	28.45	24.13	6.38	4.15	4.85	1.3	1.7	5.05	3.81					
37	59.44	53.16	53.52	2.31	2.59	32.0	32.26	27.94	6.38	4.15	4.85	1.3	1.7	5.05	3.81					

Shell Size	K		K1		M		N		P		Q		R		S		T		U	
	Typ.	Min.	Max.	Min.	Max.	Min.	Max.	Min.	Max.	Min.	Max.	Min.	Max.	Min.	Max.	Min.	Max.	Min.	Max.	Max.
9	2.54	3.56	4.06	9.0	9.2	5.15	5.45	2.79	3.55	2.0	2.1	4.6	0.2	0.4	2.23	2.49	11.56			
15	2.54	3.56	4.06	9.0	9.2	5.15	5.45	2.79	3.55	2.0	2.1	4.6	0.2	0.4	2.23	2.49	11.56			
21	2.54	3.56	4.06	9.0	9.2	5.15	5.45	2.79	3.55	2.0	2.1	4.6	0.2	0.4	2.23	2.49	11.56			
25	2.54	3.56	4.06	9.0	9.2	5.15	5.45	2.79	3.55	2.0	2.1	4.6	0.2	0.4	2.23	2.49	11.56			
31	2.54	3.56	4.06	9.0	9.2	5.15	5.45	2.79	3.55	2.0	2.1	4.6	0.2	0.4	2.23	2.49	11.56			
37	2.54	3.56	4.06	9.0	9.2	5.15	5.45	2.79	3.55	2.0	2.1	4.6	0.2	0.4	2.23	2.49	11.56			

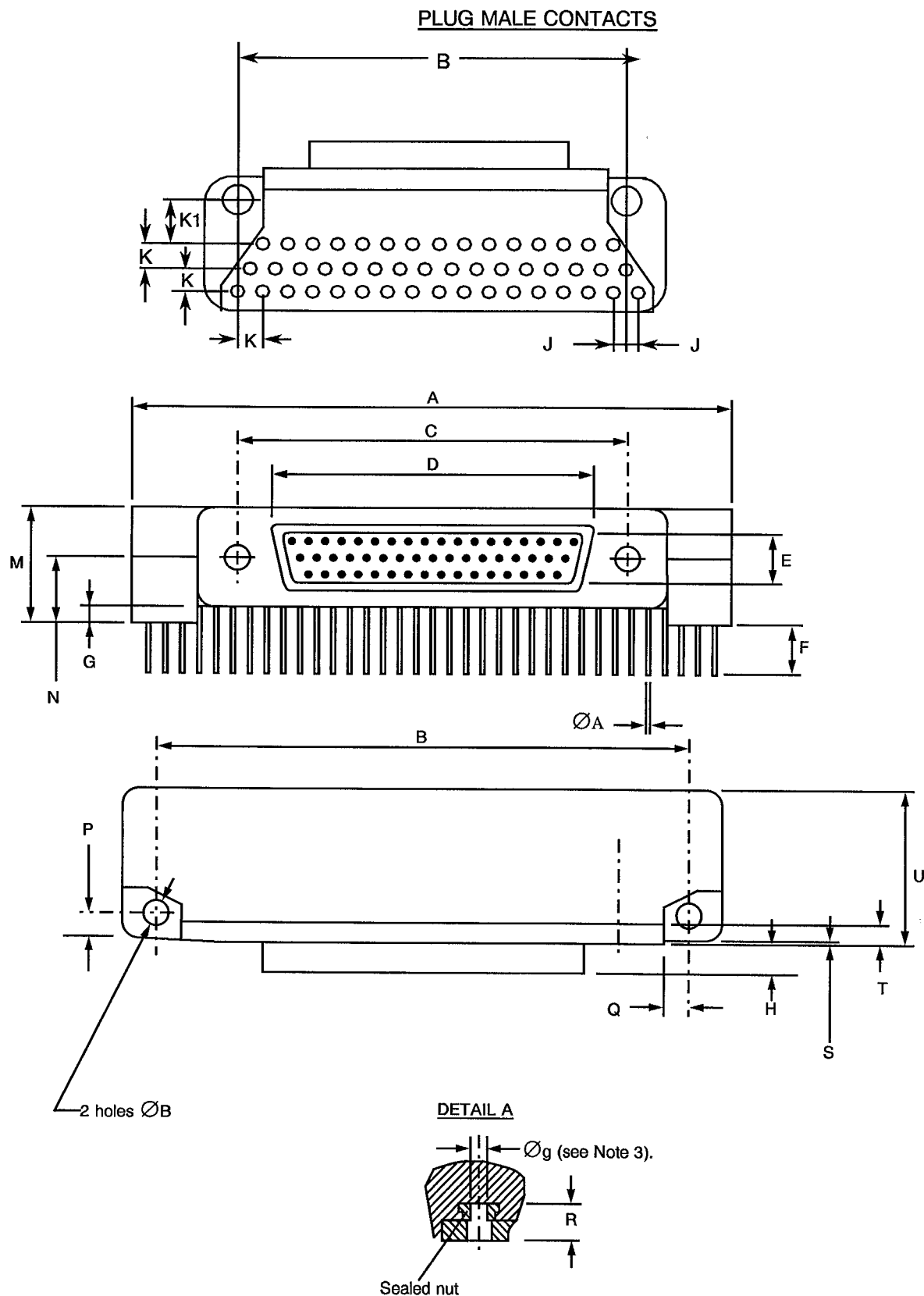
NOTES

1. All dimensions are in millimetres.
2. For ØA refer to Para. 4.5.3.3 of this specification.
3. Øg: 2-56-UNC-2B.
4. Maximum torque 0.44Nm.



FIGURE 2 - PHYSICAL DIMENSIONS (CONTINUED)

FIGURE 2.2C - CONNECTORS TYPE -FR136



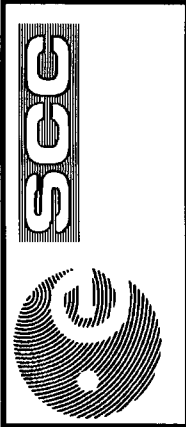


FIGURE 2 - PHYSICAL DIMENSIONS (CONTINUED)

FIGURE 2.2C - CONNECTOR TYPE - FR136 (CONTINUED)

PLUG MALE CONTACTS (CONTINUED)

Shell Size	A	B		ØB (4)		C	D	E	F		G	H	J		
		Min.	Max.	Min.	Max.				Min.	Max.				Min.	Max.
51	47.63	40.46	40.82	2.31	2.59	30.73	30.99	24.97	5.78	4.15	4.85	1.3	1.7	4.72	1.27

Shell Size	K	K1		M		N	P	Q	R	S		T	U						
		Min.	Max.	Min.	Max.					Min.	Max.			Min.	Max.				
51	2.54	3.56	4.06	10.10	10.40	5.81	6.11	2.79	3.55	2.05	2.15	4.5	4.5	0.2	0.4	2.23	2.49	2.49	14.35

NOTES

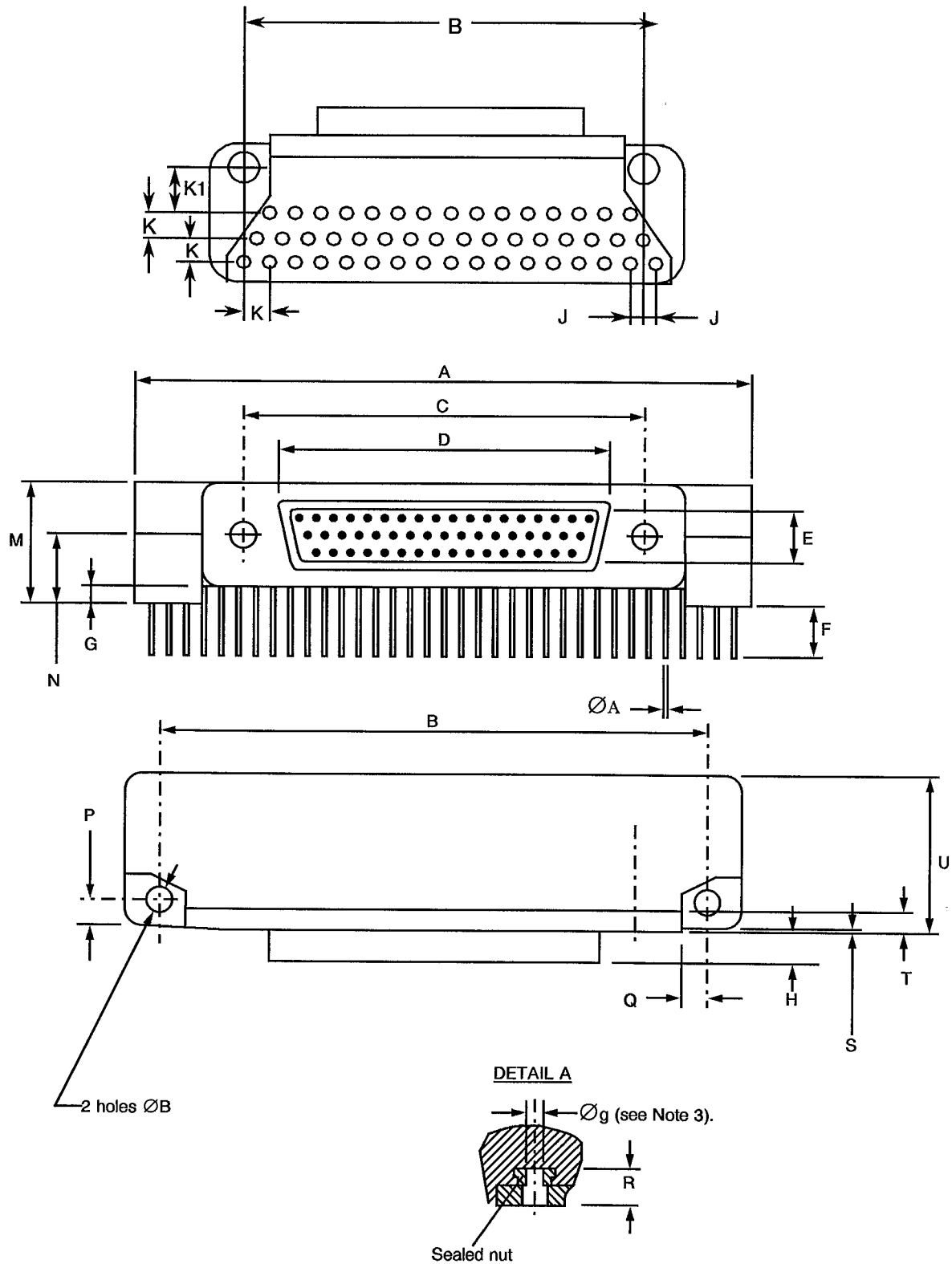
1. All dimensions are in millimetres.
2. For ØA refer to Para. 4.5.3.3 of this specification.
3. Øg: 2-56-UNC-2B.
4. Maximum torque 0.44Nm.



FIGURE 2 - PHYSICAL DIMENSIONS (CONTINUED)

FIGURE 2.2D - CONNECTORS TYPE -FR136

RECEPTACLE FEMALE CONTACTS



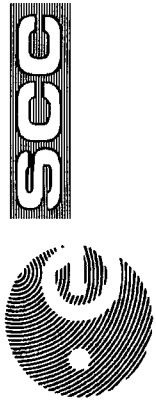


FIGURE 2 - PHYSICAL DIMENSIONS (CONTINUED)

FIGURE 2.2D - CONNECTOR TYPE - FR136 (CONTINUED)

RECEPTACLE FEMALE CONTACTS (CONTINUED)

Shell Size	A	B		ØB (4)		C	D	E	F		G	H	J		
		Min.	Max.	Min.	Max.				Min.	Max.				Min.	Max.
51	47.63	40.46	40.82	2.31	2.59	30.73	30.99	26.67	7.47	4.15	4.85	1.3	1.7	5.05	1.27

Shell Size	K	K1		M	N		P		Q		R	S		T	U		
		Min.	Max.		Min.	Max.	Min.	Max.	Min.	Max.		Min.	Max.			Min.	Max.
51	2.54	3.56	4.06	10.10	10.40	5.81	6.11	2.79	3.55	2.05	2.15	4.5	0.2	0.4	2.23	2.49	14.35

NOTES

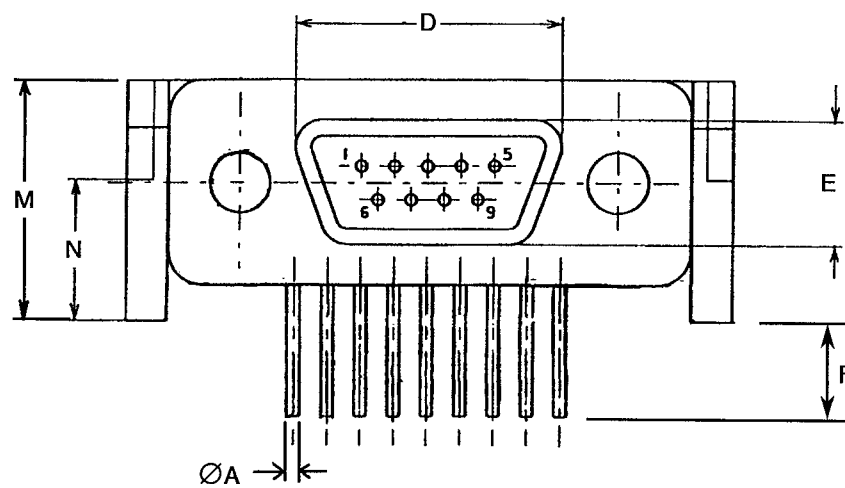
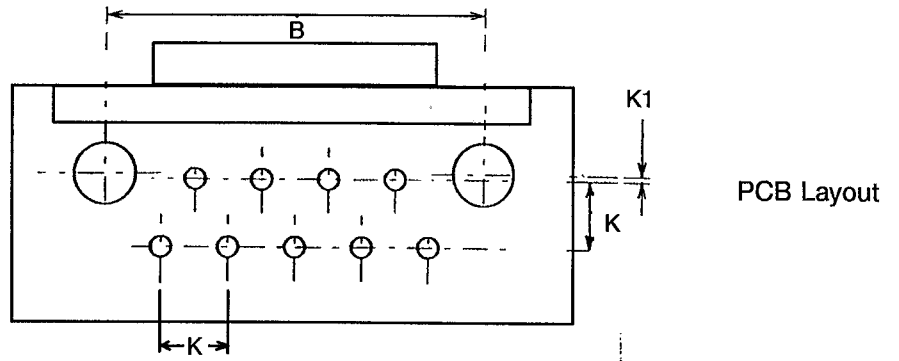
1. All dimensions are in millimetres.
2. For ØA refer to Para. 4.5.3.3 of this specification.
3. Øg: 2-56-UNC-2B.
4. Maximum torque 0.44Nm.



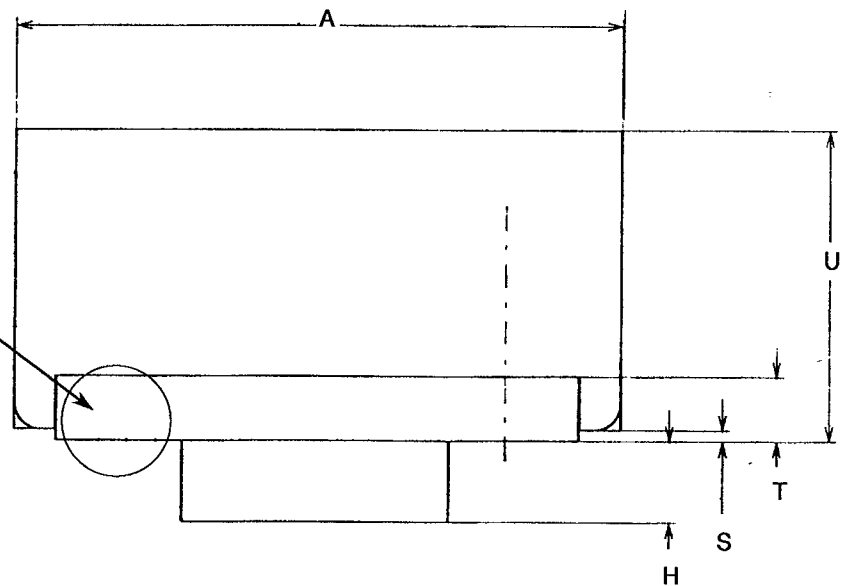
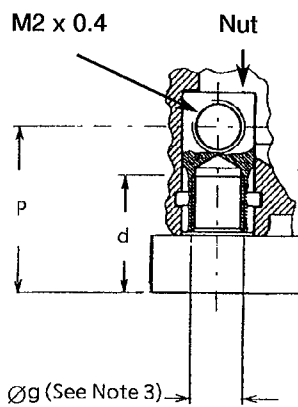
FIGURE 2 - PHYSICAL DIMENSIONS (CONTINUED)

FIGURE 2.2E - CONNECTORS TYPE - FR136A

PLUG MALE CONTACTS



DETAIL A



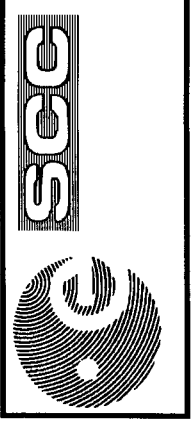


FIGURE 2 - PHYSICAL DIMENSIONS (CONTINUED)

FIGURE 2.2E - CONNECTOR TYPE - FR136A (CONTINUED)

PLUG MALE CONTACTS (CONTINUED)

Shell Size	A	B		d	D	E	E		H	K	K1
	Max.	Min.	Max.	Min.	Max.	Max.	Min.	Max.	Max.	Typ.	
9	23.12	14.22	14.48	4.6	8.46	4.69	3.3	3.7	4.72	2.54	0.2

Shell Size	M		N		P		S		T	U	
	Min.	Max.	Min.	Max.	Min.	Max.	Min.	Max.	Min.	Max.	
9	9.0	9.2	5.15	5.45	6.48	7.24	0.2	0.4	2.23	2.49	11.5

NOTES

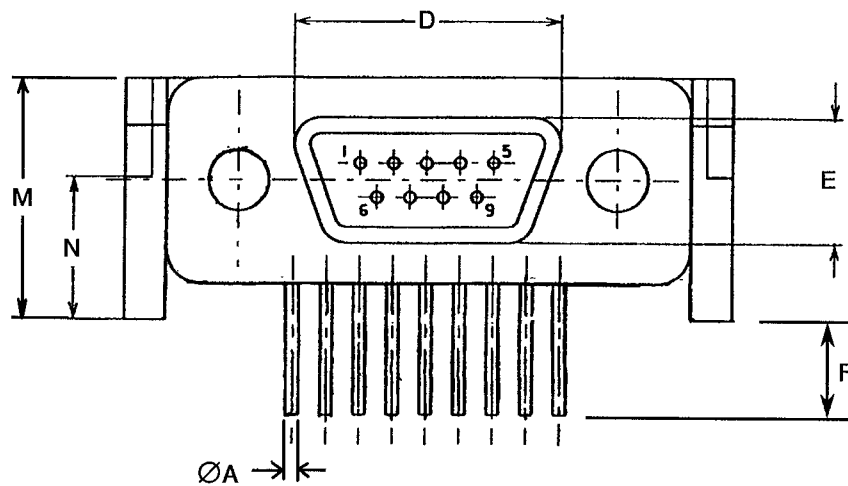
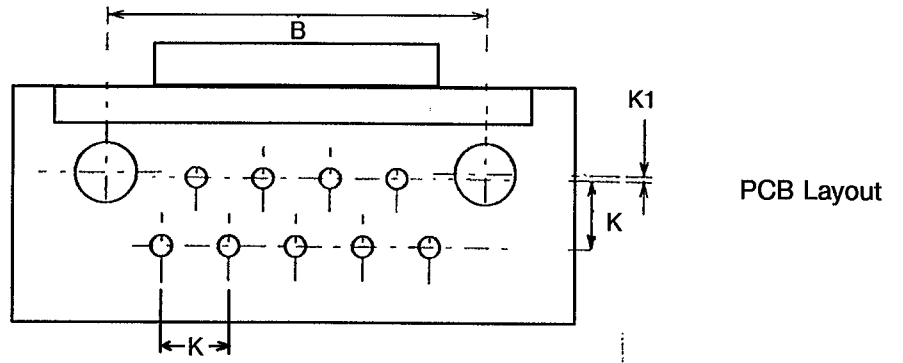
1. All dimensions are in millimetres.
2. For ØA refer to Para. 4.5.3.3 of this specification.
3. Øg: 2-56-UNC-2B.



FIGURE 2 - PHYSICAL DIMENSIONS (CONTINUED)

FIGURE 2.2F - CONNECTORS TYPE - FR136A (CONTINUED)

RECEPTACLE FEMALE CONTACTS



DETAIL A

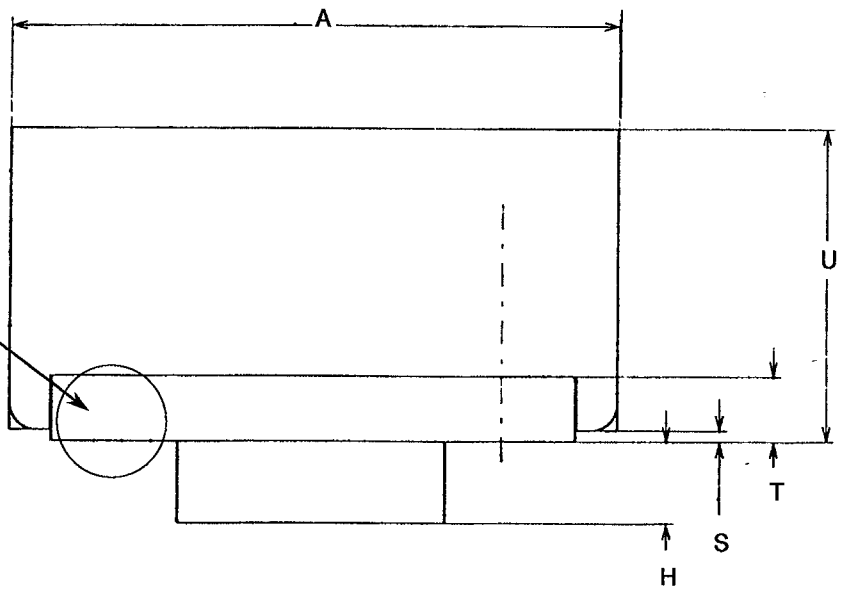
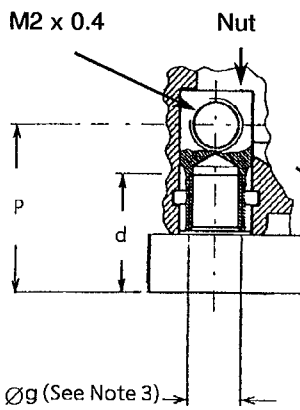




FIGURE 2 - PHYSICAL DIMENSIONS (CONTINUED)

FIGURE 2.2F - CONNECTOR TYPE - FR136A (CONTINUED)

RECEPTACLE FEMALE CONTACTS (CONTINUED)

Shell Size	A	B		d	D	E	E		H	K	K1
	Max.	Min.	Max.	Min.	Max.	Max.	Min.	Max.	Max.	Typ.	
9	23.12	14.22	14.48	4.6	10.16	6.38	3.3	3.7	5.05	2.54	0.2

Shell Size	M		N		P		S		T		U
	Min.	Max.	Min.	Max.	Min.	Max.	Min.	Max.	Min.	Max.	
9	9.0	9.2	5.15	5.45	6.48	7.24	0.2	0.4	2.23	2.49	11.5

NOTES

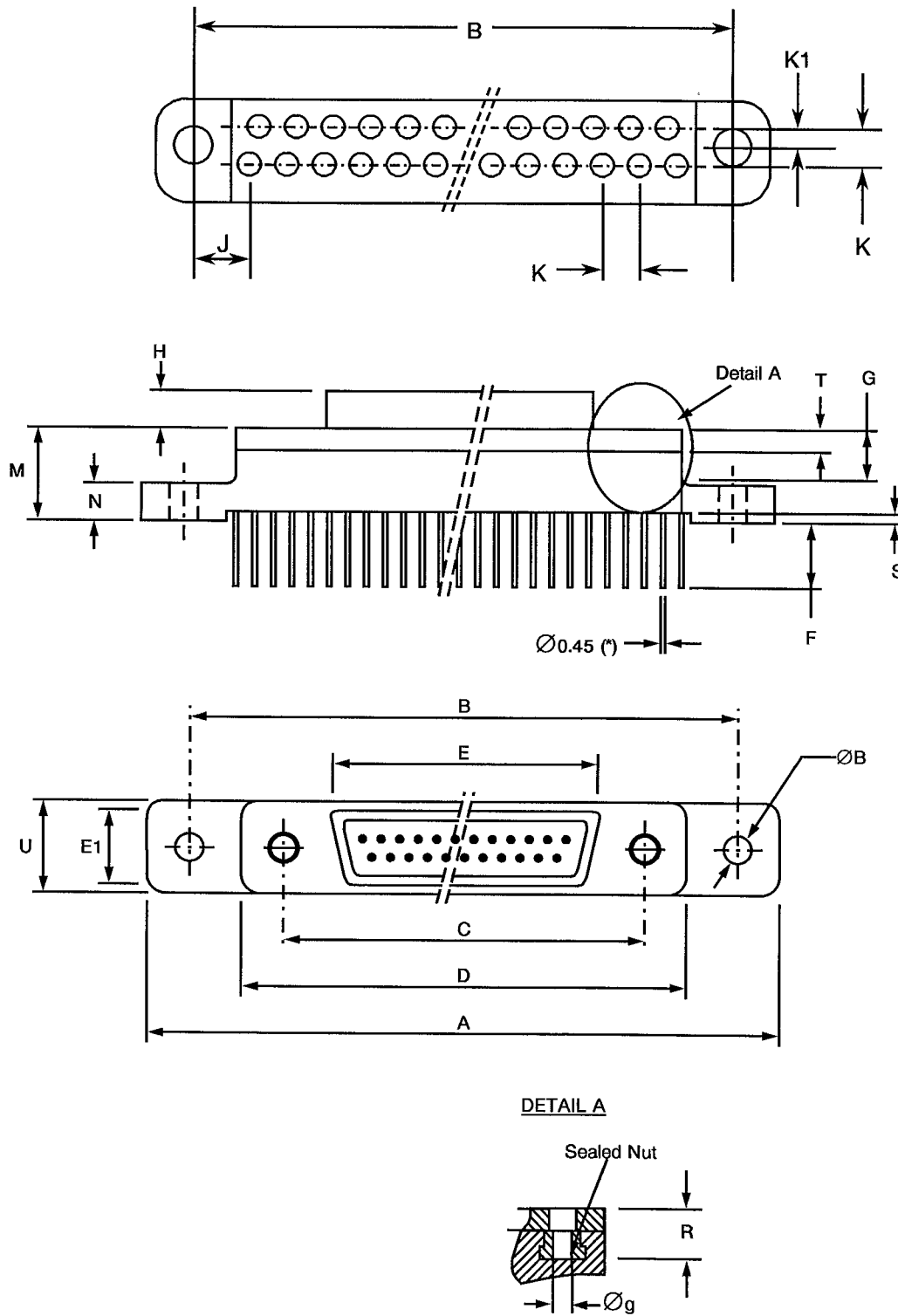
1. All dimensions are in millimetres.
2. For ØA refer to Para. 4.5.3.3 of this specification.
3. Øg: 2-56-UNC-2B.



FIGURE 2 - PHYSICAL DIMENSIONS (CONTINUED)

FIGURE 2.2G - CONNECTORS TYPE -FR139

PLUG MALE CONTACTS





SOCC

ESA/SCC Detail Specification

No. 3401/029

PAGE 24

ISSUE 3

Rev. 'B'

FIGURE 2 - PHYSICAL DIMENSIONS (CONTINUED)

FIGURE 2.2G - CONNECTOR TYPE - FR139 (CONTINUED)

PLUG MALE CONTACTS (CONTINUED)

Shell Size	A		B		ØB (4)		C		D	E	E1	E		G	H	J
	Max.	Min.	Max.	Min.	Max.	Min.	Max.	Min.	Max.	Max.	Max.	Min.	Max.	Min.	Max.	Typ.
9	35.31	29.03	29.39	2.31	2.59	14.22	14.48	19.94	8.46	4.69	4.69	4.15	4.85	4.6	4.72	9.53
15	35.31	29.03	29.39	2.31	2.59	18.03	18.29	23.75	12.27	4.69	4.69	4.15	4.85	4.6	4.72	5.72
21	42.93	36.65	37.01	2.31	2.59	21.84	22.1	27.56	16.08	4.69	4.69	4.15	4.85	4.6	4.72	5.72
25	44.2	37.92	38.28	2.31	2.59	24.38	24.64	30.10	18.62	4.69	4.69	4.15	4.85	4.6	4.72	3.81
31	51.82	45.54	45.9	2.31	2.59	28.19	28.45	33.91	22.43	4.69	4.69	4.15	4.85	4.6	4.72	3.81
37	59.44	53.16	53.52	2.31	2.59	32.0	32.26	37.72	26.24	4.69	4.69	4.15	4.85	4.6	4.72	3.81

Shell Size	K	K1	M		N		R		S		T		U
	Typ.	Typ.	Min.	Max.	Min.	Max.	Min.	Max.	Min.	Max.	Min.	Max.	Max.
9	2.54	1.27	8.62	9.02	4.0	4.2	4.6	4.6	0.9	1.1	2.23	2.49	7.82
15	2.54	1.27	8.62	9.02	4.0	4.2	4.6	4.6	0.9	1.1	2.23	2.49	7.82
21	2.54	1.27	8.62	9.02	4.0	4.2	4.6	4.6	0.9	1.1	2.23	2.49	7.82
25	2.54	1.27	8.62	9.02	4.0	4.2	4.6	4.6	0.9	1.1	2.23	2.49	7.82
31	2.54	1.27	8.62	9.02	4.0	4.2	4.6	4.6	0.9	1.1	2.23	2.49	7.82
37	2.54	1.27	8.62	9.02	4.0	4.2	4.6	4.6	0.9	1.1	2.23	2.49	7.82

NOTES

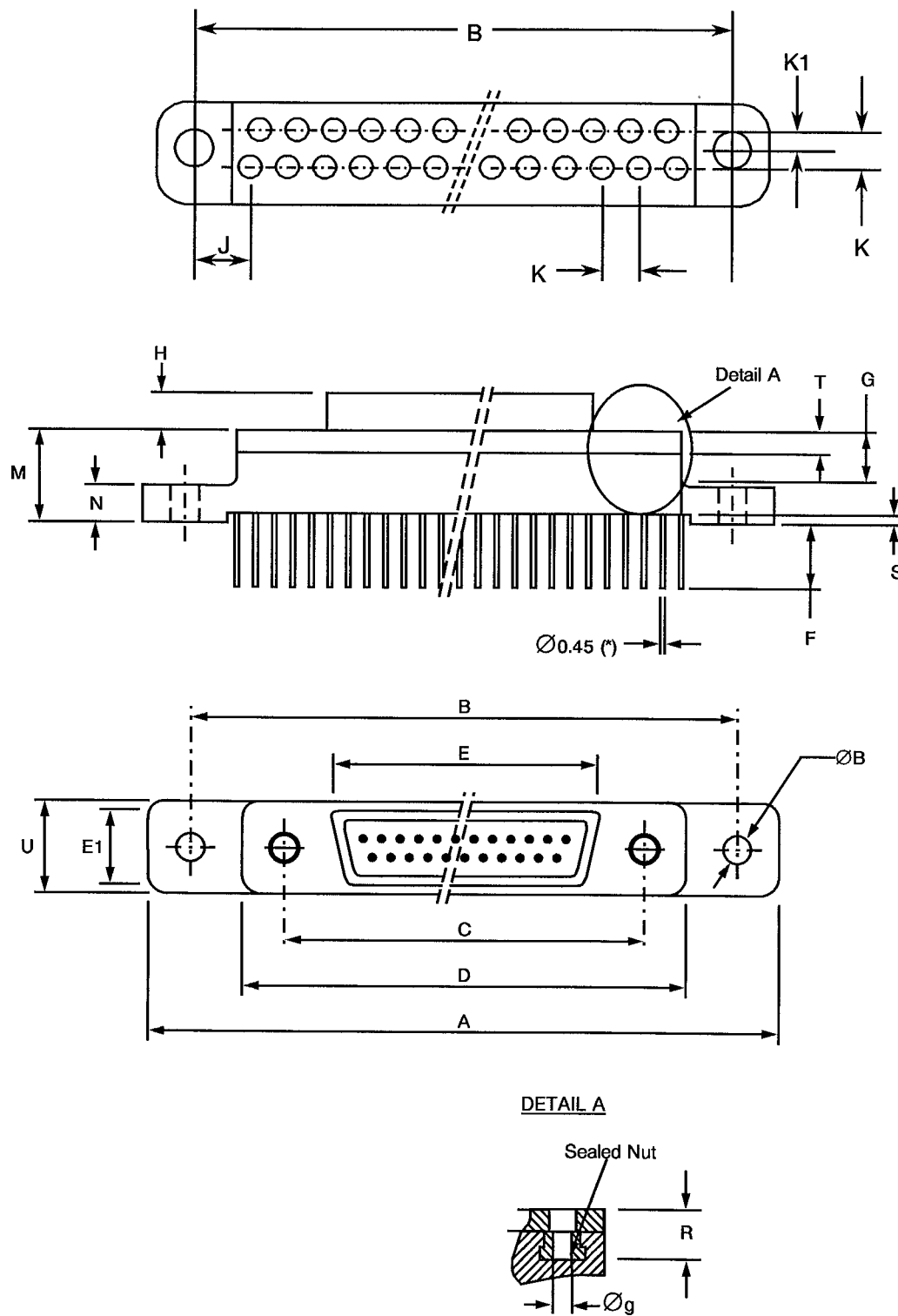
1. All dimensions are in millimetres.
2. For ØA refer to Para. 4.5.3.3 of this specification.
3. Øg: 2-56-UNC-2B.
4. Maximum torque 0.44Nm.



FIGURE 2 - PHYSICAL DIMENSIONS (CONTINUED)

FIGURE 2.2H - CONNECTORS TYPE -FR139

RECEPTACLE FEMALE CONTACTS





SCC

ESA/SCC Detail Specification

No. 3401/029

PAGE 26

Rev. 'B'

ISSUE 3

FIGURE 2 - PHYSICAL DIMENSIONS (CONTINUED)

FIGURE 2.2H - CONNECTOR TYPE - FR139 (CONTINUED)

RECEPTACLE FEMALE CONTACTS (CONTINUED)

Shell Size	A		B		ØB (4)		C		D	E	E1	E		G	H	J	K
	Max.	Min.	Max.	Min.	Max.	Min.	Max.	Min.	Max.	Max.	Max.	Min.	Max.	Min.	Max.	Typ.	Typ.
9	35.31	29.03	29.39	2.31	2.59	14.22	14.48	19.94	10.16	6.38	4.15	4.85	4.6	5.05	9.53	2.54	
15	35.31	29.03	29.39	2.31	2.59	18.03	18.29	23.35	13.97	6.38	4.15	4.85	4.6	5.05	5.72	2.54	
21	42.93	36.65	37.01	2.31	2.59	21.84	22.1	27.56	17.78	6.38	4.15	4.85	4.6	5.05	5.72	2.54	
25	44.2	37.92	38.28	2.31	2.59	24.38	24.64	30.10	20.32	6.38	4.15	4.85	4.6	5.05	3.81	2.54	
31	51.82	45.54	45.9	2.31	2.59	28.19	28.45	33.91	24.13	6.38	4.15	4.85	4.6	5.05	3.81	2.54	
37	59.44	53.16	53.52	2.31	2.59	32.0	32.26	37.72	27.94	6.38	4.15	4.85	4.6	5.05	3.81	2.54	

Shell Size	K1	M		N		R	S		T		U
	Min.	Min.	Max.	Min.	Max.	Min.	Min.	Max.	Min.	Max.	Max.
9	1.27	8.62	9.02	4.0	4.2	4.6	0.9	1.1	2.23	2.49	7.82
15	1.27	8.62	9.02	4.0	4.2	4.6	0.9	1.1	2.23	2.49	7.82
21	1.27	8.62	9.02	4.0	4.2	4.6	0.9	1.1	2.23	2.49	7.82
25	1.27	8.62	9.02	4.0	4.2	4.6	0.9	1.1	2.23	2.49	7.82
31	1.27	8.62	9.02	4.0	4.2	4.6	0.9	1.1	2.23	2.49	7.82
37	1.27	8.62	9.02	4.0	4.2	4.6	0.9	1.1	2.23	2.49	7.82

NOTES

1. All dimensions are in millimetres.
2. For ØA refer to Para. 4.5.3.3 of this specification.
3. Øg: 2-56-UNC-2B.
4. Maximum torque 0.44Nm.



FIGURE 2 - PHYSICAL DIMENSIONS (CONTINUED)

FIGURE 2.3 - CONTACT POSITION

Figure 2.3.1 - Mounting Condition

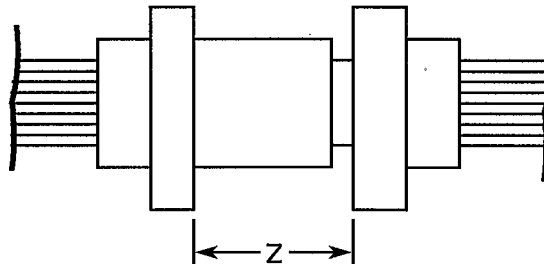


Figure 2.3.2 - Plug Male Contact

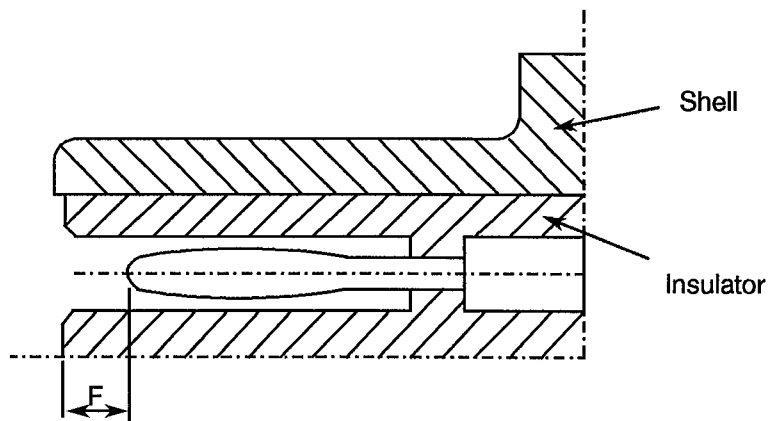
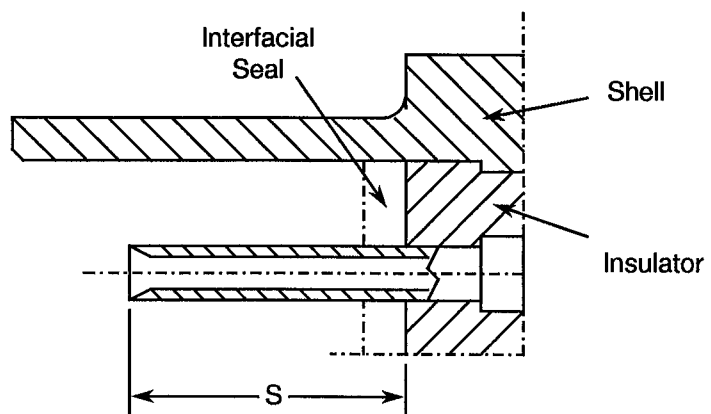


Figure 2.3.3 - Receptacle Female Contact



F		S		Z
Min.	Max.	Min.	Max.	Max.
0.25	0.91	3.30	3.66	5.49

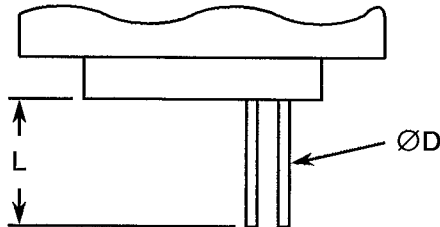
NOTES

1. All dimensions are in millimetres.



FIGURE 2 - PHYSICAL DIMENSIONS (CONTINUED)

FIGURE 2-4 - UNINSULATED SOLID WIRES

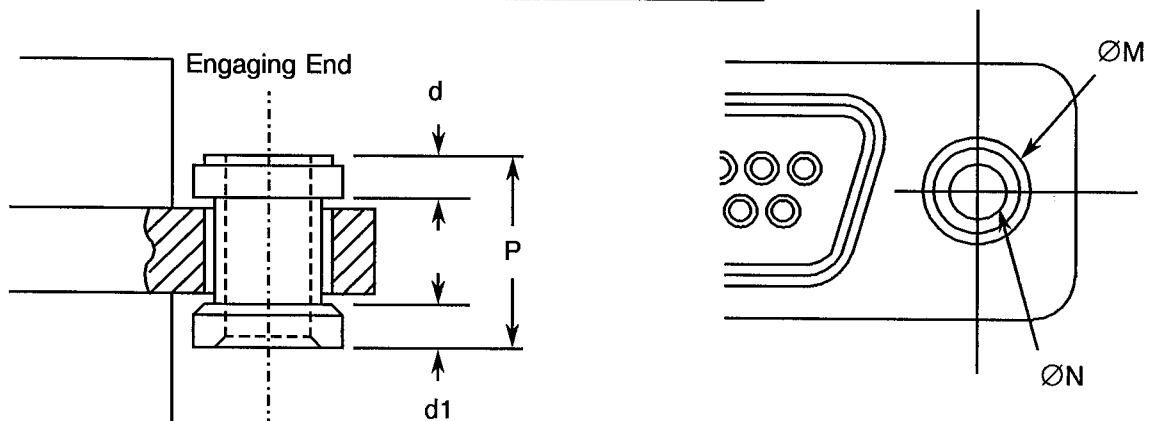


Wire Size (AWG)	25
Max. Diameter 'D' (mm)	0.46
Min. Diameter 'D' (mm)	0.45
Min. Gold Plating Thickness (µm)	0.5
Max. Weight (g/m)	1.6
Min. Length 'L'	See Para. 4.5.3.3

FIGURE 2-5 INSULATED WIRES

Wire Size AWG		26	28
Conductor Characteristics	Maximum diameter (mm)	0.50	0.42
	Nominal cross-section (mm ²)	0.14	0.10
Wire Characteristics	Maximum diameter (mm)	0.89	0.82
	Maximum weight (g/m)	2.3	1.8
	Colour	Natural	Natural
	Minimum Length	See Para. 4.5.3.3	

FIGURE 2-6 - FLOATING MOUNT



P Max.	d	d1	ØM Max.	ØN Min.
4.70	1.0	0.8	4.0	2.26

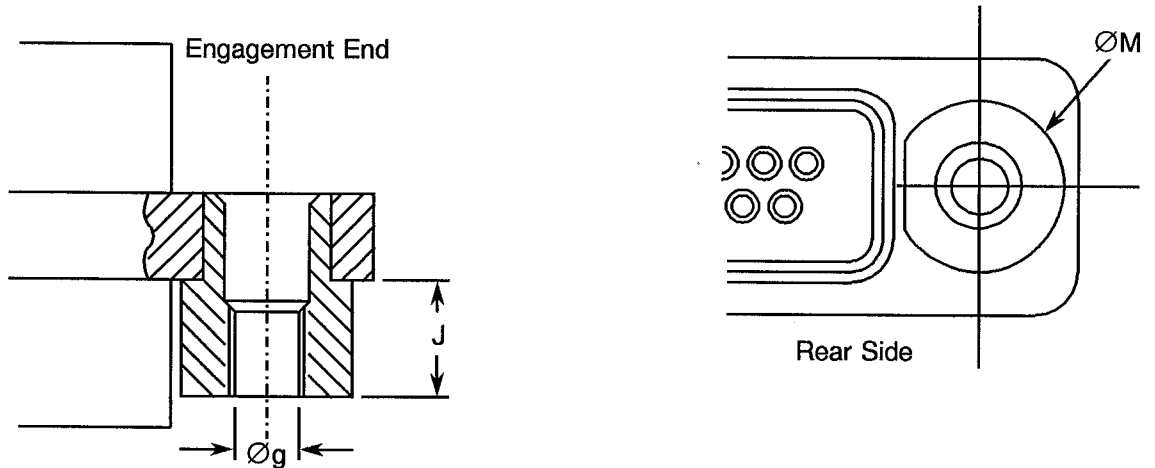
NOTES

1. All dimensions are in millimetres.
2. Total Lateral Float 0.4 typical.
3. Total Axial Float 0.4 typical.



FIGURE 2 - PHYSICAL DIMENSIONS (CONTINUED)

FIGURE 2.7 - CAPTIVE NUT



$\varnothing g$	J Max.	$\varnothing M$ Max.
Note 2	2.60	5.1

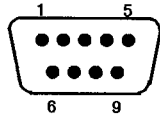
NOTES

1. All dimensions are in millimetres.
2. $\varnothing g$: 2-56 UNC 2B, Maximum Torque 0.44Nm.

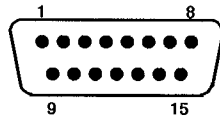


FIGURE 3 - CONTACT ARRANGEMENTS

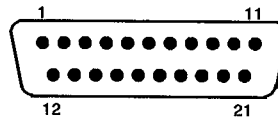
FRONT VIEW OF MALE INSERT - USE MIRROR VIEW FOR FEMALE INSERT



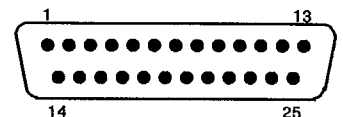
9 CONTACTS



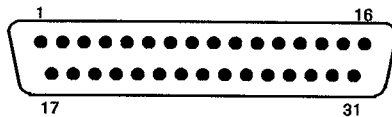
15 CONTACTS



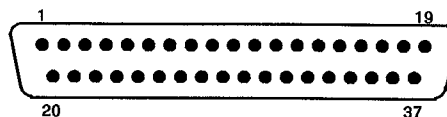
21 CONTACTS



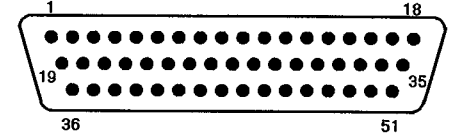
25 CONTACTS



31 CONTACTS



37 CONTACTS

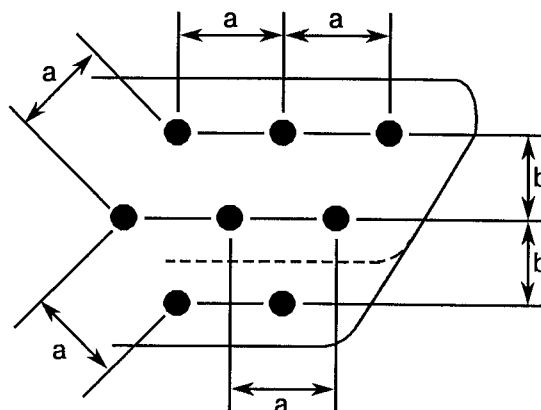


51 CONTACTS

NOTES

1. Only the outside contact cavities on each row are identified in the drawing, the remainder follow sequentially. Contact numbers are shown outside the insert for readability.

Contact Centres



NOTES

1. a = Distance between contact centres: 1.27mm typical.
2. b = Distance between rows: 1.09mm typical.

**4. REQUIREMENTS****4.1 GENERAL**

The complete requirements for procurement of the connectors specified herein are stated in this specification and ESA/SCC Generic Specification No. 3401. Deviations from the Generic Specification, applicable to this specification only, are listed in Para. 4.2.

Deviations from the applicable Generic Specification and this Detail Specification, formally agreed with specific Manufacturers on the basis that the alternative requirements are equivalent to the ESA/SCC requirements and do not affect the components' reliability, are listed in the appendices attached to this specification.

4.2 DEVIATIONS FROM GENERIC SPECIFICATION**4.2.1 Deviations from Special In-process Controls**

Para. 9.15, Joint Strength: The contacts shall be crimped to insulated stranded wire AWG26 and AWG28, and to uninsulated solid wire AWG25. The value of failure shall be recorded together with the information as to whether the failure was "pull-out", "break in crimp" or "break in wire". The minimum tensile strength shall be as follows:

WIRE	MALE AND FEMALE CONTACTS		
	AWG26	AWG28	AWG25 - Solid Uninsulated
Tensile Strength (N)	22	13	22

4.2.2 Deviations from Final Production Tests (Chart II)

(a) Para. 9.4, Contact Capability: This test shall be performed on the male contacts. For details see Para. 4.3.3 of this specification.

(b) Para. 9.5, Magnetism Level: Not applicable.

4.2.3 Deviations from Burn-in and Electrical Measurements (Chart III)

None.

4.2.4 Deviations from Qualification Tests (Chart IV)

(a) Para. 9.15, Joint Strength: Not applicable.

(b) Para. 9.17, Contact Retention (In insert): Not applicable with male contact.

(c) Para. 9.27, Maintenance Ageing: Not applicable.

(d) Para. 9.29, Oversize Pin Exclusion: Not applicable.

(e) Para. 9.30, Probe Damage: Not applicable.

4.2.5 Deviations from Lot Acceptance Tests (Chart V)

(a) Para. 9.15, Joint Strength: Not applicable.

(b) Para. 9.17, Contact Retention (In insert): Not applicable with male contact.

(c) Para. 9.27, Maintenance Ageing: Not applicable.

(d) Para. 9.29, Oversize Pin Exclusion: Not applicable.

(e) Para. 9.30, Probe Damage: Not applicable.



4.3 MECHANICAL REQUIREMENTS

4.3.1 Dimension Check

The dimensions of the connectors specified herein shall be verified in accordance with the requirements set out in Para. 9.6 of ESA/SCC Generic Specification No. 3401 and shall conform to those shown in Figure 2 of this specification. Only the underlined dimensions shall be checked during procurement.

4.3.2 Weight

The maximum weight of the connectors specified herein shall be calculated on the basis of, and be in accordance with the values given in Table 1(a) and in Figures 2-4 and 2-5 of this specification.

4.3.3 Contact Capability

For the purpose of this test, the pick-up and drop weights shall be as follows.

MEASUREMENTS	PICK-UP WEIGHT	DROP WEIGHT
Weight (g)	14	170
Inner Gauge Diameter (mm) (1)	0.582 - 0.587	0.559 - 0.564
Insertion Depth (mm)	1.5	1.5

NOTES

1. See Figure 4 for ØA.

4.3.4 Contact Retention (In insert)

Contact retention within the insert shall be 22.25 Newtons. There shall be no displacement of the contact. Not applicable to male contacts.

4.3.5 Mating and Unmating Forces

The forces applied for the mating and unmating of the connectors shall conform to the values specified in Table 1(a).

4.3.6 Insert Retention (In shell)

Connector inserts shall withstand a pressure of 34.4N/cm² applied from the mating side to the rear side.

4.3.7 Jackscrew Retention

Not applicable.

4.3.8 Contact Insertion and Withdrawal Forces

Not applicable.

4.3.9 Engagement and Separation Forces (Male Contacts)

The contact engagement and separation forces of the male contacts shall be tested to a depth of 1.5mm with the applicable test gauge fixtures specified in Figure 4 of this specification, and shall not exceed the values of the table hereunder.

MEASUREMENTS	INNER DIAMETER (mm)		SEPARATION FORCE Min. (N)	ENGAGEMENT FORCE Max. (N)
	Min.	Max.		
Max. Gauge Fixture	0.559	0.564	-	1.667
Min. Gauge Fixture	0.582	0.587	0.137	-

**4.3.10 Oversize Pin Exclusion**

Not applicable.

4.3.11 Probe Damage

Not applicable.

4.3.12 Solderability

Not applicable.

4.4 MATERIALS AND FINISHES

The materials and finishes shall be as specified herein. Where a definite material is not specified, a material which will enable the connectors specified herein to meet the performance requirements of this specification shall be used. Acceptance or approval of any constituent material does not guarantee acceptance of the finished product.

4.4.1 Shells

Shells shall be made of aluminium alloy. The plating shall be 25.4µm minimum of electroless nickel (Variant 01) or with a minimum thickness of 2.54µm of gold over an electroless nickel underlay (Variant 02).

4.4.2 Inserts

Inserts shall be made of glass fibre-filled diallyphtalate resin or suitable thermoplastic material.

4.4.3 Contacts**4.4.3.1 Female Contacts**

The contact body shall be made of copper alloy with an underplate of 1.0µm minimum of copper to MIL-C-14550, gold plated with 1.27µm minimum of gold, Type 2, Grade C of MIL-G-45204. Measurement of thickness shall be performed at a distance of 1.5mm from the engagement end.

4.4.3.2 Male Contacts

The contact body and the bundle shall be made of copper alloy with an underplate of 1.0µm minimum of copper to MIL-C-14550, gold plated with 1.27µm minimum of gold, Type 2, Grade C of MIL-G-45204. Measurement of thickness shall be performed at a distance of 1.5mm from the engagement end.

4.4.4 Seals Interfacial

Interfacial seals shall be made of silicon base rubber.

4.4.5 Insulated Wires

Wire materials and finishes shall be in accordance with the requirements specified in Para. 4.4 of ESA/SCC Detail Specification No. 3901/013.

4.4.6 Uninsulated Solid Wire

Uninsulated solid wires shall be made of copper alloy in accordance with Type 'S' as specified in QQ-W-343. They shall be gold-plated in accordance with Class ØØ, Grade C or D, as specified in MIL-G-45204.

4.4.7 Rear Potting

Rear potting shall be made of epoxy resin. For connectors Type FR136, Type FR136A and Type FR139, the rear container shall be made from glass-fibre filled diallyphtalate resin.



4.5 MARKING

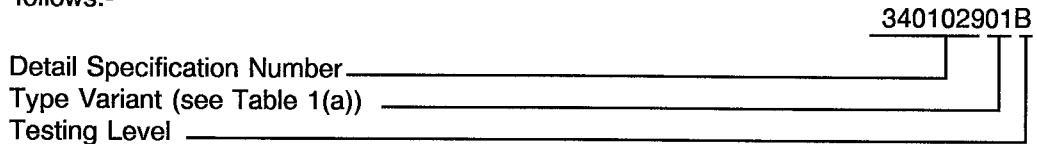
4.5.1 General

The marking of all components delivered to this specification shall be in accordance with the requirements of ESA/SCC Basic Specification No. 21700 and the following paragraphs. Each component shall be marked in respect of:-

- (a) The SCC Component Number.
- (b) Characteristics.
- (c) Traceability Information.

4.5.2 The SCC Component Number

Each component shall bear the SCC Component Number which shall be constituted and marked as follows:-



N.B.

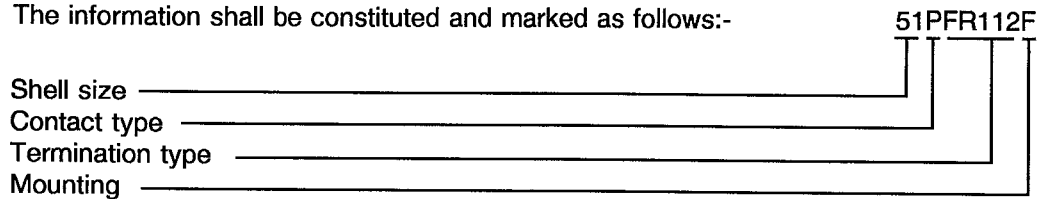
Marking of the Type Variant is mandatory. No further reference to type variant is made in this specification.

4.5.3 Characteristics

The characteristics to be marked in the following order of precedence are:-

- (a) Shell Size.
- (b) Contact Type.
- (c) Termination Type.
- (d) Mounting.

The information shall be constituted and marked as follows:-



4.5.3.1 Shell Size

Shell size shall be designated by the number of contacts.

Specified numbers are: 9, 15, 21, 25, 31, 37 and 51.

4.5.3.2 Contact Type

Contact types shall be indicated by the following code letters.

Code Letter	Contact Type
P	Male
S	Female



4.5.3.3 Termination Type

Termination codes define the length of insulate wire or uninsulated wire according to Figures 2-1 to 2-5 as follows:-

CODE	TYPE	MIN. LENGTH (mm)
FR112	AWG 26 Wire	508
FR113	AWG 26 Wire	914
FR114	AWG 28 Wire	508
FR115	AWG 28 Wire	914
FR116	UNINSULATED WIRE	25.4
FR123	AWG 26 Wire	4000
FR136 FR136A	90° mounting on P.C.B.	-
FR139	Straight mounting on P.C.B.	-

4.5.3.4 Mounting

The letter "E" indicates a captive nut.

The letter "F" shall indicate a floating mount.

If the shell has fixed mounting holes, these letters shall be omitted.

4.5.4 Traceability Information

Traceability information shall be marked in accordance with the requirements of ESA/SCC Basic Specification No. 21700.

4.6 ELECTRICAL MEASUREMENTS

4.6.1 Electrical Measurements at Room Temperature

The parameters to be measured in respect of electrical characteristics are scheduled in Table 2. Unless otherwise specified, the measurements shall be performed at $T_{amb} = +22 \pm 3$ °C.

4.6.2 Electrical Measurements at High and Low Temperatures

Not applicable.

4.6.3 Circuits for Electrical Measurements (Figure 4)

Not applicable.

4.7 BURN-IN AND ELECTRICAL MEASUREMENTS (TABLES 4 AND 5)

Not applicable.

**TABLE 2 - ELECTRICAL MEASUREMENTS AT ROOM TEMPERATURE**

No.	Characteristic	Symbol	ESA/SCC 3401 Test Method	Test Condition	Limits		Unit
					Min.	Max.	
1	Insulation Resistance	Ri	Para. 9.1.1.1	Para. 9.1.1.1	5 000	-	MΩ
2	Voltage Proof Leakage Current	I _L	Para. 9.1.1.2	600 Vrms	-	2.0	mA
3	Mated Shell Conductivity (Voltage Drop) (1)	Vd	Para. 9.1.1.4	Para. 9.1.1.4	Not applicable		mV
4	Contact Resistance (Low Level Current)	Rcl max.	Para. 9.1.1.3	Para. 9.1.1.3	-	6.0	mΩ
5	Contact Resistance (Rated Current)	Rcr max.	Para. 9.1.1.3	Table 1(b)	-	5.0	mΩ

NOTES

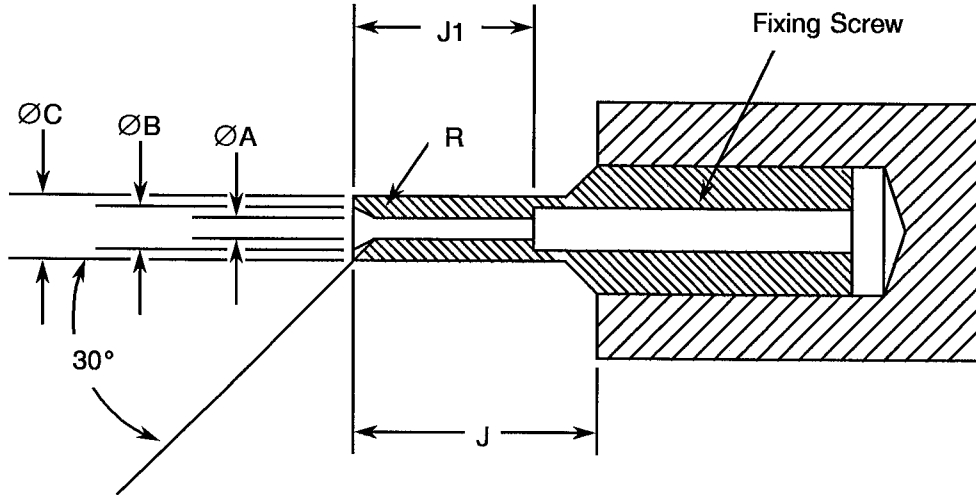
1. Applicable to mated connectors with grounding option.

TABLES 3, 4 AND 5

Not applicable



FIGURE 4 - GAUGE FIXTURE



MAXIMUM GAUGE

WEIGHT (g) 170			REMARKS
	MIN.	MAX.	
ØA	0.559	0.564	-
ØB	0.749	0.775	-
ØC	0.813	0.825	-
J	4.0	-	-
J1	3.13	3.23	-
R	0.381	0.483	Note 1

MINIMUM GAUGE

WEIGHT (g) 14			REMARKS
	MIN.	MAX.	
ØA	0.582	0.587	-
ØB	0.749	0.775	-
ØC	0.813	0.825	-
J	4.0	-	-
J1	3.13	3.23	-
R	0.381	0.483	Note 1

NOTES

1. Radius 'R', must be tangent to entry chamfer and ØA.
2. ØA and entry chamfer must be polished to $\sqrt{N8}$.



- 4.8 ENVIRONMENTAL AND ENDURANCE TESTS (CHARTS IV AND V OF ESA/SCC GENERIC SPECIFICATION NO. 3401)
- 4.8.1 Measurements and Inspections on Completion of Environmental Tests
The parameters to be measured and inspections to be performed on completion of environmental testing shall be those specified in Table 6. Unless otherwise specified, these measurements shall be performed at $T_{amb} = +22 \pm 3 \text{ }^\circ\text{C}$.
- 4.8.2 Measurements and Inspections at Intermediate Points during Endurance Tests
Not applicable.
- 4.8.3 Measurement and Inspections on Completion of Endurance Tests
The parameters to be measured and inspections to be performed on completion of endurance testing shall be those specified in Table 6. Unless otherwise specified, these measurements shall be performed at $T_{amb} = +22 \pm 3 \text{ }^\circ\text{C}$.
- 4.8.4 Conditions for Operating Life Tests (Part of Endurance Testing)
Not applicable.
- 4.8.5 Electrical Circuits for Operating Life Tests (Figure 5)
Not applicable.
- 4.8.6 Conditions for High Temperature Storage Test (Part of Endurance Testing)
The requirements for the high temperature storage test are specified in Section 9 of ESA/SCC Generic Specification No. 3401. The temperature to be applied shall be the maximum storage temperature specified in Table 1(b) of this specification.



TABLE 6 - MEASUREMENTS AND INSPECTIONS ON COMPLETION OF ENVIRONMENTAL AND ENDURANCE TESTING

No.	ESA/SCC GENERIC SPEC. NO. 3401		MEASUREMENTS AND INSPECTIONS		SYMBOL	LIMITS		UNIT
	ENVIRONMENTAL AND ENDURANCE TESTS (1)	TEST METHOD AND CONDITIONS	IDENTIFICATION	CONDITIONS		MIN.	MAX.	
01	Seal Test	Para. 9.9	ESA/SCC 3401 Para. 9.9	-	-	Not applicable		-
02	Wiring	Para. 9.10 and Table 1(a) of this spec.	Low Level Contact Resistance	Table 2 Item 4	Rcl	Table 2, Item 4		-
03	Vibration	Para. 9.11	Initial Measurements Coupling screw(s) Unlocking Torque Final Measurements Full Engagement Coupling screw(s) Unlocking Torque Drift Visual Examination	-	- $\Delta T_{qe}/T_{qe}$	Record Values - - -25 +25	- - %	
04	Shock or Bump	Para. 9.12	Full Engagement Visual Examination	-	-	-	-	-
05	Climatic Sequence	Para. 9.13	Dry Heat Insulation Resistance Low Air Pressure Voltage Proof Leakage Current Damp Heat Insulation Resistance Final Measurements External Visual Inspection Insulation Resistance Voltage Proof Leakage Current	At High Temperature Table 2, Item 1 Figure 1 Immediately after test Table 2, Item 1 After 1-24 hrs Recovery ESA/SCC 3401 Para. 9.7 Table 2, Item 1 Table 2, Item 2	Ri I _L Ri Ri I _L	1000 - ESA/SCC 3401 9.13.5 100 - ESA/SCC 3401 Para. 9.7 Table 2, Item 1 Table 2, Item 2	MΩ MΩ	
06	Plating Thickness	Para. 9.14	Thickness	-	-	Para. 4.4.3 of this spec.		-
07	Joint Strength (N/A to solder contacts)	Para. 9.15	ESA/SCC 3401 Para. 9.15	-	-	Not applicable		-
08	Rapid Change of Temperature	Para. 9.16	Visual Examination Insulation Resistance Voltage Proof Leakage Current	- Table 2, Item 1 Table 2, Item 2	- Ri I _L	- - Table 2, Item 1 Table 2, Item 2	- -	
09	Contact Retention (In Insert)	Para. 9.17 & Para. 4.3.4 of this spec.	Contact Displacement	-	-	ESA/SCC 3401 Para. 9.17		-
010	Endurance	Para. 9.18	Initial Measurements Mating/Unmating Forces Low Level Contact Resistance Mated Shell Conductivity Final Measurements Visual Examination Mating/Unmating Forces Low Level Contact Drift Resistance Mated Shell Conductivity Insulation Resistance Voltage Proof Leakage Current	 Table 2, Item 4 Table 2, Item 3 - Table 2, Item 4 Table 2, Item 5 Table 2, Item 3 Table 2, Item 1 Table 2, Item 2	F Rcl Vd - F ΔRcl Vd Ri I _L	Para. 4.3.5 of this spec. Record Values Not applicable - - Para. 4.3.5 of this spec. - 3.0 Not applicable Table 2, Item 1 Table 2, Item 2	- mΩ	

NOTES

1. The tests in this table refer to either Chart IV or V and shall be used as applicable.



TABLE 6 - MEASUREMENTS AND INSPECTIONS ON COMPLETION OF ENVIRONMENTAL AND ENDURANCE TESTING (CONTINUED)

No.	ESA/SCC GENERIC SPEC. NO. 3401		MEASUREMENTS AND INSPECTIONS		SYMBOL	LIMITS		UNIT
	ENVIRONMENTAL AND ENDURANCE TESTS (1)	TEST METHOD AND CONDITIONS	IDENTIFICATION	CONDITIONS		MIN.	MAX.	
11	Permanence of Marking	Para. 9.19	-	-	-	-	-	-
12	Mating/Unmating Forces	Para. 9.20	Force	-	F	Para. 4.3.5 of this spec.		-
13	High Temperature Storage	Para. 9.21	Initial Measurements Low Level Contact Resistance Mated Shell Conductivity Final Measurements Visual Examination Mating/Unmating Forces Low Level Contact Resistance Drift Rated Current Contact Resis. Mated Shell Conductivity Insulation Resistance Voltage Proof Leakage Current Contact Retention (In insert)	Table 2 Item 4 - - Table 2 Item 4 Table 2 Item 5 Table 2 Item 3 Table 2 Item 1 Table 2 Item 2 Para. 4.3.4 of this spec.	Rcl Vd - F ΔRcl Rcr Vd Ri IL	Record Values Not applicable - - Para. 4.3.5 of this spec. - 3.0 Table 2, Item 5 Not applicable Table 2, Item 1 Table 2, Item 2 ESA/SCC 3401 Para. 9.17	mΩ	
14	Corrosion	Para. 9.22	Visual Examination	-	-	-	-	-
15	Insert Retention (In Shell)	Para. 9.23 & Para. 4.3.6 of this spec.	Visual Examination	-	-	Para. 4.3.6 of this spec.		-
16	Jackscrew Retention	Para. 9.24 and Para. 4.2.7 of this spec.	Visual Examination	-	-	Not applicable		-
17	High Temperature Measurements	Para. 9.25	Insulation Resistance	Table 2 Item 1	Ri	5000	-	MΩ
18	Overload Test	Para. 9.26	Internal Temperature Rated Current Contact Resis. Mated Shell Conductivity Insulation Resistance Voltage Proof Leakage Current	- Table 2 Item 5 Table 2 Item 3 Table 2 Item 1 Table 2 Item 2	T Rcr Vd Ri IL	- +100 Table 2, Item 5 Not applicable Table 2, Item 1 Table 2, Item 2	°C	
19	Maintenance Ageing	Para. 9.27 & Para. 4.2.4 of this spec.	Visual Examination Contact Retention (In insert)	Para. 4.3.4 of this spec.	-	Not applicable		-
20	Engage/Separation Forces	Para. 9.28 & Para. 4.3.9 of this spec.	Force	-	F	Para. 4.3.9 of this spec.		-
21	Oversize Pin Exclusion	Para. 9.29 and Para. 4.3.10 of this spec.	-	-	-	Not applicable		-
22	Probe Damage	Para. 9.30 and Para. 4.3.11 of this spec.	Contact Separation Force	-	F	Not applicable		-
23	Solderability	Para. 9.31 & Para. 4.3.12 of this spec.	-	-	-	Not applicable		-

NOTES

1. The tests in this table refer to either Chart IV or V and shall be used as applicable.



**european space agency
agence spatiale européenne**

Pages 1 to 28

**CONNECTORS, ELECTRICAL, SINGLE-IN-LINE,
MICROMINIATURE,
BASED ON TYPE MTB 1**

ESA/SCC Detail Specification No. 3401/031



**space components
coordination group**

Issue/Rev.	Date	Approved by	
		SCCG Chairman	ESA Director General or his Deputy
Issue 2	September 2002		



DOCUMENTATION CHANGE NOTICE

Rev. Letter	Rev. Date	Reference	CHANGE Item	Approved DCR No.
		This Issue supersedes Issue 1 and incorporates all modifications defined in Revisions 'A', 'B', 'C' and 'D' to Issue 1 and the changes agreed in the following DCRs:-		
		Cover page		None
		DCN		None
		Para. 1.1	: Second document deleted	221664
		Para. 1.2	: Title amended and text rearranged and amended	221664
		Para. 1.3	: In the text, Table reference amended to "1(d)"	221664
		Para. 2	: Items (b), (e) and (f) deleted, Item (c) renumbered as (b), Item (g) renumbered as (c) and new Item (e) added	221664
		Table 1(a)	: New Table added	221664
		Table 1(b)	: New Table added	221664
		Table 1(c)	: New Table added	221664/ 23960
		Table 1	: Renumbered as Table 1(d) and expanded	221664
		Figure 1	: Existing Figure amended and Title added	221664
		Figure 1(b)	: New Figure added	221664
		Figure 2-1	: Split into separate drawings for Plug and Receptacle	221664
		Figure 2-3	: Minimum length paragraph reference amended	23960
		Figure 2-4	: New Figure added	221664
		Figure 2-5	: New Figure added	221664
		Para. 4.2.1	: Deviation added	221664
		Para. 4.2.2	: Existing text deleted and deviations (a) to (d) added	221664
		Para. 4.2.4	: Existing text deleted and deviations (a) to (h) added	221664
		Para. 4.2.5	: "None" deleted and deviations (a) to (h) added	221664
		Para. 4.3.1	: Text amended	221664
		Para. 4.3.2	: Existing text deleted and new text added	221664
		Para. 4.3.3	: Existing text deleted and new text added	221664
		Para. 4.3.4	: Title expanded and text amended	221664
		Para. 4.3.5	: New paragraph added	221664/ 23960
		Paras. 4.3.6 to 4.3.8	: New paragraphs added	221664
		Paras. 4.3.9	: New paragraph added	221664/ 23960
		Paras. 4.3.10 to 4.3.13	: New paragraphs added	221664
		Para. 4.4.1	: Title and text amended	221664
		Para. 4.4.2	: New paragraph added and existing paragraph renumbered as "4.4.3"	221664
		Para. 4.4.3	: Renumbered as "4.4.5"	221664
		Para. 4.4.4	: New paragraph added and existing paragraph renumbered as "4.4.6"	221664
		Para. 4.4.7	: New paragraph added	221664
		Para. 4.5.1	: Text amended	221664
		Para. 4.5.2	: New paragraph added. Existing paragraph renumbered as "4.5.3", "Type Variant" amended and Note deleted.	221664/ 23960



DOCUMENTATION CHANGE NOTICE (CONTINUED)

Rev. Letter	Rev. Date	Reference	CHANGE Item	Approved DCR No.
		Para. 4.5.3	: Renumbered as "4.5.4"	221664
			: First sub-paragraph amended	221664
			: Last sub-paragraph amended	221664
		Para. 4.5.4	: Renumbered as "4.5.5"	221664
		Para. 4.7	: Title amended	221664
		Table 2	: Table expanded	221664
		Figure 3	: Figure added	221664
		Para. 4.8.1	: Text amended	221664
		Para. 4.8.3	: Text amended	221664
		Para. 4.8.6	: Second sentence amended	221664
		Table 6	: Table rewritten	221664/ 23960

**TABLE OF CONTENTS**

	<u>Page</u>
1. <u>GENERAL</u>	5
1.1 Scope	5
1.2 Component Type Variants/Range of Components	5
1.2.1 Shell Sizes for Variant 01	5
1.2.2 Shell Sizes for Variant 02	5
1.3 Maximum Ratings	5
1.4 Parameter Derating Information	5
1.5 Physical Dimensions	5
2. <u>APPLICABLE DOCUMENTS</u>	5
3. <u>TERMS, DEFINITIONS, ABBREVIATIONS, SYMBOLS AND UNITS</u>	17
4. <u>REQUIREMENTS</u>	17
4.1 General	17
4.2 Deviations from Generic Specification	17
4.2.1 Deviations from Special In-process Controls	17
4.2.2 Deviations from Final Production Tests	17
4.2.3 Deviations from Burn-in and Electrical Measurements	17
4.2.4 Deviations from Qualification Tests	17
4.2.5 Deviations from Lot Acceptance Tests	18
4.3 Mechanical Requirements	18
4.3.1 Dimension Check	18
4.3.2 Weight	18
4.3.3 Contact Capability	18
4.3.4 Contact Retention (In Insert)	18
4.3.5 Mating and Unmating Forces	18
4.3.6 Insert Retention (In Shell)	19
4.3.7 Jackscrew Retention	19
4.3.8 Contact Insertion and Withdrawal Forces	19
4.3.9 Engagement and Separation Forces (Male Contacts)	19
4.3.10 Oversize Pin Exclusion	19
4.3.11 Probe Damage	19
4.3.12 Solderability	19
4.3.13 Latching	19
4.4 Materials and Finishes	19
4.4.1 Inserts	19
4.4.2 Contacts	20
4.4.3 Guide Posts	20
4.4.4 Latching	20
4.4.5 Insulated Wires	20
4.4.6 Uninsulated Solid Wires	20
4.4.7 Rear Potting	20
4.5 Marking	20
4.5.1 General	20
4.5.2 Contact Identification	21
4.5.3 The SCC Component Number	21
4.5.4 Characteristics	21
4.5.5 Traceability Information	22



	<u>Page</u>
4.6 Electrical Measurements	22
4.6.1 Electrical Measurements at Room Temperature	22
4.6.2 Electrical Measurements at High and Low Temperatures	22
4.6.3 Circuits for Electrical Measurements	22
4.7 Burn-in and Electrical Measurements	22
4.8 Environmental and Endurance Tests	25
4.8.1 Measurements and Inspections on Completion of Environmental Tests	25
4.8.2 Measurements and Inspections at Intermediate Points during Endurance Tests	25
4.8.3 Measurements and Inspections on Completion of Endurance Tests	25
4.8.4 Conditions for Operating Life Tests	25
4.8.5 Electrical Circuits for Operating Life Tests	25
4.8.6 Conditions for High Temperature Storage Test	25

TABLES

1(a) Type Variants	6
1(b) Maximum Weights	6
1(c) Engagements and Separation Forces	6
1(d) Maximum Ratings	6
2 Electrical Measurements at Room Temperature	23
3 Not Applicable	23
4 Not Applicable	23
5 Not Applicable	23
6 Measurements and Inspections on Completion of Environmental and Endurance Tests	26

FIGURES

1 Parameter Derating Information	7
1(a) Working Voltage Versus Altitude	7
1(b) Maximum Current Versus Number of Contacts	7
2 Physical Dimensions	8
2.1(a) Connectors Plug - Male Contacts	8
2.1(b) Connectors Receptacle - Female Contacts	11
2.2 Uninsulated Solid Wires	14
2.3 Insulated Wires	14
2.4 Latching	15
2.5 Contact Position	16
3 Gauge Fixture	24
4 Not Applicable	N/A
5 Not Applicable	N/A

APPENDICES (Applicable to specific Manufacturers only)

None.

**1. GENERAL****1.1 SCOPE**

This specification details the ratings, physical and electrical characteristics, test and inspection data for Connectors, Electrical, Single-in-Line, Microminiature, based on Type MTB 1, with non-removable crimp-type contacts and their associated insulated wires and uninsulated solid wires.

It shall be read in conjunction with:

- (a) ESA/SCC Generic Specification No. 3401 for Connectors, Electrical, Non-filtered, Circular and Rectangular,

the requirements of which are supplemented herein.

1.2 COMPONENT TYPE VARIANTS / RANGE OF COMPONENTS

The single-in-line connectors specified herein are scheduled in Table 1(a). Alignment is effected by 2 guide posts; the posts are located at either end of the receptacle.

1.2.1 Shell sizes for Variant 01

These range from 5 to 81. Since 4 cavities are used (2 guide posts and 2 epoxy-filled cavities at either end) the number of available contact positions ranges from 1 to 77.

1.2.2 Shell sizes for Variant 02

These range from 6 to 81. Since 5 cavities are used (2 guide posts and 2 epoxy-filled cavities at either end plus 1 cavity for latching) the number of available contact positions ranges from 1 to 76.

Polarisation may be achieved by means of additional guide posts (according to Customer requirements). The different sizes of associated insulated wires and uninsulated solid wires are given in Figure 2. For bodies with more than 41 cavities, additional back-potting is necessary.

1.3 MAXIMUM RATINGS

The maximum ratings, which shall not be exceeded at any time during use or storage, applicable to the connectors specified herein, are scheduled in Table 1(d).

1.4 PARAMETER DERATING INFORMATION

The applicable derating information for the contacts specified herein is shown in Figure 1(a).

1.5 PHYSICAL DIMENSIONS

The physical dimensions of the connectors, insulated wires and uninsulated solid wires specified herein are shown in Figure 2.

2. APPLICABLE DOCUMENTS

The following documents form part of this specification and shall be read in conjunction with it:-

- (a) ESA/SCC Generic Specification No. 3401, Connectors, Electrical, Non-filtered, Circular and Rectangular.
- (b) ESA/SCC Detail Specification No. 3901/013, PTFE Insulated Wires and Cables, 600V -100 to +200 °C.
- (c) QQ-W-343, Wires, Electrical, Uninsulated.
- (d) MIL-G-45204, Gold-plating, Electro-deposited.
- (e) MIL-C-14550, Copper-plating, Electro-deposited.



TABLE 1(a) - TYPE VARIANTS

VARIANT	LATCHING OPTION
01	Without latching
02	With latching

TABLE 1(b) - MAXIMUM WEIGHTS

DESCRIPTION		WEIGHT (g)
Contact	Male	0.02
	Female	0.02
Body (per contact cavity)	Plug	0.21
	Receptacle	0.006
Guide Post, Stainless Steel (2 per connector)	-	0.035
Wire	Figures 2.2 and 2.3	

TABLE 1(c) - MATING AND UNMATING FORCES

DESCRIPTION	MATING		UNMATING	
	MIN.	MAX.	MIN.	MAX.
Per contact	-	2.2N	0.14N	2.2N

TABLE 1(d) - MAXIMUM RATINGS

No.	CHARACTERISTICS	SYMBOL	MAXIMUM RATING	UNIT
1	Working Voltage (Sea Level)	U_R	150	V _{rms}
2	Rated Current (AWG26 and Uninsulated Solid Wire)	I_R	2.5	A
3	Rated Current (AWG28)	I_R	1.5	A
4	Operating Temperature Range	T_{op}	-55 to +125	°C
5	Storage Temperature Range	T_{stg}	-55 to +125	°C



FIGURE 1 - PARAMETER DERATING INFORMATION

FIGURE 1(a) - WORKING VOLTAGE VERSUS ALTITUDE

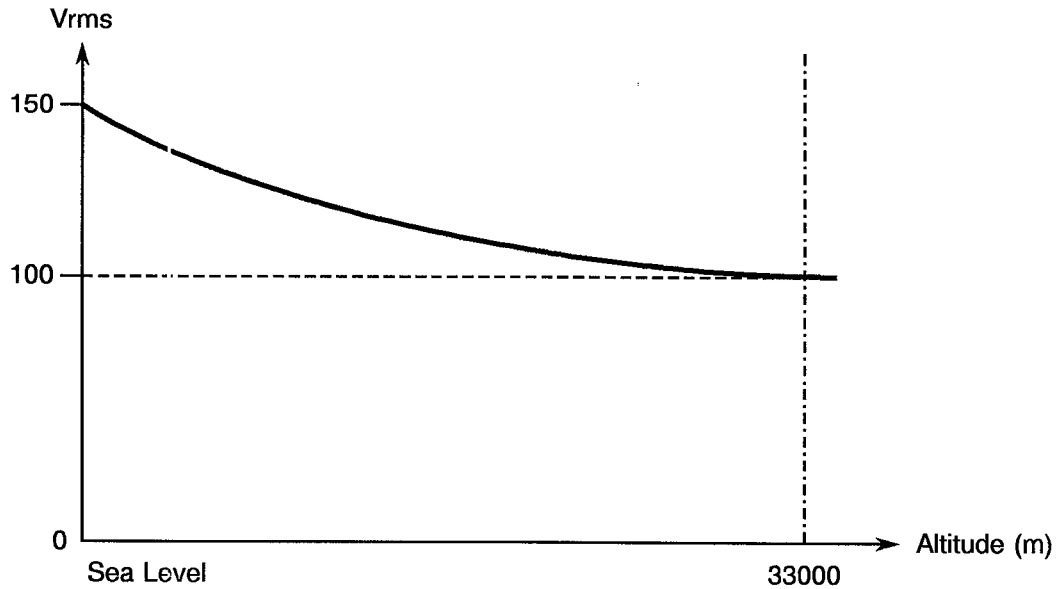


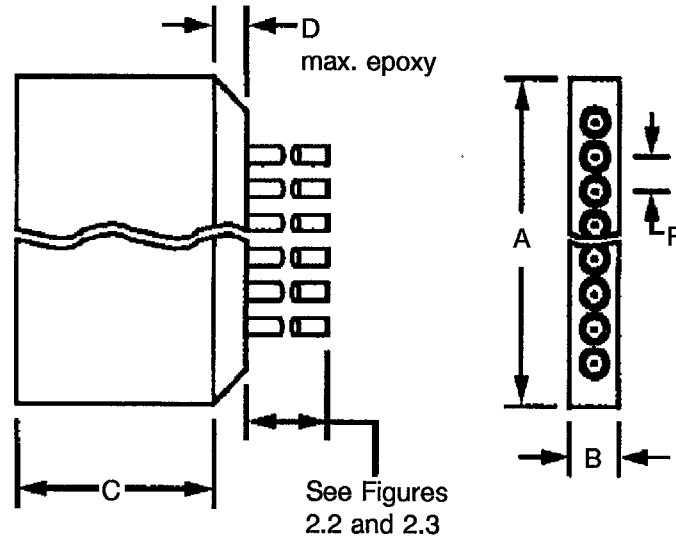
FIGURE 1(b) - MAXIMUM CURRENT VERSUS NUMBER OF CONTACTS

NUMBER OF CONTACTS PER CONNECTOR	MAXIMUM CURRENT PER CONTACT	
	WIRE SIZE	
	AWG26 AND UNINSULATED SOLID WIRE	AWG28
2-4	2.0	1.4
5-14	1.8	1.2
15 and over	1.4	0.9



FIGURE 2 - PHYSICAL DIMENSIONS

FIGURE 2.1(a) - CONNECTORS PLUG - MALE CONTACTS



See Figures 2.2 and 2.3

Shell Size	A		B		C		D	F
	Min.	Max.	Min.	Max.	Min.	Max.	Max.	Typical
5	6.47	7.23	1.9	2.16	7.06	7.32	3.18	1.27
6	7.75	8.51	1.9	2.16	7.06	7.32	3.18	1.27
7	9.02	9.78	1.9	2.16	7.06	7.32	3.18	1.27
8	10.29	11.05	1.9	2.16	7.06	7.32	3.18	1.27
9	11.56	12.32	1.9	2.16	7.06	7.32	3.18	1.27
10	12.82	13.58	1.9	2.16	7.06	7.32	3.18	1.27
11	14.10	14.86	1.9	2.16	7.06	7.32	3.18	1.27
12	15.37	16.13	1.9	2.16	7.06	7.32	3.18	1.27
13	16.64	17.40	1.9	2.16	7.06	7.32	3.18	1.27
14	17.91	18.67	1.9	2.16	7.06	7.32	3.18	1.27
15	19.18	20.04	1.9	2.16	7.06	7.32	3.18	1.27
16	20.45	21.21	1.9	2.16	7.06	7.32	3.18	1.27
17	21.72	22.48	1.9	2.16	7.06	7.32	3.18	1.27
18	22.99	23.75	1.9	2.16	7.06	7.32	3.18	1.27
19	24.26	25.02	1.9	2.16	7.06	7.32	3.18	1.27
20	25.53	26.29	1.9	2.16	7.06	7.32	3.18	1.27
21	26.8	27.56	1.9	2.16	7.06	7.32	3.18	1.27
22	28.07	28.83	1.9	2.16	7.06	7.32	3.18	1.27
23	29.34	30.10	1.9	2.16	7.06	7.32	3.18	1.27
24	30.61	31.47	1.9	2.16	7.06	7.32	3.18	1.27
25	31.88	32.64	1.9	2.16	7.06	7.32	3.18	1.27

NOTES

1. All dimensions are in millimetres.

**FIGURE 2 - PHYSICAL DIMENSIONS (CONTINUED)****FIGURE 2.1(a) - CONNECTORS PLUG - MALE CONTACTS (CONTINUED)**

Shell Size	A		B		C		D	F
	Min.	Max.	Min.	Max.	Min.	Max.	Max.	Typical
26	33.15	33.91	1.9	2.16	7.06	7.32	3.18	1.27
27	34.42	35.18	1.9	2.16	7.06	7.32	3.18	1.27
28	35.69	46.45	1.9	2.16	7.06	7.32	3.18	1.27
29	36.96	37.72	1.9	2.16	7.06	7.32	3.18	1.27
30	38.23	38.99	1.9	2.16	7.06	7.32	3.18	1.27
31	39.5	40.26	1.9	2.16	7.06	7.32	3.18	1.27
32	40.77	41.53	1.9	2.16	7.06	7.32	3.18	1.27
33	42.04	42.8	1.9	2.16	7.06	7.32	3.18	1.27
34	43.31	44.07	1.9	2.16	7.06	7.32	3.18	1.27
35	44.58	45.34	1.9	2.16	7.06	7.32	3.18	1.27
36	45.85	46.61	1.9	2.16	7.06	7.32	3.18	1.27
37	47.12	47.88	1.9	2.16	7.06	7.32	3.18	1.27
38	48.39	49.15	1.9	2.16	7.06	7.32	3.18	1.27
39	49.66	50.42	1.9	2.16	7.06	7.32	3.18	1.27
40	50.93	51.69	1.9	2.16	7.06	7.32	3.18	1.27
41	52.2	52.96	1.9	2.16	7.06	7.32	3.18	1.27
42	53.47	54.23	1.9	2.16	7.06	7.32	3.18	1.27
43	54.74	55.5	1.9	2.16	7.06	7.32	3.18	1.27
44	56.01	56.77	1.9	2.16	7.06	7.32	3.18	1.27
45	57.28	58.04	1.9	2.16	7.06	7.32	3.18	1.27
46	58.55	59.31	1.9	2.16	7.06	7.32	3.18	1.27
47	59.82	60.58	1.9	2.16	7.06	7.32	3.18	1.27
48	61.09	61.85	1.9	2.16	7.06	7.32	3.18	1.27
49	62.36	63.12	1.9	2.16	7.06	7.32	3.18	1.27
50	63.63	64.39	1.9	2.16	7.06	7.32	3.18	1.27
51	64.9	65.66	1.9	2.16	7.06	7.32	3.18	1.27
52	66.13	66.89	1.9	2.16	7.06	7.32	3.18	1.27
53	67.44	68.2	1.9	2.16	7.06	7.32	3.18	1.27
54	68.71	69.47	1.9	2.16	7.06	7.32	3.18	1.27
55	69.98	70.74	1.9	2.16	7.06	7.32	3.18	1.27
56	71.25	72.01	1.9	2.16	7.06	7.32	3.18	1.27
57	72.52	73.28	1.9	2.16	7.06	7.32	3.18	1.27
58	73.79	74.54	1.9	2.16	7.06	7.32	3.18	1.27
59	75.06	75.82	1.9	2.16	7.06	7.32	3.18	1.27
60	76.33	77.09	1.9	2.16	7.06	7.32	3.18	1.27
61	76.6	78.36	1.9	2.16	7.06	7.32	3.18	1.27
62	78.87	79.53	1.9	2.16	7.06	7.32	3.18	1.27
63	80.14	80.9	1.9	2.16	7.06	7.32	3.18	1.27
64	81.41	82.37	1.9	2.16	7.06	7.32	3.18	1.27
65	82.68	83.44	1.9	2.16	7.06	7.32	3.18	1.27

NOTES

1. All dimensions are in millimetres.



FIGURE 2 - PHYSICAL DIMENSIONS (CONTINUED)

FIGURE 2.1(a) - CONNECTORS PLUG - MALE CONTACTS (CONTINUED)

Shell Size	A		B		C		D	F
	Min.	Max.	Min.	Max.	Min.	Max.	Max.	Typical
66	83.95	84.71	1.9	2.16	7.06	7.32	3.18	1.27
67	85.22	86.08	1.9	2.16	7.06	7.32	3.18	1.27
68	86.39	87.15	1.9	2.16	7.06	7.32	3.18	1.27
69	87.76	88.52	1.9	2.16	7.06	7.32	3.18	1.27
70	89.03	89.79	1.9	2.16	7.06	7.32	3.18	1.27
71	90.3	91.06	1.9	2.16	7.06	7.32	3.18	1.27
72	91.57	92.33	1.9	2.16	7.06	7.32	3.18	1.27
73	92.34	93.6	1.9	2.16	7.06	7.32	3.18	1.27
74	94.11	94.87	1.9	2.16	7.06	7.32	3.18	1.27
75	95.38	96.14	1.9	2.16	7.06	7.32	3.18	1.27
76	96.65	97.41	1.9	2.16	7.06	7.32	3.18	1.27
77	97.92	98.68	1.9	2.16	7.06	7.32	3.18	1.27
78	98.19	99.05	1.9	2.16	7.06	7.32	3.18	1.27
79	100.46	101.22	1.9	2.16	7.06	7.32	3.18	1.27
80	101.73	102.49	1.9	2.16	7.06	7.32	3.18	1.27
81	103	103.76	1.9	2.16	7.06	7.32	3.18	1.27

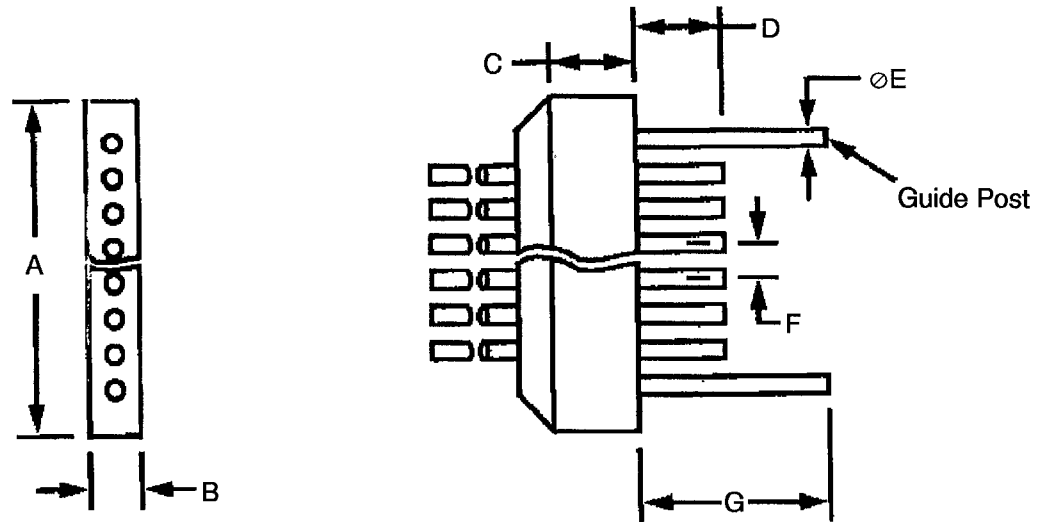
NOTES

1. All dimensions are in millimetres.



FIGURE 2 - PHYSICAL DIMENSIONS (CONTINUED)

FIGURE 2.1(b) - CONNECTORS RECEPTACLE - FEMALE CONTACTS



Shell Size	A		B		C		D		ØE		F	G	
	Min.	Max.	Min.	Max.	Min.	Max.	Min.	Max.	Min.	Max.	Typical	Min.	Max.
5	6.47	7.23	1.9	2.16	2.41	2.67	3.07	3.33	0.78	0.84	1.27	4.83	5.33
6	7.75	8.51	1.9	2.16	2.41	2.67	3.07	3.33	0.78	0.84	1.27	4.83	5.33
7	9.02	9.78	1.9	2.16	2.41	2.67	3.07	3.33	0.78	0.84	1.27	4.83	5.33
8	10.29	11.05	1.9	2.16	2.41	2.67	3.07	3.33	0.78	0.84	1.27	4.83	5.33
9	11.56	12.32	1.9	2.16	2.41	2.67	3.07	3.33	0.78	0.84	1.27	4.83	5.33
10	12.82	13.58	1.9	2.16	2.41	2.67	3.07	3.33	0.78	0.84	1.27	4.83	5.33
11	14.1	14.86	1.9	2.16	2.41	2.67	3.07	3.33	0.78	0.84	1.27	4.83	5.33
12	15.37	16.13	1.9	2.16	2.41	2.67	3.07	3.33	0.78	0.84	1.27	4.83	5.33
13	16.64	17.4	1.9	2.16	2.41	2.67	3.07	3.33	0.78	0.84	1.27	4.83	5.33
14	17.91	18.67	1.9	2.16	2.41	2.67	3.07	3.33	0.78	0.84	1.27	4.83	5.33
15	19.18	20.04	1.9	2.16	2.41	2.67	3.07	3.33	0.78	0.84	1.27	4.83	5.33
16	20.45	21.21	1.9	2.16	2.41	2.67	3.07	3.33	0.78	0.84	1.27	4.83	5.33
17	21.72	22.48	1.9	2.16	2.41	2.67	3.07	3.33	0.78	0.84	1.27	4.83	5.33
18	22.99	23.75	1.9	2.16	2.41	2.67	3.07	3.33	0.78	0.84	1.27	4.83	5.33
19	24.26	25.02	1.9	2.16	2.41	2.67	3.07	3.33	0.78	0.84	1.27	4.83	5.33
20	25.53	26.29	1.9	2.16	2.41	2.67	3.07	3.33	0.78	0.84	1.27	4.83	5.33
21	26.8	27.56	1.9	2.16	2.41	2.67	3.07	3.33	0.78	0.84	1.27	4.83	5.33
22	28.07	28.83	1.9	2.16	2.41	2.67	3.07	3.33	0.78	0.84	1.27	4.83	5.33
23	29.34	30.1	1.9	2.16	2.41	2.67	3.07	3.33	0.78	0.84	1.27	4.83	5.33
24	30.61	31.47	1.9	2.16	2.41	2.67	3.07	3.33	0.78	0.84	1.27	4.83	5.33
25	31.88	32.64	1.9	2.16	2.41	2.67	3.07	3.33	0.78	0.84	1.27	4.83	5.33

NOTES

1. All dimensions are in millimetres.



FIGURE 2 - PHYSICAL DIMENSIONS (CONTINUED)

FIGURE 2.1(b) - CONNECTORS RECEPTACLE - FEMALE CONTACTS (CONTINUED)

Shell Size	A		B		C		D		ØE		F	G	
	Min.	Max.	Min.	Max.	Min.	Max.	Min.	Max.	Min.	Max.	Typical	Min.	Max.
26	33.15	33.91	1.9	2.16	2.41	2.67	3.07	3.33	0.78	0.84	1.27	4.83	5.33
27	34.42	35.18	1.9	2.16	2.41	2.67	3.07	3.33	0.78	0.84	1.27	4.83	5.33
28	35.69	46.45	1.9	2.16	2.41	2.67	3.07	3.33	0.78	0.84	1.27	4.83	5.33
29	36.96	37.72	1.9	2.16	2.41	2.67	3.07	3.33	0.78	0.84	1.27	4.83	5.33
30	38.23	38.99	1.9	2.16	2.41	2.67	3.07	3.33	0.78	0.84	1.27	4.83	5.33
31	39.5	40.26	1.9	2.16	2.41	2.67	3.07	3.33	0.78	0.84	1.27	4.83	5.33
32	40.77	41.53	1.9	2.16	2.41	2.67	3.07	3.33	0.78	0.84	1.27	4.83	5.33
33	42.04	42.8	1.9	2.16	2.41	2.67	3.07	3.33	0.78	0.84	1.27	4.83	5.33
34	43.31	44.07	1.9	2.16	2.41	2.67	3.07	3.33	0.78	0.84	1.27	4.83	5.33
35	44.58	45.34	1.9	2.16	2.41	2.67	3.07	3.33	0.78	0.84	1.27	4.83	5.33
36	45.85	46.61	1.9	2.16	2.41	2.67	3.07	3.33	0.78	0.84	1.27	4.83	5.33
37	47.12	47.88	1.9	2.16	2.41	2.67	3.07	3.33	0.78	0.84	1.27	4.83	5.33
38	48.39	49.15	1.9	2.16	2.41	2.67	3.07	3.33	0.78	0.84	1.27	4.83	5.33
39	49.66	50.42	1.9	2.16	2.41	2.67	3.07	3.33	0.78	0.84	1.27	4.83	5.33
40	50.93	51.69	1.9	2.16	2.41	2.67	3.07	3.33	0.78	0.84	1.27	4.83	5.33
41	52.2	52.96	1.9	2.16	2.41	2.67	3.07	3.33	0.78	0.84	1.27	4.83	5.33
42	53.47	54.23	1.9	2.16	2.41	2.67	3.07	3.33	0.78	0.84	1.27	4.83	5.33
43	54.74	55.5	1.9	2.16	2.41	2.67	3.07	3.33	0.78	0.84	1.27	4.83	5.33
44	56.01	56.77	1.9	2.16	2.41	2.67	3.07	3.33	0.78	0.84	1.27	4.83	5.33
45	57.28	58.04	1.9	2.16	2.41	2.67	3.07	3.33	0.78	0.84	1.27	4.83	5.33
46	58.55	59.31	1.9	2.16	2.41	2.67	3.07	3.33	0.78	0.84	1.27	4.83	5.33
47	59.82	60.58	1.9	2.16	2.41	2.67	3.07	3.33	0.78	0.84	1.27	4.83	5.33
48	61.09	61.85	1.9	2.16	2.41	2.67	3.07	3.33	0.78	0.84	1.27	4.83	5.33
49	62.36	63.12	1.9	2.16	2.41	2.67	3.07	3.33	0.78	0.84	1.27	4.83	5.33
50	63.63	64.39	1.9	2.16	2.41	2.67	3.07	3.33	0.78	0.84	1.27	4.83	5.33
51	64.9	65.66	1.9	2.16	2.41	2.67	3.07	3.33	0.78	0.84	1.27	4.83	5.33
52	66.13	66.89	1.9	2.16	2.41	2.67	3.07	3.33	0.78	0.84	1.27	4.83	5.33
53	67.44	68.2	1.9	2.16	2.41	2.67	3.07	3.33	0.78	0.84	1.27	4.83	5.33
54	68.71	69.47	1.9	2.16	2.41	2.67	3.07	3.33	0.78	0.84	1.27	4.83	5.33
55	69.98	70.74	1.9	2.16	2.41	2.67	3.07	3.33	0.78	0.84	1.27	4.83	5.33
56	71.25	72.01	1.9	2.16	2.41	2.67	3.07	3.33	0.78	0.84	1.27	4.83	5.33
57	72.52	73.28	1.9	2.16	2.41	2.67	3.07	3.33	0.78	0.84	1.27	4.83	5.33
58	73.79	74.54	1.9	2.16	2.41	2.67	3.07	3.33	0.78	0.84	1.27	4.83	5.33
59	75.06	75.82	1.9	2.16	2.41	2.67	3.07	3.33	0.78	0.84	1.27	4.83	5.33
60	76.33	77.09	1.9	2.16	2.41	2.67	3.07	3.33	0.78	0.84	1.27	4.83	5.33
61	77.6	78.36	1.9	2.16	2.41	2.67	3.07	3.33	0.78	0.84	1.27	4.83	5.33
62	78.87	79.53	1.9	2.16	2.41	2.67	3.07	3.33	0.78	0.84	1.27	4.83	5.33
63	80.14	80.9	1.9	2.16	2.41	2.67	3.07	3.33	0.78	0.84	1.27	4.83	5.33
64	81.41	82.37	1.9	2.16	2.41	2.67	3.07	3.33	0.78	0.84	1.27	4.83	5.33
65	82.68	83.44	1.9	2.16	2.41	2.67	3.07	3.33	0.78	0.84	1.27	4.83	5.33

NOTES

1. All dimensions are in millimetres.



FIGURE 2 - PHYSICAL DIMENSIONS (CONTINUED)

FIGURE 2.1(b) - CONNECTORS RECEPTACLE - FEMALE CONTACTS (CONTINUED)

Shell Size	A		B		C		D		ØE		F	G	
	Min.	Max.	Min.	Max.	Min.	Max.	Min.	Max.	Min.	Max.	Typical	Min.	Max.
66	83.95	84.71	1.9	2.16	2.41	2.67	3.07	3.33	0.78	0.84	1.27	4.83	5.33
67	85.22	86.08	1.9	2.16	2.41	2.67	3.07	3.33	0.78	0.84	1.27	4.83	5.33
68	86.39	87.15	1.9	2.16	2.41	2.67	3.07	3.33	0.78	0.84	1.27	4.83	5.33
69	87.76	88.52	1.9	2.16	2.41	2.67	3.07	3.33	0.78	0.84	1.27	4.83	5.33
70	89.03	89.79	1.9	2.16	2.41	2.67	3.07	3.33	0.78	0.84	1.27	4.83	5.33
71	90.3	91.06	1.9	2.16	2.41	2.67	3.07	3.33	0.78	0.84	1.27	4.83	5.33
72	91.57	92.33	1.9	2.16	2.41	2.67	3.07	3.33	0.78	0.84	1.27	4.83	5.33
73	92.84	93.6	1.9	2.16	2.41	2.67	3.07	3.33	0.78	0.84	1.27	4.83	5.33
74	94.11	94.87	1.9	2.16	2.41	2.67	3.07	3.33	0.78	0.84	1.27	4.83	5.33
75	95.38	96.14	1.9	2.16	2.41	2.67	3.07	3.33	0.78	0.84	1.27	4.83	5.33
76	96.65	97.41	1.9	2.16	2.41	2.67	3.07	3.33	0.78	0.84	1.27	4.83	5.33
77	97.92	98.68	1.9	2.16	2.41	2.67	3.07	3.33	0.78	0.84	1.27	4.83	5.33
78	98.19	99.05	1.9	2.16	2.41	2.67	3.07	3.33	0.78	0.84	1.27	4.83	5.33
79	100.46	101.22	1.9	2.16	2.41	2.67	3.07	3.33	0.78	0.84	1.27	4.83	5.33
80	101.73	102.49	1.9	2.16	2.41	2.67	3.07	3.33	0.78	0.84	1.27	4.83	5.33
81	103	103.76	1.9	2.16	2.41	2.67	3.07	3.33	0.78	0.84	1.27	4.83	5.33

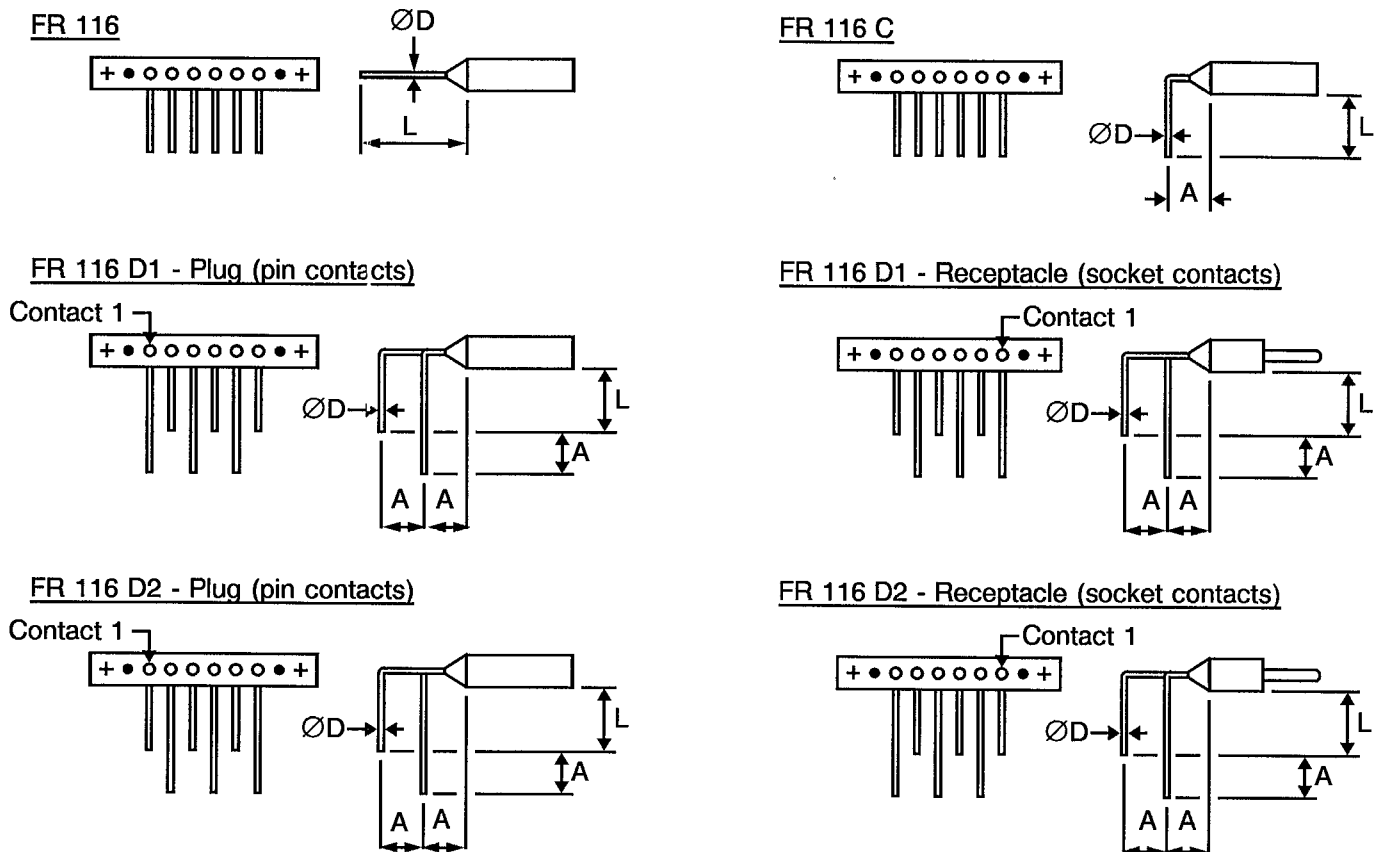
NOTES

1. All dimensions are in millimetres.



FIGURE 2 - PHYSICAL DIMENSIONS (CONTINUED)

FIGURE 2.2 - UNINSULATED SOLID WIRES



TERMINATIONS CODE	FR 116	FR 116 C	FR 116 D1	FR 116 D2
Wire Size (AWG)	25	25	25	25
Max. Diameter 'D' (mm)	0.46	0.46	0.46	0.46
Min. Diameter 'D' (mm)	0.45	0.45	0.45	0.45
Max. Weight (g/m)	1.60	1.60	1.60	1.60
Min. Gold-plating Thickness (μm)	0.50	0.50	0.50	0.50
\underline{L} (mm)	25	4	4	4
\underline{A} (mm)	-	2.54	2.54	2.54

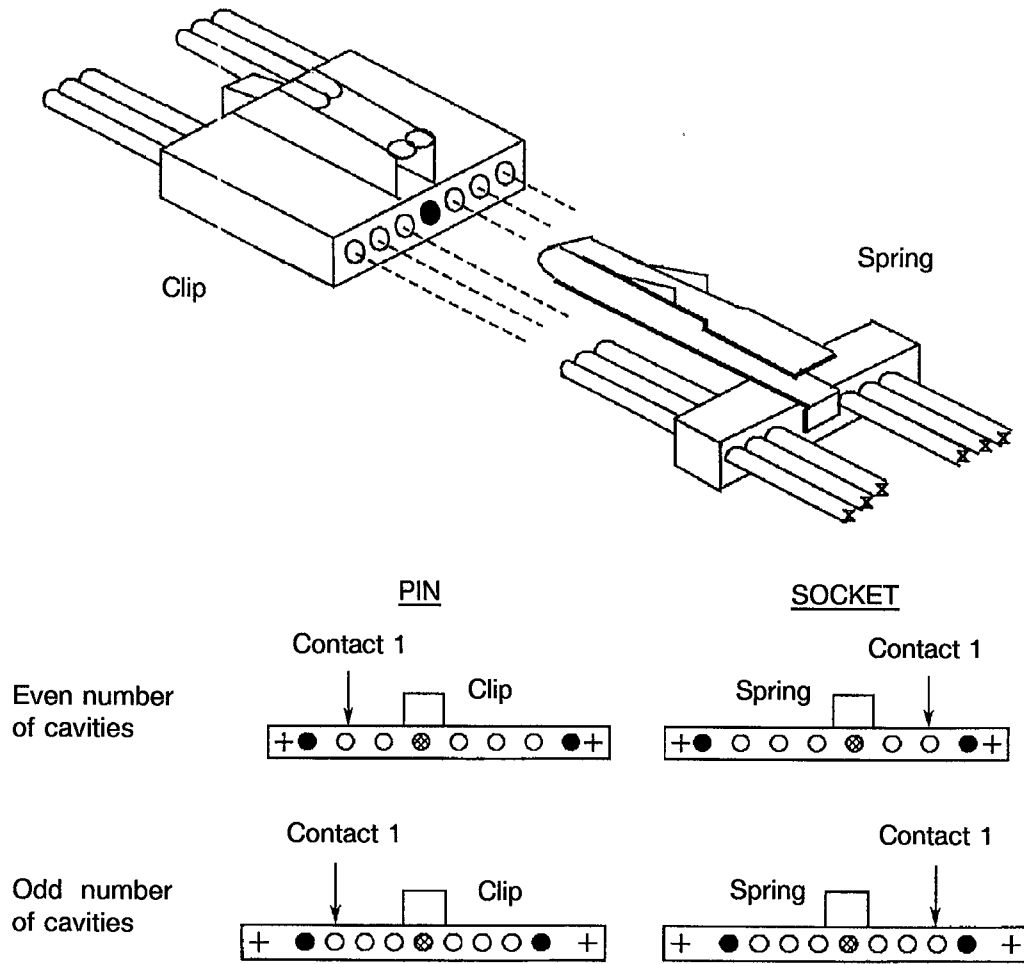
FIGURE 2.3 - INSULATED WIRES

WIRE SIZE AWG		26	28
Conductor Characteristics	Maximum diameter (mm)	0.50	0.42
	Nominal cross-section (mm^2)	0.14	0.10
Finished Wire Characteristics	Maximum diameter (mm)	0.89	0.82
	Maximum weight (g/m)	2.3	1.8
	Colour	Natural	Natural
	Minimum length	See Para. 4.5.4.3	

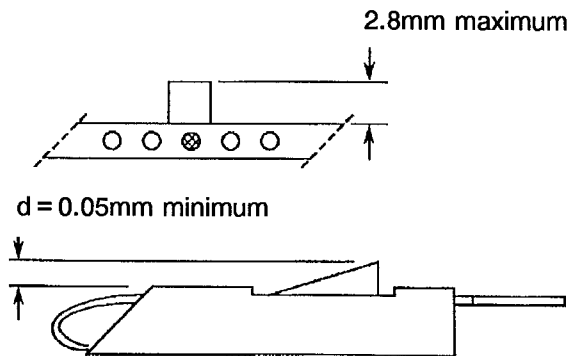


FIGURE 2 - PHYSICAL DIMENSIONS (CONTINUED)

FIGURE 2.4 - LATCHING



(Seen from contact side)



Latching force = 10N maximum



FIGURE 2 - PHYSICAL DIMENSIONS (CONTINUED)

FIGURE 2.5 - CONTACT POSITION

Figure 2.5.1 - Mounting Condition

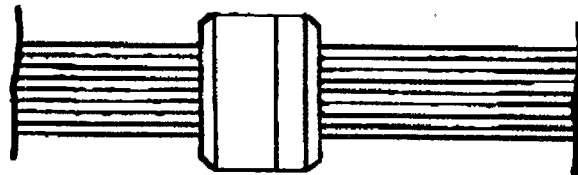


Figure 2.5.2 - Plug Male Contact

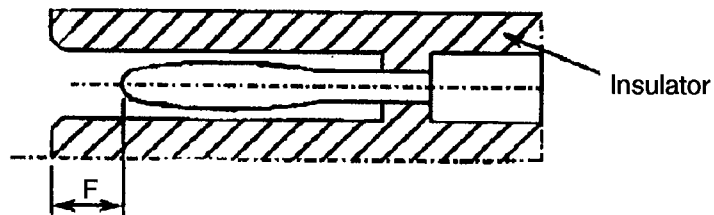
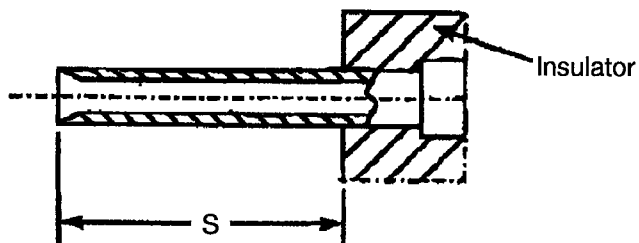


Figure 2.5.3 - Receptacle Female Contact



F		S	
Min.	Max.	Min.	Max.
0.25	0.91	3.07	3.33

NOTES

1. All dimensions are in millimetres.



3. TERMS, DEFINITIONS, ABBREVIATIONS, SYMBOLS AND UNITS

For the purpose of this specification, the terms, definitions, abbreviations, symbols and units specified in ESA/SCC Basic Specification No. 21300 shall apply.

4. REQUIREMENTS

4.1 GENERAL

The complete requirements for procurement of the connectors specified herein are as stated in this specification and ESA/SCC Generic Specification No. 3401. Deviations from the Generic Specification, applicable to this specification only, are listed in Para. 4.2.

Deviations from the applicable Generic Specification and this Detail Specification, formally agreed with specific Manufacturers on the basis that the alternative requirements are equivalent to the ESA/SCC requirements and do not affect the components' reliability, are listed in the appendices attached to this specification.

4.2 DEVIATIONS FROM GENERIC SPECIFICATION

4.2.1 Deviations from Special In-process Controls

(a) Para. 9.15, Joint Strength: The contacts shall be crimped to insulated stranded wire AWG26 and AWG28 and to uninsulated solid wire AWG25. The value of failure shall be recorded together with the information as to whether the failure was "pull-out", "break in crimp" or "break in wire". The minimum tensile strength shall be as follows.

WIRE	MALE AND FEMALE CONTACTS		
	AWG26	AWG28	AWG25 - Solid Uninsulated
Tensile Strength (N)	22	13	22

4.2.2 Deviations from Final Production Tests (Chart II)

- (a) Para. 9.1.1.4, Mated Shell Conductivity: Not applicable.
- (b) Para. 9.3, Contact Retainer Test: Not applicable.
- (c) Para. 9.4, Contact Capability: This test shall be performed on male contacts. For details see Para. 4.3.3 of this specification.
- (d) Para. 9.5, Magnetism Level: Not applicable.

4.2.3 Deviations from Burn-in and Electrical Measurements (Chart III)

Not applicable.

4.2.4 Deviations from Qualification Tests (Chart IV)

- (a) Para. 9.1.1.4, Mated Shell Conductivity: Not applicable.
- (b) Para. 9.9, Seal Test: Not applicable.
- (c) Para. 9.15, Joint Strength: Not applicable.
- (d) Para. 9.17, Contact Retention (In Insert): Not applicable with male contact.
- (e) Para. 9.27, Maintenance Ageing: Not applicable.



- (f) Para. 9.29, Oversize Pin Exclusion: Not applicable.
- (g) Para. 9.30, Probe Damage: Not applicable.
- (h) Latching shall be performed as specified in Para. 4.3.13 of this specification.

4.2.5 Deviations from Lot Acceptance Tests (Chart V)

- (a) Para. 9.1.1.4, Mated Shell Conductivity: Not applicable.
- (b) Para. 9.9, Seal Test: Not applicable.
- (c) Para. 9.15, Joint Strength: Not applicable.
- (d) Para. 9.17, Contact Retention (In Insert): Not applicable with male contact.
- (e) Para. 9.27, Maintenance Ageing: Not applicable.
- (f) Para. 9.29, Oversize Pin Exclusion: Not applicable.
- (g) Para. 9.30, Probe Damage: Not applicable.
- (h) Latching shall be performed as specified in Para. 4.3.13 of this specification.

4.3 MECHANICAL REQUIREMENTS

4.3.1 Dimension Check

The dimensions of the connectors specified herein shall be verified in accordance with the requirements set out in Para. 9.6 of ESA/SCC Generic Specification No. 3401 and shall conform to those shown in Figure 2 of this specification. Only the underlined dimensions shall be checked during procurement.

4.3.2 Weight

The maximum weight of the connectors specified herein shall be calculated on the basis of, and be in accordance with, the values given in Table 1(b) and in Figures 2.2 and 2.3 of this specification.

4.3.3 Contact Capability

For the purpose of this test, the pick-up and drop weights shall be as follows.

MEASUREMENTS	PICK-UP WEIGHT	DROP WEIGHT
Weight (g)	14	170
Inner Gauge Diameter (mm) (1)	0.582 - 0.587	0.559 - 0.564
Insertion Depth (mm)	1.5	1.5

NOTES

1. See Figure 3 for $\varnothing A$.

4.3.4 Contact Retention (In Insert)

Contact retention within the insert shall be 22.25 Newtons. There shall be no displacement of the contact. Not applicable to male contacts.

4.3.5 Mating and Unmating Forces

The forces applied for the mating and unmating of the connectors shall conform to the values specified in Table 1(c).



4.3.6 Insert Retention (In Shell)

Not applicable.

4.3.7 Jackscrew Retention

Not applicable.

4.3.8 Contact Insertion and Withdrawal Forces

Not applicable.

4.3.9 Engagement and Separation Forces (Male Contacts)

The contact engagement and separation forces of the male contacts shall be tested to a depth of 1.5mm with the applicable test gauge fixture specified in Figure 3 of this specification, and shall not exceed the values of the table hereunder.

MEASUREMENTS	INNER DIAMETER (mm)		SEPARATION FORCE Min. (N)	ENGAGEMENT FORCE Max. (N)
	Min.	Max.		
Max. Gauge Fixture	0.559	0.564	-	1.667
Min. Gauge Fixture	0.582	0.587	0.137	-

4.3.10 Oversize Pin Exclusion

Not applicable.

4.3.11 Probe Damage

Not applicable.

4.3.12 Solderability

Not applicable.

4.3.13 Latching

Unlocking is achieved by applying a force of 3N minimum, perpendicular to the connector at the end of the spring.

The endurance test (10 cycles of mating/unmating) shall be performed with the force, applied at the end of the spring, necessary to achieve a travel of 1mm (unlocking travel = 0.5mm, total travel = 1.15mm). The requirement after the endurance test is that dimension d = 0.05mm, minimum.

4.4 MATERIALS AND FINISHES

The materials and finishes shall be as specified herein. Where a definite material is not specified, a material which will enable the connectors specified herein to meet the performance requirements of this specification shall be used. Acceptance or approval of any constituent material does not guarantee acceptance of the finished product.

4.4.1 Inserts

Inserts shall be made of glass fibre-filled diallylphtalate resin or suitable thermoplastic material.



4.4.2 Contacts

4.4.2.1 Female Contacts

The contact body shall be made of copper alloy with an underplate of 1.0 μ m minimum of copper to MIL-C-14550, gold plated with 1.27 μ m minimum of gold, Type 2, Grade C of MIL-G-45204. Measurement of thickness shall be performed at a distance of 1.5mm from the engagement end.

4.4.2.2 Male Contacts

The contact body and the bundle shall be made of copper alloy with an underplate of 1.0 μ m minimum of copper to MIL-C-14550, gold plated with 1.27 μ m minimum of gold, Type 2, Grade C of MIL-G-45204. Measurement of thickness shall be performed at a distance of 1.5mm from the engagement end.

4.4.3 Guide Posts

Guide posts shall be made from passivated stainless steel, Type 303.

4.4.4 Latching

Clip and spring shall be made of passivated stainless steel.

4.4.5 Insulated Wires

Wire materials and finishes shall be in accordance with the requirements specified in Para. 4.4 of ESA/SCC Detail Specification No. 3901/013.

4.4.6 Uninsulated Solid Wires

Uninsulated solid wires shall be made of copper alloy in accordance with Type 'S' as specified in QQ-W-343. They shall be gold-plated in accordance with Class $\Phi\Phi$, Grade C or D, as specified in MIL-G-45204.

4.4.7 Rear Potting

Rear potting shall be made of epoxy resin.

4.5 MARKING

4.5.1 General

The marking of all components delivered to this specification shall be in accordance with the requirements of ESA/SCC Basic Specification No. 21700 and the following paragraphs.

When the component is too small to accommodate all of the marking specified, as much as space permits shall be marked and the marking information, in full, shall accompany the component in its primary package.

The information to be marked and the order of precedence shall be as follows:-

- (a) The SCC Component Number.
- (b) Characteristics.
- (c) Traceability Information.

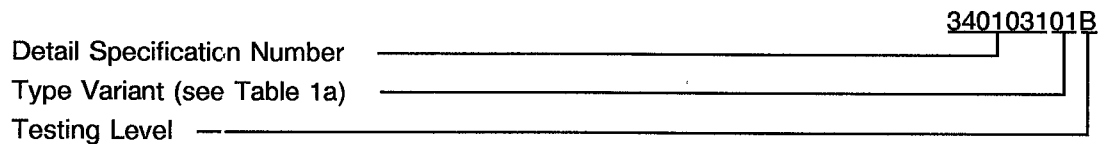


4.5.2 Contact Identification

Not applicable.

4.5.3 The SCC Component Number

The SCC Component Number shall be constituted and marked as follows:

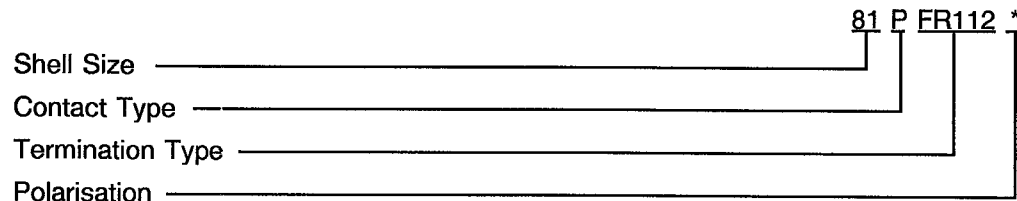


4.5.4 Characteristics

The characteristics to be marked in the following order of precedence are:-

- (a) Shell Size.
- (b) Contact Type.
- (c) Termination Type.
- (d) Polarisation (optional).

The information shall be constituted and marked as follows:-



4.5.4.1 Shell Size

The shell size shall be designated by 2 digits representing the number of available cavities plus 4 additional cavities plus (see Para. 1.2):-

- (a) 4 additional cavities for Variant 01 - The specified numbers range from 05 through to 87 maximum.
- (b) 5 additional cavities for Variant 02 - The specified numbers range from 06 through to 87 maximum.

4.5.4.2 Contact Types

Contact types shall be indicated by the following code letters.

Code Letter	Contact Type
P	Male
S	Female



4.5.4.3 Termination Types

Termination types define length of insulated wire or uninsulated solid wire according to Figures 2.2 and 2.3 as follows.

Code	Type (see Figure 2)	Min. Length (mm)
FR 112	Wire AWG 26	508
FR 113	Wire AWG 26	914
FR 114	Wire AWG 28	508
FR 115	Wire AWG 28	918
FR 116	Uninsulated Solid Wire	25
FR 116 C	Uninsulated Solid 90°C Formed Wire	4
FR 116 D1	Uninsulated Solid 90°C Formed Wire (Long Terminations on Odd Contacts)	4
FR 116 D2	Uninsulated Solid 90°C Formed Wire (Long Terminations on Even Contacts)	4

4.5.4.4 Polarisation

The marking of the cavity number used for the polarisation is optional and is used only in case the Orderer wishes to specify his own polarisation means by epoxy-filled cavities or guide posts (see Para. 1.2). There is no mandatory requirement for this part of the marking.

4.5.5 Traceability Information

Traceability information shall be marked in accordance with the requirements of ESA/SCC Basic Specification No. 21700.

4.6 ELECTRICAL MEASUREMENTS

4.6.1 Electrical Measurements at Room Temperature

The parameters to be measured in respect of electrical characteristics are scheduled in Table 2. Unless otherwise specified, the measurements shall be performed at $T_{amb} = +22 \pm 3^{\circ}\text{C}$.

4.6.2 Electrical Measurements at High and Low Temperatures

Not applicable.

4.6.3 Circuits for Electrical Measurements (Figure 4)

Not applicable

4.7 BURN IN AND ELECTRICAL MEASUREMENTS

Not applicable.

**TABLE 2 - ELECTRICAL MEASUREMENTS AT ROOM TEMPERATURE**

No.	CHARACTERISTICS	SYMBOL	ESA/SCC 3401 TEST METHOD	TEST CONDITIONS	LIMITS		UNIT
					MIN.	MAX.	
1	Insulation Resistance	Ri	Para. 9.1.1.1	Para. 9.1.1.1	5000	-	MΩ
2	Voltage Proof Leakage Current	I _L	Para. 9.1.1.2	600 Vrms	-	2.0	mA
3	Mated Shell Conductivity (Voltage Drop) (1)	Vd	Para. 9.1.1.4	Para. 9.1.1.4	Not applicable		mV
4	Contact Resistance (Low Level Current)	Rcl max.	Para. 9.1.1.3	Para. 9.1.1.3	-	6.0	mΩ
5	Contact Resistance (Rated Current)	Rcr max.	Para. 9.1.1.3	Table 1(d)	-	5.0	mΩ

NOTES

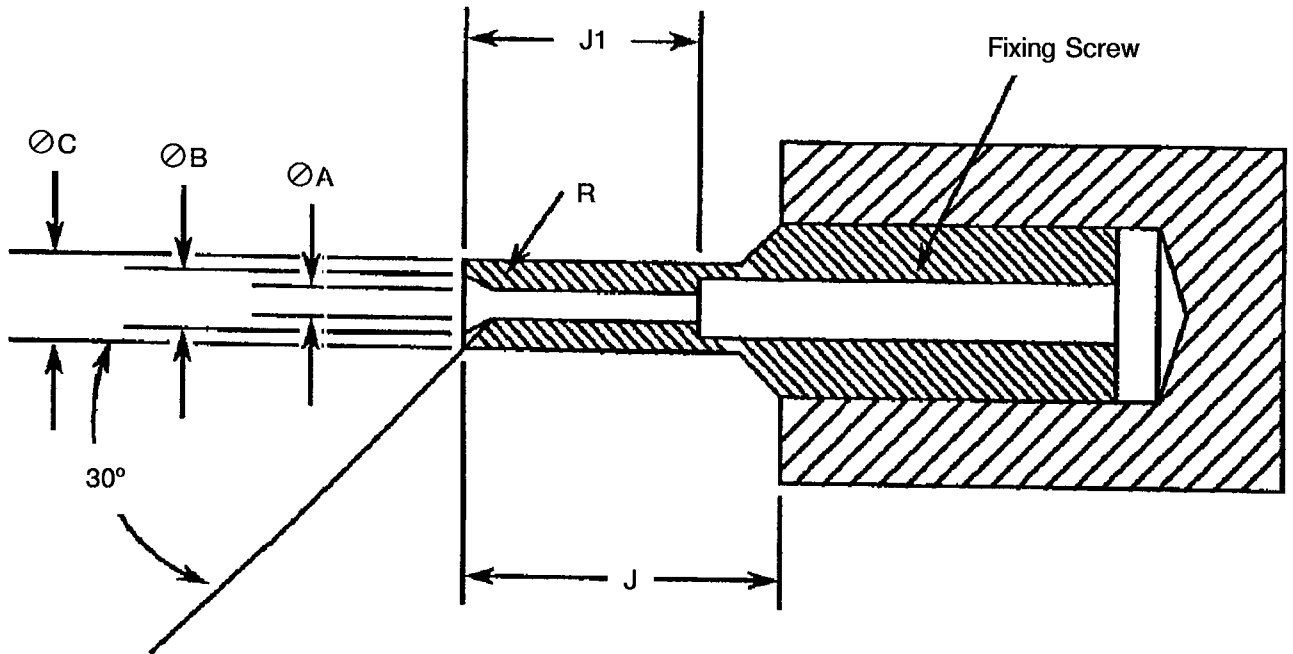
1. Applicable to mated connectors with grounding option.

TABLES 3, 4 AND 5

Not applicable.



FIGURE 3 - GAUGE FIXTURE



MAXIMUM GAUGE

WEIGHT (g) 170			REMARKS
	MIN.	MAX.	
ØA	0.559	0.564	-
ØB	0.749	0.775	-
ØC	0.813	0.825	-
J	4.0	-	-
J1	3.13	3.23	-
R	0.381	0.483	Note 1

MINIMUM GAUGE

WEIGHT (g) 14			REMARKS
	MIN.	MAX.	
ØA	0.582	0.587	-
ØB	0.749	0.775	-
ØC	0.813	0.825	-
J	4.0	-	-
J1	3.13	3.23	-
R	0.381	0.483	Note 1

NOTES

1. Radius "R" must be tangent to entry chamfer and ØA.
2. ØA and entry chamfer must be polished to $\frac{N8}{\sqrt{\text{V}}}$.



- 4.8 ENVIRONMENTAL AND ENDURANCE TESTS (CHARTS IV AND V OF ESA/SCC GENERIC SPECIFICATION NO. 3401)
- 4.8.1 Measurements and Inspections on Completion of Environmental Tests
The parameters to be measured and inspections to be performed on completion of environmental tests shall be those scheduled in Table 6. Unless otherwise stated, the measurements shall be performed at $T_{amb} = +22 \pm 3$ °C.
- 4.8.2 Measurements and Inspections at Intermediate Points during Endurance Tests
Not applicable.
- 4.8.3 Measurements and Inspections on Completion of Endurance Tests
The parameters to be measured and inspections to be performed on completion of endurance tests shall be those scheduled in Table 6. Unless otherwise stated, the measurements shall be performed at $T_{amb} = +22 \pm 3$ °C.
- 4.8.4 Conditions for Operating Life Tests (Part of Endurance Testing)
Not applicable.
- 4.8.5 Electrical Circuits for Operating Life Tests (Figure 5)
Not applicable.
- 4.8.6 Conditions for High Temperature Storage Test (Part of Endurance Testing)
The requirements for the high temperature storage test are specified in Section 9 of ESA/SCC Generic Specification No. 3401. The temperature to be applied shall be the maximum storage temperature specified in Table 1(b) of this specification.



TABLE 6 - MEASUREMENTS AND INSPECTIONS ON COMPLETION OF ENVIRONMENTAL AND ENDURANCE TESTS

NO.	ESA/SCC GENERIC SPEC. NO. 3401		MEASUREMENTS AND INSPECTIONS		SYMBOL	LIMITS		UNIT
	ENVIRONMENTAL AND ENDURANCE TESTS (1)	TEST METHOD AND CONDITIONS	IDENTIFICATION	CONDITIONS		MIN.	MAX.	
01	Seal Test	Para. 9.9	ESA/SCC 3401 Para. 9.9	-	-	Not applicable		-
02	Wiring	Para. 9.10 and Table 1(d) of this specification	Low Level Contact Resistance	Table 2 Item 4	Rcl	Table 2, Item 4		-
03	Vibration	Para. 9.11	Final Measurements Full Engagement Visual Examination		- -	- -	- -	- -
04	Shock or Bump	Para. 9.12	Full Engagement Visual Examination	- -	- -	- -	- -	- -
05	Climatic Sequence	Para. 9.13	Dry Heat Insulation Resistance Low Air Pressure Voltage Proof Leakage Current Damp Heat Insulation Resistance Final Measurements External Visual Inspection Insulation Resistance Voltage Proof Leakage Current	At High Temperature Table 2, Item 1 Figure 1 Immediately after test Table 2, Item 1 After 1-24 hrs Recovery ESA/SCC 3401 Para. 9.7 Table 2, Item 1 Table 2, Item 2	Ri I _L Ri - Ri I _L	1000 ESA/SCC 3401 Para. 9.13.5 100 ESA/SCC 3401 Para. 9.7 Table 2, Item 1 Table 2, Item 2	- - - -	MΩ - MΩ -
06	Plating Thickness	Para. 9.14	Thickness	-	-	Para 4.4.2 of this spec.		-
07	Joint Strength (N/A to solder contacts)	Para. 9.15	ESA/SCC 3401 Para. 9.15	-	-	Not applicable		-
08	Rapid Change of Temperature	Para. 9.16	Visual Examination Insulation Resistance Voltage Proof Leakage Current	- Table 2, Item 1 Table 2, Item 2	- Ri I _L	- Table 2, Item 1 Table 2, Item 2	- -	- -
09	Contact Retention (In Insert)	Para. 9.17 and Para. 4.3.4 of this spec.	Contact Displacement	Not applicable for male contacts	-	ESA/SCC 3401 Para. 9.17		-

NOTES

1. The tests in this Table refer to either Chart IV or V and shall be used as applicable.



TABLE 6 - MEASUREMENTS AND INSPECTIONS ON COMPLETION OF ENVIRONMENTAL AND ENDURANCE TESTS (CONTINUED)

NO.	ESA/SCC GENERIC SPEC. NO. 3401		MEASUREMENTS AND INSPECTIONS		SYMBOL	LIMITS		UNIT
	ENVIRONMENTAL AND ENDURANCE TESTS (1)	TEST METHOD AND CONDITIONS	IDENTIFICATION	CONDITIONS		MIN.	MAX.	
10	Endurance	Para. 9.18	Initial Measurements Mating/Unmating Forces Low Level Contact Resistance Mated Shell Conductivity Final Measurements Visual Examination Mating/Unmating Forces Low Level Contact Drift Resistance Mated Shell Conductivity Insulation Resistance Voltage Proof Leakage Current	Table 2, Item 4 Table 2, Item 3 - Table 2, Item 4 Table 2, Item 5 Table 2, Item 3 Table 2, Item 1 Table 2, Item 2	F Rcl Vd - F ΔRcl Vd Ri I _L	Para 4.3.5 of this spec. Record Values Not applicable - Para. 4.3.5 of this spec. - 3.0 Not applicable Table 2, Item 1 Table 2, Item 2	- mΩ	
11	Permanence of Marking	Para. 9.19	-	-	-	-	-	-
12	Mating/Unmating Forces	Para. 9.20	Force	-	F	Para 4.3.5 of this spec.		
13	High Temperature Storage	Para. 9.21	Initial Measurements Low Level Contact Resistance Mated Shell Conductivity Final Measurements Visual Examination Mating/Unmating Forces Low Level Contact Drift Resistance Rated Current Contact Resistance Mated Shell Conductivity Insulation Resistance Voltage Proof Leakage Current Contact Retention (In Insert)	Table 2, Item 4 - - Table 2, Item 4 Table 2, Item 5 Table 2, Item 3 Table 2, Item 1 Table 2, Item 2 Para. 4.3.4 of this spec.	Rcl Vd - F ΔRcl Rcr Vd Ri I _L	Record Values Not applicable - Para. 4.3.5 of this spec. - 3.0 Table 2, Item 5 Not applicable Table 2, Item 1 Table 2, Item 2 ESA/SCC 3401 Para. 9.17	- mΩ	
14	Corrosion	Para. 9.22	Visual Examination	-	-	-	-	-
15	Insert Retention (In Shell)	Para. 9.23 and Para. 4.3.6 of this spec.	Visual Examination	-	-	Not applicable		-
16	Jackscrew Retention	Para. 9.24 and Para. 4.3.7 of this spec.	Visual Examination	-	-	Not applicable		

NOTES

1. The tests in this Table refer to either Chart IV or V and shall be used as applicable.



TABLE 6 - MEASUREMENTS AND INSPECTIONS ON COMPLETION OF ENVIRONMENTAL AND ENDURANCE TESTS (CONTINUED)

NO.	ESA/SCC GENERIC SPEC. NO. 3401		MEASUREMENTS AND INSPECTIONS		SYMBOL	LIMITS		UNIT
	ENVIRONMENTAL AND ENDURANCE TESTS (1)	TEST METHOD AND CONDITIONS	IDENTIFICATION	CONDITIONS		MIN.	MAX.	
17	High Temperature Measurements	Para. 9.25	Insulation Resistance	Table 2, Item 1	Ri	5000	-	MΩ
18	Overload Test	Para. 9.26	Internal Temperature	-	T	-	+ 100	°C
			Rated Current Contact Resistance	Table 2, Item 5	Rcr	Table 2, Item 5		
			Mated Shell Conductivity	Table 2, Item 3	Vd	Not applicable		
			Insulation Resistance	Table 2, Item 1	Ri	Table 2, Item 1		
			Voltage Proof Leakage Current	Table 2, Item 2	I _L	Table 2, Item 2		
19	Maintenance Ageing	Para. 9.27 and Paras. 4.2.4 and 4.2.5 of this spec.	Visual Examination Contact Retention (In Insert)	- -	- -	Not applicable Not applicable		
20	Engagement/Separation Forces	Para. 9.28 and Para. 4.3.9 of this spec.	Force	-	F	Para. 4.3.9 of this spec.		
21	Oversize Pin Exclusion	Para. 9.29 and Para. 4.3.10 of this spec.	-	-	-	Not applicable		
22	Probe Damage	Para. 9.30 and Para. 4.3.11 of this spec.	Contact Separation Force	-	-	Not applicable		
23	Solderability	Para. 9.31 and Para. 4.3.12 of this spec.	-	-	-	Not applicable		

NOTES

1. The tests in this Table refer to either Chart IV or V and shall be used as applicable.