



europaean space agency
agence spatiale européenne

Pages 1 to 22

**CONNECTORS, MINIATURE, ELECTRICAL,
CIRCULAR, BAYONET COUPLING,
HERMETIC RECEPTACLE,
BASED ON TYPE DBC 5*H**

ESA/SCC DETAIL SPECIFICATION NO. 3401/043



**space components
coordination group**

Issue/Rev.	Date	Approved by	
		SCCG Chairman	ESA Director General or his Deputy
Issue 1	February 1989		
Revision 'A'	October 1989		



ESA/SCC Detail Specification
No. 3401/043

Rev. 'A'

PAGE 2

ISSUE 1

DOCUMENTATION CHANGE NOTICE

Rev. Letter	Rev. Date	Reference	CHANGE Item	Approved DCR No.
'A'	Oct '89	Cover Page		None
		DCN		None
		P 6. Table 1(b)	: Temperature ranges, "Maximum Rating", amended to 175°C	22740
			: Item Numbers corrected to read "1, 2, 3,4"	None
		P 8. Figure 2	: Dimensions added which define the contacts	22740
		P 9. Figure 2	: Second Note added	22740
		P 10. Figure 2	: Second Note added	22740
		P 14. Para. 4.2.4	: Paragraph rewritten	22740
P20. Para.4.8.6	: Second sentence, temperature amended	22740		



TABLE OF CONTENTS

	<u>Page</u>
1. <u>GENERAL</u>	5
1.1 Scope	5
1.2 Range of Components	5
1.3 Maximum Ratings	5
1.4 Parameter Derating Information	5
1.5 Physical Dimensions	5
2. <u>APPLICABLE DOCUMENTS</u>	7
3. <u>TERMS, DEFINITIONS, ABBREVIATIONS, SYMBOLS AND UNITS</u>	7
4. <u>REQUIREMENTS</u>	7
4.1 General	7
4.2 Deviations from Generic Specification	14
4.2.1 Deviations from Special In-process Controls	14
4.2.2 Deviations from Final Production Tests (Chart II)	14
4.2.3 Deviations from Burn-in Tests (Chart III)	14
4.2.4 Deviations from Qualification, Environmental and Endurance Tests (Chart IV)	14
4.2.5 Deviations from Lot Acceptance Tests (Chart V)	14
4.3 Mechanical Requirements	15
4.3.1 Dimension Check	15
4.3.2 Weight	15
4.3.3 Engagement and Separation Forces	15
4.3.4 Contact Retention	15
4.3.5 Insert Retention	15
4.3.6 Pull Test	15
4.4 Materials and Finishes	16
4.4.1 Shells	16
4.4.2 Inserts	16
4.4.3 Contacts	16
4.4.4 Gaskets	16
4.5 Marking	16
4.5.1 General	16
4.5.2 The SCC Component Number	16
4.5.3 Characteristics	17
4.5.4 Traceability Information	19
4.5.5 Marking of Small Components	19
4.6 Electrical Measurements	19
4.6.1 Electrical Measurements at Room Temperature	19
4.6.2 Electrical Measurements at High and Low Temperatures	19
4.6.3 Circuit for Electrical Measurements	19
4.7 Burn-in and Electrical Measurements	19
4.8 Environmental and Endurance Tests	20
4.8.1 Measurements and Inspections on Completion of Environmental Tests	20
4.8.2 Measurements and Inspections at Intermediate Points during Endurance Tests	20
4.8.3 Measurements and Inspections on Completion of Endurance Tests	20
4.8.4 Conditions for Operating Life Test (Part of Endurance Testing)	20
4.8.5 Electrical Circuits for Operating Life Test	20
4.8.6 Conditions for High Temperature Storage Test (Part of Endurance Testing)	20



TABLES

1(a)	Range of Components	6
1(b)	Maximum Ratings	6
2	Electrical Measurements at Room Temperature	19
3	Not applicable	
4	Not applicable	
5	Not applicable	
6	Measurements and Inspections on Completion of Environmental and Endurance Tests	21

FIGURES

1	Parameter Derating Information	7
2	Physical Dimensions - Receptables and Plugs	8
2(a)	Physical Dimensions - Standard Contact Arrangements	11
2(b)	Physical Dimensions - Special Contact Arrangements	12
2(c)	Physical Dimensions - Insert Clocking Positions	13

APPENDICES (Applicable to specific Manufacturers only)

None.

**1. GENERAL****1.1 SCOPE**

This specification details the ratings, physical and electrical characteristics, test and inspection data for Connectors, Miniature, Electrical, Circular, Bayonet-Coupling, Hermetic Receptacle, Based on Type DBC 5*H.

It shall be read in conjunction with:

- ESA/SCC Generic Specification No. 3401, "Connectors, Electrical, Circular and Rectangular",
- ESA/SCC Detail Specification No. 3401/007, "Connectors, Miniature, Electrical, Circular, Bayonet-Coupling, Crimp-type, Removable Contacts, Based on Type DFE",

the requirements of which are supplemented herein.

1.2 RANGE OF COMPONENTS

The different sizes of the basic type connectors specified herein, which are also covered by this specification, together with their mechanical characteristics, are given in Table 1(a).

1.3 MAXIMUM RATINGS

The maximum ratings, which shall not be exceeded at any time during use or storage, applicable to the connector savers specified herein, are scheduled in Table 1(b).

1.4 PARAMETER DERATING INFORMATION

The applicable derating information for the connectors specified herein is shown in Figure 1.

1.5 PHYSICAL DIMENSIONS

The physical dimensions of the connectors specified herein are shown in Figure 2.

**TABLE 1(a) - RANGE OF COMPONENTS**

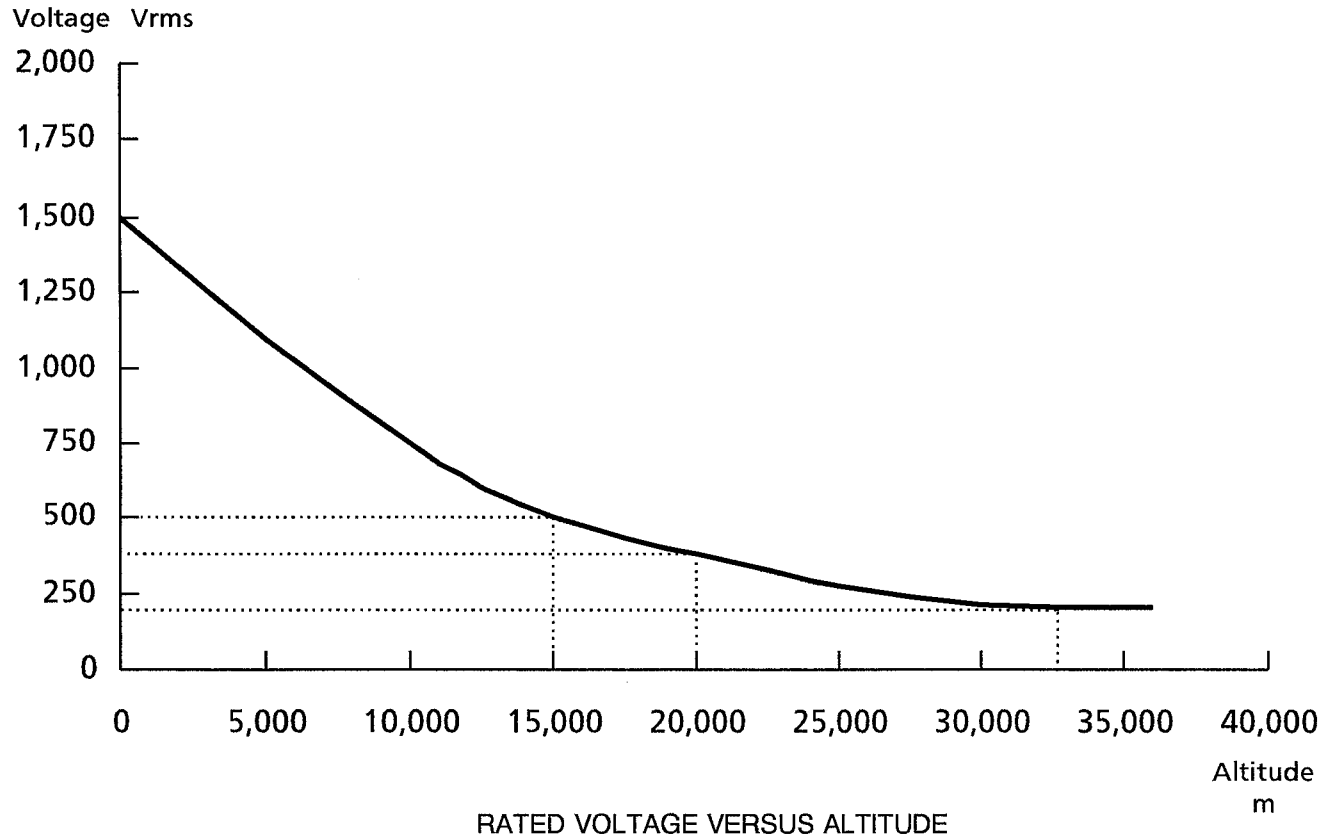
SHELL SIZE	MAX. WEIGHT (g)
08	10
10	15
12	22
14	27
16	35
18	42
20	55
22	70
24	90

TABLE 1(b) - MAXIMUM RATINGS

NO	CHARACTERISTICS	SYMBOL	MAXIMUM RATING		UNIT
			MIN	MAX	
1	Rated Voltage	U_R	1500	-	Vrms (1)
2	Operating Temperature Range	T_{op}	-55	+175	°C
3	Storage Temperature Range	T_{stg}	-65	+175	°C
4	Rated Current	I_R			
	Contacts #20		-	5	A
	Contacts #16		-	10	A
	Contacts #12		-	17	A

NOTES 1. See Figure 1.

FIGURE 1 - PARAMETER DERATING INFORMATION



2. APPLICABLE DOCUMENTS

The following documents form part of this specification and shall be read in conjunction with it:-

- (a) ESA/SCC Generic Specification No. 3401, "Connectors, Electrical, Circular and Rectangular".
- (b) ESA/SCC Detail Specification No. 3401/007, "Connectors, Miniature, Electrical, Circular, Bayonet-Coupling, Crimp-type, Removable Contacts, Based on Type DFE".
- (c) MIL-STD-202, Test Methods for Electronic and Electrical Component Parts.

3. TERMS, DEFINITIONS, ABBREVIATIONS, SYMBOLS AND UNITS

For the purpose of this specification, the terms, definitions, abbreviations, symbols and units specified in ESA/SCC Basic Specification No. 21300 shall apply.

4. REQUIREMENTS

4.1 GENERAL

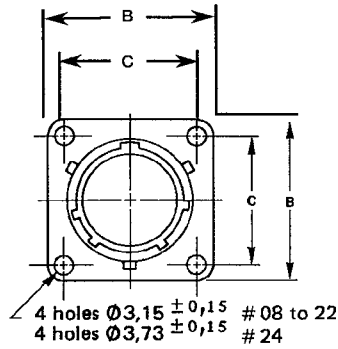
The complete requirements for procurement of the connectors specified herein are stated in this specification and ESA/SCC Generic Specification No. 3401. Deviations from the Generic Specification applicable to this specification only, are listed in Para 4.2.

Deviations from the applicable Generic Specification and this Detail Specification, formally agreed with specific Manufacturers on the basis that the alternative requirements are equivalent to the ESA/SCC requirements and do not affect the components' reliability, are listed in the Appendices attached to this specification.

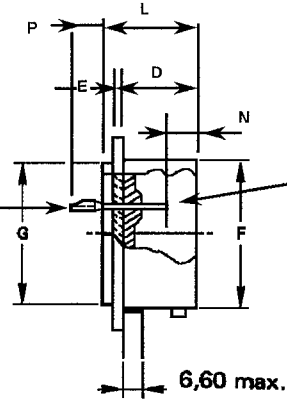


**FIGURE 2 - PHYSICAL DIMENSIONS
RECEPTACLES AND PLUGS**

Shell type 50: Square flange receptacle



Contact Size	Contact Solder Pot	
	Internal \varnothing	External \varnothing
#20	1.3 - 1.5	1.8-2
#16	1.8 - 2	2.56-2.76
#12	2.9 - 3.1	3.66-3.86



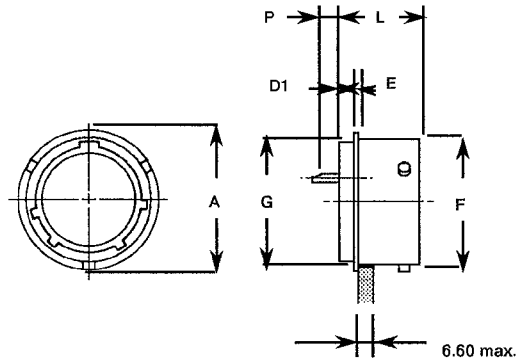
Contact Size	Contact Engagement End
#20	$\varnothing 0.99 - 1.04$
#16	$\varnothing 1.56 - 1.61$
#12	$\varnothing 2.36 - 2.41$

SHELL SIZE	B	C ± 0.1	D ± 0.15	E max	F max	G max	L max	P max		N ± 0.15
								#20	# 16-12	
08	21.00	15.08	14.95	1.60	12.03	14.30	20.35	4.55	6.30	1.99
10	24.20	18.26	14.95	1.60	15.01	17.10	20.35	4.55	6.30	1.99
12	26.55	20.62	14.95	1.60	19.07	19.90	20.35	4.55	6.30	1.99
14	28.95	23.02	14.95	1.60	22.24	23.05	20.35	4.55	6.30	1.99
16	31.30	24.58	14.95	1.60	25.42	26.25	20.35	4.55	6.30	1.99
18	33.70	26.98	14.95	1.60	28.60	29.40	20.35	4.55	6.30	1.99
20	36.85	29.36	16.55	2.40	31.77	31.80	21.95	4.55	6.30	3.57
22	39.95	31.76	16.55	2.40	34.94	34.95	22.75	3.70	5.50	3.57
24	43.15	34.92	16.55	2.40	38.12	38.15	22.75	3.70	5.50	3.57

NOTES 1. All dimensions are in millimetres.



Shell type 53: Solder flange receptacle

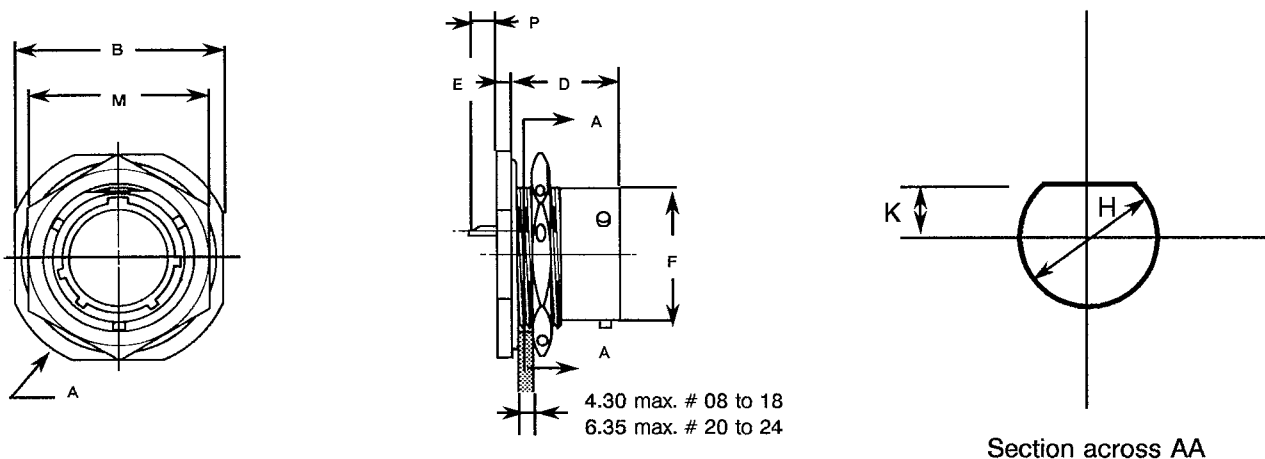


SHELL SIZE	A max	D1 max	E max	F max	G max	L max	P max	
							#20	# 16-12
08	16.15	4.00	0.90	12.03	14.30	20.35	4.55	6.30
10	19.30	4.00	0.90	15.01	17.10	20.35	4.55	6.30
12	21.70	4.00	0.90	19.07	19.90	20.35	4.55	6.30
14	24.90	4.00	0.90	22.24	23.05	20.35	4.55	6.30
16	28.05	4.00	0.90	25.42	26.25	20.35	4.55	6.30
18	31.20	4.00	0.90	28.60	29.40	20.35	4.55	6.30
20	33.60	4.00	0.90	31.77	31.80	21.95	4.55	6.30
22	36.80	4.80	0.90	34.94	34.95	22.75	3.70	5.50
24	40.00	4.80	0.90	38.12	38.15	22.75	3.70	5.50

NOTES

1. All dimensions are in millimetres.
2. For the Contact Solder Pot and Contact Engagement End dimensions, see page 8.

Shell type 54: Single hole mounting receptacle



SHELL SIZE	A max	B max	D ± 0.15	E max	F max	H max	K max	M max	P max	
									#20	# 16-12
08	27.35	24.20	17.78	2.85	12.03	14.30	13.50	19.20	3.40	5.20
10	30.55	27.35	17.78	2.85	15.01	17.50	16.65	22.37	3.40	5.20
12	35.30	32.15	17.78	2.85	19.07	22.25	20.80	27.12	3.40	5.20
14	38.50	35.30	17.78	2.85	22.24	25.45	23.95	30.30	3.40	5.20
16	41.65	38.50	17.78	2.85	25.42	28.60	27.10	33.47	3.40	5.20
18	44.80	41.65	17.78	2.85	28.60	31.80	20.25	36.67	3.40	5.20
20	49.60	46.40	19.43	3.70	31.77	34.95	33.45	39.82	2.55	2.55
22	52.75	49.60	19.43	3.70	34.94	38.15	36.60	43.02	2.55	2.55
24	55.95	52.75	20.17	3.70	38.12	41.30	39.80	46.17	2.55	2.55

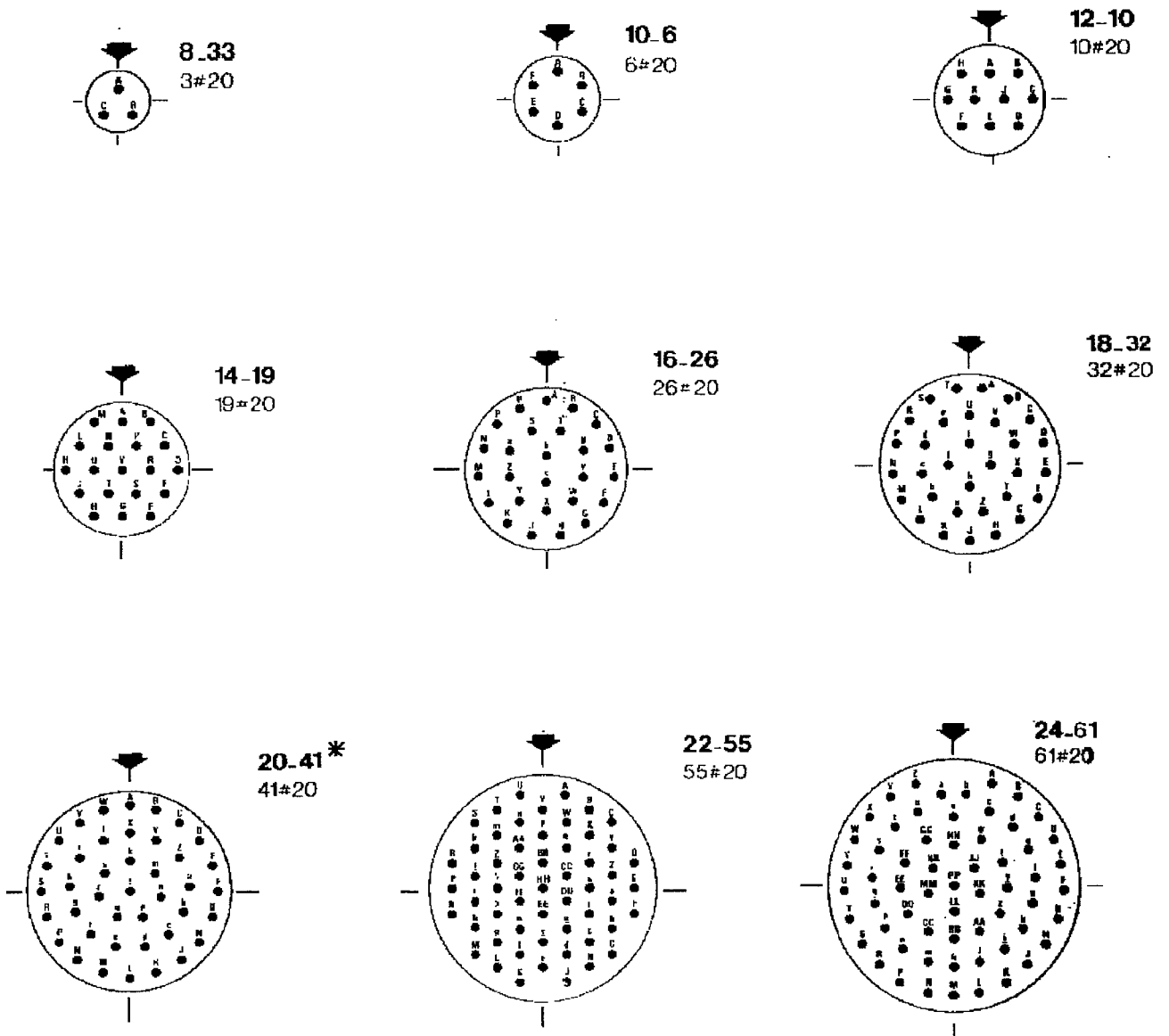
NOTES

1. All dimensions are in millimetres.
2. For the Contact Solder Pot and Contact Engagement End dimensions, see page 8.



**FIGURE 2(a) - PHYSICAL DIMENSIONS
STANDARD CONTACT ARRANGEMENTS - FRONT VIEW PIN INSERT**

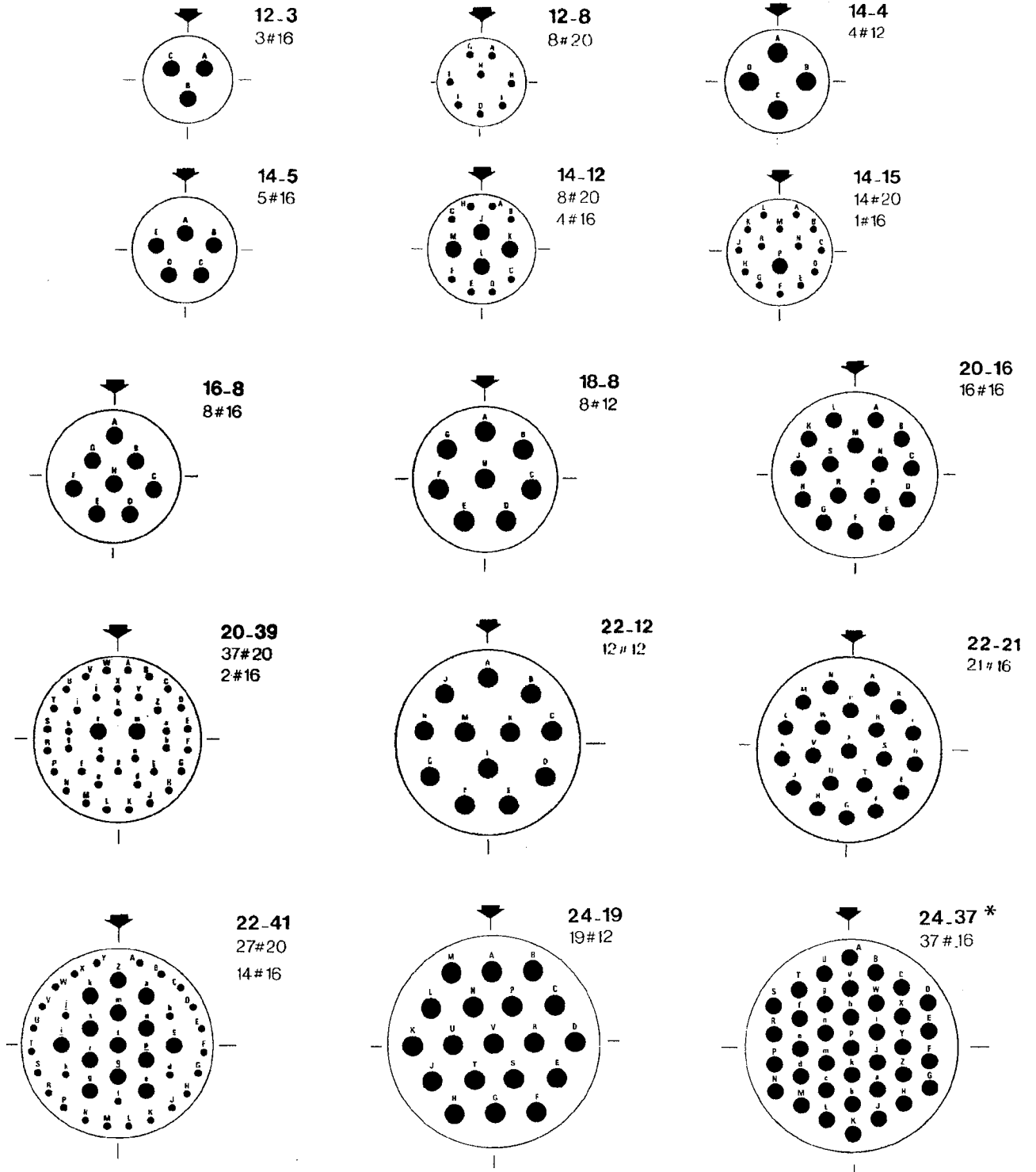
(See Paragraph 4.5 for definition of numbers)



Contact locations in conformity with the applicable MS drawing.

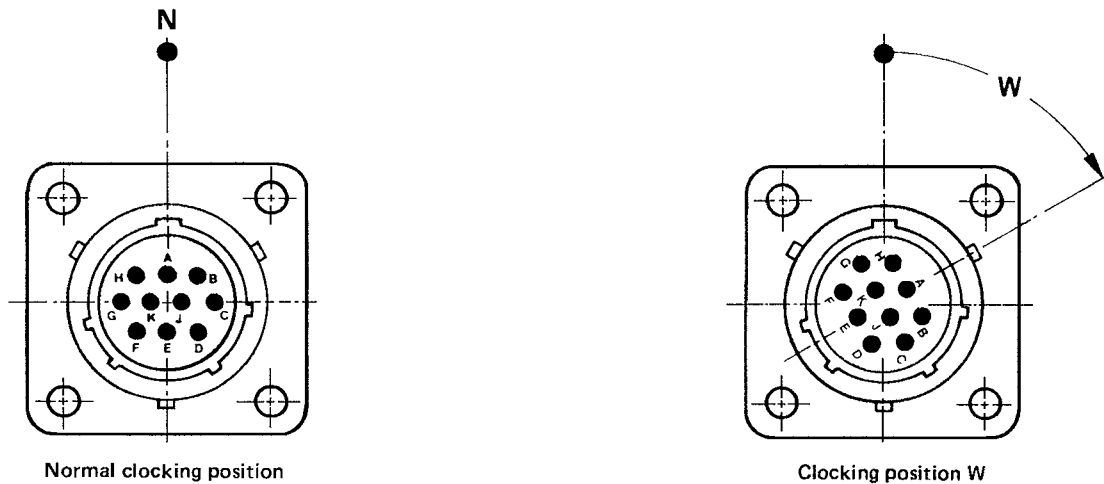


**FIGURE 2(b) - PHYSICAL DIMENSIONS
SPECIAL CONTACT ARRANGEMENTS - FRONT VIEW PIN INSERT**





**FIGURE 2(c) - PHYSICAL DIMENSIONS
INSERT CLOCKING POSITIONS**



The normal position is achieved when the vertical axis of the insert (Figures 2(a) and 2(b) is the same as the axis of the key in the shell (position N). Mating of two connectors with the same contact arrangement, standing side by side, can be made fool-proof by rotating one of the inserts within its shell. Rotation shall be clockwise for male inserts and anti-clockwise for female inserts. Determined rotations give clocking positions W, X and Y as specified hereunder.

CONTACT ARRANGEMENT	CLOCKING POSITIONS (°)		
	W	X	Y
08-33	90	-	-
10-6	90	-	-
12-3	-	-	180
12-8	90	112	203
12-10	60	155	270
14-4	-	-	-
14-5	40	92	184
14-12	43	90	-
14-15	17	110	155
14-19	30	165	315
16-8	54	152	180
16-26	60	105	275
18-8	-	-	-
18-32	85	138	222
20-16	238	318	333
20-39	63	144	252
20-41	45	126	225
22-12	-	-	-
22-21	16	135	175
22-41	39	135	264
22-55	30	142	226
24-19	30	165	315
24-37	25	50	75
24-61	90	180	270



4.2 DEVIATIONS FROM GENERIC SPECIFICATION

4.2.1 Deviations from Special In-process Controls

None.

4.2.2 Deviations from Final Production Tests (Chart II)

Para 9.3, "Intermateability": shall be performed with 3401/007 plugs.

Para 9.4, "Contact Retainer test": Not applicable.

Para 9.6, "Female Contact Capability": Not applicable.

Para 9.7, "Magnetism Level": Not applicable.

Add the following test: Hermeticity test

Each hermetic receptacle shall be submitted to an hermeticity test according to MIL-STD-202, Method 112, Condition "C", Procedure I. The leakage rate shall not exceed 1×10^{-6} atm cc/s He.

4.2.3 Deviations from Burn-in Tests (Chart III)

Not applicable.

4.2.4 Deviations from Qualification, Environmental and Endurance Tests (Chart IV)

For the purpose of these tests, where mated connectors are specified, the corresponding plug in the DFE series (3401/007) shall be used.

Add to the end of each subgroup an hermeticity test as specified in Para.4.2.2.

Para. 9.8, "Vibration": 20g, 10 - 2000Hz.

Para. 9.9, "Mechanical Shock": 100g, 11 milliseconds, $\frac{1}{2}$ sine wave.

Para. 9.13, "Thermal Shock": Temperature as specified in Table 1(b).

Para 9.16, "Vacuum Test": Not applicable.

Para 9.17, "Maintenance Ageing": Not applicable.

4.2.5 Deviations from Lot Acceptance Tests (Chart V)

The same deviations as listed in Para 4.2.4 above are applicable.



4.3 MECHANICAL REQUIREMENTS

4.3.1 Dimension Check

The dimensions of the connectors specified herein shall be verified in accordance with the requirements set out in Para 9.11 of ESA/SCC Generic Specification No. 3401 and shall conform to those shown in Figure 2 of this specification.

4.3.2 Weight

The maximum weight of the connectors specified herein shall be as specified in Table 1(a).

4.3.3 Engagement and Separation Forces

The torques applied for engagement and separation of the connectors shall conform to the values specified in Table 1(a) of ESA/SCC Detail Specification No. 3401/007.

4.3.4 Contact Retention

The contacts, chosen in the centre of the insert, shall be submitted to the force specified hereafter applied to their engagement end and the connector shall subsequently meet the hermeticity test requirements.

CONTACT SIZE AWG	PUSH FORCE DANmin.
20	9
16	11.5
12	11.5

4.3.5 Insert Retention

Connector inserts shall withstand a pressure of 70 Bars for 5 minutes and the connector shall subsequently meet the hermeticity test requirements.

4.3.6 Pull Test

The soldered wire of the applicable size shall be submitted to a pull test as specified in Para 9.29 of ESA/SCC Generic Specification No. 3401. The wire shall break before the solder.



4.4 MATERIALS AND FINISHES

The materials and finishes shall be as specified herein. Where a definite material is not specified, a material which will enable the connectors specified herein to meet the performance requirements of this specification shall be used. Acceptance or approval of any constituent material does not guarantee acceptance of the finished product.

4.4.1 Shell

The shell shall be made of steel and nickel plated (minimum thickness 25 μ m).

4.4.2 Insert

The insert shall be made of glass.

4.4.3 Contacts

The contacts shall be made of nickel-iron with nickel underplate and gold finish of 1.27 μ m minimum thickness.

4.4.4 Gasket

The gasket shall be made of silicone.

4.5 MARKING

4.5.1 General

The marking of all components delivered to this specification shall be in accordance with the requirements of ESA/SCC Basic Specification No. 21700 and the following subparagraphs. Each component shall be marked in respect of:-

- (a) The SCC Component Number.
- (b) Characteristics.
- (b) Traceability information.

4.5.2 The SCC Component Number

The SCC component number shall be constituted and marked as follows:-

Detail Specification Number _____ 340104301B
Type variant (*) _____
Testing level _____

- (*) Marking of the type variant number is mandatory. No further reference to type variants is made in this specification.

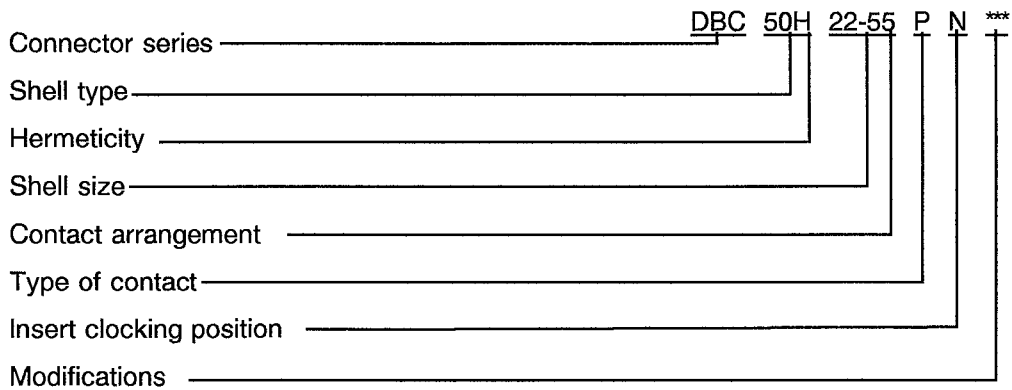


4.5.3 Characteristics

The characteristics to be marked in the following order of precedence are:-

- (a) Connector series.
- (b) Shell type.
- (c) Hermeticity.
- (d) Shell size.
- (e) Contact arrangement.
- (f) Type of contact.
- (g) Insert clocking position.
- (h) Modifications.

The information shall be constituted and marked as follows:-



4.5.3.1. Connector Series

This connector series shall be designated by the letters DBC.

4.5.3.2 Shell Type

The shell type shall be indicated by the following numbers:

CODE NO	SHELL TYPE
50	Square flange receptacle
53	Solder flange receptacle
54	Single hole mounting receptacle

4.5.3.3 Hermeticity

Hermetic receptacles are designated by the letter "H".

4.5.3.4 Shell Sizes and Contact Arrangements

Shell sizes and contact arrangements are closely related together and shall be indicated by the following codes:

CODE SHELL-SIZE - CONTACT ARRANGEMENT	NUMBER OF CONTACTS
08-33 10-6 12-3 12-8 12-10 14-4 14-5 14-12 14-15 14-19 16-8 16-26 18-8 18-32 20-16 20-39 20-41 22-12 22-21 22-41 22-55 24-19 24-37 24-61	<p style="text-align: center;">Number of contacts and contact sizes are as shown in Figures 2(a) & 2(b)</p>

4.5.3.5. Type of Contact

The contact type shall be indicated by the following code letter:-

CODE LETTER	CONTACT TYPE
P	Male

4.5.3.6 Insert Clocking Position

Insert clocking positions are as shown in Figure 2(c) and shall be designated by the following code letters: N, W, X, Y.

4.5.3.7 Modification Codes

Modification codes shall be expressed in numbers, letters or both. When there is no modification of the standard product, no code shall appear.

- Plating codes: Nickel plating shall be identified by code A499.



4.5.4 Traceability Information

Traceability information shall be marked in accordance with the requirements of ESA/SCC Basic Specification No. 21700.

4.5.5 Marking of Small Components

Where it is considered that a component is too small to accommodate the marking as specified above, as much as space permits shall be marked. The order of precedence shall be as specified in subparagraph 4.5.1. The marking information in full shall accompany each component in its primary package.

4.6 ELECTRICAL MEASUREMENTS

4.6.1 Electrical Measurements at Room Temperature

The parameters to be measured in respect of electrical characteristics are scheduled in Table 2. Unless otherwise specified these measurements shall be performed at $T_{amb} = +22 \pm 3 \text{ }^\circ\text{C}$.

4.6.2 Electrical Measurements at High and Low Temperatures (Table 3)

Not applicable.

4.6.3 Circuit for Electrical Measurements (Figure 4)

Not applicable.

4.7 Burn-in and Electrical Measurements (Tables 4 and 5)



Not applicable.

TABLE 2 - ELECTRICAL MEASUREMENTS AT ROOM TEMPERATURE

NO	CHARACTERISTICS	SYMBOL	SPEC. AND/OR TEST METHOD	TEST CONDITION	LIMITS		UNIT
					MIN	MAX	
1	Insulation Resistance	Ri	ESA/SCC No. 3401 Para 9.1	Para 9.1	5000	-	mΩ
2	Voltage Proof	Vp	ESA/SCC No. 3401 Para 9.2	Para 9.2	1500	-	Vrms
3	Contact Resistance Low Level	Rc	ESA/SCC No. 3401 Para 9.28	Para 9.28.2 #20	-	28	mΩ
				#16	-	21	mΩ
				#12	-	14	mΩ
4	Contact Resistance Rated Current	Rc	ESA/SCC No. 3401 Para 9.28	Para 9.28.2 #20 5A	-	15	mΩ
				#16 10A	-	10	mΩ
				#12 17A	-	6	mΩ

TABLES 3, 4 AND 5

Not applicable.

		<p style="text-align: center;">ESA/SCC Detail Specification No. 3401/043</p>	<p style="text-align: center;">Rev. 'A'</p>	<p>PAGE 20 ISSUE 1</p>
---	---	--	---	----------------------------

4.8 ENVIRONMENTAL AND ENDURANCE TESTS

4.8.1 Measurements and Inspections on Completion of Environmental Tests

The parameters to be measured on completion of environmental testing shall be those specified in Table 6.

Unless otherwise specified, these measurements shall be performed at $T_{amb} = +22 \pm 3 \text{ }^\circ\text{C}$.

4.8.2 Measurements and Inspections at Intermediate Points during Endurance Tests.

Not applicable.

4.8.3 Measurements and Inspections on Completion of Endurance Tests

The parameters to be measured on completion of endurance tests shall be those specified in Table 6. Unless otherwise specified, these measurements shall be performed at $T_{amb} = +22 \pm 3 \text{ }^\circ\text{C}$.

4.8.4 Conditions for Operating Life Test (Part of Endurance Testing)

Not applicable.

4.8.5 Electrical Circuits for Operating Life Test

Not applicable.

4.8.6 Conditions for High Temperature Storage Test (Part of Endurance Testing)

The requirements for the high temperature storage test are specified in Section 9 of ESA/SCC Generic Specification No. 3401. The conditions for high temperature storage testing shall be $T_{amb} = +175(+0, -3) \text{ }^\circ\text{C}$.



TABLE 6 - MEASUREMENTS AND INSPECTIONS ON COMPLETION OF ENVIRONMENTAL AND ENDURANCE TESTS

No.	ESA/SCC GEN.SPEC.NO. 3401		MEASUREMENTS AND INSPECTIONS		SYMBOL	LIMITS		UNIT
	ENVIRONMENTAL AND ENDURANCE TESTS (1)	TEST METHOD AND CONDITIONS	IDENTIFICATION	CONDITIONS		MIN	MAX	
01	Vibration	Para 9.8	Full Engagement Visual Examination	-	-	-	-	-
02	Mechanical Shock	Para 9.9	Full Engagement Visual Examination	-	-	-	-	-
03	Moisture Resistance	Para 9.10	Insulation Resistance: Immediately after Test After 24 Hrs Recovery Voltage Proof External Visual Inspection	Table 2 Item 1 Table 2 Item 2 Gen 3401 Para 9.5	Ri Ri Vp	500 Table 2 Table 2	- - -	mΩ - -
04	Voltage Proof Altitude	Para 9.12 33000m	Voltage Proof	Table 2 Item 2	Vp	See Figure 1		-
05	Thermal Shock	Para 9.13	Voltage Proof Visual Examination	Table 2 Item 2 -	Vp	Table 2 - -		- -
06	Contact Retention in Insert	Para 9.14	Force Hermeticity	Para 4.3.4 Para 4.2.2	- -	Para 4.3.4 Para 4.2.2		
07	Endurance	Para 9.15 Engage/Separ Speed 5mm/s Max Frequency 8 Cycles/min	Engage/Separation Forces Contact Resistance Drift Contact #20 Contact #16 Contact #12 Insulation Resistance Voltage Proof Extern. Visual Inspection	Para 4.3.3. Table 2 Item 1 Table 2 Item 2 Gen 3401 Para 9.5	ΔRc ΔRc ΔRc Ri Vp	3401/007 - 4 - 3 - 2 Table 2 Table 2 - -		mΩ mΩ mΩ
08	Vacuum Test	Para 9.16	Not applicable					
09	Maintenance Ageing	Para 9.17	Not applicable					
10	Engagement/Separation Forces	Para 9.18	Force	Para 4.3.3	-	3401/007		-

NOTE: (1) The tests in this Table refer to either Chart IV or V and shall be used as applicable.

TABLE 6 - MEASUREMENTS AND INSPECTIONS ON COMPLETION OF ENVIRONMENTAL AND ENDURANCE TESTS

No.	ESA/SCC GEN.SPEC.NO. 3401		MEASUREMENTS AND INSPECTIONS		SYMBOL	LIMITS		UNIT
	ENVIRONMENTAL AND ENDURANCE TESTS (1)	TEST METHOD AND CONDITIONS	IDENTIFICATION	CONDITIONS		MIN	MAX	
11	High Temperature Storage	Para 9.19	Contact Resistance Drift Contact #20 Contact #16 Contact #12 Engagement/Separation Forces Final Insulation Resistance Extern. Visual Inspection	Para 4.3.3 Table 2 Item 1 Gen 3401 Para 9.5	ΔR_c ΔR_c ΔR_c - Ri	- - - 3401/007 Table 2 - -	m Ω m Ω m Ω - - - -	
12	Insert Retention in Shell	Para 9.20	Pressure Hermeticity	Para 4.3.5 Para 4.3.2	- -	Para 4.3.5 Para 4.3.2	- -	
13	Intermateability	Para 9.3	Engagement/Separation	-	-	- -	-	
14	External Visual Inspect.	Para 9.5	External Visual Inspection	Gen 3401 Para9.5	-	- -	-	
15	Hermeticity	Para 4.2.2 of this spec.	Hermeticity	Para 4.2.2	-	Para 4.2.2	-	
16	Gold Plate Thickness	Para 9.22	Gold Plate Thickness	-	-	Para 4.4.3	-	
17	Solderability	Para 9.27	Visual Examination	-	-	- -	-	
18	Contact Resistance	Para 9.28	Contact Resistance	Low Level Table 2 Item 3 Rated Lev Table 2 Item 4	Rc Rc	Table 2 Table 2	- -	
19	Pull Test	Para 9.29	Force	Para 4.3.6	-	Para 4.3.6	-	

NOTE: (1) The tests in this Table refer to either Chart IV or V and shall be used as applicable.